

**REPAIR PARTS MANUAL**  
**MODEL NO. 277362**  
**Lawn Tractor**



# HOW TO USE THIS MANUAL

This manual is designed to provide the customer with a means to identify the parts on his/her tractor when ordering repair parts. The illustrations may or may not represent the actual assemblies; therefore, it is not recommended to use this manual as a guide to assemble or disassemble the tractor. Some hardware and parts are drawn larger in order to more readily identify them.

Each tractor has its own model number.

The model number for your tractor can be found on the fender under the seat.

When ordering parts, always give the following information:

- Product - "Tractor"
- Model Number - "277362"
- Part Number
- Part Description

## TABLE OF CONTENTS

<b>SCHEMATIC .....</b>	<b>3</b>
<b>ELECTRICAL .....</b>	<b>4-5</b>
<b>CHASSIS.....</b>	<b>6-7</b>
<b>DRIVE.....</b>	<b>8-9</b>
<b>STEERING .....</b>	<b>10-11</b>
<b>SEAT .....</b>	<b>12</b>
<b>DECALS.....</b>	<b>13</b>
<b>ENGINE.....</b>	<b>14-15</b>
<b>MOWER LIFT.....</b>	<b>16-17</b>
<b>MOWER DECK .....</b>	<b>18-19</b>
<b>TRANSAXLE.....</b>	<b>20-21</b>
<b>ENGINE BREAKDOWN.....</b>	<b>22-27</b>
<b>WARRANTY .....</b>	<b>28</b>

# TRACTOR- -MODEL NO. 917. 277362

## SCHEMATIC

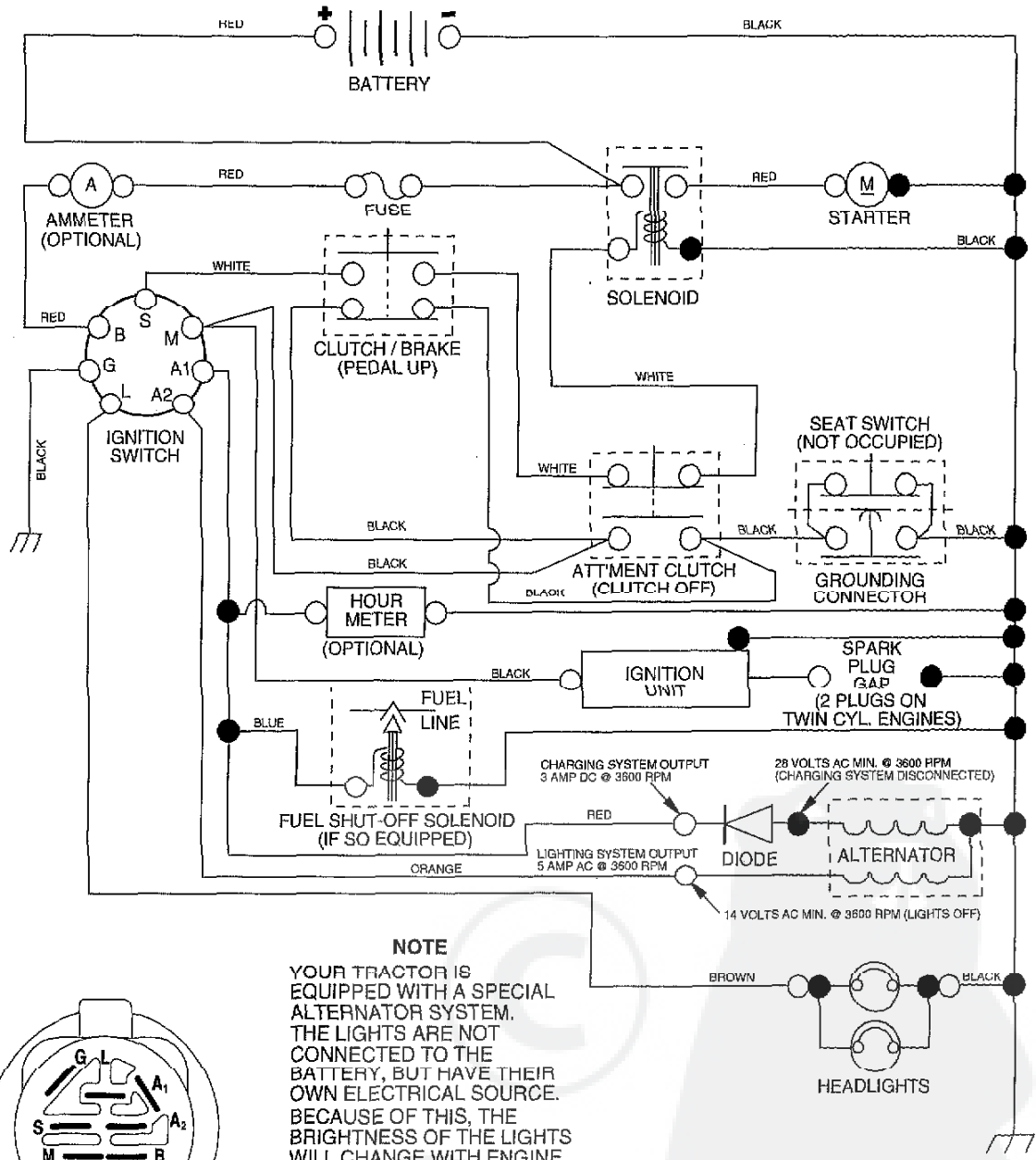

### NOTE

YOUR TRACTOR IS EQUIPPED WITH A SPECIAL ALTERNATOR SYSTEM. THE LIGHTS ARE NOT CONNECTED TO THE BATTERY, BUT HAVE THEIR OWN ELECTRICAL SOURCE. BECAUSE OF THIS, THE BRIGHTNESS OF THE LIGHTS WILL CHANGE WITH ENGINE SPEED. AT IDLE THE LIGHTS WILL DIM. AS THE ENGINE IS SPEEDED UP, THE LIGHTS WILL BECOME THEIR BRIGHTEST.

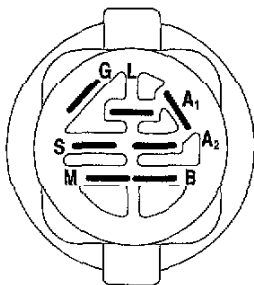

IGNITION SWITCH

POSITION	CIRCUIT	"MAKE"
OFF	M+G+A1	NONE
HUN/LIGHT	B+A1	A2+L
RUN	B+A1	NONE
START	B+S+A1	NONE

### WIRING INSULATED CLIPS

NOTE: IF WIRING INSULATED CLIPS WERE REMOVED FOR SERVICING OF UNIT, THEY SHOULD BE REPLACED TO PROPERLY SECURE YOUR WIRING.

02363

NON-REMOVABLE CONNECTIONS

REMOVABLE CONNECTIONS

# REPAIR PARTS

TRACTOR- -MODEL NO. 917.277362

## ELECTRICAL

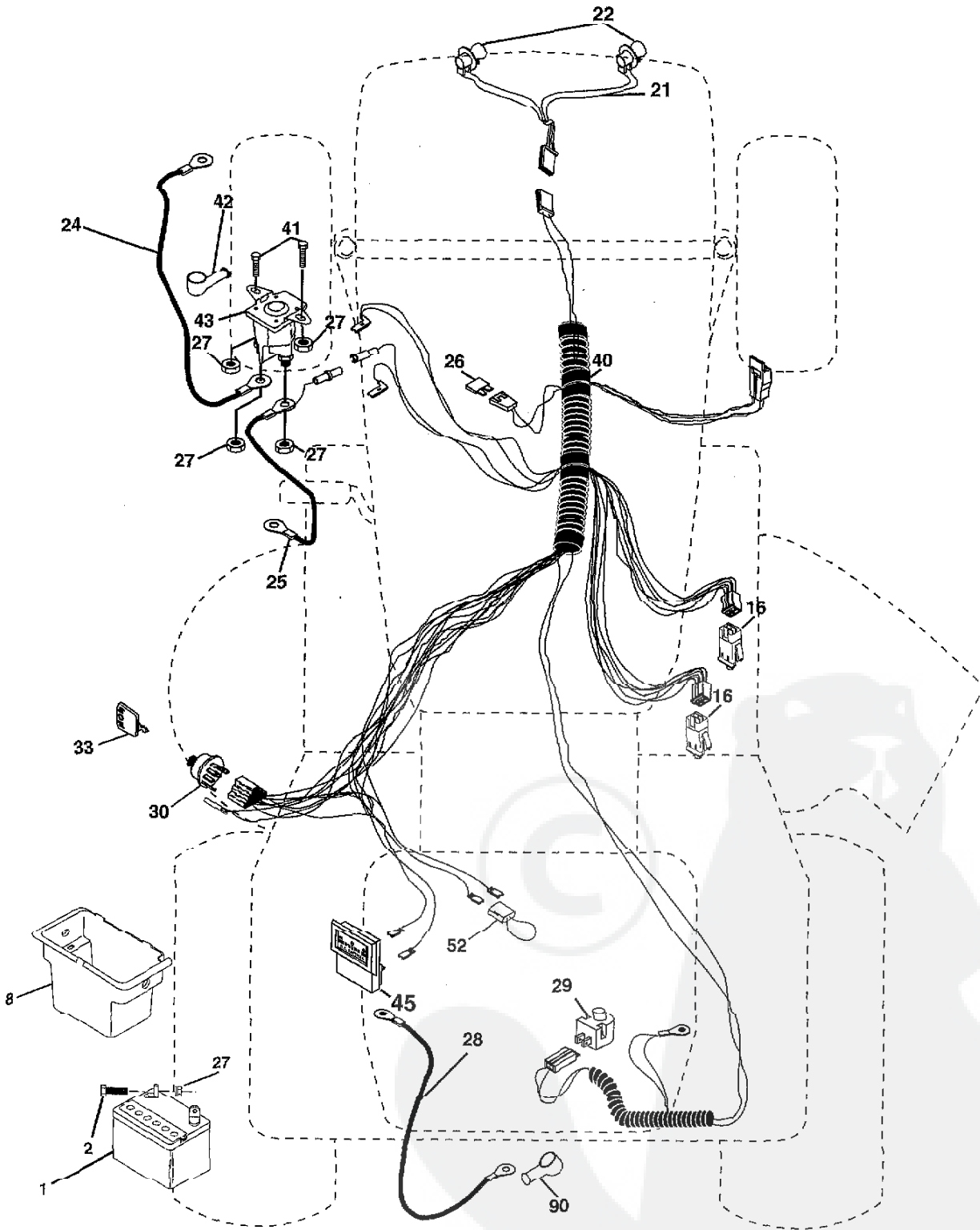

# REPAIR PARTS

TRACTOR- -MODEL NO. 917. 277362

## ELECTRICAL

KEY NO.	PART NO.	DESCRIPTION
1	163465	Battery
2	74760412	Bolt Hex Hd 1/4-20 unc x 3/4
8	176689	Box Battery
16	176138	Switch, Interlock
21	183759	Harness Asm Light W/4152j
22	4152J	Bulb Light #1156
24	4799J	Cable Battery 6 Ga. 11" red
25	146147	Cable Battery 6 Ga. w/16 wire red
26	175158	Fuse
27	73510400	Nut Keps Hex 1/4-20 unc
28	4207J	Cable Ground 6 Ga. 12" black
29	121305X	Switch Plunger Normal NC Gray
30	175566	Switch Ign
33	140403	Key Ign
40	179720	Harness Ign
41	71110408	Bolt Blk. Fin Hex 1/4-20 unc x 1/2
42	131563	Cover Terminal Red
43	178861	Solenoid
45	121433X	Ammeter Rectangular
52	141940	Protection Wire Loop
90	180449	Cover Terminal

**NOTE:** All component dimensions give in U.S. inches  
1 inch = 25.4 mm

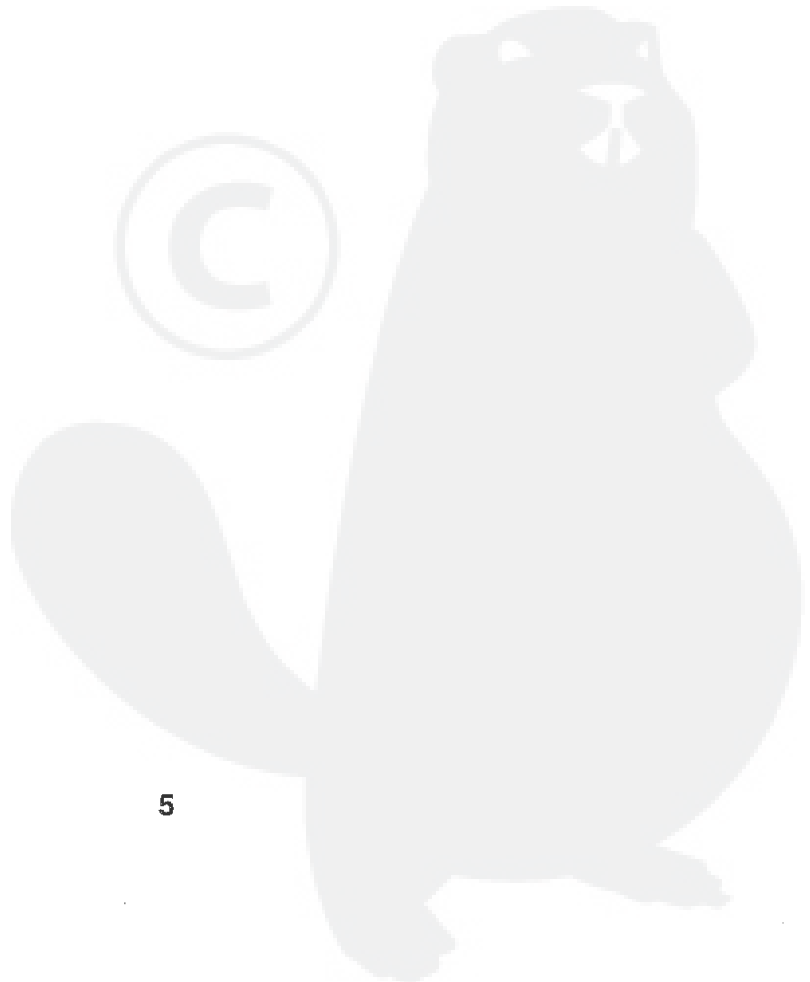
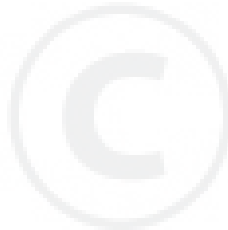

# REPAIR PARTS

TRACTOR- -MODEL NO. 917. 277362

## CHASSIS AND ENCLOSURES

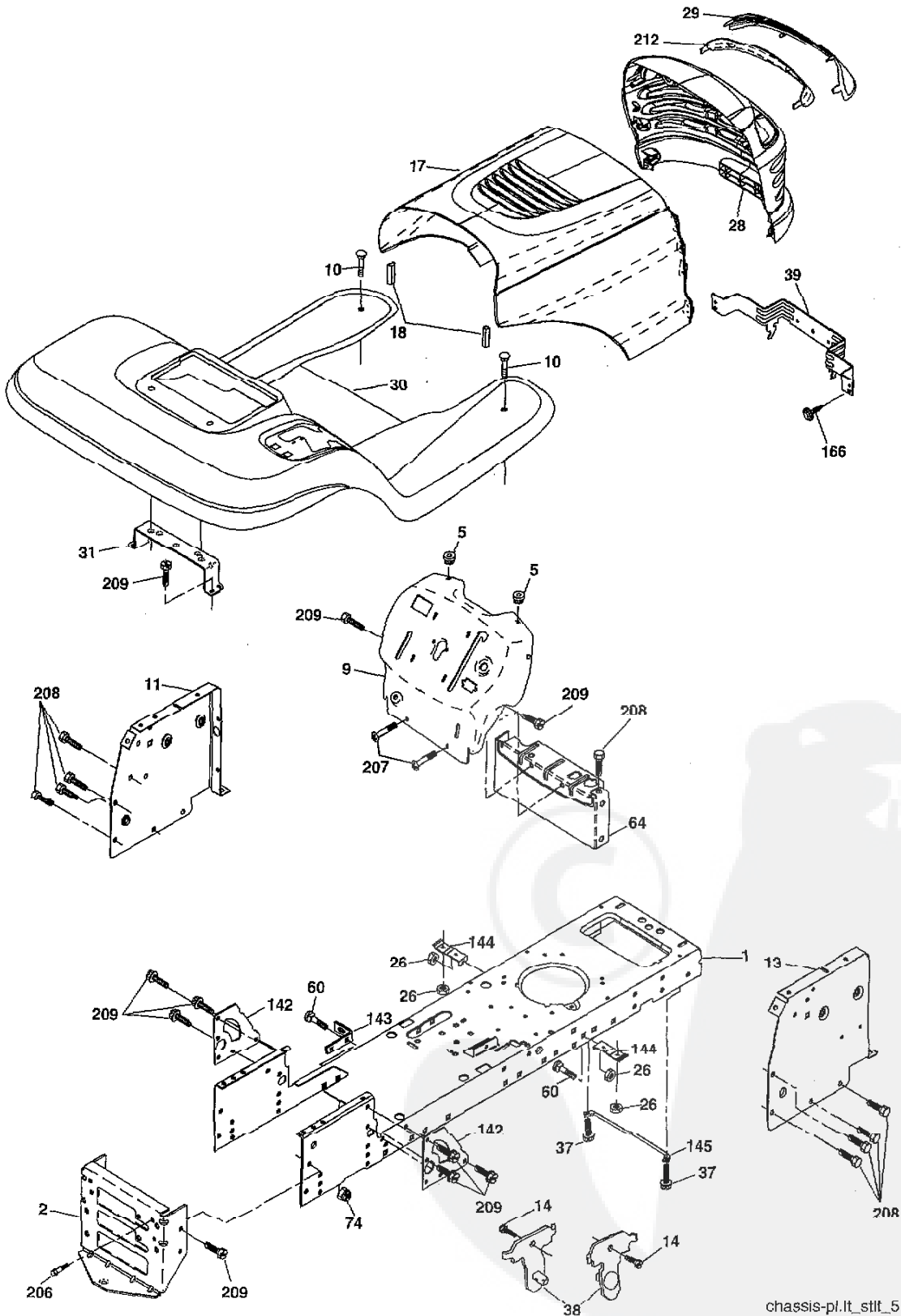

chassis-pl.it\_stlt\_51

# REPAIR PARTS

## TRACTOR- -MODEL NO. 917. 277362

### CHASSIS AND ENCLOSURES

KEY NO.	PART NO.	DESCRIPTION
1	174619	Chassis
2	176554	Drawbar
5	155272	Bumper Hood/Dash
9	187846X014	Dash
10	STD533710	Bolt, Carriage 3/8-16 x 3/4
11	174996	Panel, Dash, L.H.
13	172105X010	Panel, Dash, R.H.
14	17490608	Screw Thdrol 3/8-16 x 1/2
17	185682X558	Hood Assembly
18	184921	Bumper Hood
26	STD541437	Nut
28	190380	Grille/Lens Asm(Includes #'s 29 and 212)
29	174332X599	Lens Laser
30	188571X558	Fend/Ftrest
31	139976	Bracket, Fender Support
37	17490508	Screw Thdrol 5/16-18 x 1/2
38	175710	Pivot Bracket Assembly, Rear
39	174714	Bracket Pivot Laser Lt
60	72140606	Bolt Rdhd Sqnk 3/8-16 unc x 1
64	154798	Dash Lower STLT
74	STD541437	Nut Crownlock 3/8-16 unc
142	175702	Plate Reinforcement STLT
143	186689	Bracket Swaybar Chassis
144	175582	Bracket Pnt Footrest STLT
145	156524	Rod Pivot Chassis/Hood
166	171875	Screw Hwhd Hi-Lo #13-16 x 3/4
206	170165	Bolt Shoulder 5/16-18 TT
207	17670508	Screw Thdrol 5/16-18 x 1/2 Tytt
208	17670608	Screw Thdrol 3/8-16 x 1/2
209	17000612	Screw Hexwsh Thdr 3/8-16 x 3/4
212	175143	Insert Lens Reflective
--	5479J	Plug, Button

**NOTE:** All component dimensions given in U.S. inches  
1 inch = 25.4 mm

# REPAIR PARTS

## TRACTOR- -MODEL NO. 917. 277362

### DRIVE

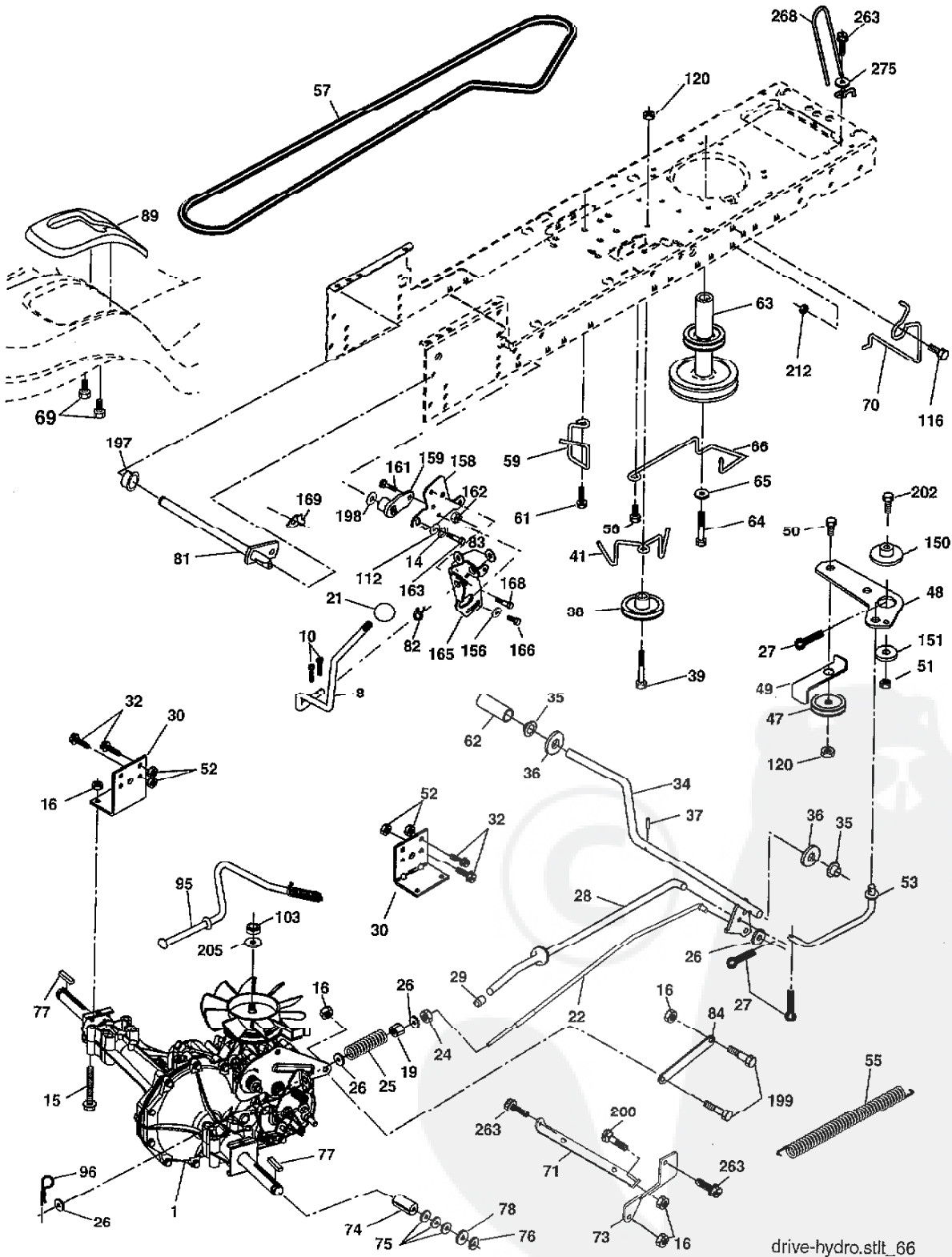



# REPAIR PARTS

## TRACTOR- -MODEL NO. 917. 277362

### DRIVE

KEY NO.	PART NO.	DESCRIPTION	KEY NO.	PART NO.	DESCRIPTION
1	-----	Transmission (See Breakdown) Hydro Gear Model 322-0510	70	180218	Guide, Belt, Mower Drive RH
8	165866	Rod, Shift	71	169183	Strap, Torque, Lh
10	STD561210	Pin, Cotter 1/8 x 1	73	169182	Strap, Torque, Rh
14	STD551125	Washer Lock 1/4	74	137057	Spacer, Axle
15	74490544	Bolt Hex FlgHd 5/16-18 Gr. 5	75	121749X	Washer 25/32 x 1-1/4 x 16 Ga.
16	73800500	Nut, Lock Hex w/Ins 5/16-18 unc	76	12000001	Ring, E
19	73800600	Nut Lock Hex w/Ins 3/8-16	77	123583X	Key, Square
21	130564	Knob	78	121748X	Washer 25/32 x 1-5/8 x 16 Ga.
22	169498	Rod, Brake	81	165596	Shaft Asm Cross
24	73350600	Nut	82	165711	Spring, Torsion
25	106888X	Spring, Rod, Brake	83	19171216	Washer 17/32 x 3/4 x 16 Ga.
26	19131316	Washer 13/32 x 13/16 x 16 Ga.	84	169843	Link Transaxle
27	STD561210	Pin, Cotter 1/8 x 3/4	89	188309X428	Console, Shift
28	175765	Rod, Parking Brake	95	170201	Control Asm Bypass Hydro
29	71673	Cap, Parking Brake	96	STD624003	Spring, Retainer 1"
30	1749/3	Bracket, Transmission	103	73940800	Nut Hex Jam Toplock 1/2-20 unf
32	74760512	Bolt Hex 5/16-18 unc x 3/4	116	72140608	Bolt Rdhd Sq Neck 3/8-16 x 1
34	175578	Shaft, Foot Pedal	120	73900600	Nut Lock Flg 3/8-16
35	120183X	Bearing, Nylon	150	175456	Spacer Retainer
36	19211616	Washer	151	19133210	Washer 13/32 x 2 x 10
37	1572H	Pin, Roll	156	166002	Washer 5/16 x 1.0 x 1.25
38	179114	Pulley, Composite	158	165589	Bracket Shift Mount
39	74760648	Bolt	159	183900	Hub Shift
41	175556	Keeper, Belt, Idler	161	72140406	Bolt Rdhd Sqnk 1/4-20 x 3/4 Gr. 5
47	127783	Pulley, Idler, V-Belt	162	73680400	Nut Crownlock 1/4-20 unc
48	154407	Bellcrank Clutch Grnd Drustl	163	74780416	Bolt Hex Fin 1/4-20 x 1
49	123205X	Retainer, Belt	165	165623	Bracket Pivot Lever
50	72110612	Bolt Carr. Sh 3/8-16 x 1-1/2 Gr. 5	166	17490510	Screw 5/16 x 18 x 5/8
51	STD541437	Nut	168	165492	Bolt Shoulder 5/16-18 x .561
52	STD541431	Nut Crownlock 5/16-18	169	165580	Plate Fastener Cross Shaft
53	105710X	Link, Clutch	197	169613	Nyliner Snap-In
55	105709X	Spring, Return, Clutch	198	169593	Washer Nyliner
56	17060620	Screw 3/8-16 x 1-1/4	199	169612	Bolt Shoulder 5/16-18 unc
57	140294	V-Belt, Drive	200	72140508	Bolt RdHd Sqnk 5/16-18 unc x 1
59	169691	Keeper, Belt, Center	202	72110614	Bolt Carr. Sh 3/8-16 x 1-3/4 Gr. 5
61	17120614	Screw 3/8-16 x .875	205	19171616	Washer 17/32 x 1 x 16 Ga.
62	8883R	Cover, Pedal	212	145212	Nut Hex Flange Lock
63	180219	Pulley, Engine	263	17000612	Screw 3/8-16 x 3/4
64	173937	Bolt Hex 7/16 x 4 Gr. 5	268	182402	Guard Muffler
65	10040700	Washer	271	17000612	Screw 3/8-16 x 3/4
66	154778	Keeper, Belt Engine Hydro	275	19131614	Washer 13/32 x 1 x 14 Ga.
69	142432	Screw Hex Wsh Hi-Lo 1/4-1/2 unc			

**NOTE:** All component dimensions given in U.S. inches  
1 inch = 25.4 mm

# REPAIR PARTS

TRACTOR- -MODEL NO. 917. 277362

## STEERING ASSEMBLY

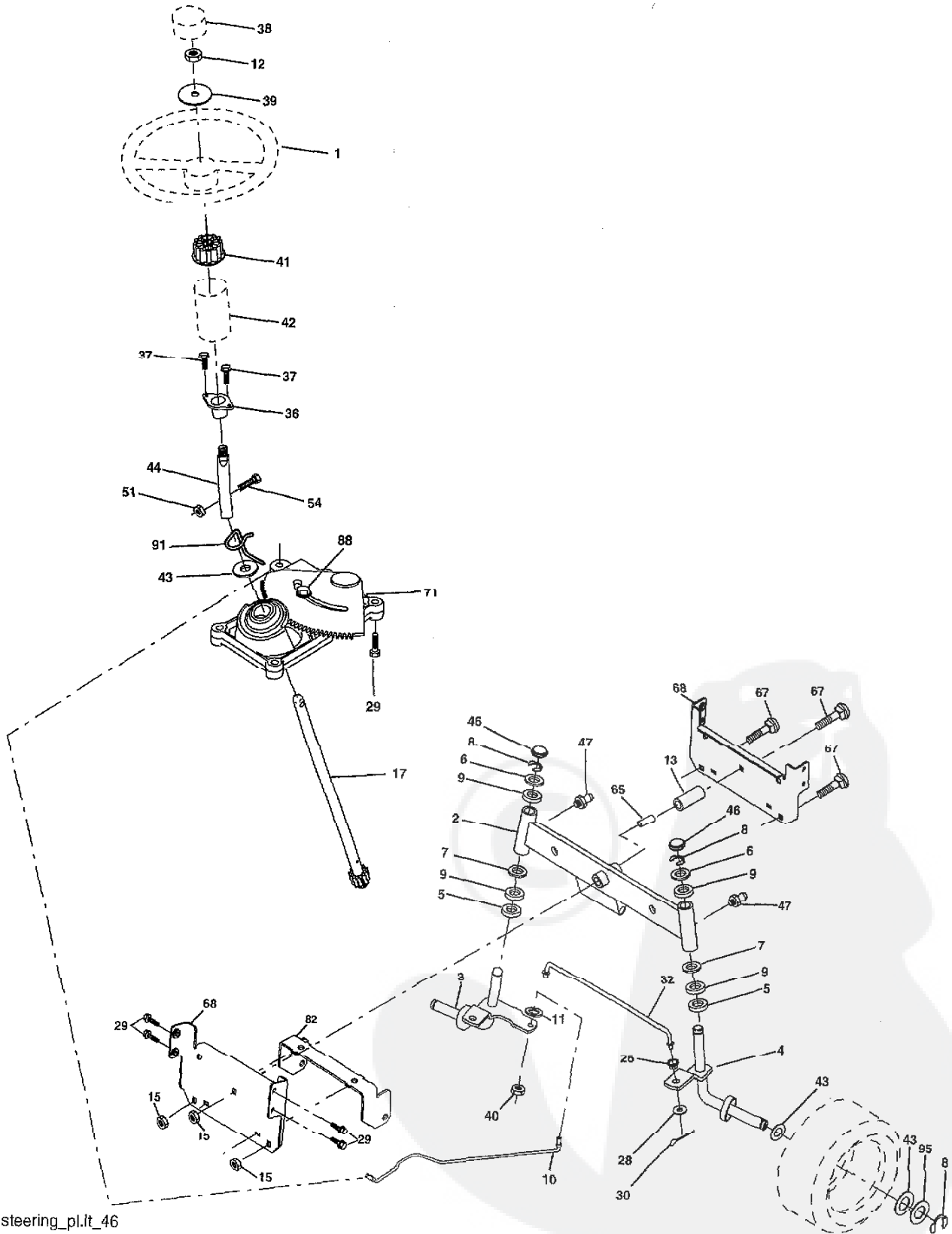

steering\_pl.it\_46

# REPAIR PARTS

## TRACTOR- -MODEL NO. 917. 277362

### STEERING ASSEMBLY

KEY NO.	PART NO.	DESCRIPTION
1	186780	Steering Wheel
2	175131	Axle Assembly
3	169840	Spindle Assembly, L.H.
4	169839	Spindle Assembly, R.H.
5	6266H	Bearing, Race, Thrust, Hardened
6	121746X	Washer 25/32 x 1-5/8 x 16 Ga.
7	19272016	Washer 27/32 x 1-1/4 x 16 Ga.
8	12000029	Ring, Klip
9	3366R	Bearing Col. Steering
10	175121	Draglink
11	STD551137	Washer, Lock
12	73940800	Nut Hex Jam Toplock 1/2-20 unf
13	136518	Spacer Bearing Axle Front
15	145212	Nut, Hex Flange Lock
17	180641	Shaft Assembly, Steering
26	126847X	Bushing, Link, Drag
28	19131416	Washer 13/32 x 7/8 x 16 Ga.
29	17000612	Screw 3/8-16 x 3/4
30	STD561210	Pin Cotter
32	130465	Rod, Tie
36	155099	Bushing, Steering
37	152927	Screw
38	186781	Insert, Steering Wheel
39	19183812	Washer 9/16 x 2-3/8 12 Ga.
40	73540600	Nut Crownlock 3/8-24
41	186737	Adaptor, Steering Wheel
42	145054X428	Boot, Steering Shaft
43	121749X	Washer 25/32 x 1-1/4 x 16 Ga.
44	180640	Extension Shaft Steering LR.LT
46	121232X	Cap, Spindle
51	73540400	Nut Crownlock 1/4-28
54	71130420	Bolt Hex 1/4-28 unf x 1-1/4 Gr. 8
65	160367	Spacer Brace Axle
67	72110618	Bolt RDHD Sqnk 3/8-16 x 2-1/4
68	169827	Axle, Brace
71	175146	Steering Asm.
82	169835	Bracket Susp. Chassis Front
88	175118	Bolt Shoulder 7/16-20 unc
91	175553	Clip Steering
95	188967	Washer Hardened

**NOTE:** All component dimensions given in U.S. inches  
1 inch = 25.4 mm

# REPAIR PARTS

TRACTOR- -MODEL NO. 917. 277362

## SEAT ASSEMBLY

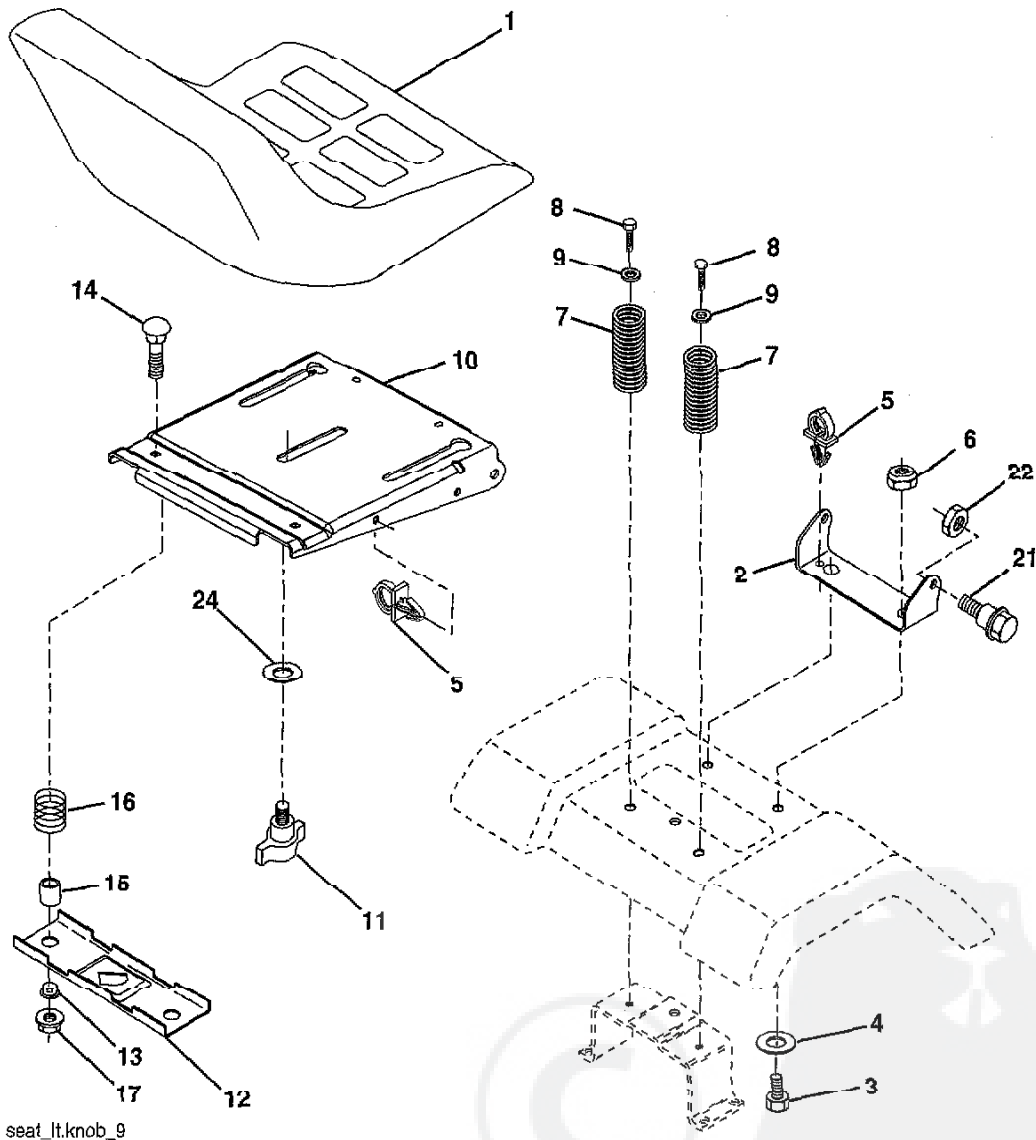

KEY NO.	PART NO.	DESCRIPTION
1	188716	Seat
2	180166	Bracket Pivot Seat
3	71110616	Bolt Fin Hex 3/8-16 unc x 1
4	19131610	Washer 13/32 x 3/4 x 10 Ga.
5	145006	Clip Push In Hinged
6	STD541437	Nut Hex Lock w/Ins 3/8-16 unc
7	124181X	Spring Seat Cprsn 2 250 Blk Zi
8	17000616	Screw 3/8-16 x 1
9	19131614	Washer 13/32 x 1 x 14 Ga.
10	180186	Pan Seat
11	166369	Knob Seat Adj Wingnut
12	121246X	Bracket Pnt Mounting Switch

KEY NO.	PART NO.	DESCRIPTION
13	121248X	Bushing Snap Blk Nyl 50 Id
14	72050412	Bolt Rdhd Sht Nk 1/4-20 x 1-1/2
15	134300	Spacer Split 28 x 96 Zinc
16	121250X	Spring Cprsn 1 27 Blk Pnt
17	123976X	Nut Lock 1/4 Lge Flg Gr. 5 Zinc
21	171852	Bolt Shoulder 5/16-18 unc-2A
22	STD541431	Nut Hex Lock w/Ins 5/16-18
24	19171912	Washer 17/32 x 1-3/16 x 12 Ga.

**NOTE:** All component dimensions given in U.S. inches  
1 inch = 25.4 mm

# REPAIR PARTS

## TRACTOR- -MODEL NO. 917. 277362

### DECALS

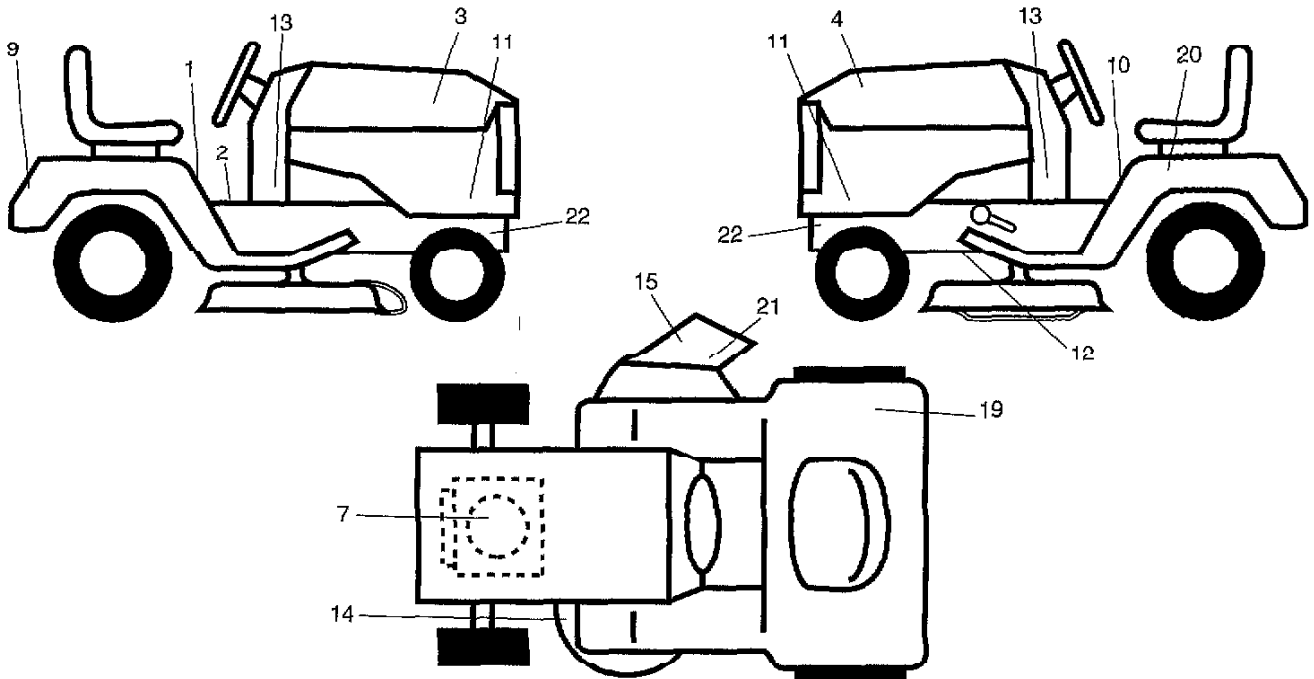

KEY NO.	PART NO.	DESCRIPTION
1	140837	Decal, Brake Parking Saddle
2	145498	Decal, Read Owners Manual
3	184728	Decal, Hood, R.H.
4	184729	Decal, Hood, L.H.
7	189224	Decal, HP Engine
9	184899	Decal, Fender, Craftsman
10	159737	Decal, Brake Clutch
11	184730	Decal, Panel Side
12	146046	Decal, V-Belt Drive Schematic
13	189276	Decal, Dash Panel
14	160396	Decal, V-Belt Schematic
15	179128	Decal, Deck B 42"

KEY NO.	PART NO.	DESCRIPTION
19	180432	Decal, DBA
20	145005	Decal Battery Dngr
21	182166	Decal, Cutfinger
22	159736	Decal, Hot Muffler
--	138311	Decal, Lift Handle
--	166960	Decal, By pass
--	162598	Decal, Draw Bar Load Limit
--	184310X428	Pad, Footrest LH STLT
--	184311X428	Pad, Footrest RH STLT
--	193294	Manual, Operator's (Euro)
--	193295	Manual, Operator's (Scand)
--	193296	Manual Parts

### WHEELS & TIRES

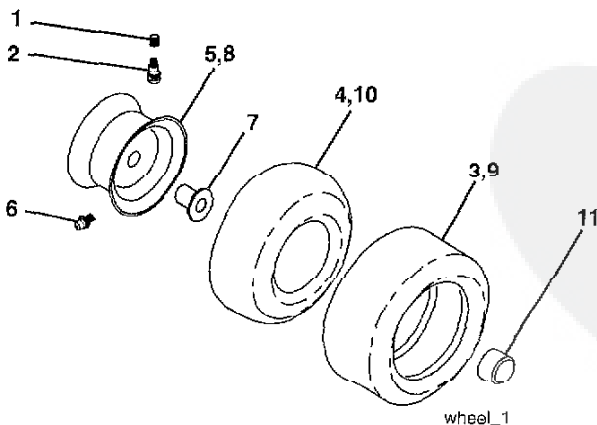

KEY NO.	PART NO.	DESCRIPTION
1	59192	Cap Valve Tire
2	65139	Stem Valve
3	106222X	Tire F Ts 15 x 6.0 - 6 Service
4	59904	Tube Inner Front #35060
5	106732X624	Rim Asm 6" front White Service
6	278H	Fitting Grease
7	9040H	Bearing Flange
8	106108X624	Rim Asm 8" rear White Service
9	124635X	Tire R Ts 18 x 8-5-8 C Service
10	7152J	Tube Rear 9 5 x 8 Service
11	104757X428	Cap Axle Bk 1 50 x 1 00
--	144334	Sealant, Tire (10 oz. tube)

**NOTE:** All component dimensions given in U.S. inches  
1 inch = 25.4 mm

# REPAIR PARTS

TRACTOR- -MODEL NO. 917. 277362

## ENGINE

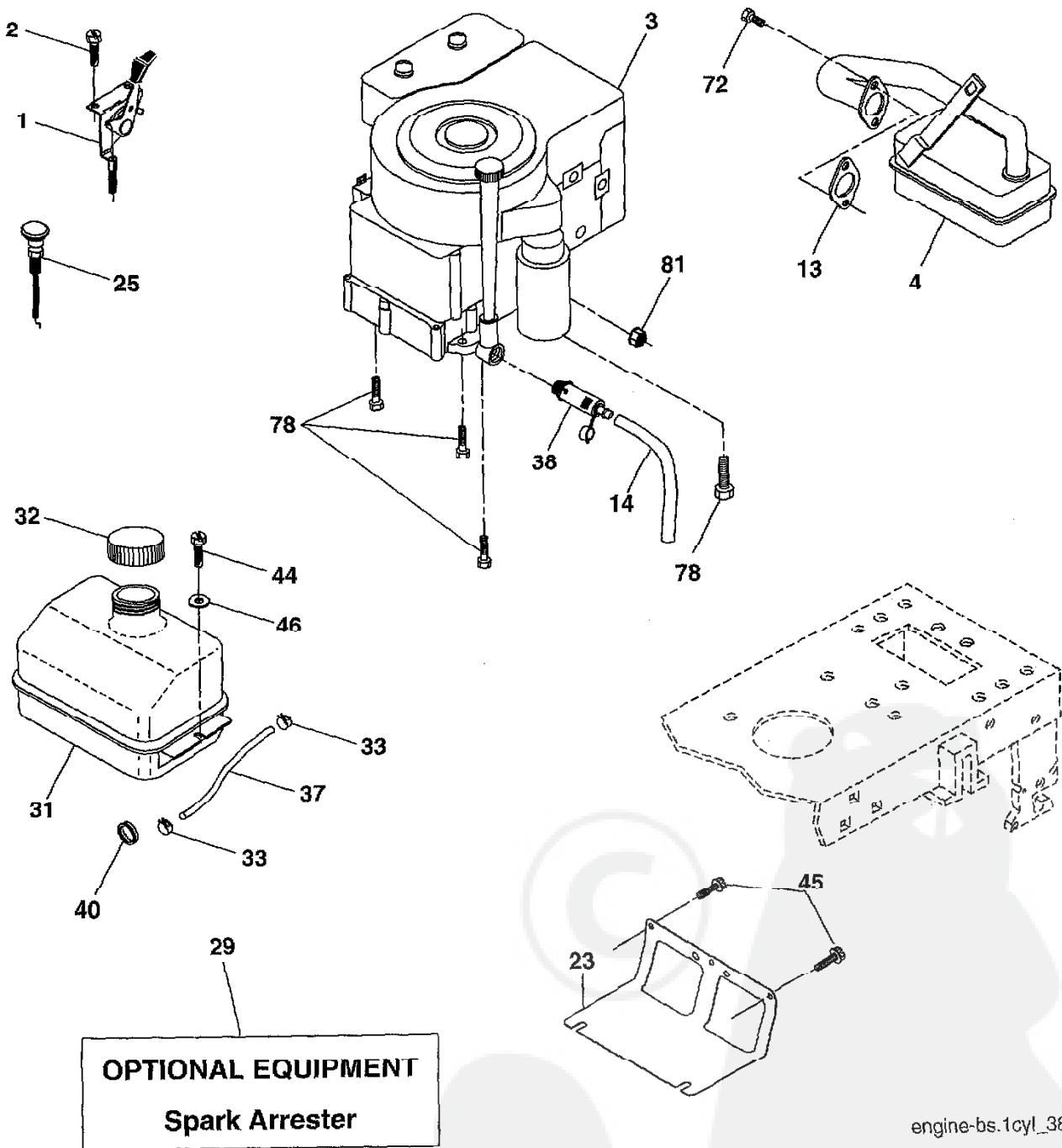

# REPAIR PARTS

TRACTOR- -MODEL NO. 917. 277362

## ENGINE

KEY NO.	PART NO.	DESCRIPTION
1	170545	Control, Throttle
2	17720408	Screw, Hex Head, Thread Cutting 1/4-20 x 1/2
3	-----	Engine, Briggs Model 31C707-0240-E1 (See Breakdown)
4	137352	Muffler
13	165291	Gasket
14	148456	Tube Drain Oil Easy
23	169837	Shield Brn/Dbr Guard
25	187770X428	Control Choke
29	137180	Arrestor, Spark
31	184900	Tank, Fuel
32	140527	Cap Assembly, Fuel Sears, Vented
33	123487X	Clamp, Hose
37	137040	Line, Fuel
38	181654	Plug Drain Oil Easy
40	124028X	Bushing, Snap, Fuel Line
44	17670412	Screw, Hex Washer Head, Thd., Roll. 1/4-20 x 3/4
45	17000612	Screw Hxwsh Thdr 3/8-16 x 3/4
46	19091416	Washer 9/32 x 7/8 x 18 Ga.
72	183906	Screw Socket Head 5/16-18 x 1
78	17060620	Screw 3/8-16 x 1-1/4
81	73510400	Nut Keps Hex 1/4-20

**NOTE:** All component dimensions given in U.S. inches  
1 inch = 25.4 mm

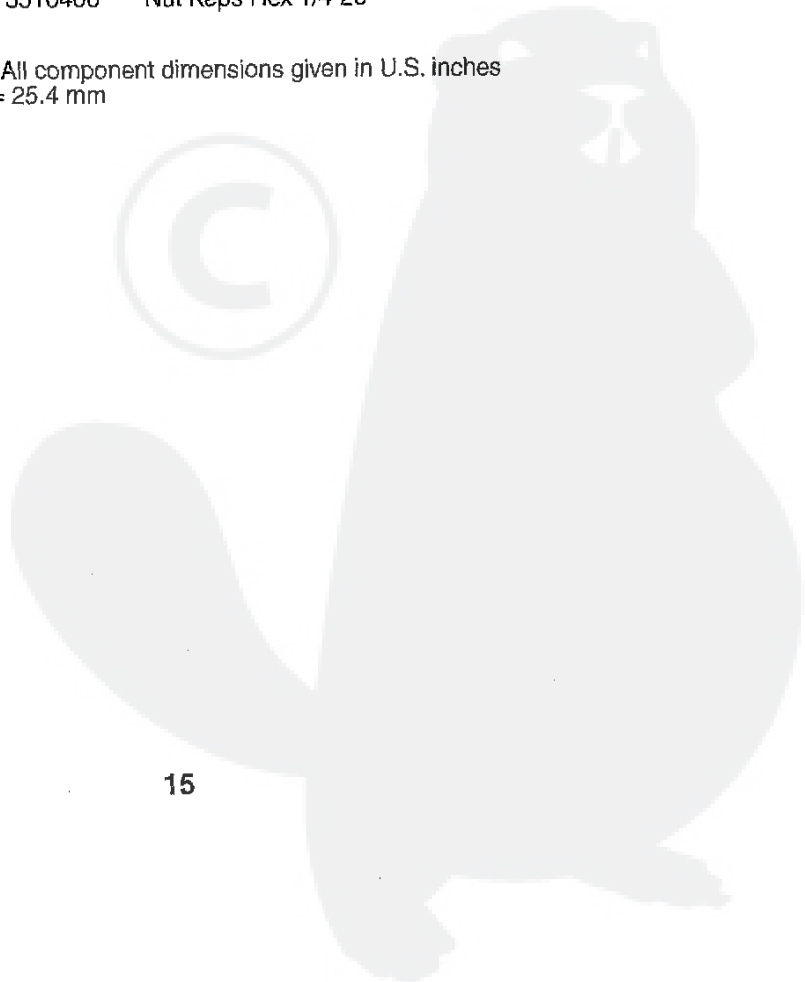
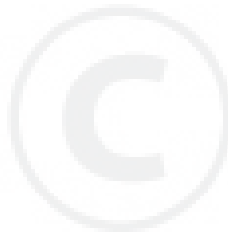

# REPAIR PARTS

TRACTOR- -MODEL NO. 917. 277362

## MOWER LIFT

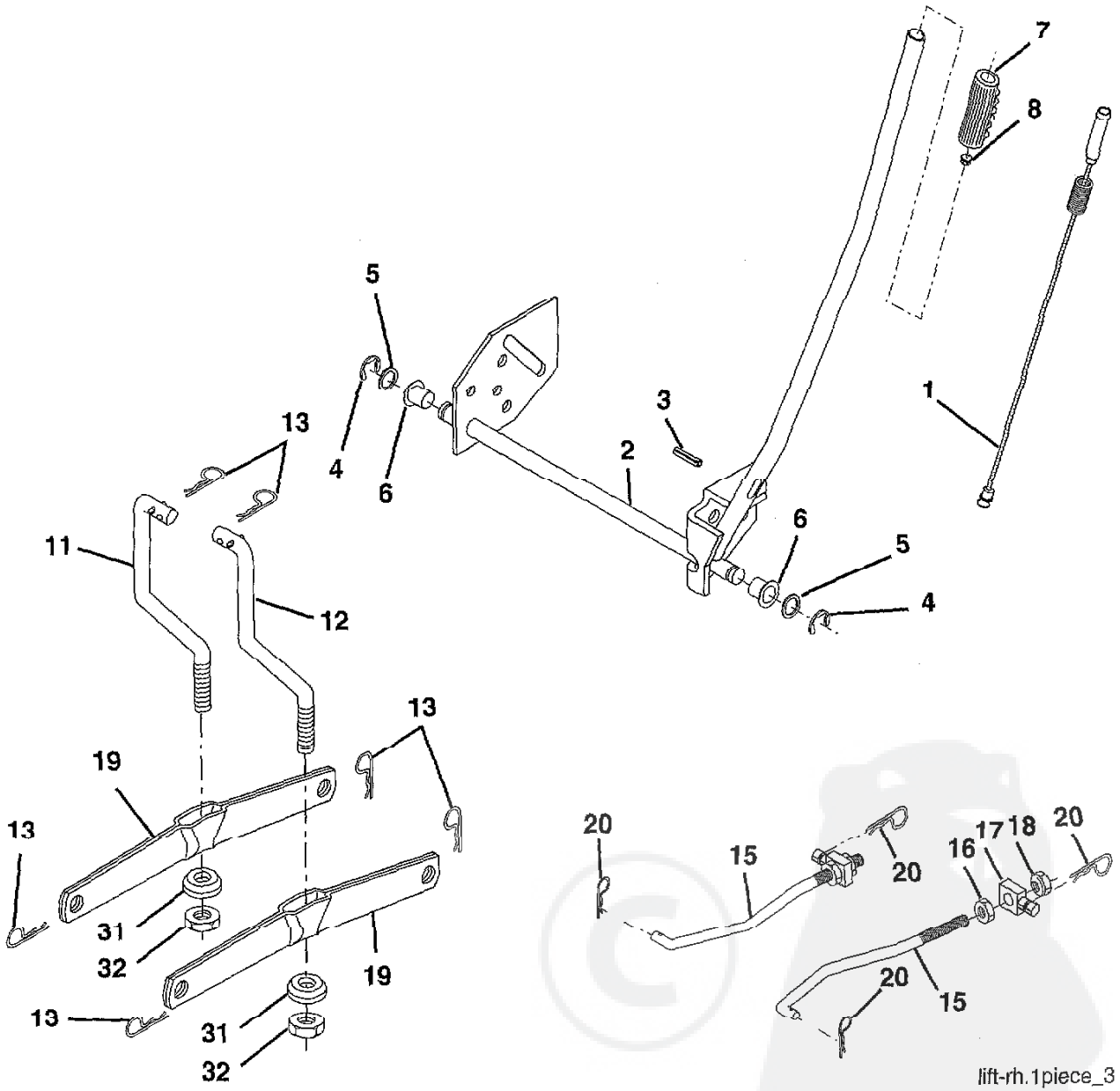



# REPAIR PARTS

TRACTOR- -MODEL NO. 917. 277362

MOWER LIFT

KEY NO.	PART NO.	DESCRIPTION
1	159460	Washer Asm Inner Spring W/Plunger
2	159471	Shaft Asm. Lift
3	105767X	Pin Groove
4	12000002	E Ring #5133-62
5	19211621	Washer 21/32 x 1 x 21 Ga.
6	120183X	Bearing Nylon
7	125631X	Grip Handle Fluted
8	122365X	Button Plunger Read
11	139865	Link Asm Lift L.H.
12	139866	Link Asm Lift R.H.
13	STD624008	Retainer Spring
15	173288	Link Front
16	73350800	Nut Jam Hex 1/2-13 unc
17	175689	Trunnion Blk Zinc
18	73800800	Nut Lock w/Wsh 1/2-13 unc
19	139868	Arm Suspension Mower
20	163552	Retainer Spring
31	169865	Bearing, Pvt. Lift
32	73540600	Nut Crownlock 3/8-24

**NOTE:** All component dimensions given in U.S. inches  
1 inch = 25.4 mm

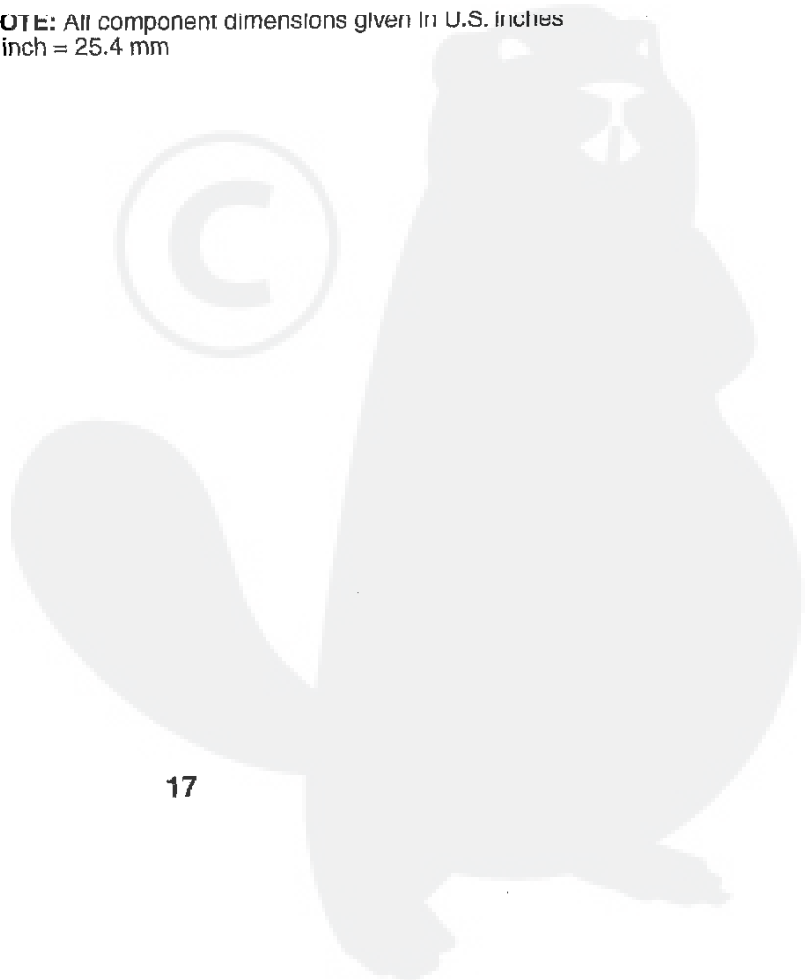
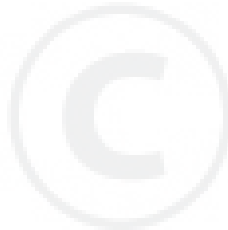



# REPAIR PARTS

## TRACTOR- -MODEL NO. 917. 277362

### MOWER

KEY NO.	PART NO.	DESCRIPTION	KEY NO.	PART NO.	DESCRIPTION
1	165892	Mower Deck Assembly, 42"	56	165723	Spacer, Retainer
2	STD533107	Bolt	59	141043	Guard, IUV Idler
3	138017	Bracket Assembly, Sway Bar, Front	67	184939	Knob Custom Oval
4	165460	Bracket Sway Bar 38/42" Deck	68	180215	V-Belt
5	STD624008	Retainer Spring	92	STD541437	Nut
6	178024	Bar Sway Deck	101	136420	Mulcher Cover
8	850857	Bolt, Hex 3/8-24 x 1.25 Gr. 8	102	71081010	Screw
9	STD551137	Washer, Lock	103	19061216	Washer #10
10	140296	Washer, Hardened	104	STD551110	Washer, Lock
11	134149	Blade,	105	160793	Latch Assembly, Bagger
13	137645	Shaft Assembly, Mandrel, Vented	106	2029J	Nut, Weld
14	128774	Housing, Mandrel, Vented	129	19131312	Washer 13/32 x 13/16 x 12 Ga.
15	110485X	Bearing, Ball, Mandrel	130	STD523710	Bolt, Fin Hex 3/8-16 unc x 1 Gr. 5
16	174493	Stripper, Vented Mower Deck	131	STD533710	Bolt, Rdhd Sqkn 3/8-16 unc x1
18	72140505	Bolt, Carriage 5/16-18 x 5/8	142	165890	Arm Spring Brake Mower
19	132827	Bolt, Shoulder	143	157109	Bracket Arm Idler 42"
20	159770	Baffle, Vortex	144	158634	Keeper Belt 42" Clutch Cable
21	STD541431	Nut Crownlock 5/16-18 unc	145	165888	Pulley Idler Flat
23	177563	Bracket, Deflector	146	171977	Bolt Carriage Idler
24	105304X	Cap, Sleeve	147	179748	Spring Extension
25	123713X	Spring, Torsion, Deflector	148	169022	Spring Return Idler
26	110452X	Nut, Push	149	165898	Retainer Spring Yellow Zinc
27	130968X428	Shield, Deflector	150	19091210	Washer 9/32 x 3/4 x 10 Ga.
28	19111016	Washer 11/32 x 5/8 x 16 Ga.	152	181555	Cable Clutch 42 In
29	131491	Rod, Hinge	158	17720408	Screw Hex Thd Cut 1/4-20 x 1/2
30	173984	Screw Thdrol Washer Head	159	72140614	Bolt Rdhd Sqn 3/8-16 unc x 3/4
31	187690	Washer, Spacer	184	19131410	Washer 13/13 x7/8 x 10 Ga.
32	153535	Pulley, Mandrel	185	188234	Head Asm Cable Clutch
33	178342	Nut, Toplock, Flanged	--	130794	Mandrel Assembly (Includes Housing, Shaft and Shaft Hardware Only - Pulley Not Included)
34	STD533717	Bolt			Replacement Mower, Complete (Std. Deck-Order separately mulcher cover components key nos. 101 - 106).
36	131494	Pulley, Idler, Flat			
40	73900600	Nut Lock 3/8-16			
44	140088	Guard, Mandrel, L.H.	--	181268	
45	STD624003	Retainer			
46	137729	Screw, Thd. Roll 1/4-20 x 5/8			
48	133944	Washer, Hardened			
52	139888	Bolt, Shoulder 5/16-18 unc			
53	184907	Arm Assembly, Pad, Brake			
54	178515	Washer, Hardened			
55	155046	Arm, Idler			

**NOTE:** All component dimensions given in U.S. inches  
1 inch = 25.4 mm

# REPAIR PARTS

TRACTOR- -MODEL NO. 917. 277362

HYDRO GEAR TRANSAXLE - MODEL NUMBER 322-0510

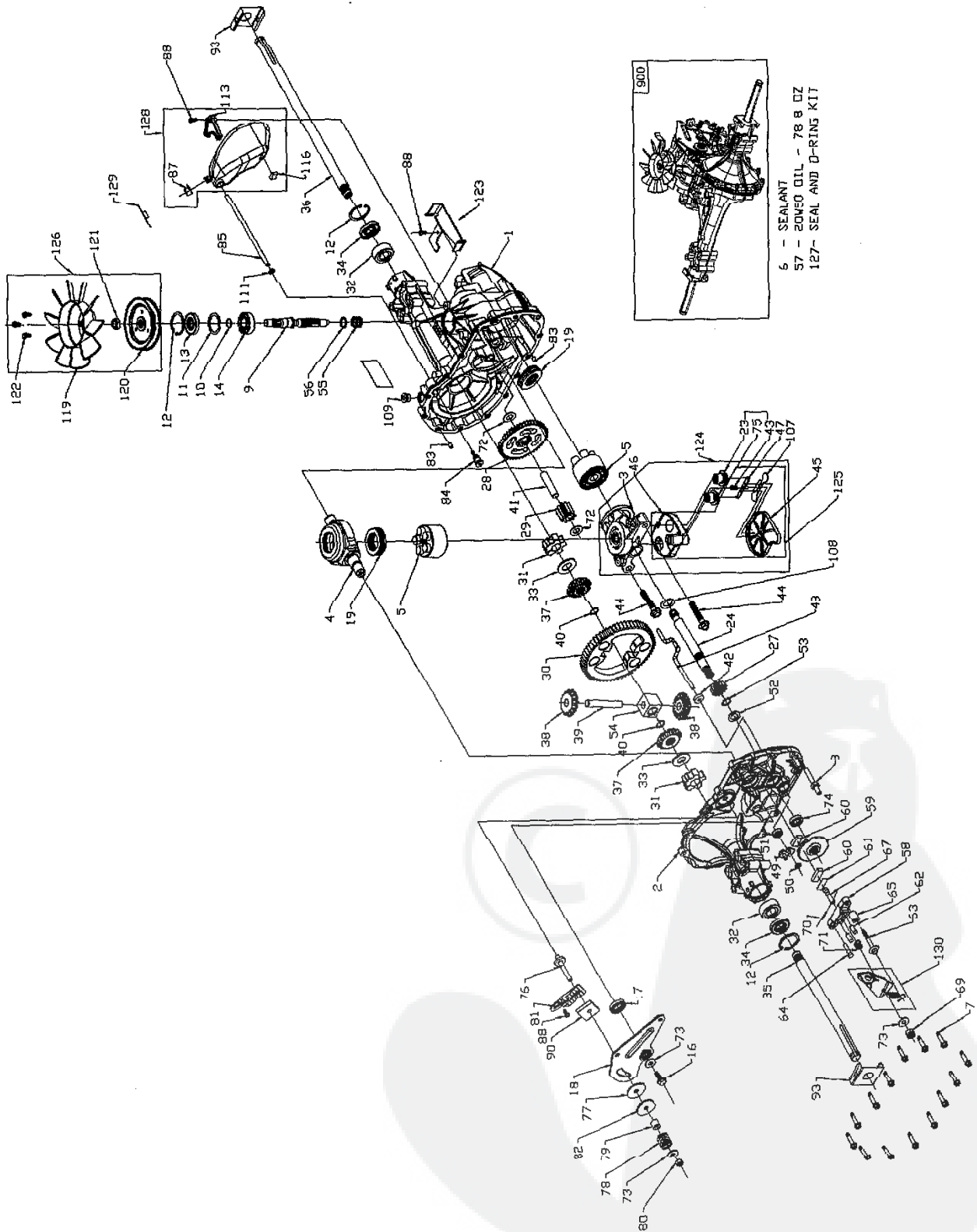

# REPAIR PARTS

## TRACTOR- -MODEL NO. 917, 277362

### HYDRO GEAR TRANSAXLE - MODEL NUMBER 322-0510

KEY PART NO.	NO.	DESCRIPTION	KEY PART NO.	NO.	DESCRIPTION
1	170351	Main Housing, Assembly	60	142883	Brake Puck
2	170352	Side Housing, Assembly	61	142882	Puck Plate
3	170353	Center Section, Assembly	62	142887	Brake Actuating Pin
4	170354	Swashplate, Trunion Machined	63	170410	HFHCS 1/4-20X2 W/Patch, Special Flange
5	169898	Block - Assembly	64	142892	Bolt, 1/4-20 X 1 W/Patch
6	170355	Sealant	65	170411	Spacer
7	170356	Hex Flange Screw 1/4-20 X 1.25	66	189386	Spring, Brake Arm Bias
8	170357	Stud, 5/16-24 Hex Double End	67	170413	SQ. HD. BOLT 5/16-24-Ribbed
9	170358	Shaft, Input	68	170414	Arm, Brake
10	170359	Ring - Retaining	69	170415	Slotted Hex Nut 5/16-24
11	170360	Spacer	70	170416	Cotter Pin 3/32 X 3/4
12	169870	Ring - Retaining	71	170417	Compression Spring Brake Anti-Drum
13	170361	Seal, Lip .67 X 1.58 X .276	72	170418	Washer, HT .5 I.D. X 1 O.D. X .032
14	173158	Ball Brg 17MM ID X 40MM OD X 12MM	73	142884	Flat - Washer 11/32 I.D. X 7/8 O.D.
16	170362	Hex FLange Head Screw 5/16-24 X 0.75	74	170419	Oil Seal .625 X 1.0 X .25
17	170363	Lip Seal 18 X 32 X 7	75	170420	Check Plug Assembly, .027, Washer
18	170364	Arm, Control	76	170421	Stud, 5/16-24 Friction Pack
19	173159	Bearing, 30X52X13 Thrust	77	170422	Puck, .330 X 1.50 X .0975
23	170365	Check Plug Assembly, Washer	78	142969	Spring, Helical Comp
24	170366	Shaft, Motor1	79	142980	Spacer
27	170367	Gear - Pinion, 13T	80	150778	Hex Lock Nut 5/16-24 UNJF (Nylon Insert)
28	170368	10T/48T GEAR	81	170423	Wedge, Friction Pack
29	170369	Gear, 10T Jackshaft	82	170424	Clip, Washer .316X1.50X.1046 (Plated)
30	170370	60T Bull Gear	83	161168	Pin, Standard Headless
31	170371	Sleeve Bearing .75 X 1.575 X .625	84	170425	Fitting, 5/16 Sae 5/32 Tube
		Sleeve Bearing (Outboard).75X1.750X.625	85	170426	Hose, Expansion Tank
33	142991	Washer, 3/4 ID X 1-1/2 OD X .13 THK	87	173160	Cap, Vent
34	170390	Lip Seal Axle Seal	88	170429	Bolt, Self Tapping 10-32 X 1/2
35	170391	Shaft, Axle .75 X 11.39 (Key, R.H.)	90	170430	Puck, Inner Wedge
36	170392	Shaft, Axle .75 X 16.99 (Key, L.H.)	93	170431	Spring Clip - Housing Thrust
37	150792	Miter Gear (SPLINED)	107	170432	Deflector
38	150793	Miter Gear 15T (0.5 ID)	108	170433	Washer, Motorshaft
39	150809	Shaft			.71ID X 1.15OD X .030THK
40	170393	Ring, Spiral Retaining	109	170434	Plug, Sae #6
41	170394	Pin, Jackshaft	111	170435	O-ring .07 x .301 I.D.
42	170395	Magnet, Ring	113	170437	Bracket, Support Expansion Tank
43	170396	Spring, Bypass	116	170438	Silicon Sponge
44	150797	Hydro mtg Screw 3/8-24 X 2.5 Long	119	173161	Fan
45	170397	Filter	120	170440	Pulley
46	170398	Base, Filter	122	173162	#12 T.F. Screw-Indented Hex Washer Head
47	170399	Actuator, Bypass	123	173163	Bracket Belt Keeper
48	170400	Rod, Bypass Actuator	124	170444	Center Section-Filter-Bypass Assembly
49	170401	Arm, Bypass	125	170445	Filter Assembly
50	170402	Retaining Ring .250 External	126	173164	Fan - Pulley Service Assembly
51	170403	Seal, Lip .741 X .250 X .250 TC	127	170447	Seal - O-ring Kit
52	170404	Flat Washer, 5/8 ID X 1.0 OD X .05 THK	128	173165	Kit, Expansion Tank
53	170405	Retaining Ring	900	171613	Transaxle, complete
54	170406	Bearing, Center Block			
55	142977	Spring - Helical Compression			
56	142978	Washer			
57	-----	20W-50 OIL 72.8 oz			
58	170407	Brake Yoke			
59	170408	Rotor, Brake			

**NOTE:** All component dimensions given in U.S. inches 1 inch = 25.4 mm

# REPAIR PARTS

TRACTOR--MODEL NO. 917, 277362

BRIGGS & STRATTON ENGINE -- MODEL NUMBER 31C707, TYPE NUMBER 0240-E1

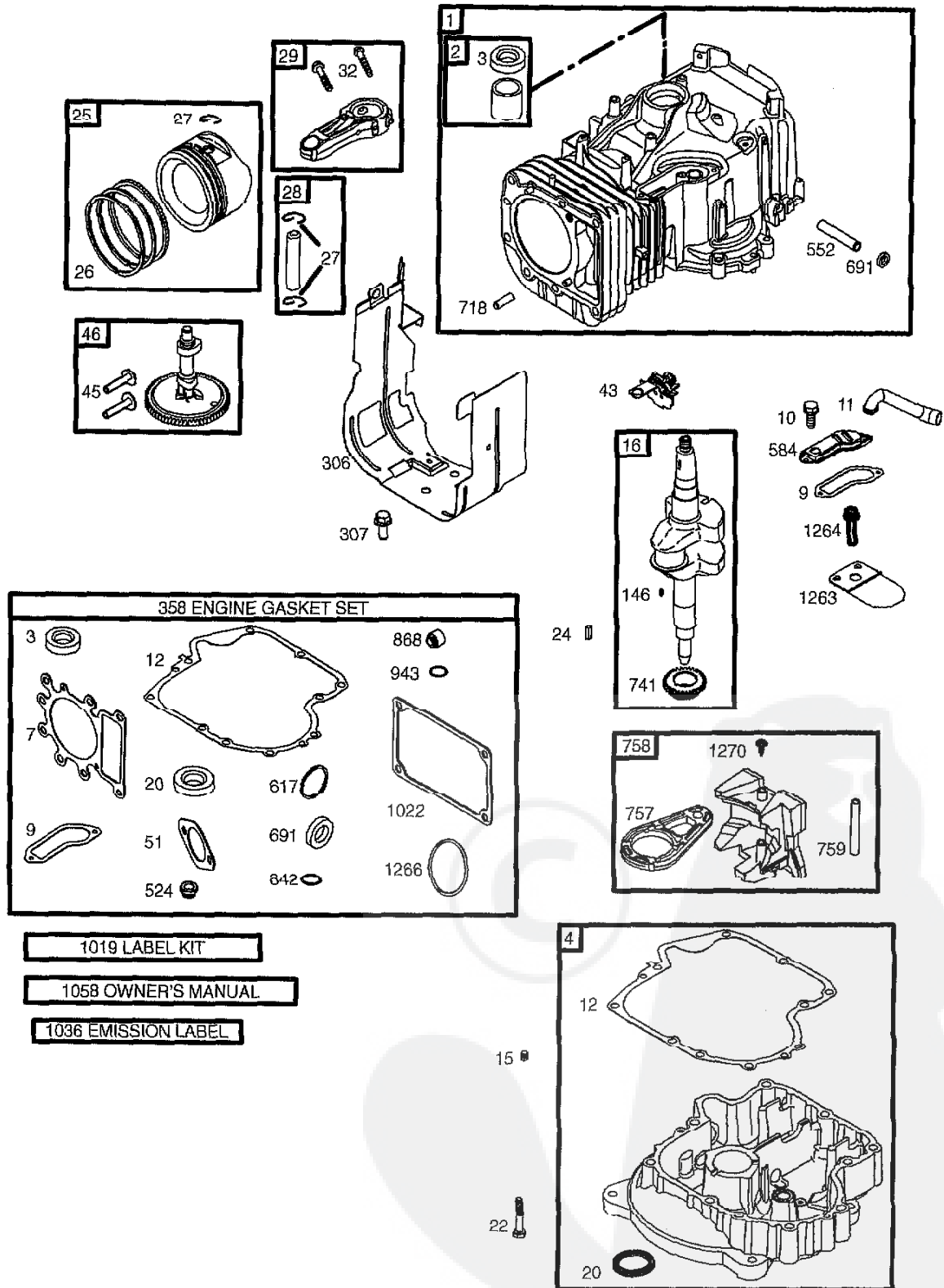

# REPAIR PARTS

TRACTOR- -MODEL NO. 917. 277362

BRIGGS & STRATTON ENGINE - - MODEL NUMBER 31C707, TYPE NUMBER 0240-E1

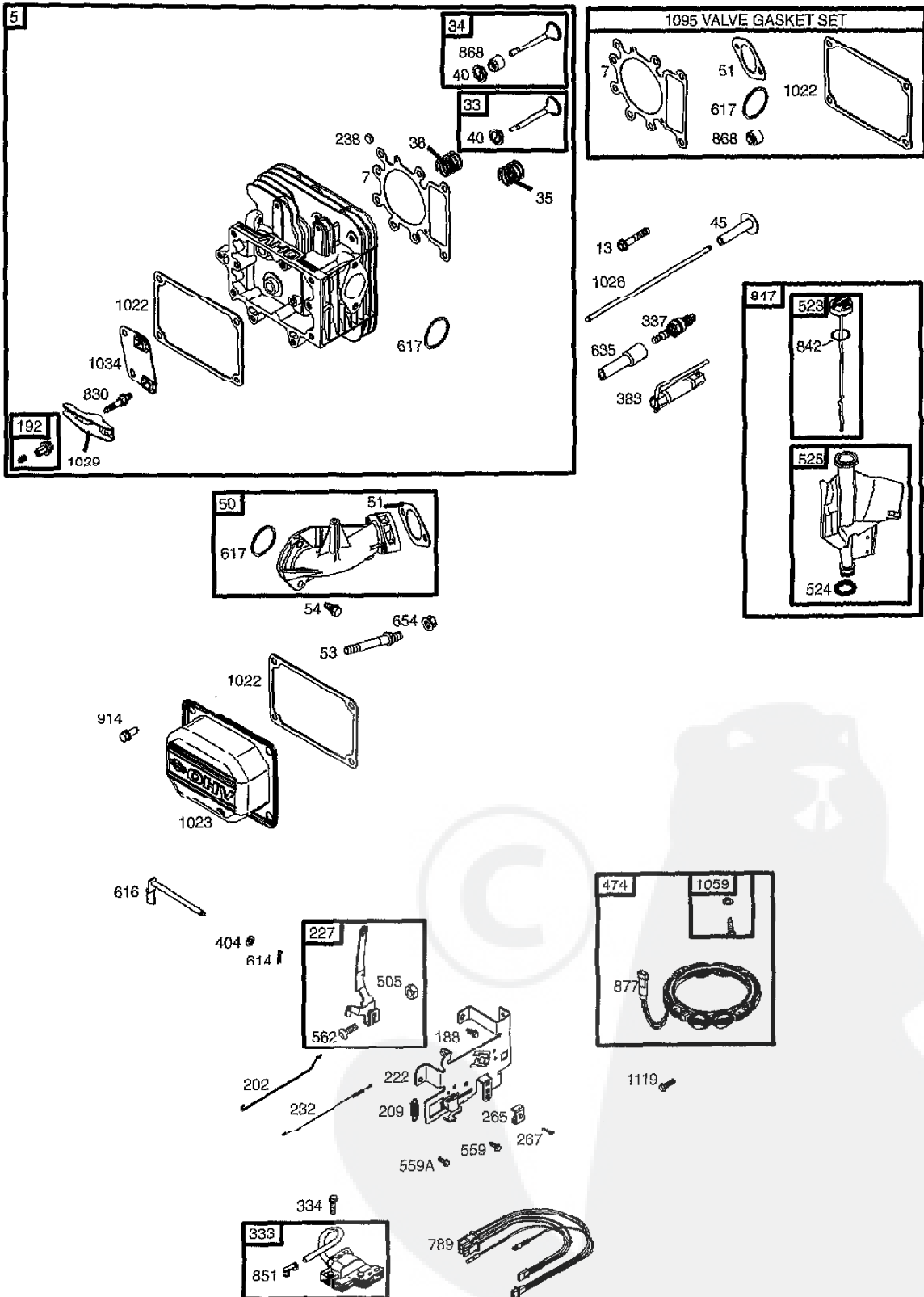

# REPAIR PARTS

TRACTOR- -MODEL NO. 917. 277362

BRIGGS & STRATTON ENGINE - - MODEL NUMBER 31C707, TYPE NUMBER 0240-E1

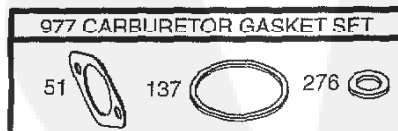
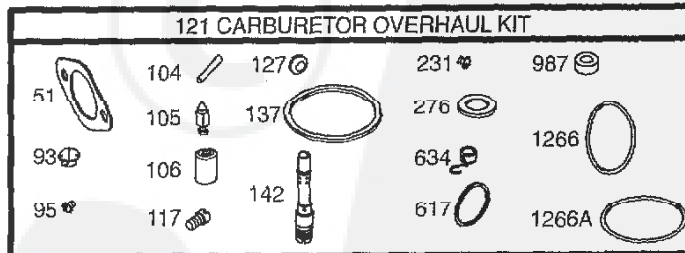
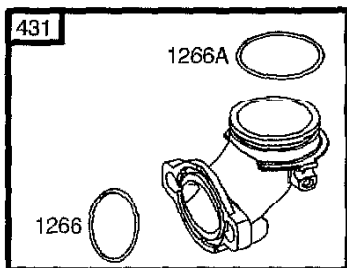
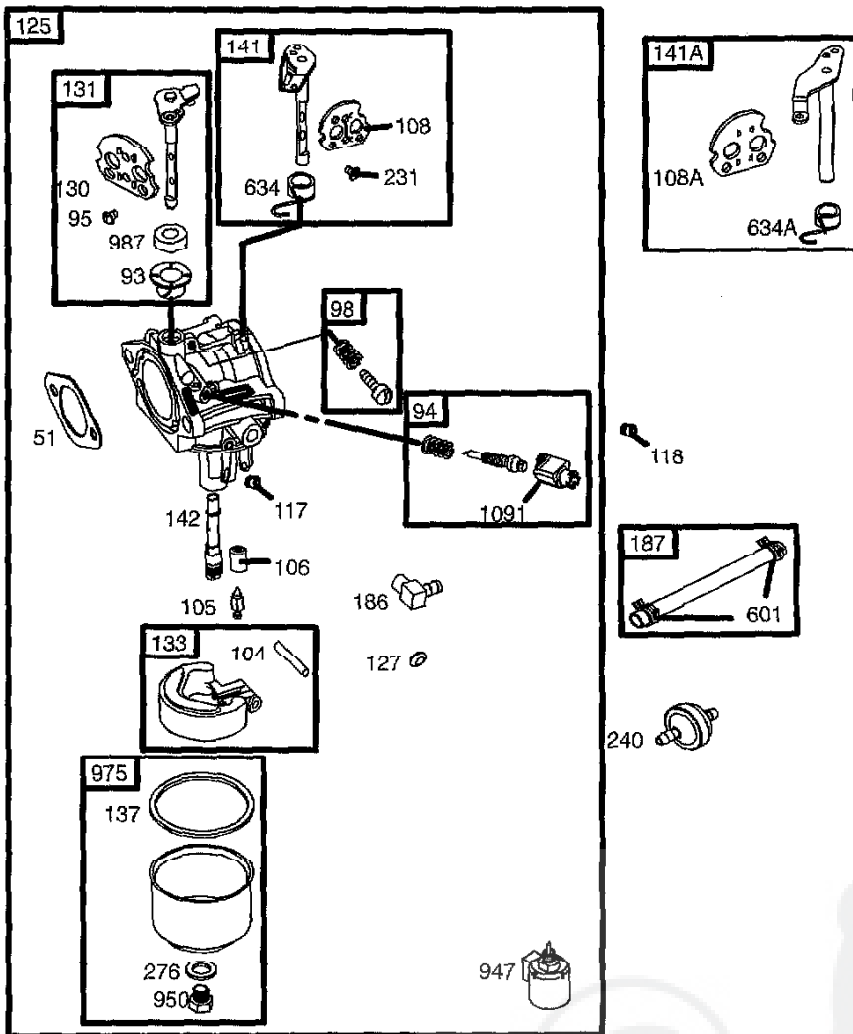



# REPAIR PARTS

TRACTOR- -MODEL NO. 917. 277362

BRIGGS & STRATTON ENGINE - - MODEL NUMBER 31C707, TYPE NUMBER 0240-E1

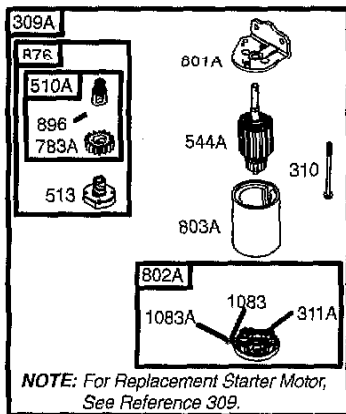
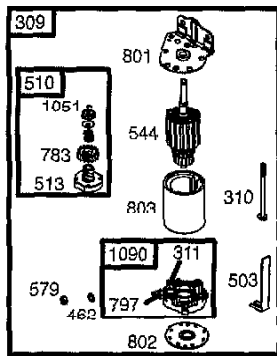
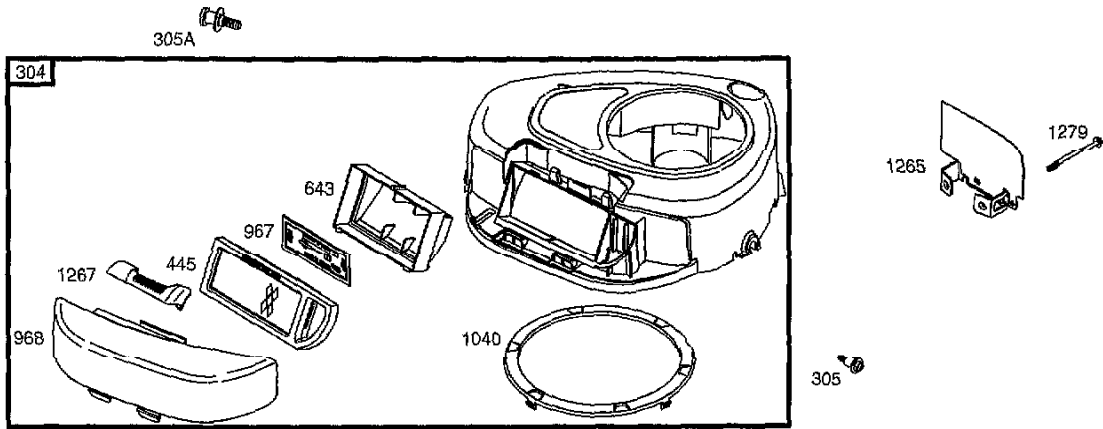

NOTE: For Replacement Starter Motor, See Reference 309.

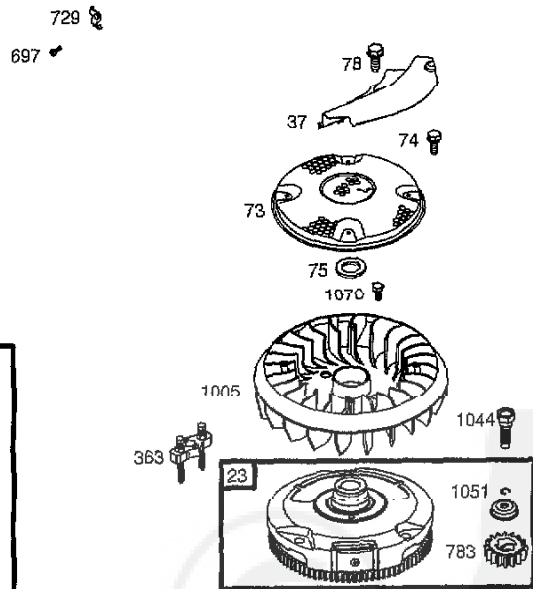

# REPAIR PARTS

## TRACTOR- -MODEL NO. 917. 277362

BRIGGS & STRATTON ENGINE - - MODEL NUMBER 31C707, TYPE NUMBER 0240-E1

KEY NO.	PART NO.	DESCRIPTION	KEY NO.	PART NO.	DESCRIPTION
1	697174	Cylinder Assembly	118	697492	Jet-Main (High Altitude)
2	399265	Kit-Bushing/Seal (Magneto Side)	121	697241	Kit-Carburetor Overhaul
3	391086	• Seal-Oil (Magneto Side)	125	697190	Carburetor
4	697106	Sump-Engine	127	695005	Plug-Welch
5	698147	Head-Cylinder	130	691750	Valve-Throttle
7	692410	•+ Gasket-Cylinder Head	131	494379	Kit-Throttle Shaft
9	697109	• Gasket-Breather	133	494381	Float-Carburetor
10	697157	Screw (Breather Assembly)	137	281165	Ø† Gasket-Float Bowl
11	697113	Tube-Breather	141	495097	Kit-Choke Shaft (Manual Choke)
12	697110	• Gasket-Crankcase	141A	495931	Kit-Choke Shaft (Choke A Matic)
13	690360	Screw (Cylinder Head)	142	697140	Ø Nozzle-Carburetor
15	690946	Plug-Oil Drain	146	691639	Key-Timing
16	697127	Crankshaft	186	692317	Connector-Hose
20	690947	• Seal-Oil (PTO Side)	187	691050	Line-Fuel (Cut to Required Length)
22	692125	Screw (Crankcase Cover/Sump)	188	691693	Screw (Control Bracket)
23	693557	Flywheel	192	691986	Adjuster-Rocker Arm
24	222698	Key Flywheel	202	691841	Link Mechanical Governor
25	697159	Piston Assembly (Standard)	209	692208	Spring-Governor
	697160	Piston Assembly (.010" Oversize)	222	694042	Bracket-Control
	697162	Piston Assembly (.020" Oversize)	227	691374	Lever-Governor Control
	697163	Piston Assembly (.030" Oversize)	231	691636	Screw (Choke Valve)
26	697164	Ring Set (Standard)	232	691842	Spring-Governor
	697165	Ring Set (.010" Oversize)	238	691843	Cap-Valve
	697171	Ring Set (.020" Oversize)	240	394358	Filter-Fuel
	697172	Ring Set (.030" Oversize)	265	691024	Clamp-Casing
27	697100	Lock-Piston Pin	267	695134	Screw (Casing Clamp)
28	697099	Pin-Piston	276	692255	Ø‡ Washer-Sealing
29	697126	Rod-Connecting (Standard)	304	698402	Housing-Blower
32	692852	Screw (Connecting Rod)	305	697102	Screw (Blower Housing)
33	495856	Valve-Exhaust	305A	697103	Screw (Blower Housing)
34	495857	Valve-Intake	306	697107	Shield-Cylinder
35	691279	Spring-Valve (Intake)	307	691003	Screw (Cylinder Shield)
36	691279	Spring-Valve (Exhaust)	309	693551	Motor-Starter
37	697352	Guard-Flywheel	309A	-----	Motor-Starter (For Replacement Starter Motor, See Reference 309)
40	691752	Retainer-Valve	310	690323	Bolt (Starter Motor)
43	691968	Slinger-Governor/Oil	311	497608	Brush Set
45	690564	Tappet-Valve	311A	395538	Brush Set
46	697687	Camshaft	333	102341	Armature-Magneto
48	697761	Short Block (31C707 0240-E2 Replacement Engine-art not available)	334	691061	Screw (Magneto Armature)
50	690193	Manifold-Intake	337	691043	Plug-Spark
51	692137	•Ø‡+ Gasket-Intake	358	697191	Gasket Set-Engine
53	690227	Stud (Carburetor)	363	19203	Flywheel Puller
54	691148	Screw (Intake Manifold)	383	89838	Wrench-Spark Plug
73	697384	Screen-Rotating	404	691691	Washer (Governor Crank)
74	697987	Screw (Rotating Screen)	431	697122	Elbow-Intake
75	690582	Washer (Flywheel)			
78	691003	Screw (Flywheel Guard)			
93	690602	Ø Bushing-Throttle Shaft			
94	498030	Kit-Idle Mixture			
95	691636	Screw (Throttle Valve)			
98	495800	Kit-Idle Speed			
104	690525	Ø Pin-Float Hinge			
105	231855	Ø Valve-Float Needle			
106	690577	Ø Seat-Inlet			
108	690464	Valve-Choke (Manual Choke)			
108A	692344	Valve-Choke (Choke A Matic)			
117	694352	Ø Jet-Main (Standard)			

RPM Settings:

Low Speed: 1900-2100  
High Speed: 3000-3200

- Included in Engine Gasket Set, Key No. 358
- Ø Included in Carburetor Overhaul Kit, Key No. 121
- ‡ Included in Carburetor Gasket Set, Key No. 977
- + Included in Valve Gasket Set, Key No. 1095

NOTE: All component dimensions given in U.S. inches 1 inch = 25.4 mm

# REPAIR PARTS

## TRACTOR- -MODEL NO. 917. 277362

BRIGGS & STRATTON ENGINE - - MODEL NUMBER 31C707, TYPE NUMBER 0240-E1

KEY NO.	PART NO.	DESCRIPTION	KEY NO.	PART NO.	DESCRIPTION
445	698083	Filter-Air Cleaner Cartridge	876	495877	Kit-Pinion Spring
462	691261	Washer (Starter Cable)	877	393456	Wire-Connector/Alternator
474	696459	Alternator	896	691641	Pin-Drive Retainer
503	691532	Strap-Starter	914	690960	Screw (Rocker Cover)
505	691251	Nut (Governor Control Lever)	947	694393	Solenoid-Fuel
510	693699	Drive-Starter	950	691657	Screw (Float Bowl)
510A	497606	Drive-Starter	967	697015	Filter-Pre Cleaner
513	692024	Clutch-Drive	968	698403	Cover-Air Cleaner
523	697086	Dipstick	975	495933	Bowl-Float
524	691032	• Seal-Dipstick Tube	977	690192	Gasket Set-Carburetor
525	697184	Tube-Dipstick	987	691326	Ø Seal-Throttle Shaft
544	692034	Starter-Armature	1005	697853	Fan-Flywheel
544A	390837	Starter-Armature	1019	697143	Kit-Label
552	697144	Bushing-Governor Crank	1022	272475	•+ Gasket-Rocker Cover
559	697561	Screw (Remote Choke Stop)	1023	692492	Cover-Rocker Arm
559A	693675	Screw (Remote Choke Stop)	1026	692003	Rod-Push (Intake)
562	691119	Bolt (Governor Control Lever)		692011	Rod-Push (Exhaust)
579	691029	Nut (Starter Cable)	1029	691751	Arm-Rocker
584	697112	Cover-Breather Passage	1034	690822	Guide-Push Rod
601	95162	Clamp-Hose	1036	695700	Label-Emission
614	691620	Pin-Cotter	1040	609368	Plate Trim
616	692012	Crank-Governor	1044	691658	Screw (Flywheel)
617	692138	Ø • Seal-O Ring (Intake Manifold)	1051	691265	Ring-Retaining
634	690801	Ø Spring/Seal Assembly (Manual Choke)	1058	275038	Owner's Manual
634A	690802	Ø Spring/Seal Assembly (Choke A Matic)	1059	698516	Kit-Screw/Washer
635	691909	Boot-Spark Plug	1070	690372	Screw (Flywheel Fan)
643	698401	Retainer-Air Filter	1083	691626	Nut (Starter Terminal)
654	690958	Nut (Carburetor)	1083A	690958	Nut (Starter Terminal)
691	692407	• Seal-Governor Shaft	1090	691293	Retainer-Brush
697	690372	Screw (Drive Cap)	1091	691333	Cap-Limiter
718	690959	Pin-Locating	1095	690190	Gasket Set-Valve
729	691224	Clip-Wire	1119	691183	Screw (Alternator)
741	697128	Gear-Timing	1263	697124	Reed-Breather
757	697607	Link-Counterweight	1264	697104	Screw (Breather Reed)
758	697134	Counterweight	1265	697125	Support-Blower Housing
759	697392	Pin-Counterweight	1266	691917	•Ø Seal-O Ring (Intake Elbow)
783	693713	Gear-Pinion	1266A	697123	Ø Seal-O Ring (Intake Elbow)
783A	693059	Gear-Pinion	1267	697575	Latch-Blower Housing
789	698329	Harness-Wiring	1270	697156	Plug-AVS Counterweight
797	693167	Nut (Brush Retainer)	1279	690960	Screw (Blower Housing Support)
801	691283	Cap-Drive			RPM Settings:
801A	394856	Cap-Drive			Low Speed: 1900-2100
802	691286	Cap-End			High Speed: 3000-3200
802A	395537	Cap-End			
803	693757	Housing-Starter			• Included in Engine Gasket Set, Key. No. 358
803A	398159	Housing-Starter			Ø Included in Carburetor Overhaul Kit, Key. No. 121
830	691095	Stud (Rocker Arm)			‡ Included in Carburetor Gasket Set, Key. No. 977
842	691031	• Seal-O Ring (Dipstick Tube)			+ Included in Valve Gasket Set, Key. No. 1095
847	697611	Dipstick/Tube Assembly			
851	692424	Terminal-Spark Plug			
868	690968	•+ Seal-Valve			

NOTE: All component dimensions given in U.S. inches 1 inch = 25.4 mm

#### **LIMITED WARRANTY ON CRAFTSMAN RIDING EQUIPMENT**

For two (2) years from the date of purchase, if this Craftsman Riding Equipment is maintained, lubricated and tuned up according to the instructions in the owner's manual. Sears will repair or replace free of charge any parts that are found to be defective in material or workmanship according to the guidelines of coverage listed below. Sears will also provide free labor for these applicable warranted parts for the two full years. During the first 30 days of purchase, there will be no charges to service the product at your home for issues covered by this warranty. (See exclusions below). For your convenience, IN HOME warranty service will still be available after the first 30 days of purchase, but a trip charge will apply. This charge will be waived if the Craftsman product is dropped off at an authorized Sears location. For the nearest authorized Sears location, please call 1-800-4-MY-HOME®. This warranty applies only while this product is within the United States.

This Warranty does not cover:

- Expendable items which become worn during normal use, including but not limited to blades, spark plugs, air cleaners, belts, and oil filters.
- Standard Maintenance Servicing, oil changes, or tune-ups
- Tire replacement or repair caused by punctures from outside objects, such as nails, thorns, stumps, or glass.
- Repairs necessary because of operator abuse, including but not limited to, damage caused by towing objects beyond the capability of the riding equipment, impacting objects that bend the frame or crankshaft, or over-speeding the engine.
- Repairs necessary because of operator negligence, including but not limited to, electrical and mechanical damage caused by improper storage, failure to use the proper grade and amount of engine oil, failure to keep the deck clear of flammable debris, or failure to maintain the equipment according to the instructions contained in the owner's manual.
- Engine (fuel system) cleaning or repairs caused by fuel determined to be contaminated or oxidized (stale). In general, fuel should be used within 30 days of its purchase date.
- Normal deterioration and wear of the exterior finishes, or product label replacement.
- Riding equipment used for commercial or rental purposes.

#### **LIMITED WARRANTY ON BATTERY**

For ninety (90) days from date of purchase, if any battery included with this riding equipment proves defective in material or workmanship and our testing determines the battery will not hold a charge, Sears will replace the battery at no charge. During the first 30 days of purchase, there will be no charges to replace the battery at your HOME. After the first 30 days, for your convenience, IN-HOME warranty service will still be available but a trip charge will apply. This charge will be waived if the Craftsman product is dropped off at an authorized Sears location. For the nearest authorized Sears location, please call 1-800-4-MY-HOME®.

This battery warranty applies only while this product is within the United States.

This warranty gives you specific legal rights, and you may also have other rights, which vary, from state to state.

Sears, Roebuck and Co., Dept. 817WA, Hoffman Estates, IL 60179



**CRAFTSMAN®**