

REPAIR PARTS MANUAL
MODEL NO. 253650
Lawn Tractor

CRAFTSMAN®

HOW TO USE THIS MANUAL

This manual is designed to provide the customer with a means to identify the parts on his/her tractor when ordering repair parts. The illustrations may or may not represent the actual assemblies; therefore, it is not recommended to use this manual as a guide to assemble or disassemble the tractor. Some hardware and parts are drawn larger in order to more readily identify them.

Each tractor has its own model number.

The model number for your tractor can be found on the fender under the seat.

When ordering parts, always give the following information:

- Product - "Tractor"
- Model Number - "253650"
- Part Number
- Part Description

TABLE OF CONTENTS

SCHEMATIC	3
ELECTRICAL.....	4-5
CHASSIS	6-7
DRIVE.....	8-9
STEERING	10-11
SEAT	12
DECALS.....	13
ENGINE.....	14-15
MOWER LIFT.....	16-17
MOWER DECK.....	18-19
TRANSAXLE BREAKDOWN	20-21
ENGINE BREAKDOWN.....	22-27
WARRANTY.....	BACK COVER

TRACTOR- -MODEL NO. 917.253650

SCHEMATIC

SCH11

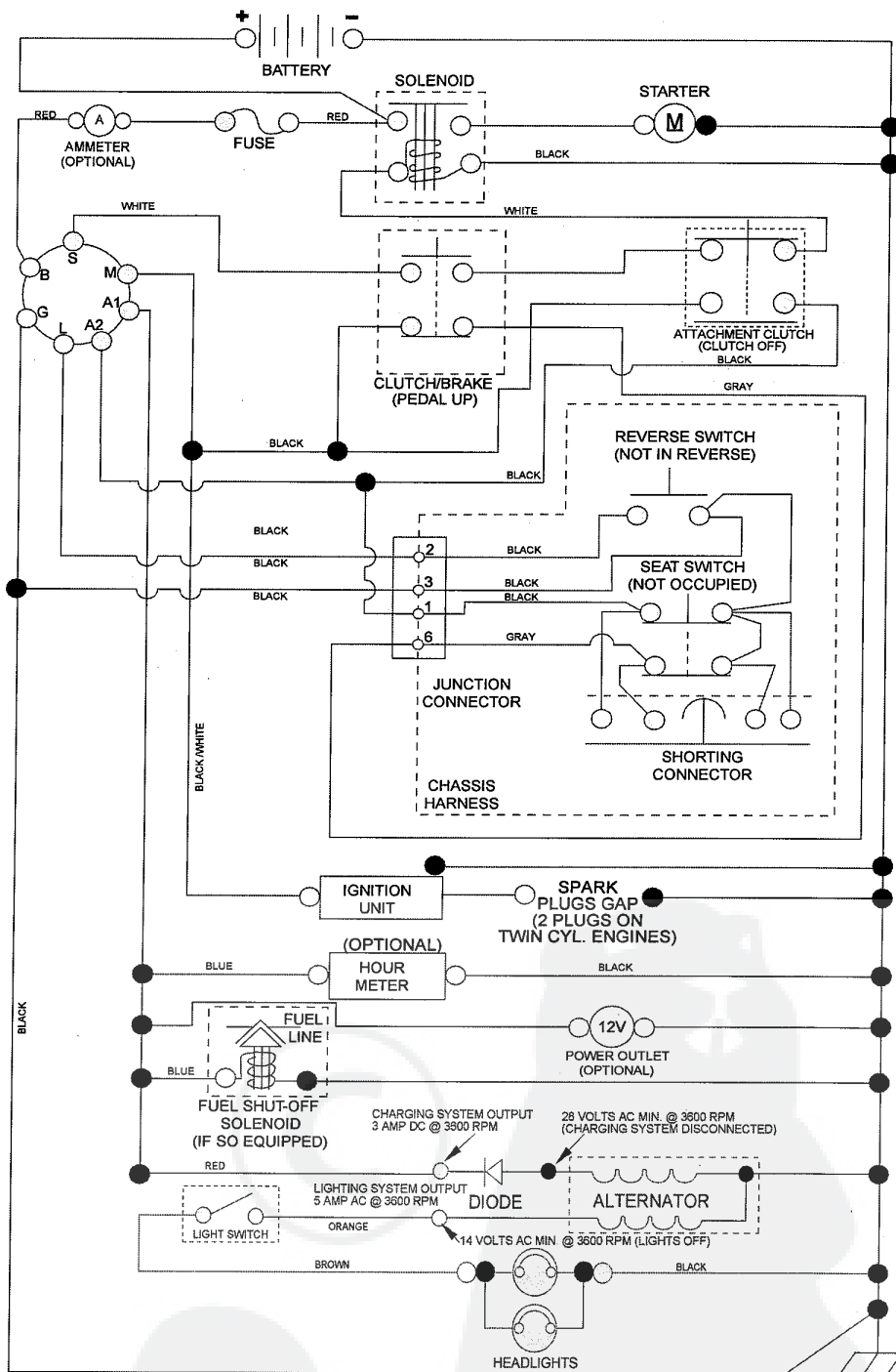

NOTE
YOUR TRACTOR IS EQUIPPED WITH A SPECIAL ALTERNATOR SYSTEM. THE LIGHTS ARE NOT CONNECTED TO THE BATTERY, BUT HAVE THEIR OWN ELECTRICAL SOURCE. BECAUSE OF THIS, THE BRIGHTNESS OF THE LIGHTS WILL CHANGE WITH ENGINE SPEED. AT IDLE THE LIGHTS WILL DIM. AS THE ENGINE IS SPEEDED UP, THE LIGHTS WILL BECOME THEIR BRIGHTEST.

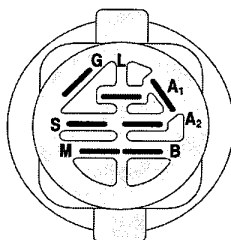

IGNITION SWITCH

POSITION	CIRCUIT	"MAKE"
OFF	M+G+A1	
RUN/OVERRIDE	B+A1	
RUN	B+A1	L+A2
START	B + S + A1	

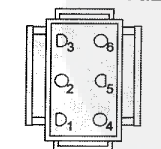

CHASSIS HARNESS CONNECTOR (MATING SIDE)

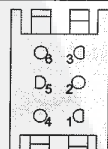

DASH HARNESS CONNECTOR (MATING SIDE)

WIRING INSULATED CLIPS
NOTE: IF WIRING INSULATED CLIPS WERE REMOVED FOR SERVICING OF UNIT, THEY SHOULD BE RE-INSTALLED TO PROPERLY SECURE YOUR WIRING.

NON-REMOVABLE CONNECTIONS

REMOVABLE CONNECTIONS

REPAIR PARTS

TRACTOR- -MODEL NO. 917.253650

ELECTRICAL

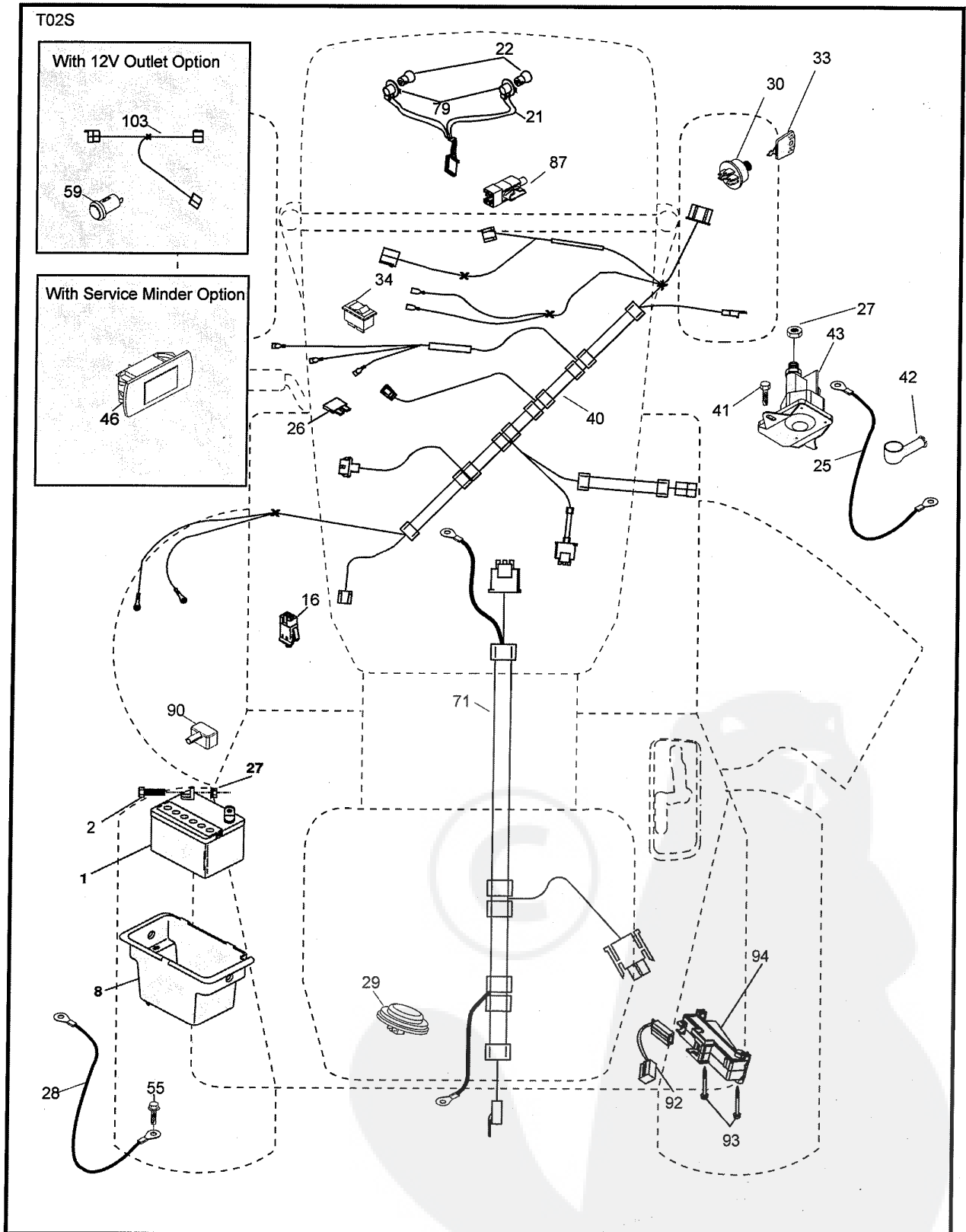

REPAIR PARTS

TRACTOR- -MODEL NO. 917.253650

ELECTRICAL

KEY NO.	PART NO.	DESCRIPTION
1	163465	Battery
2	74760412	Bolt Hex Hd 1/4-20 unc x 3/4
8	193228	Box Battery
16	176138	Switch Interlock Push-In
21	400252	Harness Socket Light w/4152J
22	4152J	Bulb Light
25	412894	Cable Starter
26	175158	Fuse
27	73510400	Nut Keps Hex 1/4-20 unc
28	198885	Cable, Ground
29	401545	Switch, Seat
30	193350	Switch, Ign
33	411934	Key/Chain
34	110712X	Switch Light / Reset
40	401098	Harness Ign. Dash
41	17720408	Screw Thd Cut 1/4-20 x 1/2
42	131563	Cover, Terminal
43	192507	Solenoid
55	17060512	Screw Thdrol 5/16-18 x 3/4 TYTT
71	400449	Harness Ign. Chassis
79	175242	Bulbholder Asm. Incan Descent
87	197802	Switch Interlock Clutch Cable
90	400725	Cover Terminal Battery
92	196615	Harness Pigtail Reverse Switch
93	192540	Screw Plastite 10 - 14 x 2 00
94	191834	Module Reverse Ros

NOTE: All component dimensions given in U.S. inches.
1 inch = 25.4 mm.

REPAIR PARTS

TRACTOR- -MODEL NO. 917.253650

CHASSIS AND ENCLOSURES

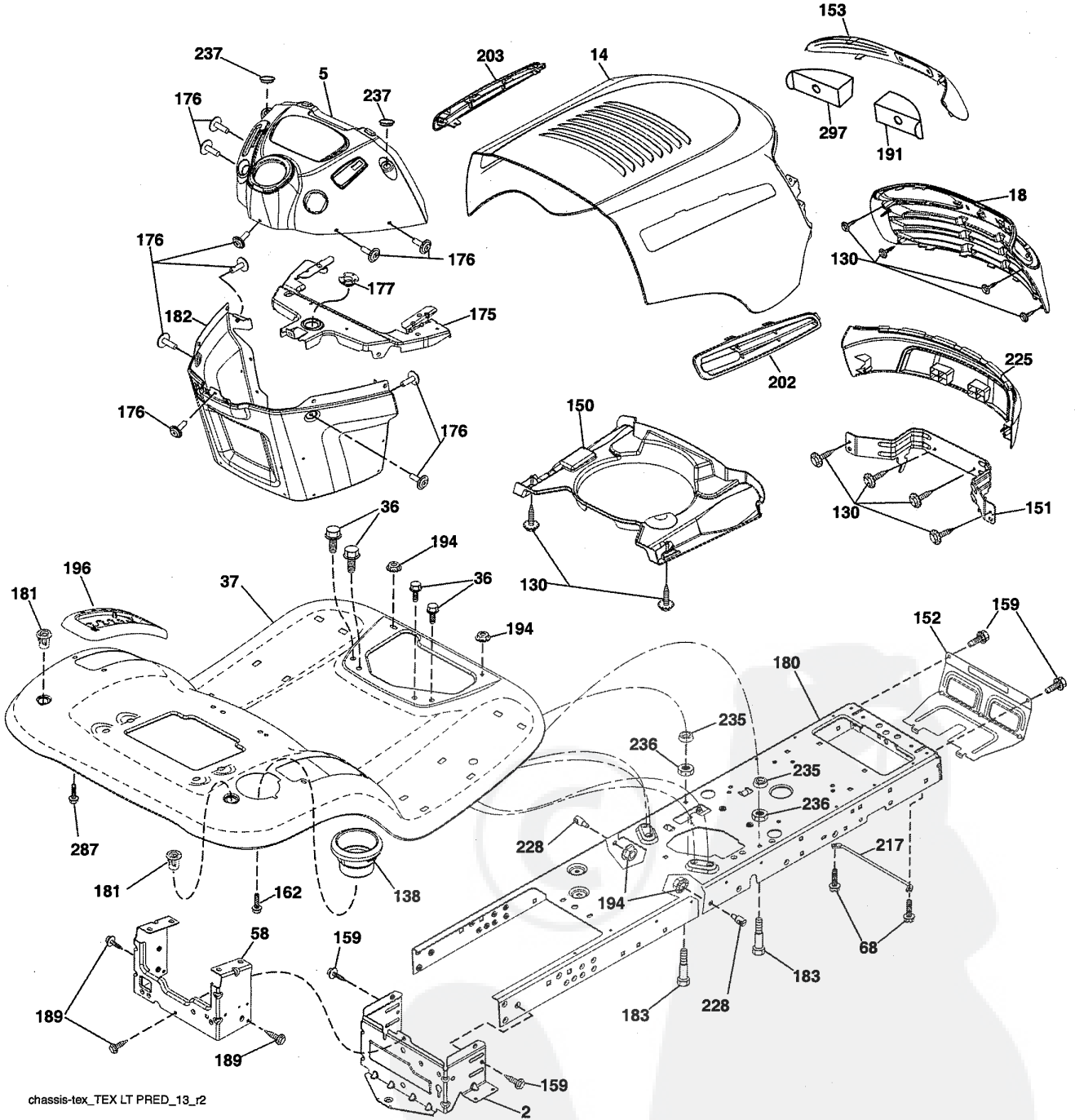

chassis-tex_TEX LT PRED_13_r2

REPAIR PARTS

TRACTOR- -MODEL NO. 917.253650

CHASSIS AND ENCLOSURES

KEY NO.	PART NO.	DESCRIPTION
2	412282	Drawbar Lower
5	408874X428	Dash
14	198416X613	Hood
18	423156	Grille
36	17060512	Screw 5/16-18 x 3/4
37	414872X613	Fender
58	412280	Drawbar Upper
68	17490508	Screw Thdrol 5/16-18 x 1/2
130	416358	Screw #10 x 0.750
138	193224X428	Cupholder
150	400267	Duct Heat Hood
151	187568	Bracket Pivot
152	194329	Shield Browning/Debris
153	400550X599	Lens
159	17000612	Screw Hexwsh Thdrol 3/8-16 x 3/4
162	142432	Screw Hex Wsh Hi-Lo 1/4 x 1/2
175	199472	Crossmember
176	400776	Screw 10-24 x 5/8 Wshd Qdrx
177	195228	Bushing Steering
180	194260	Chassis
181	193102X428	Bushing Mtg. Fender Crgo.
182	407176	Dash Lower
183	74780520	Bolt Fin Hex 5/16-18 x 1-1/4
189	17000512	Screw 5/16-18 x 3/4
191	416502	Insert Reflective RH
194	73900500	Nut Lock Hex Flange 5/16-18
196	414579	Console Asm. Deck Lift
202	423173	Vent Hood Side Panel RH
203	423172	Vent Hood Side Panel LH
217	409167	Rod Pivot Hood
225	400549X613	Bumper
228	195161	Stud Fastener
235	406129	Spacer Fender
236	73930500	Nut Center Lock 5/16-18
237	403704	Plug Mount Cargo
287	17600406	Screw 1/4-20 x 3/8
297	401827	Insert Reflective LH

NOTE: All component dimensions given in U.S. inches.
1 inch = 25.4 mm.

REPAIR PARTS

TRACTOR- -MODEL NO. 917.253650

DRIVE

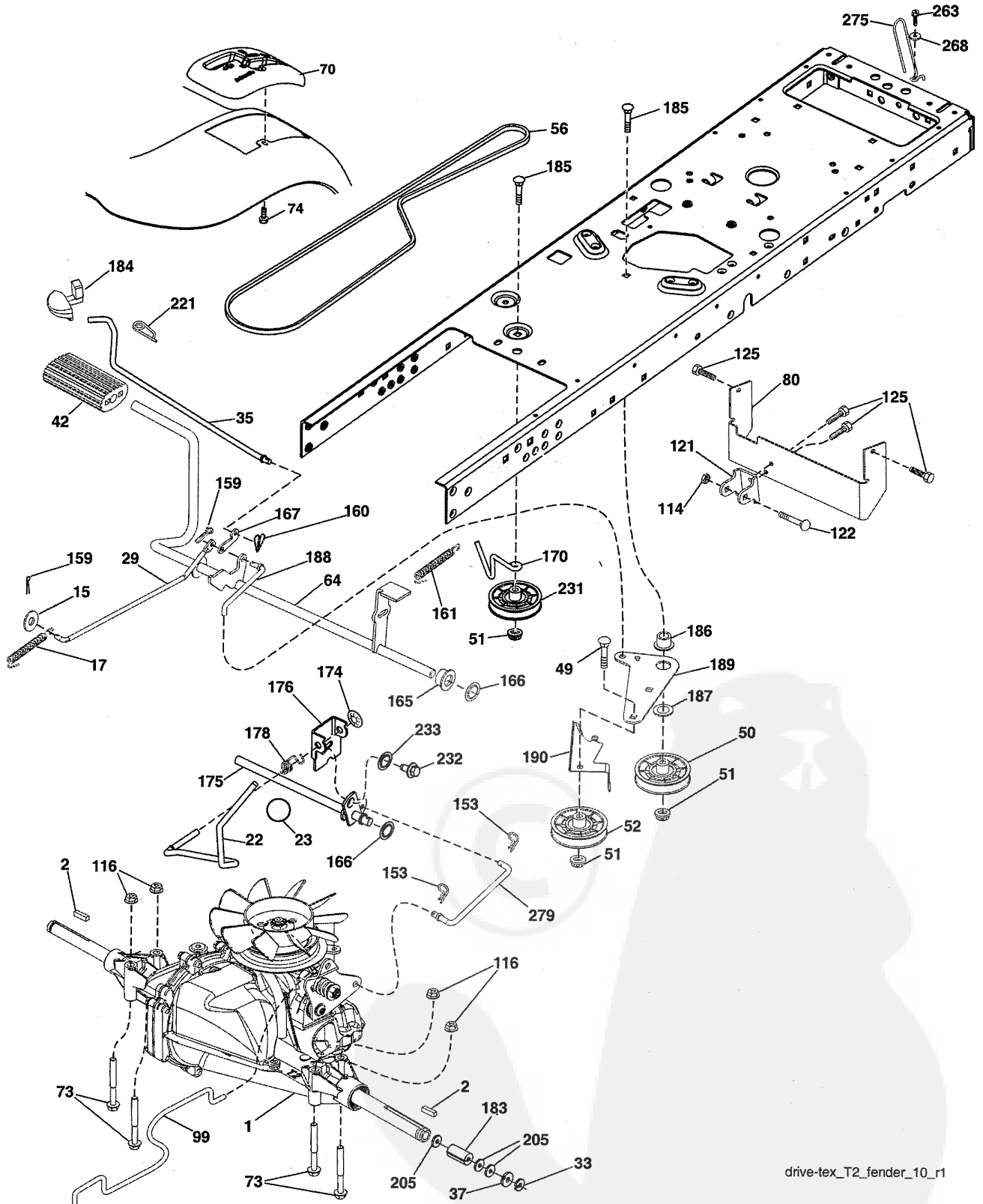

drive-tex_T2_fender_10_r1

REPAIR PARTS

TRACTOR- -MODEL NO. 917.253650

DRIVE

KEY NO.	PART NO.	DESCRIPTION	KEY NO.	PART NO.	DESCRIPTION
1	-----	Transaxle, Hydro Gear T2-AABC-1X1A-1GX1 (See Transaxle Breakdown)	160	169484	Retainer Clip
2	123583X	Key Square	161	105709X	Spring, Return, Clutch
15	19131316	Washer 13/32 x 13/16 x 16 Ga.	165	196212	Bushing
17	197296	Spring, Brake	166	197290	Nut Push .625
22	197660	Rod Shift	167	405257	Latch Brake Parking
23	106933X	Knob	170	413430	Keeper V-Idler
29	423239	Rod, Brake	174	197289	Nut Push
33	12000001	Ring E	175	408539	Shaft Asm Shift
35	401031	Rod, Brake, Park Control	176	196214	Arm Clevis Rod Shift
37	121749X	Washer 25/32 x 1-1/4 x 16 Ga.	178	197456	Spring Shift
42	8883R	Cover, Foot Pedal	183	156972	Spacer Axle
49	72110614	Bolt	184	199996X505	Handle Parking Brake
50	194327	Pulley Idler Flat	185	72110622	Bolt
51	73900600	Lock Nut 3/8-16	186	194321	Spacer Retainer
52	194326	Idler V-Groove 910" Offset	187	19133210	Washer
56	125907X	V-Belt, Drive	188	194323	Link Clutch Ground Drive
64	196200	Shaft Asm. Pedal Brake Control	189	194317	Bellcrank Ground Drive
70	193220X428	Console	190	194318	Keeper Bellcrank Ground Drive
73	74490544	Bolt Hex 5/16-18 Gr. 5	205	121748X	Washer 25/32 x 1-5/8 x 16 Ga.
74	142432	Screw 1/4 x 1/2	221	403187	Retainer Spring Clip Handle
80	408393	Strap Torque	231	407287	Idler V-Groove 1.688" Offset
99	408418	Rod Spring Bypass	232	74780716	Bolt 7/16-14 x 1 Gr. 5
114	73800500	Nut Lock 5/16-18 unc	233	405296	Washer Serrated
116	73900500	Nut Lock Hex Flange 5/16-18	263	17000612	Screw Hexwsh Thdr 3/8-16 x 3/4
121	175611	Bracket Strap Torque	268	19131614	Washer 13/32 x 1 x 14 Ga.
122	72010520	Bolt 5/16-18 x 2.50	275	182402	Guard Muffler
125	17000512	Screw 5/16-18 x 3/4	279	424155	Link Shift
153	4497H	Retainer Spring 1"			
159	76020412	Pin Cotter 1/8 x 3/4			

NOTE: All component dimensions given in U.S. inches
1 inch = 25.4 mm

REPAIR PARTS

TRACTOR- -MODEL NO. 917.253650

STEERING ASSEMBLY

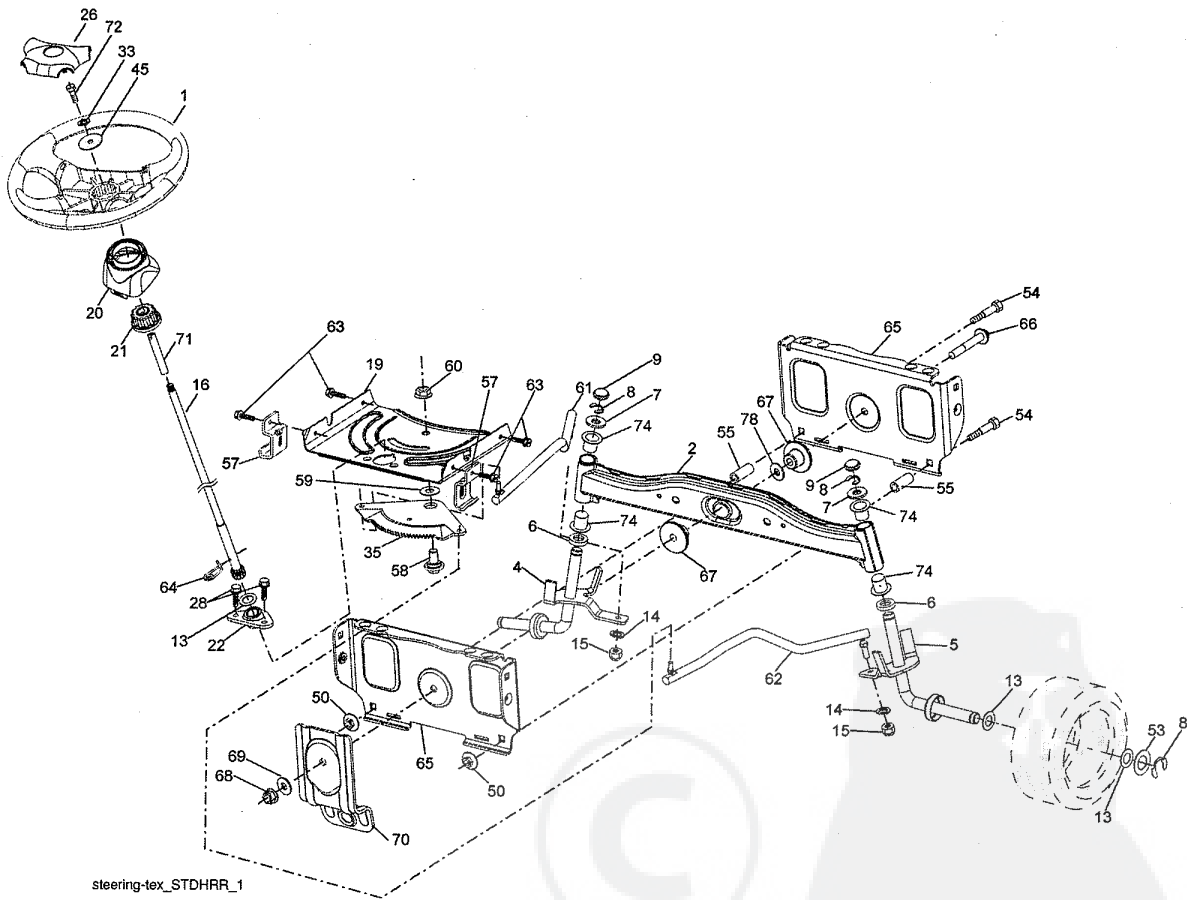

REPAIR PARTS

TRACTOR- -MODEL NO. 917.253650

STEERING ASSEMBLY

KEY NO.	PART NO.	DESCRIPTION
1	414803X428	Wheel, Steering
2	418168	Axle Asm., Front
4	403087	Spindle Asm., LH
5	403088	Spindle Asm., RH
6	6266H	Washer Thrust
7	121748X	Washer 25/32 x 1-5/8 x 16 Ga.
8	12000029	Ring, Klip #T5304-75
9	121232X	Cap, Spindle
13	121749X	Washer 25/32 x 1-1/4 x 16 Ga.
14	STD551137	Washer, Lock Hvy Hlcl Spr 3/8
15	73540600	Nut, Crown Lock 3/8-24 unf
16	196074	Shaft Steering
19	194729	Plate Steering
20	400803X428	Boot, Steering
21	186737	Adapter, Wheel Steering
22	194845	Bushing, Strg. Blk
26	414852X428	Insert, Wheel Steering
28	17000612	Screw 3/8-16 x 3/4
33	10040500	Washer Lock Hvy HLCL Spr 5/16
35	194732	Gear, Sector Plate
45	19113812	Washer 11/32 ID x 2 3/8
50	73900600	Nut Lock Flg 3/8-16 unc
53	188967	Washer Hardened .793 x 1.637 x .060
54	74760636	Bolt Hex 3/8-16 unc x 2-1/4
55	414736	Spacer Brace Axle
57	407465	Bracket Upstop
58	194747	Bolt Shoulder Sector Pivot CFM
59	194748	Washer Thrust Sector Steering
60	73971000	Nut Flange Lock 5/8-11
61	194740	Draglink LH
62	194741	Draglink, RH
63	17000512	Screw 5/16-18 x 3/4
64	199849	Retainer Clip Spring Steering
65	194734	Brace Axle Front
66	71020748	Bolt Hex Fghd 7/16-14 x 3 Serr
67	194737	Bushing PM Front Axle
68	73900700	Nut Lock Flange 7/16-14 Gr. 5
69	199162	Washer 1.5 x .505 x .118
70	196197	Bracket Deck Susp. Front
71	196075	Shaft Exten. Strg. Spline Tex
72	74780572	Bolt Fin Hex 5/16-18 unc x 4.5 G5
74	3366R	Bearing Col Strg Blk
78	57079	Washer Thrust 515 x .750 x .003

NOTE: All component dimensions given in U.S. inches.
1 inch = 25.4 mm.

REPAIR PARTS

TRACTOR- -MODEL NO. 917.253650

SEAT ASSEMBLY

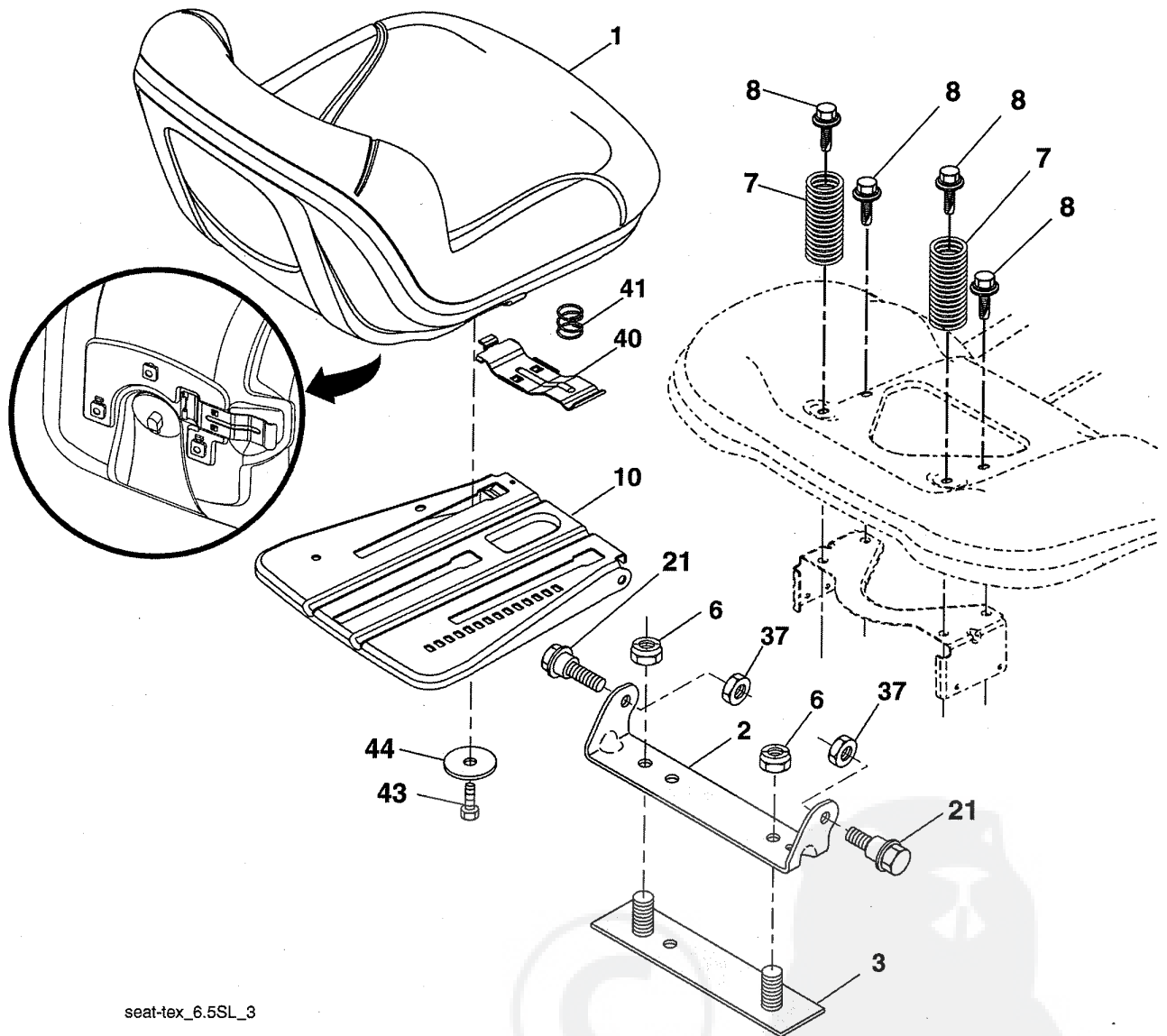

seat-tex_6.5SL_3

KEY NO.	PART NO.	DESCRIPTION
1	423644	Seat
2	180166	Bracket Pivot Fender
3	140675	Strap, Asm Fender
6	STD541437	Nut, Lock w/Ins. 3/8-16 unc
7	124181X	Spring, Seat Cprsn
8	171877	Bolt 5/16-18 unc x 3/4 w/Sems
10	196977	Pan, Seat
21	171852	Bolt, Shoulder 5/16-18

KEY NO.	PART NO.	DESCRIPTION
37	STD541431	Nut, Lock 5/16-18 unc
40	197661	Handle Slide
41	198200	Spring Latch
43	74760612	Bolt 3/8-16 unc x 3/4
44	19133812	Washer 13/32 x 2 3/8 x 12 Ga.

NOTE: All component dimensions given in U.S. inches.
1 inch = 25.4 mm

REPAIR PARTS

TRACTOR- -MODEL NO. 917.253650

DECALS

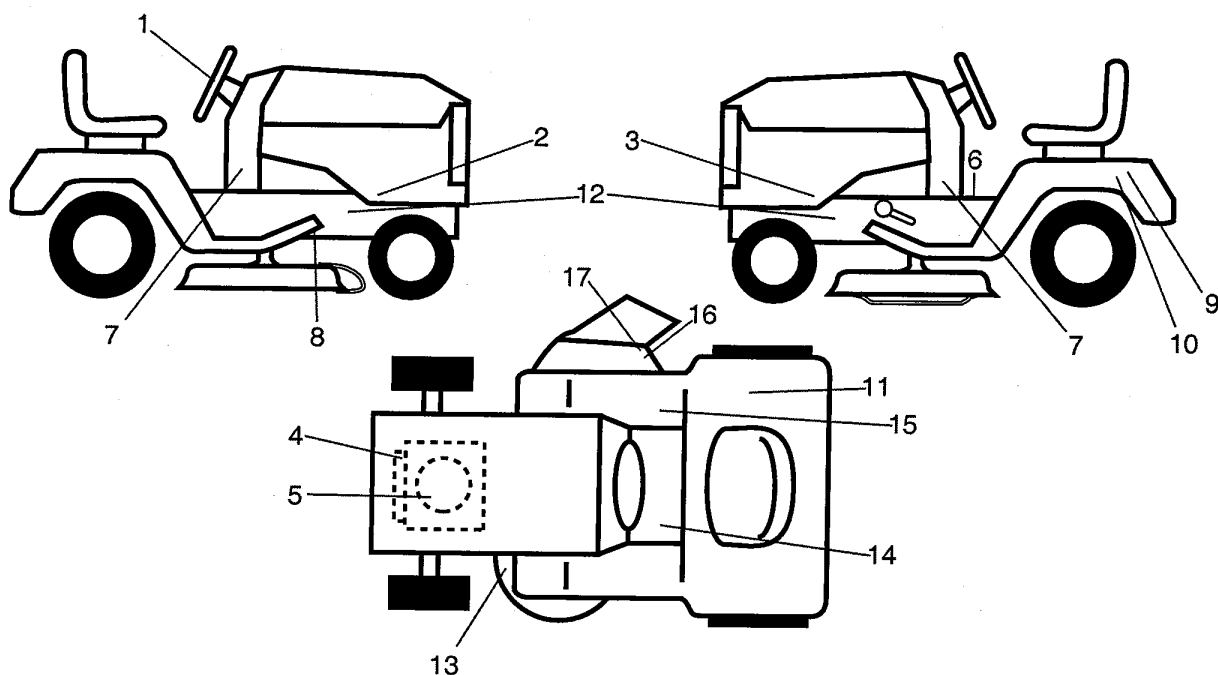

KEY NO.	PART NO.	DESCRIPTION	KEY NO.	PART NO.	DESCRIPTION
1	422885	Decal, Steering	15	140837	Decal, Saddle Brake Parking
2	426312	Decal, Panel SD LH	16	196357	Decal, Deflector Wrn. Cutfin. Sym.
3	426311	Decal, Panel SD RH	17	182166	Decal, Cuttingfnger CE
4	196841	Decal, Warning Engine Sym.	--	193226X428	Pad, Footrest LH
5	416731	Decal, Engine HP	--	193227X428	Pad, Footrest RH
6	400389	Decal, Fender Operator's	--	166960	Decal, Bypass
7	425634	Decal, Lower Dash	--	162598	Decal, Drawbar Load Limit
8	199135	Decal, V-Belt Schematic Drive	--	427344	Manual, Operator's (Euro)
9	145005	Decal, Battery Dnge/Poi	--	427346	Manual, Operator's (Scand)
10	138047	Decal, Battery	--	427347	Manual, Operator's (E-Bloc)
11	180432	Decal, Fender 100 DB/CE	--	427348	Manual, Operator's (Baltic)
12	159736	Decal, Chassis Hot Muffler	--	427339	Manual, Parts
13	160396	Decal, Mower V-Belt SCH.			
14	159737	Decal, Brake/Clutch Sym.			

WHEELS & TIRES

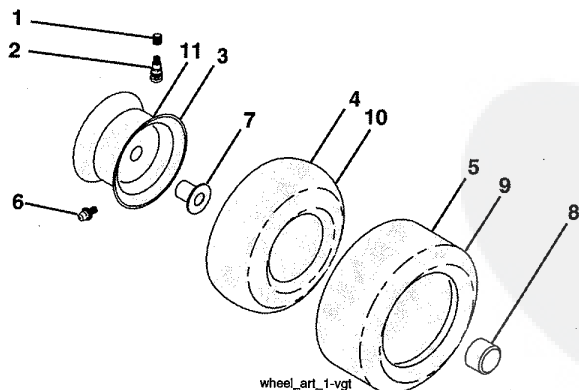

KEY NO.	PART NO.	DESCRIPTION
1	59192	Cap, Valve, Tire
2	65139	Stem, Valve
3	106732X613	Rim Assembly, Front
4	59904	Tube, Front
5	106222X	Tire, Front
6	278H	Fitting, Grease
7	9040H	Bearing, Flange
8	104757X428	Cap, Axle (Front Wheel Only)
9	420531	Tire, 18 x 9.5-8 TurfSaver LT
10	7152J	Tube, Rear
11	106108X613	Rim Assembly, Rear
--	144334	Sealant, Tire (10 oz. Tube)

NOTE: All component dimensions given in U.S. inches
1 inch = 25.4 mm

REPAIR PARTS

TRACTOR- -MODEL NO. 917.253650

ENGINE

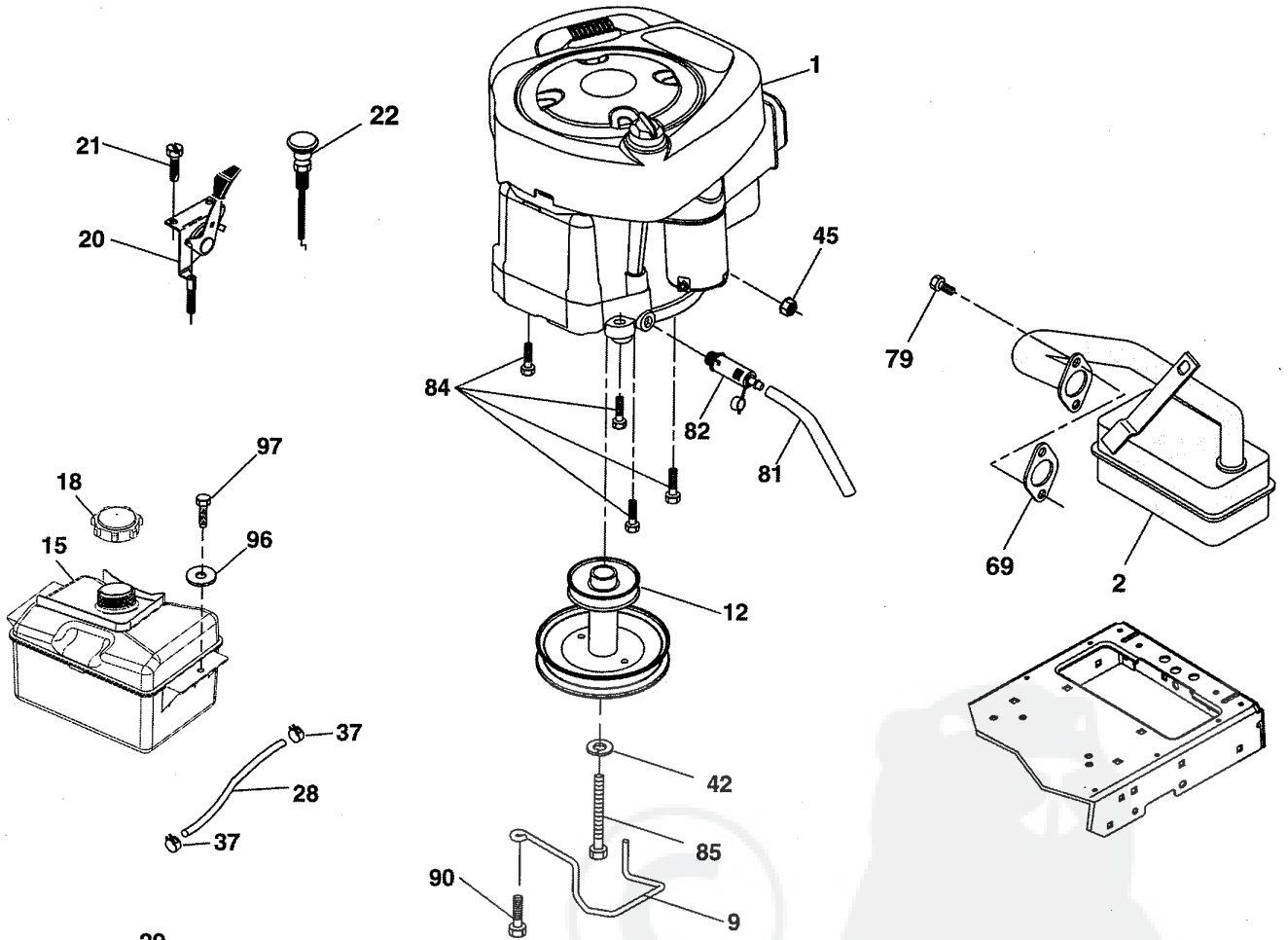

OPTIONAL EQUIPMENT
Spark Arrester

engine-tex_BS_5

REPAIR PARTS

TRACTOR- -MODEL NO. 917.253650

ENGINE

KEY NO.	PART NO.	DESCRIPTION
1	-----	Engine B&S Model No. 31C707-0240-B1
2	137352	Muffler
9	194319	Keeper Belt Engine
12	401985	Pulley Engine
15	407545	Tank Fuel 1.50
18	425162	Cap Asm
20	176636X428	Control Throttle
21	416358	Screw #10 x 0.750
22	187771X428	Control Choke
28	137040	Fuel Line
29	137180	Spark Arrester Kit
37	123487X	Clamp Hose
42	10040700	Washer Lock 7/16
45	73510400	Nut Keps Hex 1/4-20 unc
69	165291	Gasket
79	192334	Screw Socket Hd 5/16-18 x .75
81	148456	Tube Drain Oil Easy
82	181654	Plug Drain Oil
84	17060620	Screw 3/8-16 x 1-1/4
85	173937	Bolt Hex 7/16-20 x 4 x Gr. 5-1.5
90	17000616	Screw 3/8-16 x 1.0
96	19091416	Washer 9/32 x 7/8 x 16 Ga.
97	17670412	Screw 1/4-20 x 3/4

NOTE: All component dimensions given in U.S. inches
1 inch = 25.4 mm

For engine service and replacement parts, call the toll free number for your engine manufacturer listed below:

Briggs & Stratton 1-800-233-3723

Engine Power Rating Information

The gross power rating for individual gas engine models is labeled in accordance with SAE (Society of Automotive Engineers) code J11940 (Small Engine Power & Torque Rating Procedure), and rating performance has been obtained and corrected in accordance with SAE J1995 (Revision 2002-5). Actual gross engine power will be lower and is affected by, among other things, ambient operating conditions and engine-to-engine variability. Given both the wide array of products on which engines are placed and the variety of environmental issues applicable to operating the equipment, the gas engine will not develop the rated gross power when used in a given piece of power equipment (actual "on-site" or net horsepower). This difference is due to a variety of factors including, but not limited to, accessories (air cleaner, exhaust, charging, cooling, carburetor, fuel pump, etc.), application limitations, ambient operating conditions (temperature, humidity, altitude), and engine-to-engine variability. Due to manufacturing and capacity limitations, Briggs & Stratton may substitute an engine of higher rated power for this Series engine.

REPAIR PARTS

TRACTOR- -MODEL NO. 917.253650

MOWER LIFT

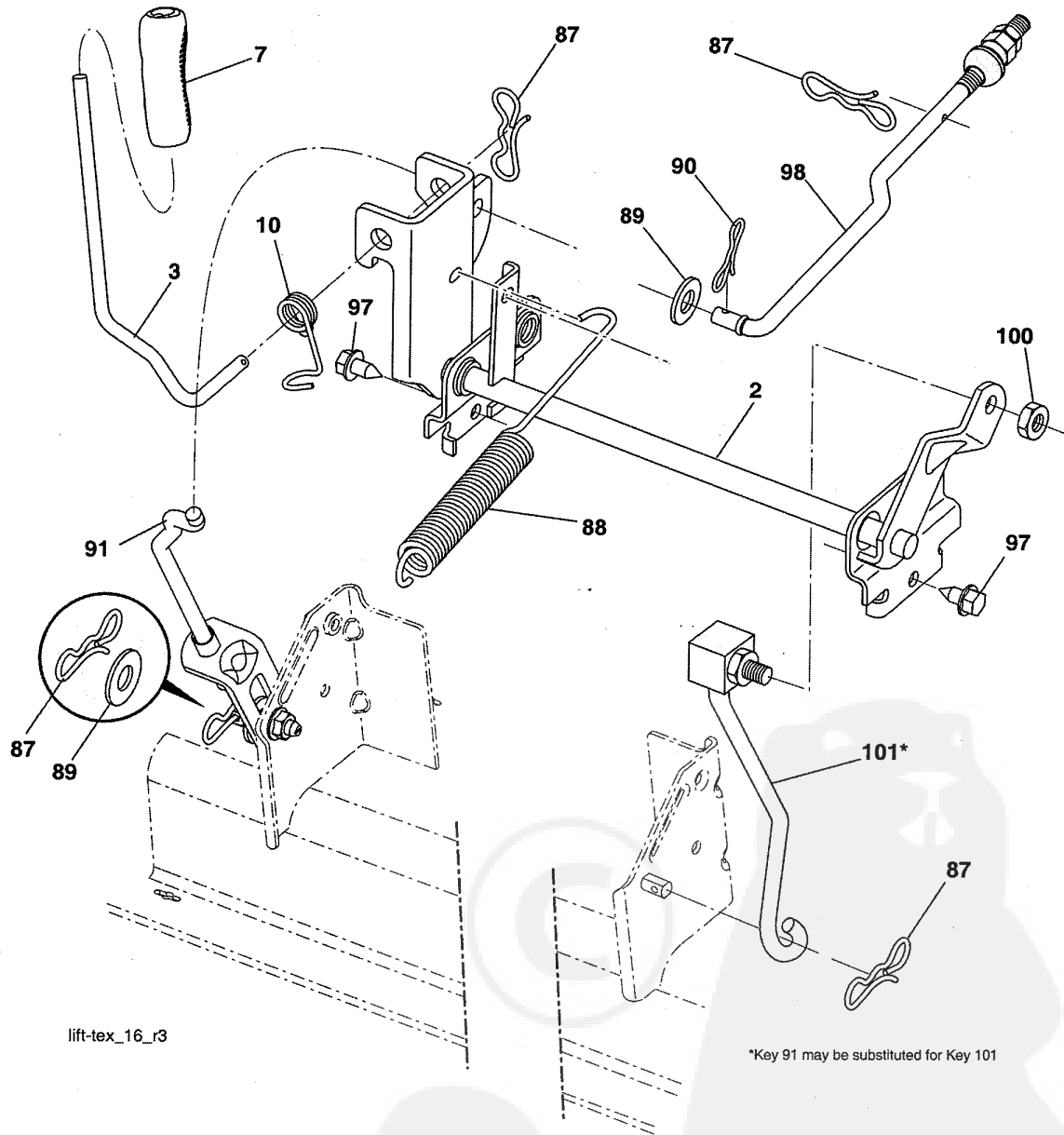

lift-tex_16_r3

*Key 91 may be substituted for Key 101

REPAIR PARTS

TRACTOR- -MODEL NO. 917.253650

MOWER LIFT

KEY NO.	PART NO.	DESCRIPTION
2	195223	Shaft Asm., Lift
3	195231	Lever Asm., Lift RH
7	196492X428	Grip, Lever
10	196314	Spring Torsion
87	194209	Pin Cotter 7/16 Bow Tie Lock
88	410710	Spring Lift Assist
89	19191912	Washer Clear Zinc
90	194208	Pin Cotter 5/16 Bow Tie Lock
91	195181	Link Lift Susp Mower Rear
97	17000612	Screw 3/8-16 x .75
98	195270	Link Lift Susp. Front Mower
100	73930600	Nut Centerlock 3/8-16 unc
101	407003	Link Asm. Lift FXD

NOTE: All component dimensions given in U.S. inches
1 inch = 25.4 mm

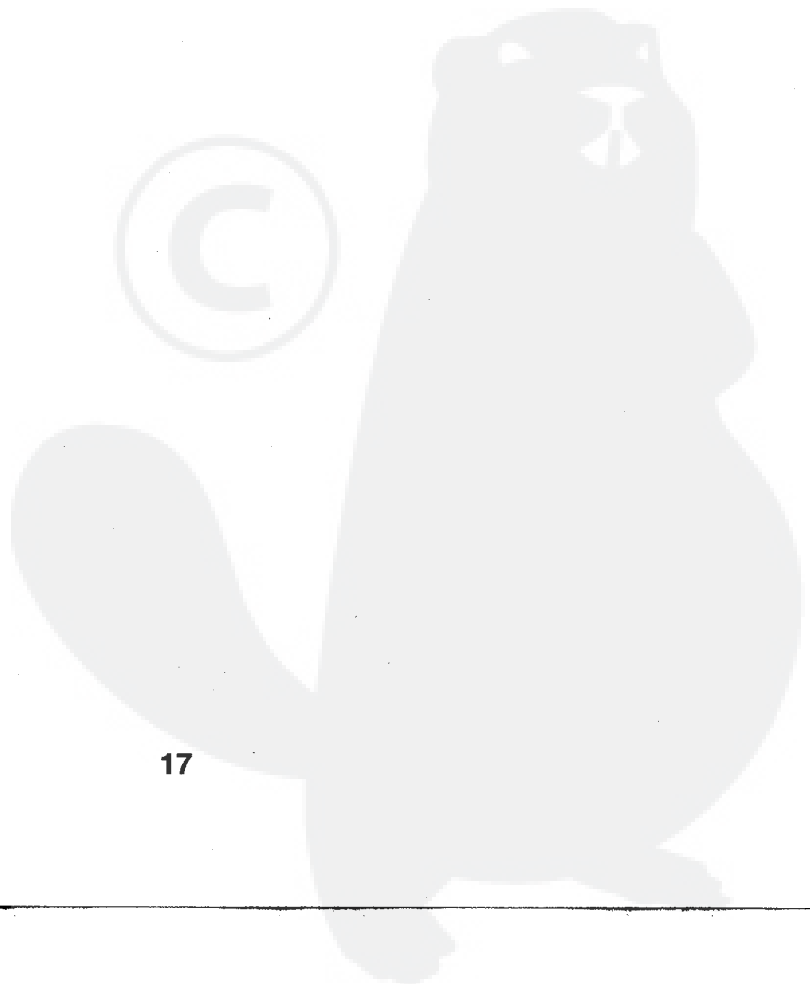
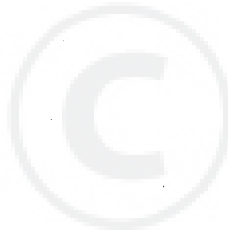

REPAIR PARTS

TRACTOR--MODEL NO. 917.253650

MOWER

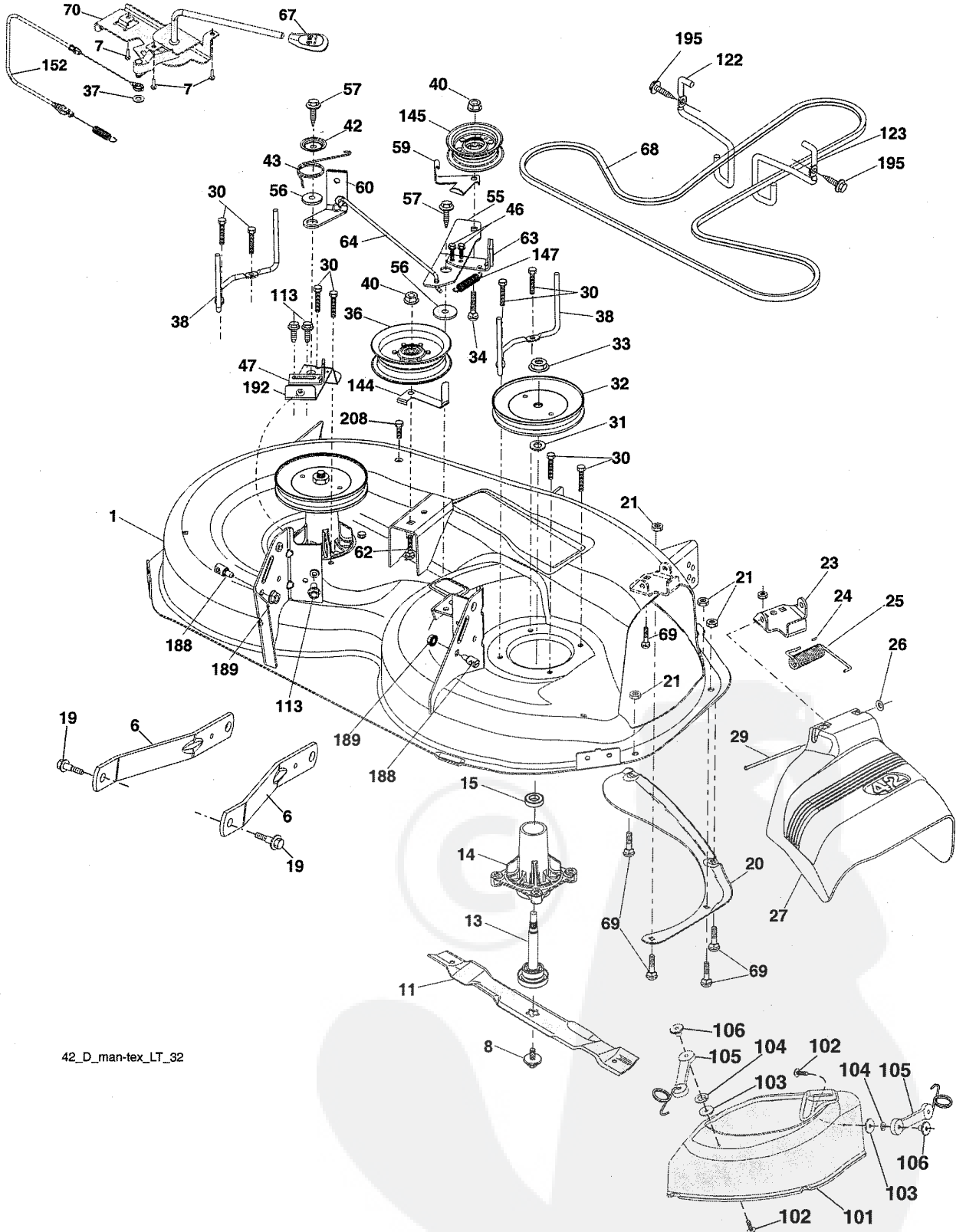

42_D_man-tex_LT_32

REPAIR PARTS

TRACTOR- -MODEL NO. 917.253650

MOWER

KEY NO.	PART NO.	DESCRIPTION	KEY NO.	PART NO.	DESCRIPTION
1	199911	Mower Housing	62	72110616	Bolt Rdhd Sqnk 3/8-16 unc x 2
6	195186	Arm Suspension	63	199477	Arm Brake Mower
7	416358	Screw 10 x .750 BOS Thread	64	199790	Linkage Brake
8	193003	Bolt/Washer Asm 7/16-20 unf	67	198398X428	Handle, Clutch Cable
11	424752	Blade, 3N1	68	197253	V-Belt
13	192872	Shaft Assembly, Mandrel	69	72140505	Bolt Rdhd Sqnk 5/16-18 x 5/8
14	187281	Housing, Mandrel	70	401246	Clutch Asm. Manual
15	110485X	Bearing, Ball, Mandrel	101	193107	Cover Mulching
19	196539	Bolt, Shoulder	102	71081010	Screw Pan Hd. Phillip 10-24 x 5/8
20	159770	Baffle Vortex	103	19061216	Washer #10
21	73680500	Nut, Crownlock 5/16-18 unc	104	10071000	Washer Lock #10
23	192557	Bracket, Deflector	105	160793	Latch Asm.
24	105304X	Cap, Sleeve	106	2029J	Nut Weld 327/304 #10-24
25	197026	Spring, Torsion, Deflector	113	17000510	Screw 5/16-18
26	110452X	Nut, Push	122	197258	Keeper Belt Eng. LH
27	424469	Shield, Deflector	123	197259	Keeper Belt Eng. RH
29	131491	Rod, Hinge	144	199204	Keeper Belt
30	173984	Screw Thdrol Rolling Wsh Hd	145	193197	Pulley, Idler, Flat
31	187690	Washer, Spacer	147	401971	Spring Return
32	197473	Pulley, Mandrel	152	408714	Cable Clutch Manual w/Spr.
33	400234	Nut, Toplock, Flanged	188	195161	Stud Fastener
34	72110612	Bolt Carr Sh. 3/8-16 x 1-1/2 Gr. 5	189	73900500	Nut Lock Hex Flange
36	197379	Pulley Idler	192	197260	Bracket Brake Stand LH
37	19131316	Washer 13/32 x 13/16 x 16 Ga.	195	17000612	Screw Hexwsh Thdr 3/8-16 x 3/4
38	199189	Keeper Belt LH Mandrel	208	17670608	Screw 3/8-16 x 1/2
40	73900600	Nut, Lock Fig. 3/8-16 unc	--	426340	Replacement Mower, Complete
42	197256	Spring Torsion Retainer	--	192870	Mandrel Assembly (Mandrel As- sembly (Includes housing, shaft assembly, and bearing only - pulley/ nut/washer and blade bolt/washers not included)
43	198410	Spring Torsion Brake			
46	137729	Screw Thd Roll 1/4-20 x 5/8			
47	197250	Bracket Clutch Cable			
55	197249	Arm, Idler			
56	199092	Spacer, Retainer			
57	17000616	Screw Hexwsh Thd 3/8-16 x 1			
59	141043	Guard, Tuv Idler (94)			
60	197261	Arm Brake Mower			

NOTE: All component dimensions given in U.S. inches
1 inch = 25.4 mm

TRACTOR -- MODEL NUMBER 917.253650
HYDRO GEAR TRANSAXLE - MODEL NUMBER T2

T2-AABC-1X1A-1GX1

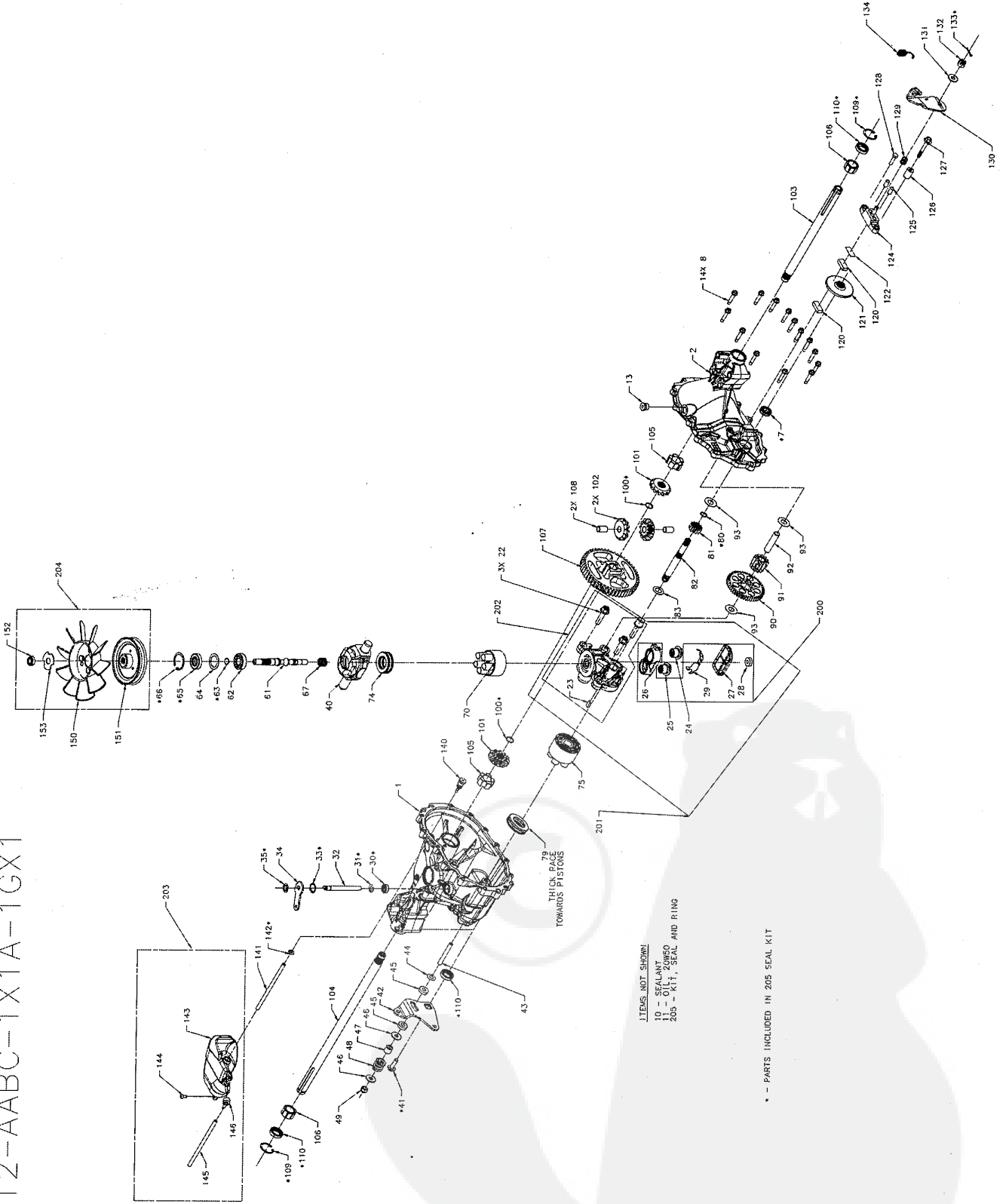

TRACTOR - - MODEL NUMBER 917.253650

HYDRO GEAR TRANSAXLE - MODEL NUMBER T2

KEY NO.	PART NO.	DESCRIPTION	KEY NO.	PART NO.	DESCRIPTION
1	412015	Kit, Hsg, Main	93	170418	Washer.51x1.10x.03
2	412016	Kit, Hsg, Side	100	170393	Ring, Ret - Spiral .625 Ext
7	422987	Seal, Lip .50x1.0x.25 Tc	101	401260	Gear, Bevel 12t Splline Id
8	170356	Hfhcs 1/4-20 X 1 .25"	102	401261	Gear, Bevel 12t .50 Id
10	178322	Sealant	103	170391	Shaft, Axle, Keyed, 11.39 X 0.75
11	N/A	Oil, 20w50	104	170392	Shaft, Axle, Keyed, 16.99 X 0.75
13	170434	Plug 9/16-18 (Metal)	105	412052	Bushing, Inboard
22	412022	Bolt, Hex Flange. 3/8-16, C/S	106	412053	Bushing, Outboard
23	412023	Plate, Bypass	107	412054	Gear, 53t Bull
24	170420	Assembly, Check Plug W/ Washer. .027	108	421055	Pin. Differential
25	412024	Assembly, Check Plug W/ Washer, .027, Spring	109	412056	Ring, Ret, Int Axle
26	412025	Base, Filter	110	142961	Seal, Lip.75x1.125x.25 Tc
27	412026	Cover, Filter	120	142883	Puck, Brake
28	170395	Ring, Magnet	121	412057	Rotor, Brake
29	412027	Deflector	122	142882	Plate, Puck
30	412028	Seal, Lip.375x.75x.25 Tc	124	142929	Yoke, Brake
31	412029	Ring, Ret .375 Ext	125	142887	Pin. Brk .31x.73 Plated
32	412030	RoD, Actuator Bypass	126	161174	Spacer .26x.57x.87
33	412031	Ring, Ret .750 Int	127	170410	Hfhcs 1/4-20 X 2.0 W/Patch
34	412032	Arm. Bypass	128	142892	Hhcs 1/4-20x1 (Patch)
35	412033	Ring, Ret .375 Ext	129	161181	Spring. Comp Brake Anti-Drag
40	412034	Trunnion. Swash Plate	130	142954	Arm, Brake
41	412035	Screw 5/16-18x1	131	142884	Washer .34x.88x.06
42	412036	Arm, Cntrl	132	142885	Nut, Castle 5/16-24 PI
43	412037	Screw. Set 3/16-24 X 2.50	133	142886	Pin, Cotter 3/32x3/4
44	412038	Washer, Belleville	134	189386	Spring, Brake Arm Bias
45	412039	Washer,Plastic, .32x.80x.21	140	170425	5/16 Sae, 5/32 Tube
46	142884	Washer .34x.88x.06	141	412058	Hose
47	142980	Spacer .32x.59x.50	142	170435	O-Ring .103x.299 Id
48	142969	Spring, Helical Comp	143	412059	Tank. Expansion
49	150778	Nut, Hex 5/16-24 Nylon Lnsert	144	422988	Bolt, Self-Tapping 10-32x1/2
61	412040	Shaft, Linput	145	412058	Hose
62	142934	Ball Bear L Ng 15x35x 1 1	146	401264	Cap, Barbed Vent
63	142928	Ring, Ret Wire .512 Id	150	170439	Fan, 7', 10 Blade
64	161125	Washer 1.23x1.56x.04	151	412061	Pulley, Flanged, 4.13"
65	142932	Seal, Lip 15x35x7	152	170441	Nut, Hex Lock, 1/2-20 (Nylon Insert)
66	142933	Ring, Ret 1.56 Int	153	170442	Washer,Odslotted .53x1.63x.06
67	412041	Spring. Helical	200	412062	Kit, Filter
70	412042	Kit, Block, Cyl 8cc	201	412063	Kit, Center Section W/Filter
74	412043	Brg, Thrust Ball 27x47x14	202	412064	Kit, Center Section
75	169898	Kit, Block, Cyl 10cc Rm	203	412065	Kit, Tank Expansion
79	150771	Brg, Thrust Ball 30x52x13	204	412066	Kit, Fan & Pulley
80	412044	Ring, Ret .50 Ext	205	412067	Kit, Seal
81	412045	Gear. 13t Pinion			
82	412046	Shaft, Motor			
83	412047	Washer .60x1.00x.03			
90	412048	Gear, 11t/48t			
91	412049	Gear, Jackshaft 11t			
92	412050	Jack Shaft (P1n)			

NOTE: All component dimensions given in U.S. inches
1 inch = 25.4 mm

REPAIR PARTS

TRACTOR- -MODEL NO. 917.253650

BRIGGS & STRATTON ENGINE - - MODEL NUMBER 31C707, TYPE NUMBER 0240-B1

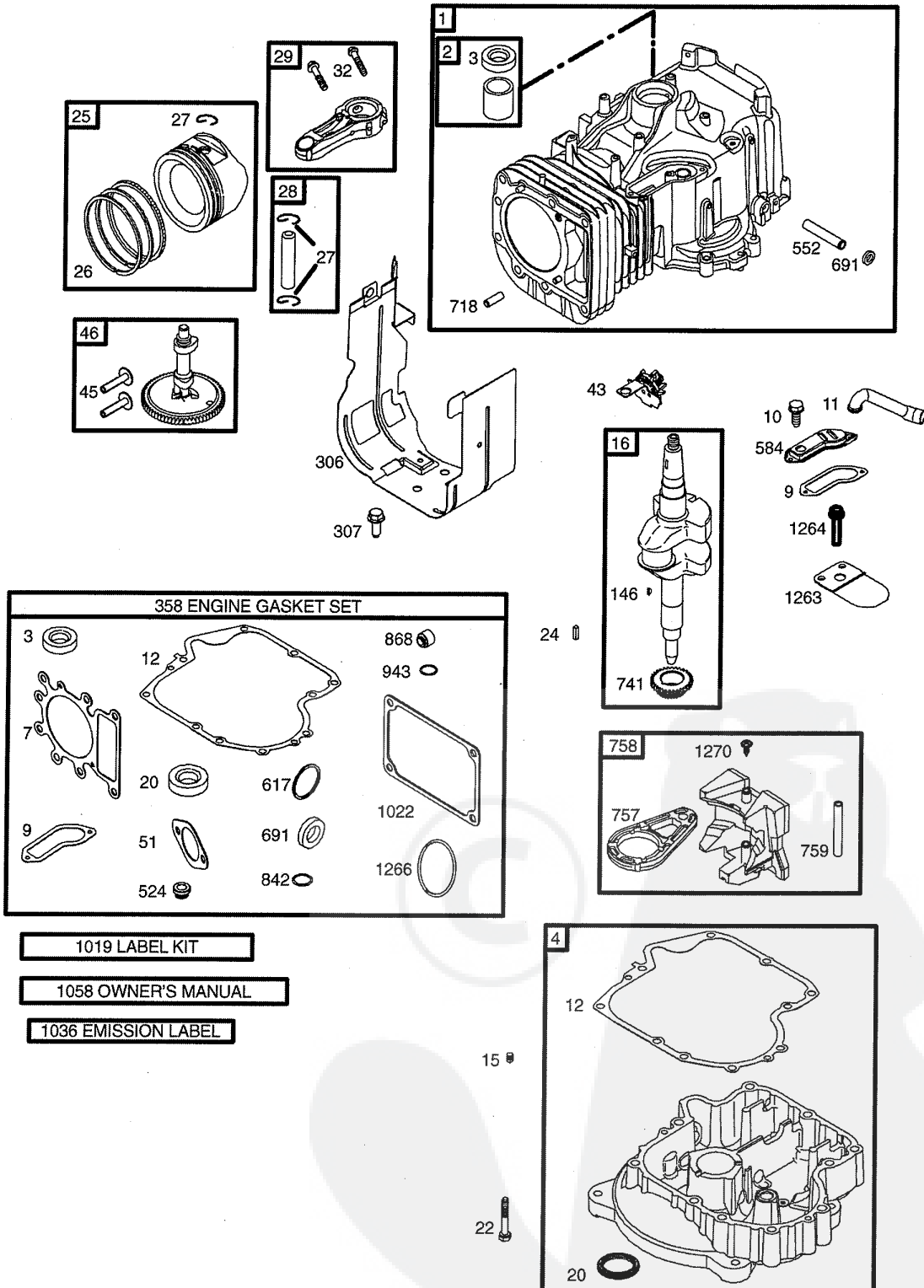

REPAIR PARTS

TRACTOR- -MODEL NO. 917.253650

BRIGGS & STRATTON ENGINE - - MODEL NUMBER 31C707, TYPE NUMBER 0240-B1

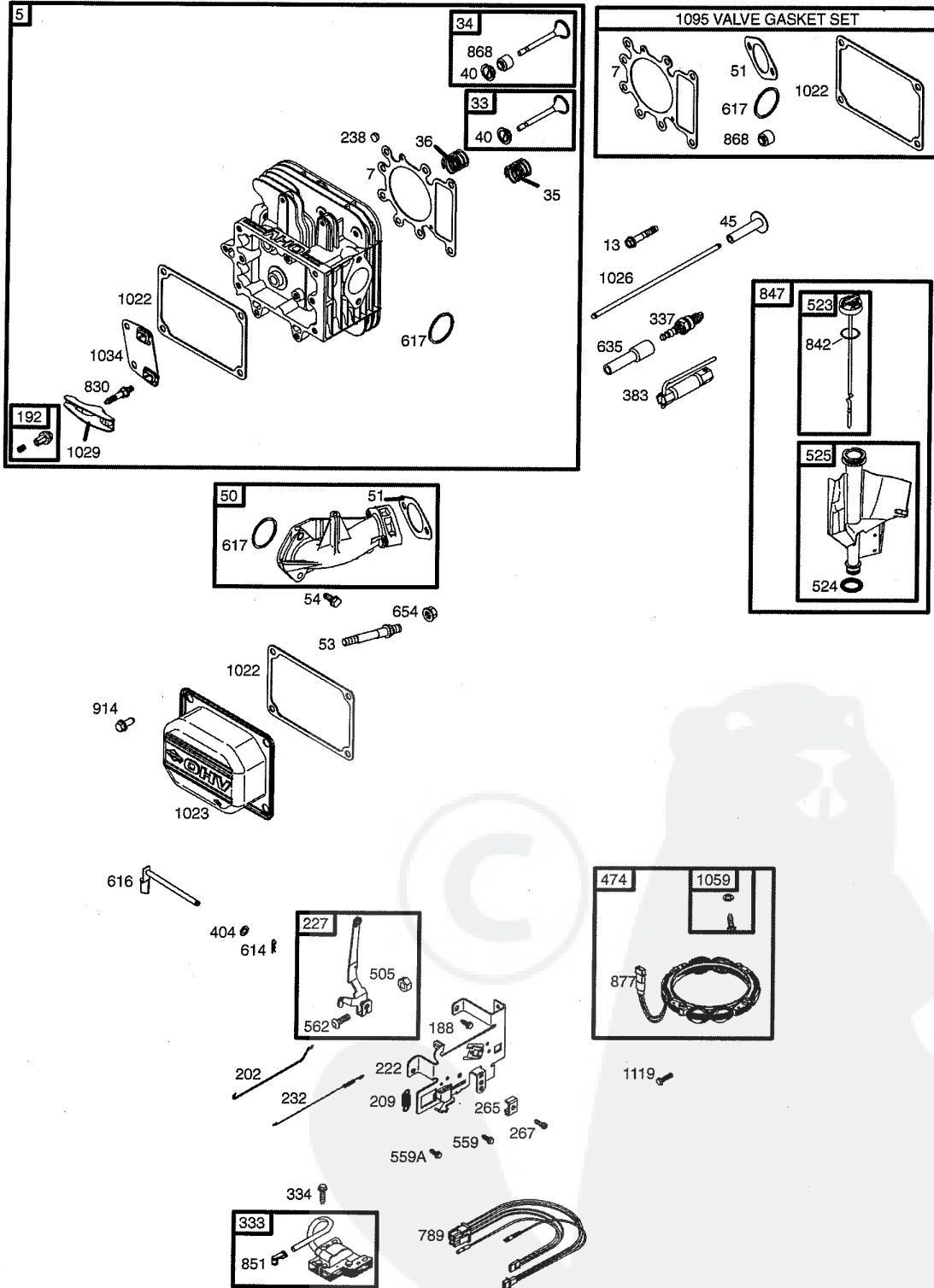

REPAIR PARTS

TRACTOR - - MODEL NO. 917.253650

BRIGGS & STRATTON ENGINE - - MODEL NUMBER 31C707, TYPE NUMBER 0240-B1

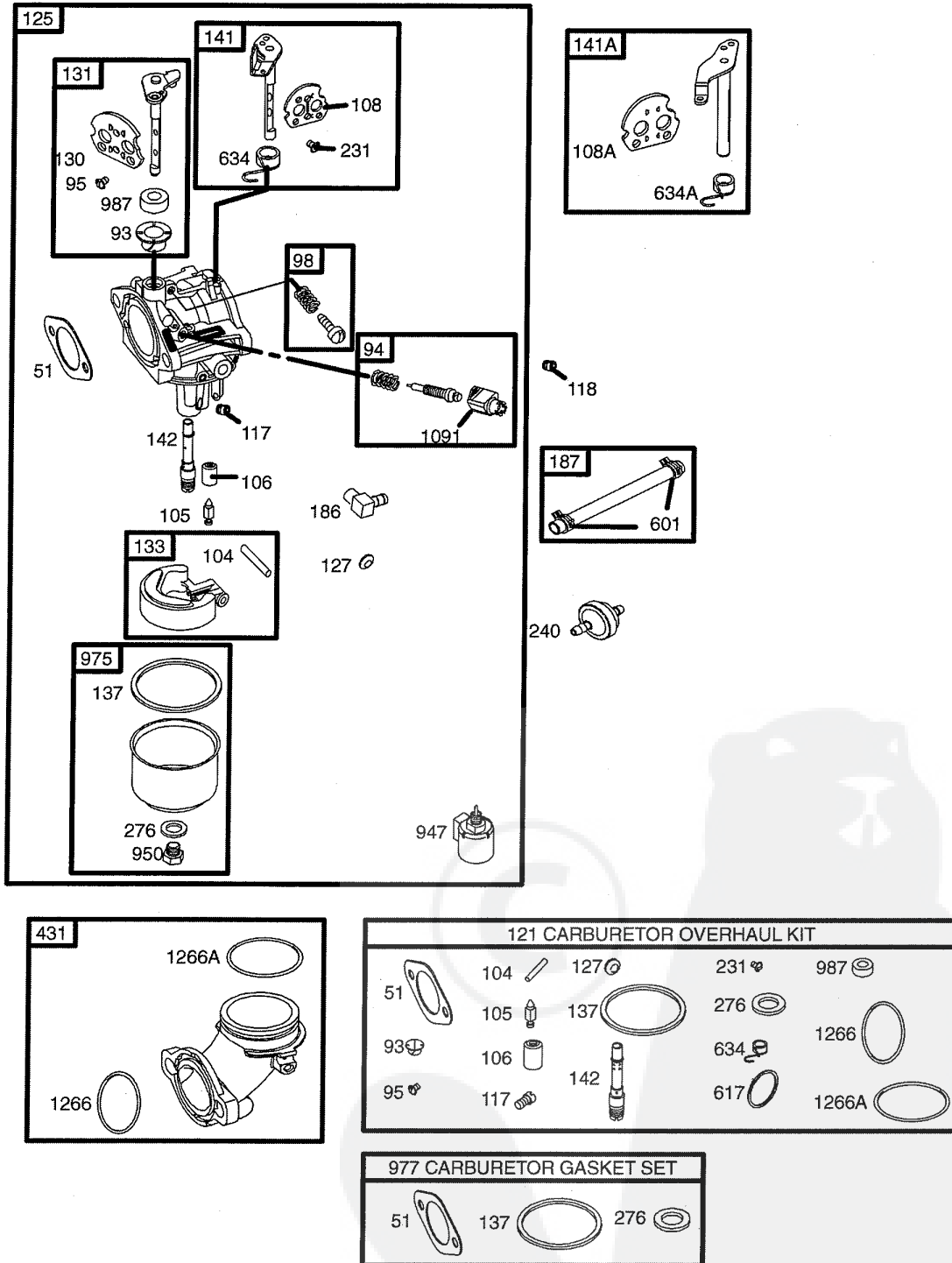

REPAIR PARTS

TRACTOR- -MODEL NO. 917.253650

BRIGGS & STRATTON ENGINE - - MODEL NUMBER 31C707, TYPE NUMBER 0240-B1

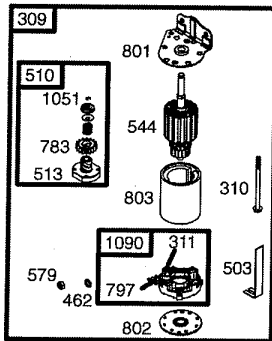
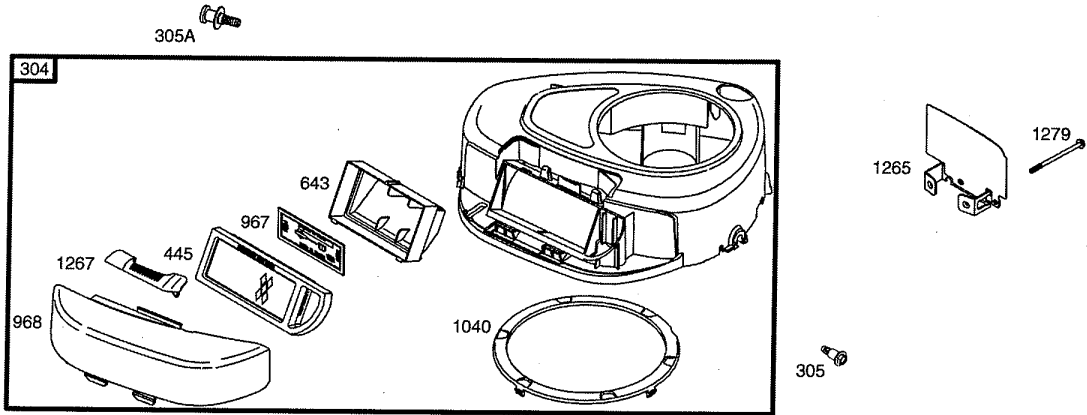

729 (screw)
697 (screw)

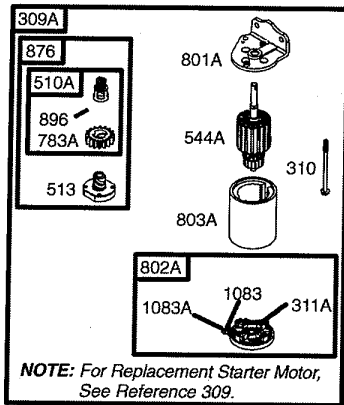
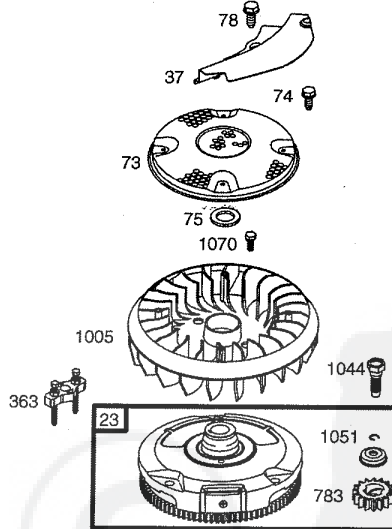

NOTE: For Replacement Starter Motor, See Reference 309.

REPAIR PARTS

TRACTOR- -MODEL NO. 917.253650

BRIGGS & STRATTON ENGINE - - MODEL NUMBER 31C707, TYPE NUMBER 0240-B1

KEY NO.	PART NO.	DESCRIPTION	KEY NO.	PART NO.	DESCRIPTION
1	697174	Cylinder Assembly	98	495800	Kit-Idle Speed
2	399265	Kit-Bushing/Seal (Magneto Side)	104	690525	∅ Pin-Float Hinge
3	391086	• Seal-Oil (Magneto Side)	105	231855	∅ Valve-Float Needle
4	697106	Sump-Engine	106	690577	∅ Seat-Inlet
5	698147	Head-Cylinder	108	690464	Valve-Choke (Manual Choke)
7	692410	*+ Gasket-Cylinder Head	108A	692344	Valve-Choke (Choke A Matic)
9	697109	• Gasket-Breather	117	694352	∅ Jet-Main (Standard)
10	697157	Screw (Breather Assembly)	118	697492	Jet-Main (High Altitude)
11	697113	Tube-Breather	121	697241	Kit-Carburetor Overhaul
12	697110	• Gasket-Crankcase	125	697190	Carburetor
13	690360	Screw (Cylinder Head)	127	695005	Plug-Welch
15	690946	Plug-Oil Drain	130	691750	Valve-Throttle
16	697127	Crankshaft	131	494379	Kit-Throttle Shaft
20	690947	• Seal-Oil (PTO Side)	133	494381	Float-Carburetor
22	692125	Screw (Crankcase Cover/Sump)	137	281165	∅‡ Gasket-Float Bowl
23	693557	Flywheel	141	495097	∅‡ Kit-Choke Shaft (Manual Choke)
24	222698	Key-Flywheel	141A	495931	∅‡ Kit-Choke Shaft (Choke A Matic)
25	697159	Piston Assembly (Standard)	142	697140	∅ Nozzle-Carburetor
	697160	Piston Assembly (.010" Oversize)	146	691639	Key-Timing
	697162	Piston Assembly (.020" Oversize)	186	692317	Connector-Hose
	697163	Piston Assembly (.030" Oversize)	187	691050	Line-Fuel (Cutto Required Length)
26	697164	Ring Set (Standard)	188	691693	Screw (Control Bracket)
	697165	Ring Set (.010" Oversize)	192	691986	Adjuster-Rocker Arm
	697171	Ring Set (.020" Oversize)	202	691841	Link-Mechanical Governor
	697172	Ring Set (.030" Oversize)	209	692208	Spring-Governor
27	697100	Lock-Piston Pin	222	694042	Bracket-Control
28	697099	Pin-Piston	227	691374	Lever-Governor Control
29	697126	Rod-Connecting (Standard)	231	691636	Screw (Choke Valve)
32	692852	Screw (Connecting Rod)	232	691842	Spring-Governor
33	495856	Valve-Exhaust	238	691843	Cap-Valve
34	495857	Valve-Intake	240	394358	Filter-Fuel
35	691279	Spring-Valve (Intake)	265	691024	Clamp-Casing
36	691279	Spring-Valve (Exhaust)	267	695134	Screw (Casing Clamp)
37	697352	Guard-Flywheel	276	692255	∅‡ Washer-Sealing
40	691752	Retainer-Valve	304	698402	∅‡ Housing-Blower
43	691968	Slinger-Governor/Oil	305	697102	Screw (Blower Housing)
45	690564	Tappet-Valve	305A	697103	Screw (Blower Housing)
46	697687	Camshaft	306	697107	Shield-Cylinder
48	697761	Short Block (31C707-0240-E2 Replacement)	307	691003	Screw (Cylinder Shield)
		Engine-art not available)	309	693551	Motor-Starter
50	690193	Manifold-Intake	309A	-----	Motor-Starter (For Replacement Starter Motor, See Reference 309)
51	692137	*∅‡+ Gasket-Intake	310	690323	Bolt (Starter Motor)
53	690227	Stud (Carburetor)	311	497608	Brush Set
54	691148	Screw (Intake Manifold)	311A	395538	Brush Set
73	697384	Screen-Rotating	333	492341	Armature-Magneto
74	697987	Screw (Rotating Screen)	334	691061	Screw (Magneto Armature)
75	690582	Washer (Flywheel)	337	691043	Plug-Spark
78	691003	Screw (Flywheel Guard)	358	697191	Gasket Set-Engine
93	690602	∅ Bushing-Throttle Shaft	363	19203	Flywheel Puller
94	498030	Kit-Idle Mixture	383	89838	Wrench-Spark Plug
95	691636	Screw (Throttle Valve)	404	691691	Washer (Governor Crank)
			431	697122	Elbow-Intake

GENERAL: Craftsman products are warranted to be free from defects in materials or workmanship for a specific time period as set-out below (the "Warranty Period"). Warranties extend to the original purchaser of a Craftsman product only. Purchases made through an online auction or through any website other than www.sears.ca are excluded. The relevant Warranty Period commences on the original date of purchase. Within this period, SEARS CANADA, Inc. will, at its sole option, repair or replace any products or components which fail in normal use. Such repairs or replacement will be made at no charge to the customer for parts or labor, provided that the customer shall be responsible for any transportation cost.

EXCLUSIONS: This warranty does not cover failures due to normal wear, abuse, misuse, neglect (including but not limited to the use of stale fuel, dirt, abrasives, moisture, rust, corrosion, or any adverse reaction due to improper storage or use habits), improper maintenance or failure to follow maintenance guidelines and/or instructions, failure to operate the product in accordance with the owner's manual or any additional instructions or information provided at the time of purchase or in subsequent communications with the original purchaser, accident or unauthorized alterations or repairs made or attempted by others. Also excluded from warranty coverage - except as provided below - are the following: maintenance, adjustments, components subject to wear including but not limited to: cosmetic components, belts, blades, blade adapters, bulbs, tires, filters, guide bars, lubricants, seats, grips, recoil assy's, saw chains and bars, trimmer lines and spools, spark plugs, starter ropes and tines, and discoloration resulting from ultraviolet light. Any product missing the model and/or serial number identification label will be disqualified from coverage under this warranty.

REPAIRS: Repairs have a 90 day warranty. If the defective product is still within the Warranty Period, then the new warranty is 90 days from the date of repair or to the end of the original Warranty Period, whichever period is longer.

DISCLAIMERS: THE WARRANTIES AND REMEDIES CONTAINED HEREIN ARE EXCLUSIVE AND IN LIEU OF ALL OTHER WARRANTIES, WHETHER ORAL OR WRITTEN (OTHER THAN AS STATED HEREIN), AND WHETHER EXPRESS, IMPLIED OR STATUTORY, INCLUDING BUT NOT LIMITED TO ANY. THIS WARRANTY GIVES YOU SPECIFIC LEGAL RIGHTS, WHICH MAY VARY FROM PROVINCE TO PROVINCE.

IN NO EVENT SHALL SEARS BE LIABLE FOR ANY INCIDENTAL, SPECIAL, INDIRECT OR CONSEQUENTIAL DAMAGES, WHETHER RESULTING FROM THE USE, MISUSE OR INABILITY TO USE THE PRODUCT OR FROM DEFECTS IN THE PRODUCT. THE EXCLUSIONS IN THIS PARAGRAPH SHALL NOT APPLY IN JURISDICTIONS WHERE APPLICABLE LAW DOES NOT ALLOW FOR THE EXCLUSION OF INCIDENTAL OR CONSEQUENTIAL DAMAGES. IN SUCH JURISDICTIONS, THIS PARAGRAPH SHALL NOT APPLY, BUT THE REMAINING PROVISIONS OF THIS DOCUMENT SHALL REMAIN VALID.

SEARS retains the exclusive right to repair or replace the product or offer a full refund of the purchase price at its sole discretion. SUCH REMEDY SHALL BE YOUR SOLE AND EXCLUSIVE REMEDY FOR ANY BREACH OF WARRANTY.

CUSTOMER RESPONSIBILITIES: In addition to complying with all suggested maintenance guidelines and instructions, customers' obligations shall include but shall not be limited to: operating the product in accordance with the owner's manual or any additional instructions or information provided at the time of purchase or in subsequent communications to the purchaser from time to time, exhibit reasonable care in the use, operation, maintenance, general upkeep and storage of the product. Failure to comply with these requirements will void any applicable warranty.

LIST OF APPLICABLE WARRANTY PERIODS: The following list contains the applicable Warranty Period for your Craftsman product and is based on a combination of the type of product or component and the intended and actual use of the product or component:

1. **90 DAYS:** Craftsman products intended for use or actually used for commercial, institutional, professional or income-producing purposes
2. **2 YEARS:** Craftsman riding lawn mowers, yard and garden tractors, walk behind mowers, tillers, brush cutters, snow blowers, handheld blowers, backpack blowers, hedge trimmers and electrical products for noncommercial, nonprofessional, non-institutional, or non-income-producing use, except for those components which are part of engine systems manufactured by third party engine manufacturers for which the purchase has received a separate warranty with product information supplied at the time of purchase.
3. **1 YEAR:** Craftsman power cutters, stump grinders, pole pruners, gas chain saws, electric chain saws, trimmer attachments, baggers and pole saws for noncommercial, nonprofessional, non-institutional, or non-income-producing use.
4. **90 DAYS:** All defective batteries, which will be replaced during this 90-day Warranty Period.
5. **60 DAYS:** Additional Warranty Period of 60 days will apply to adjustments and worn products or components BUT DOES NOT INCLUDE WEAR OR ADJUSTMENTS for products used for commercial, institutional, professional or income-producing purposes. Wear items include but are not limited to: belts, blades, tires, spark plugs, air filters, chains, shear bolts, skid plates, scraper bars, drift cutters, ropes, tines, collection bags and pulleys.

As the Warranty Period runs from the date of purchase and NOT from the date that a product is delivered, opened, assembled or first used, please ensure during this time period that your product or component has been assembled and tested for correction operation regardless of when you intend to actually use it. Claims made after the Warranty Period has expired will not be honored.

PROOF OF PURCHASE/DOCUMENTATION: Warranty coverage is conditioned upon the original purchaser furnishing SEARS CANADA or its authorized third party service provider if applicable, with the original sales receipt or other adequate written proof of the original purchase date and identification of the product. In the event that the original purchaser is unable to provide a company of the original sales receipt, SEARS CANADA Inc. reserves the right to determine in its sole discretion what other written proof of the original purchase date and identification of the product is acceptable.

CRAFTSMAN®