

REPAIR PARTS MANUAL
MODEL NO. 277480
Lawn Tractor

CRAFTSMAN[®]

HOW TO USE THIS MANUAL

This manual is designed to provide the customer with a means to identify the parts on his/her tractor when ordering repair parts. The illustrations may or may not represent the actual assemblies; therefore, it is not recommended to use this manual as a guide to assemble or disassemble the tractor. Some hardware and parts are drawn larger in order to more readily identify them.

Each tractor has its own model number.

The model number for your tractor can be found on the fender under the seat.

When ordering parts, always give the following information:

- Product - "Tractor"
- Model Number - 277480
- Part Number
- Part Description

TABLE OF CONTENTS

SCHEMATIC	3
ELECTRICAL.....	4-5
CHASSIS AND ENCLOSURES.....	6-7
DRIVE.....	8-9
STEERING ASSEMBLY.....	10-11
SEAT ASSEMBLY.....	12
DECALS.....	13
ENGINE.....	14-15
MOWER LIFT	16-17
MOWER	18-19
TRANSAXLE.....	20-21
ENGINE BREAKDOWN.....	22-26
WARRANTY	27

TRACTOR- -MODEL NO. 917.277480

SCHEMATIC

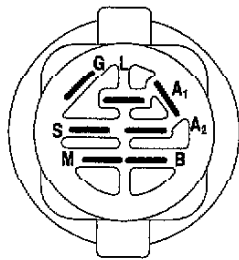
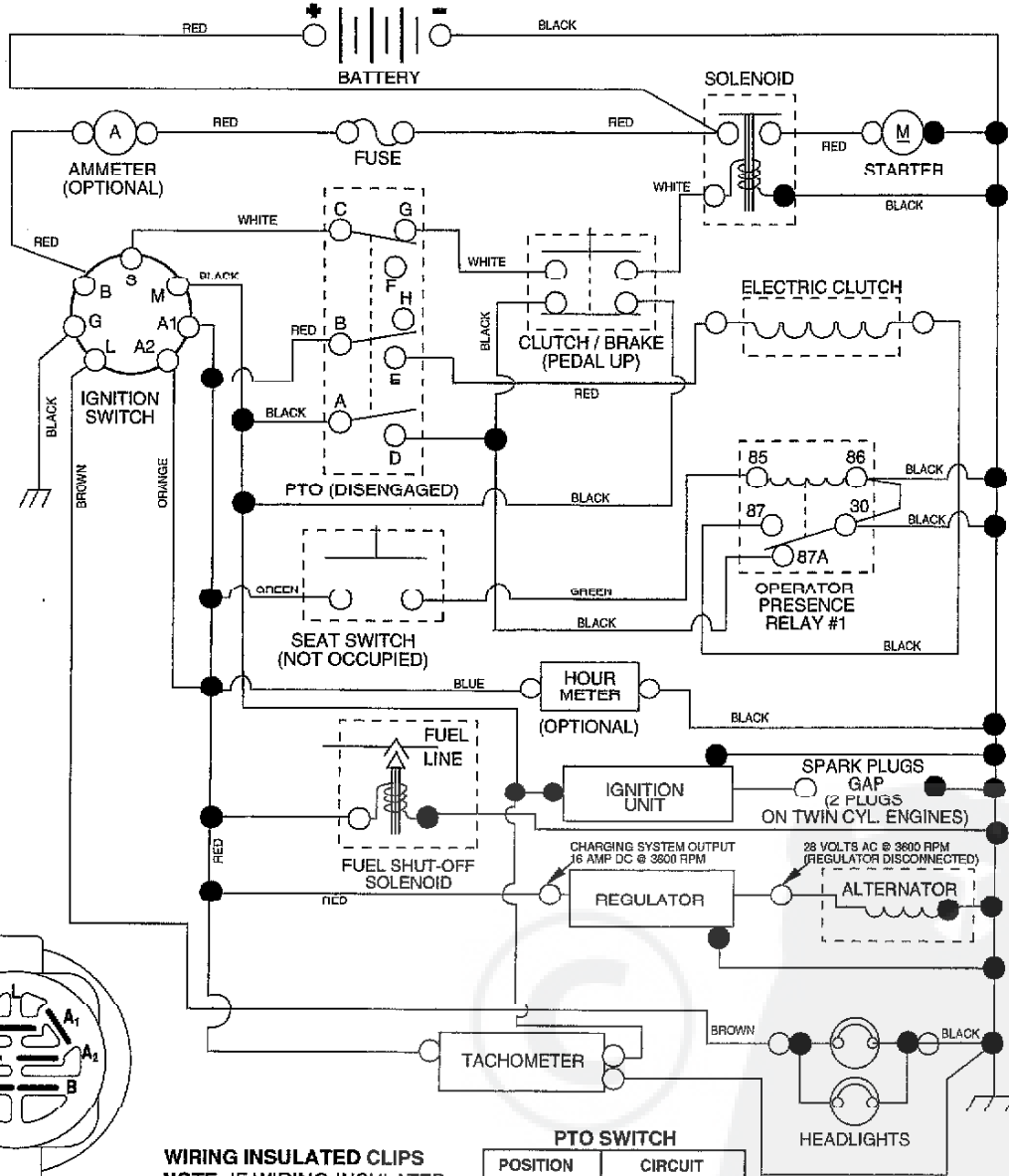

IGNITION SWITCH

POSITION	CIRCUIT	"MAKE"
OFF	M + G + A1	NONE
ON + LIGHTS	B + A1	L + A2
ON	B + A1	NONE
START	B + S + A1	NONE

WIRING INSULATED CLIPS
NOTE: IF WIRING INSULATED CLIPS WERE REMOVED FOR SERVICING OF UNIT, THEY SHOULD BE REPLACED TO PROPERLY SECURE YOUR WIRING.

02712

PTO SWITCH

POSITION	CIRCUIT
OFF	C + G, B + H
ON	C + F, B + E, A + D

○ REMOVABLE CONNECTIONS

● NON-REMOVABLE CONNECTIONS

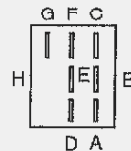

REPAIR PARTS

TRACTOR- -MODEL NO. 917.277480

ELECTRICAL

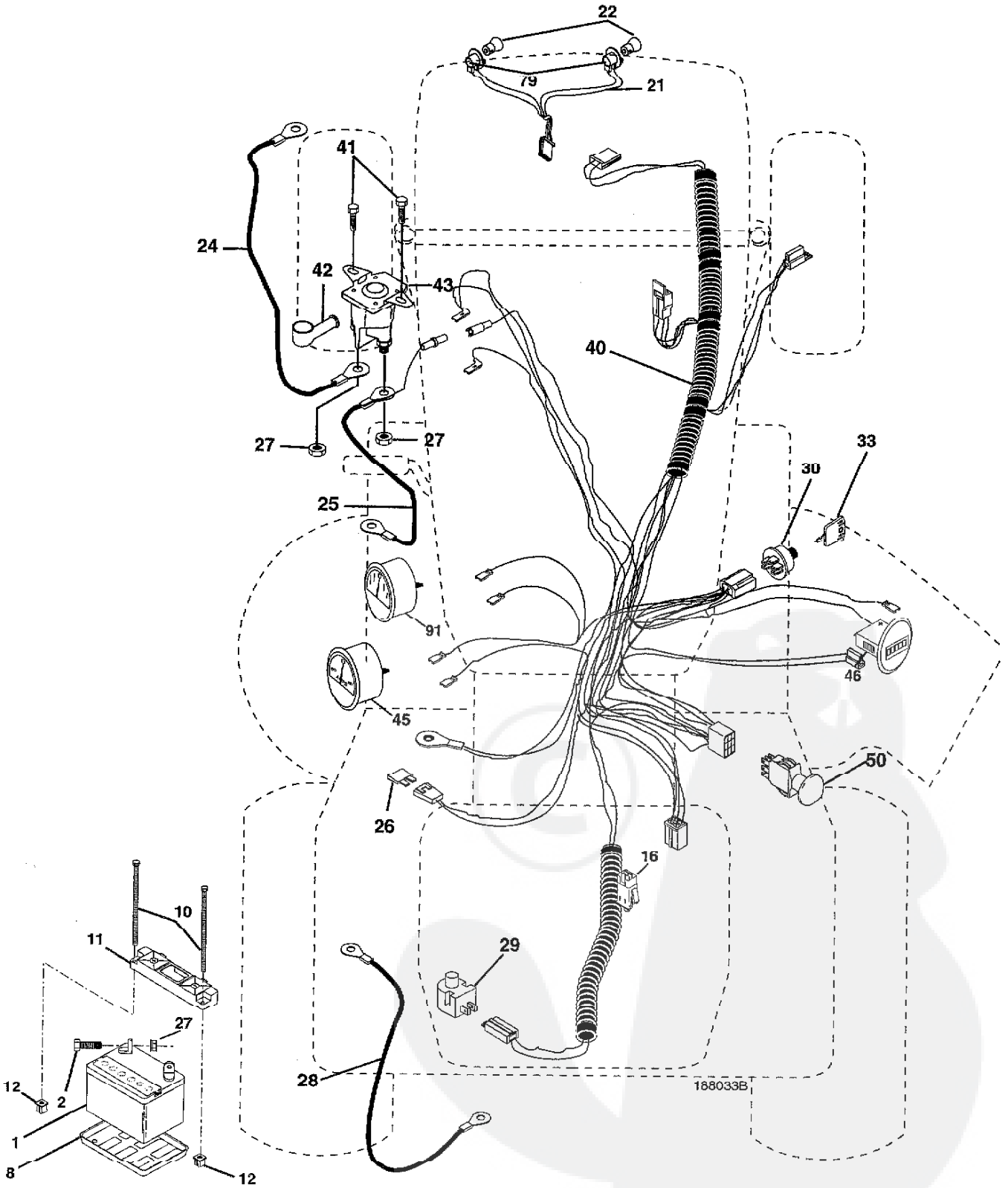

REPAIR PARTS

TRACTOR- -MODEL NO. 917.277480

ELECTRICAL

KEY NO.	PART NO.	DESCRIPTION
1	144927	Battery
2	74760412	Bolt Hex Head 1/4-20 x 3/4
8	7603J	Tray, Battery
10	145211	Bolt 1/4-20 x 7.5 Zinc
11	150109	Hold down Battery Dash Mount
12	145709	Nut Push Nylon 1/4"
16	176138	Switch Interlock Push-In
21	175688	Harness Asm. Light T-Lock w/4152J
22	4152J	Bulb
24	185464	Cable Starter 6 Ga. 22" Red
25	146149	Cable 6 Ga. Red 12.5" w/16 Wire
26	108824X	Fuse
27	73510400	Nut Keps Hex 1/4-20 unc
28	170697	Cable, Ground
29	121305X	Switch, Plunger
30	175566	Switch, Ign
33	140403	Key, Ignition
40	188033	Harness Ign.
41	17720408	Screw Thd Cut 1/4-20 x 1/2
42	131563	Cover, Terminal
43	178861	Solenoid W/Brass Plunger
45	177500	Ammeter
46	177501	Meter, Hour
50	174652	Switch, PTO
79	175242	Socket Asm Bulb Twistlock
91	184932	Tachometer Round

NOTE: All component dimensions given in U.S. inches.
1 inch = 25.4 mm.

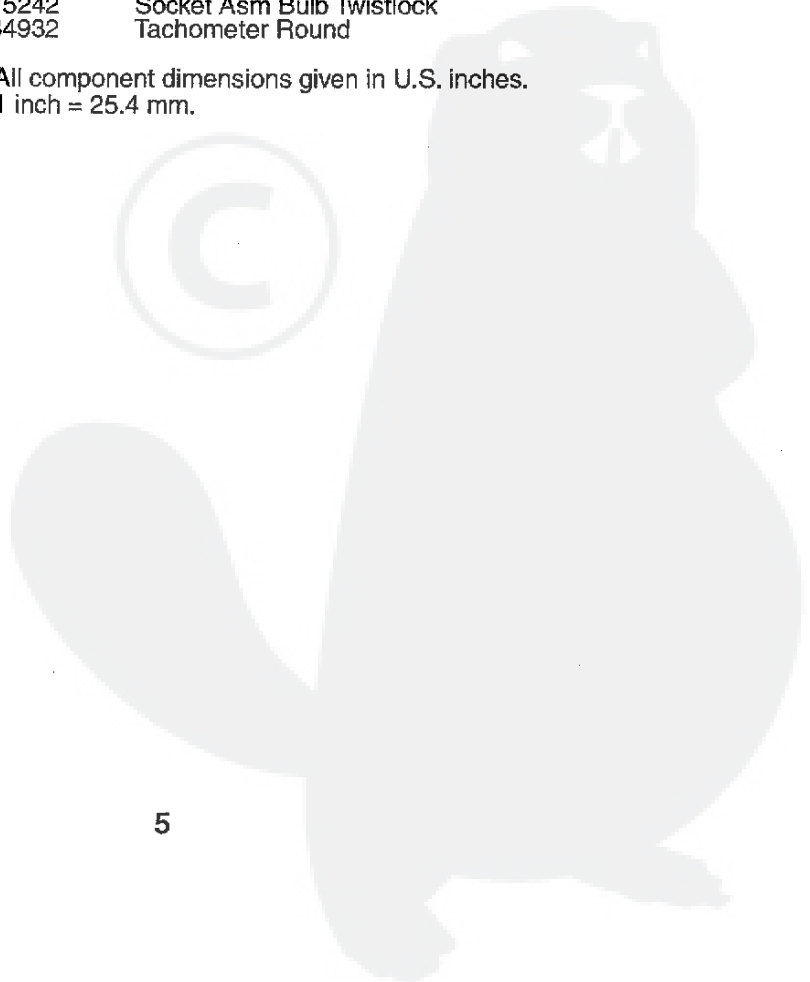

REPAIR PARTS

TRACTOR- -MODEL NO. 917.277480

CHASSIS AND ENCLOSURES

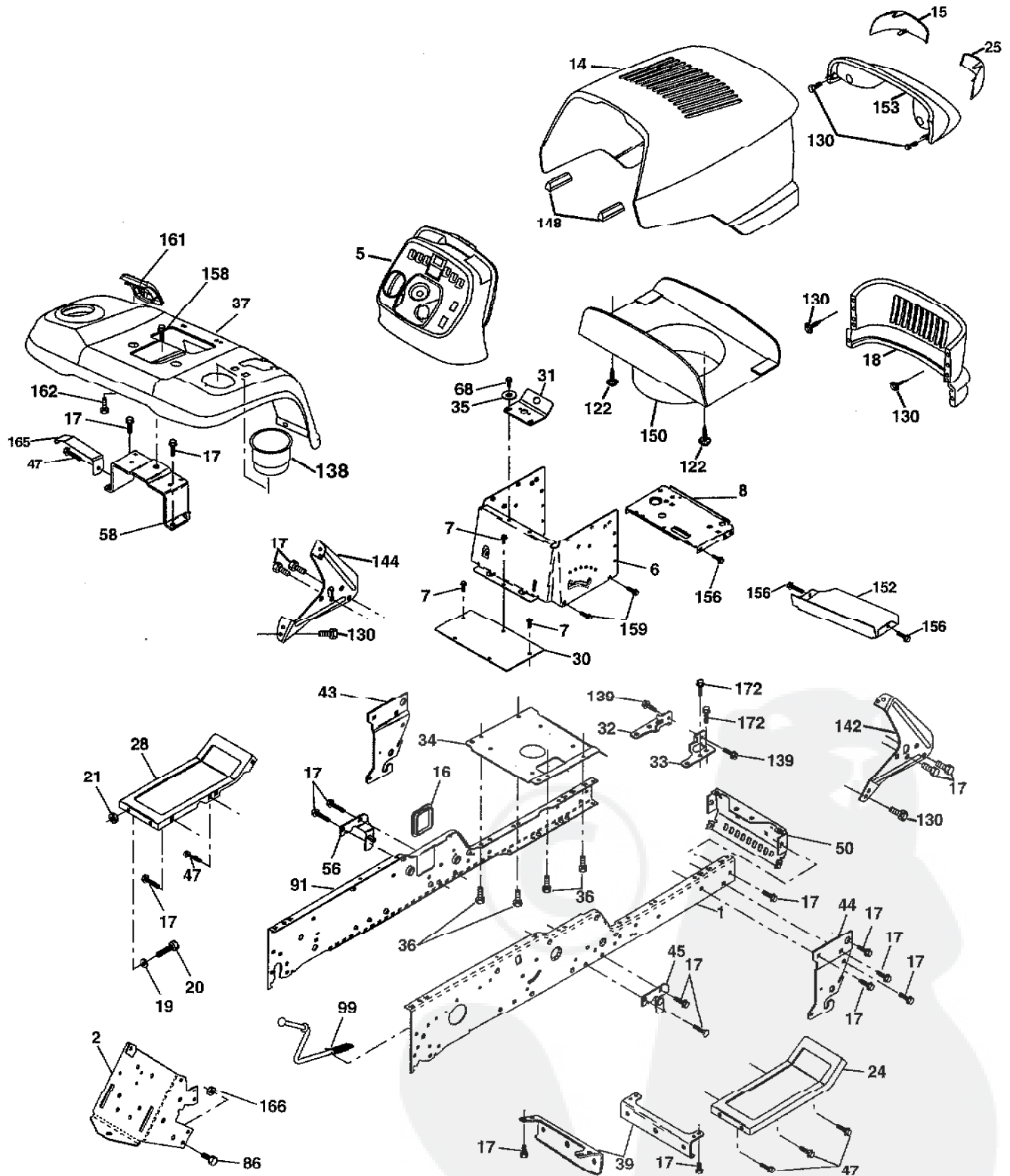

chassis-stealth_39-vgt

REPAIR PARTS

TRACTOR- -MODEL NO. 917.277480

CHASSIS AND ENCLOSURES

KEY NO.	PART NO.	DESCRIPTION	KEY NO.	PART NO.	DESCRIPTION
1	180375	Kit Rail Chass. RH GT Serv.	47	17490608	Screw Thdrol. 3/8-16 x 1/2
2	175282	Drawbar, Gt	50	175476	Bracket, Chassis Front
5	187939X428	Dash	56	176016	Bracket Asm., Susp Chas. Lh
6	157882	Dash, Lower Vgt One Piece	58	183569	Bracket Asm., Fender
7	17720408	Screw, Thd Cut 1/4-20 x 1/2	68	17490508	Screw Thdrol. 5/16-18 x 1/2
8	184668	Support, Battery	86	74780716	Bolt Fin Hex 7/16-14 Unc x 1
14	175260X615	Hood Asm	91	180374	Kit Rail Chass. LH GT Serv.
15	161841	Lens LH	99	177143	Rod By Pass
16	121794X	Cover, Access	122	161464	Screw Hex Wshd 8-18 x 7/8
17	17000612	Screw 3/8-16 x .75	130	191611	Screw #10 x 3/4
18	174515X615	Grille	138	191121X428	Cup Holder
19	19131312	Washer 13/32 x 13/16 x 12 Ga.	139	171873	Bolt Shoulder 5/16-18 TT
20	STD523710	Bolt, Fin Hex 3/8-16 x 1	142	161897	Bracket Dash Rh
21	STD541437	Nut Crownlock 3/8-16 Unc	144	161900	Bracket Dash Lh
24	179717X615	Footrest, RH	148	164655	Extrusion Bumpers
25	161842	Lens RH	150	175352	Duct Heat Hood
28	179716X615	Footrest, LH	152	177956	Shield Heat
30	145052	Saddle, Hydro	153	179763	Light Asm. Dual
31	161419	Brace, Supt 1-pc VGT	156	17000512	Screw 5/16-18 x 3/4
32	161327	Bracket, Pivot Chassis Lh	158	17670608	Screw Thdrol 3/8-16 x 1/2
33	161326	Bracket, Pivot Chassis Rh	159	17000612	Screw Hexwsh Thdrl 3/8-16 x 3/4
34	177018	Plate Asm Engine	161	179612X428	Console Fuel Window
35	191111116	Washer 11/32x11/16 x 16 Ga.	162	142432	Screw Hex Wsh Hi-Lo 1/4-1/2
36	17060512	Screw 5/16-18 x 3/4	165	183554	Bracket Support Fuel Tank
37	178510X615	Fender Pnt	166	73680700	Nut Crown Lock 7/16-11
39	175278	Bracket, Axle Front	172	17120614	Screw 3/8-16 x .875
43	136939	Bracket, Spnsn Front Lh			
44	136940	Bracket, Spnsn Front Rh			
45	176018	Bracket Asm., Susp Chas. Rh			

NOTE: All component dimensions given in U.S. inches.
1 inch = 25.4 mm.

REPAIR PARTS

TRACTOR- -MODEL NO. 917.277480

DRIVE

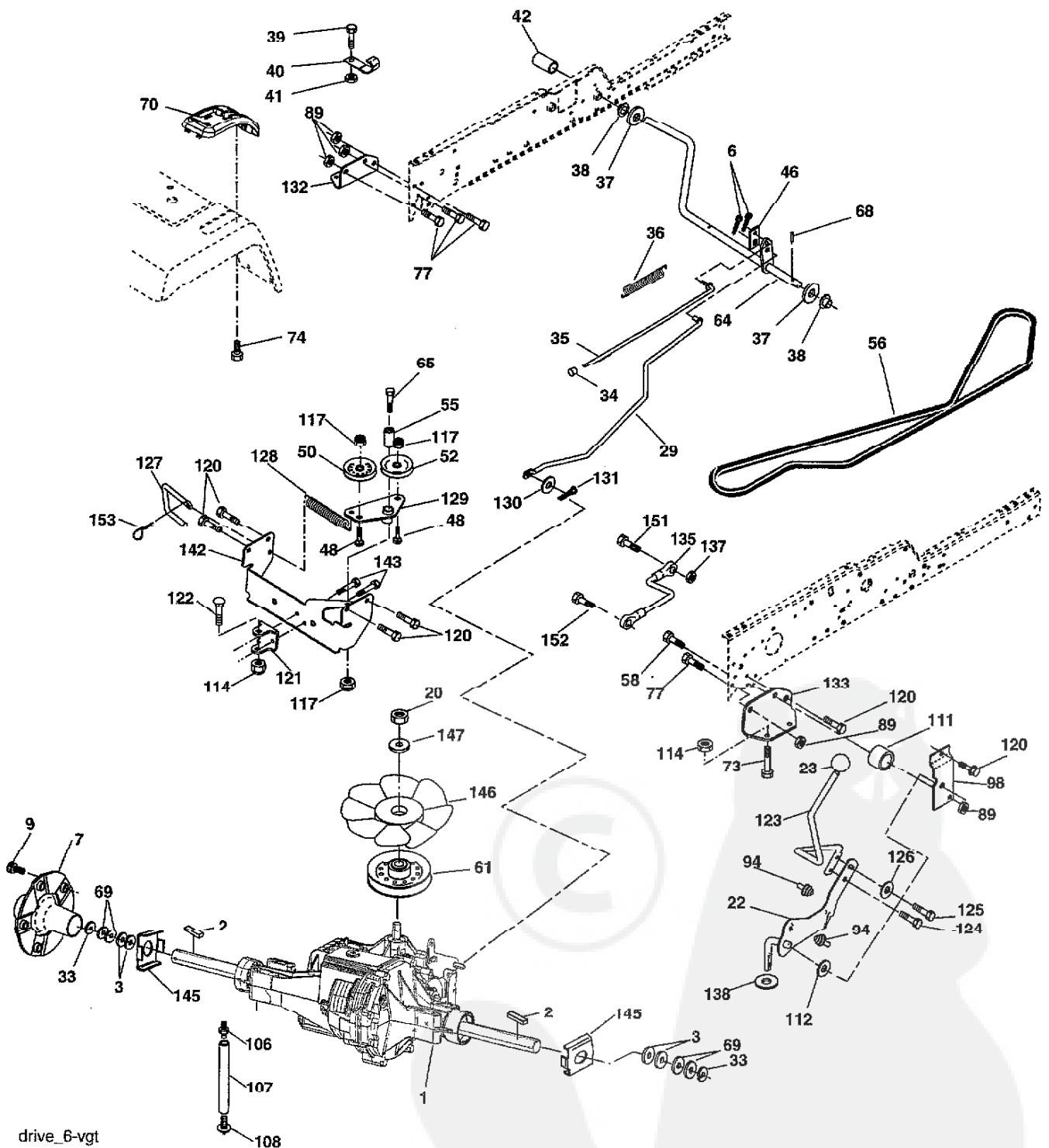

REPAIR PARTS

TRACTOR- -MODEL NO. 917.277480

DRIVE

KEY NO.	PART NO.	DESCRIPTION	KEY NO.	PART NO.	DESCRIPTION
1	-----	Transaxle Hydro Gear 311-3500 (See Breakdown)	98	141004	Bracket Shift
2	7070E	Key 1/4 x 2.5	106	142918	O-Ring Asm Hydro Gear
3	7563R	Washer Thrust	107	154739	Line Fuel Hydro 15" VGT
6	STD561210	Pin, Cotter	108	142917	Cap Asm Vent Hydro Gear 70109
7	140507	Hub Wheel Asm.	111	156240	Spacer Shift Lever VGTH
9	140080	Bolt Hub	112	178558	Washer Nylon High Temp
20	73940800	Nut	114	73800500	Nut Lock Hx W/Ins 5/16-18 unc
22	180235	Lever Asm Shift Lower	117	73900600	Nut, Lock Fig. 3/8-16
23	130564	Knob	120	17000612	Screw 3/8-16 x .75
29	176600	Brake, Rod	121	175611	Bracket Strap Torque
33	12000053	Ring F	122	72010520	Bolt RDHD SQ 5/16-18 unc x 2-1/2
34	71673	Cap, Parking Brake	123	183254	Rod Shift
35	137648	Rod, Parking Brake	124	165492	Bolt Shoulder 5/16-18 x .561
36	149412	Spring, Drive Ground	125	17000512	Screw 5/16-18 x 3/4
37	121749X	Washer 25/32 x 1-1/4 x 16 Ga.	126	166002	Washer SRRTD 5/16ID x 1.0 x .125
38	150035	Nyliner	127	177362	Link Control Clutch
39	74321016	Screw, Fin. #10-24 x 1	128	176624	Spring Drive GRND
40	178575	Actuator, Interlock Switch	129	179473	Bracket Asm Idler Tensioning
41	73931000	Nut Centerlock 10-24 unc	130	19131016	Washer 13/32 x 5/8 x 16 Ga.
42	8883R	Cover, Pedal	131	76020312	Pin Cotter 3/32 x 3/4
46	145170	Retainer, Spring	132	175467	Bracket Mtg Hydro 3500 LH VGT
48	72110614	Bolt, RDHD 3/8-16 x 1-3/4 Gr. 5	133	175168	Bracket Mtg Hydro 3500 RH VGT
50	131494	Pulley, Idler, Flat	135	177364	Link Asm Control Hydro 3500
52	127783	Pulley, Idler, Grooved	137	1685H	Nut Lock 5/16-18 NC Thd
55	105706X	Bearing, Idler	138	1370H	Washer Thrust 5/8 x 1.10 x 1/32
56	161597	V-Belt	142	175469	Strap Torque HG-3500
58	71760724	Bolt Fin Hex 7/16-14 x 1-1/2	143	17060512	Screw Thdrol 5/16-18 x 3/4
61	143995	Pulley, Transaxle	145	163168	Washer Axle Flange
64	176601	Shaft, Clutch/Brake Pedal	146	140462	Fan 7" Hydro
65	179613	Bolt, Shoulder	147	141322	Washer
68	STD571812	Pin, Roll	151	74760514	Bolt Fin Hex 5/16-18 unc x 7/8
69	123800X	Washer 1-1/32 x 1-5/8 x 16 Ga.	152	178705	Bolt Hex 5/16-18 x 1
70	179121X428	Console Automatic YT/GT	153	4497H	Retainer Spring
73	74490548	Bolt Hex Fighd 5/16-18 x 3 Gr. 5			
74	142432	Screw Hex Wsh. 1 li-Lo 1/4-1/2			
77	74780716	Bolt Fin Hex 7/16-14 x 1			
89	73680700	Nut Crownlock 7/16-14 unc			
94	133835	Fastener Christmas Tree			

NOTE: All component dimensions given in U.S. inches
1 inch = 25.4 mm

REPAIR PARTS

TRACTOR- -MODEL NO. 917.277480

STEERING ASSEMBLY

KEY NO.	PART NO.	DESCRIPTION
1	159944X428	Wheel, Steering
2	178557	Axle Asm., Front
3	183226	Fitting, Grease
4	161849	Spindle Asm, LH
5	161848	Spindle Asm., RH
6	6266H	Bearing, Race Thrust Harden
7	121748X	Washer 25/32 x 1-5/8 x 16 Ga.
8	12000029	Ring, Klip #T5304-75
9	184946X505	Cap, Spindle
10	74781044	Bolt, Fin Hex 5/8-11 x 2-3/4
11	136518	Spacer Bearing Axle Front
12	73901000	Nut, Lock Flange 5/8-11 unc
13	121749X	Washer 25/32 x 1-1/4 x 16 Ga.
14	STD551137	Washer, Lock Hvy Hlcl Spr 3/8
15	73540600	Nut, Crownlock 3/8-24
16	186814	Shaft Asm., Steering
18	175572	Draglink, Ball Joint Solid Vgt
19	156011	Support Asm., Steering Vgt
20	163887X428	Boot, Steering
21	159945	Adapter, Wheel Steering
22	155105	Bushing, Strg. Blk
23	152927	Screw
26	159946X428	Insert , Wheel Steering
27	3366R	Bearing, Col. Strg.
28	17000612	Screw, 3/8-16 x 3/4
29	104239X	Bearing, Flange
31	138136	Bushing, Nyliner Snap
32	19111610	Washer 11/32 x 1 x 10 Ga.
33	STD551131	Washer, Lock Hvy Hlcl Spr 5/16
34	74780512	Bolt Fin Hex 5/16-18 unc x 3/4
35	187039	Gear, Sector Steering
36	186799	Tie Rod
41	155246	Bracket Switch Interlock VGT 97
42	17490508	Screw Thdrol 5/16-18 x 1/2 Tyt
44	160135X428	Extension Steering
45	19182411	Washer 9/16 x 1-1/20 x 11 Ga.
46	19131610	Washer 13/32 x 1 x 10 Ga.
47	170471	Bracket Asm Idler Stationary
49	175820	Pulley Idler Flat
50	73900600	Nut Lock Flg 3/8-16 unc
51	73940800	Nut Hrx Jam Toplock 1/2-20unf
52	175553	Clip Steering
53	188967	Washer Harden .793 x 1.637 x .060

NOTE: All component dimensions given in U.S. inches.
1 Inch = 25.4 mm.

REPAIR PARTS

TRACTOR- -MODEL NO. 917.277480

DECALS

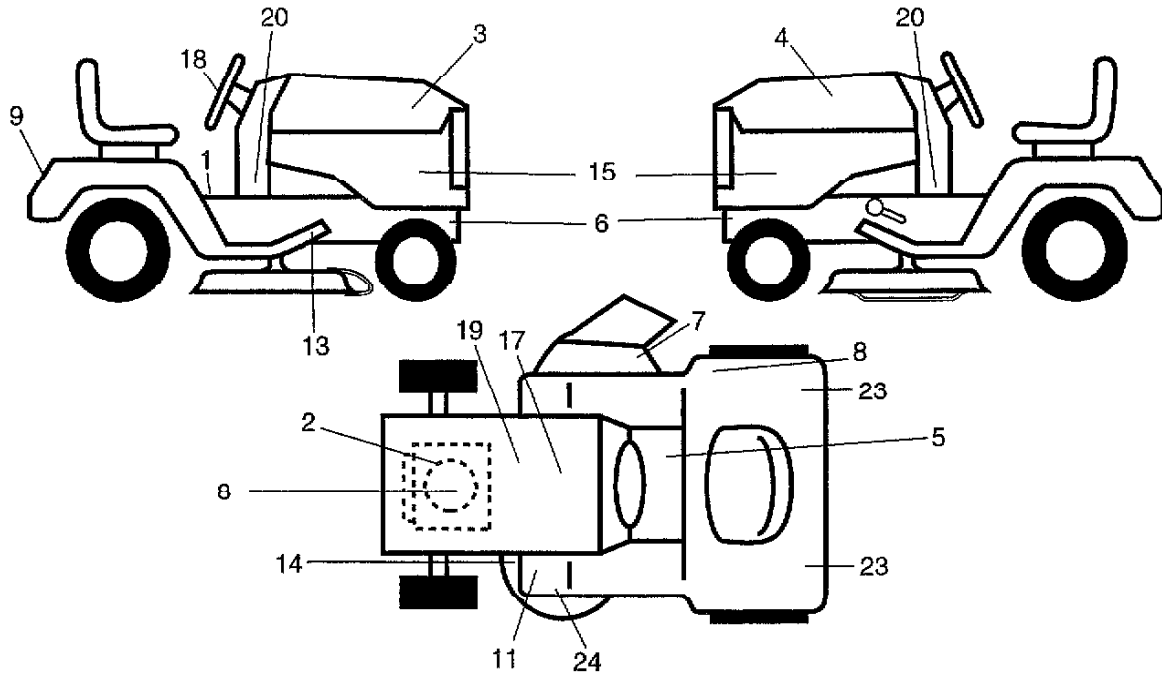

KEY NO.	PART NO.	DESCRIPTION
1	145498	Decal, Read Owner's Manual
2	189248	Decal, Hp Engine
3	186242	Decal, Hood RH
4	186243	Decal, Hood LH
5	140837	Decal, Brake Parking Saddle
6	159736	Decal, Hot Muffler
7	182166	Decal, Cutfinger
8	180433	Decal, Fender DB/CE
9	186572	Decal, Fender
11	177873	Decal, Clutch/Brake
13	177554	Decal, Belt Drive
14	175291	Decal, Deck Schematic
15	186725	Decal, Side Panel

KEY NO.	PART NO.	DESCRIPTION
17	145005	Decal, Btry Dngr/Psn
18	164065	Decal, Insert Strg
19	138047	Decal, Battery
20	182786	Decal, Lower Dash
23	106202X	Reflector, Taillight
24	178482	Decal Deck Hvy Duty
--	162598	Decal, Load Limit
--	166960	Decal, Bypass Control (Drawbar)
--	179768X428	Pad, Footrest LH
--	179769X428	Pad, Footrest RH
--	190716	Operator's Manual (Euro)
--	190717	Operator's Manual (Scand)
--	190718	Manual Parts

WHEELS & TIRES

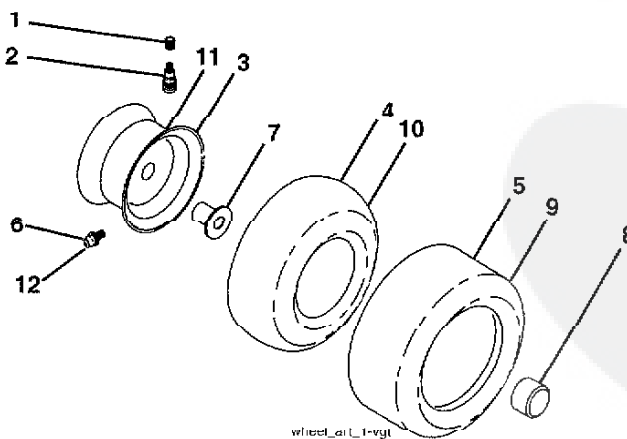

KEY NO.	PART NO.	DESCRIPTION
1	59192	Cap Valve Tire
2	65139	Stem Valve
3	148736X624	Rim Asm Front
4	8134H	Tube, Front (Service Item Only)
5	148741	Tire, Front
6	278H	Fitting Grease (Front Wheel Only)
7	9040H	Bearing Flange (Front Wheel Only)
8	104757X428	Cap Axle (Front Wheel Only)
9	151607	Tire Rear
10	7154J	Tube Rear (Service Item Only)
11	148738X624	Rim Asm Rear
12	6856M	Fitting Grease
--	144334	Sealant, Tire (10 oz. Tube)

NOTE: All component dimensions given in U.S. inches
1 inch = 25.4 mm

REPAIR PARTS

TRACTOR- -MODEL NO. 917.277480

ENGINE

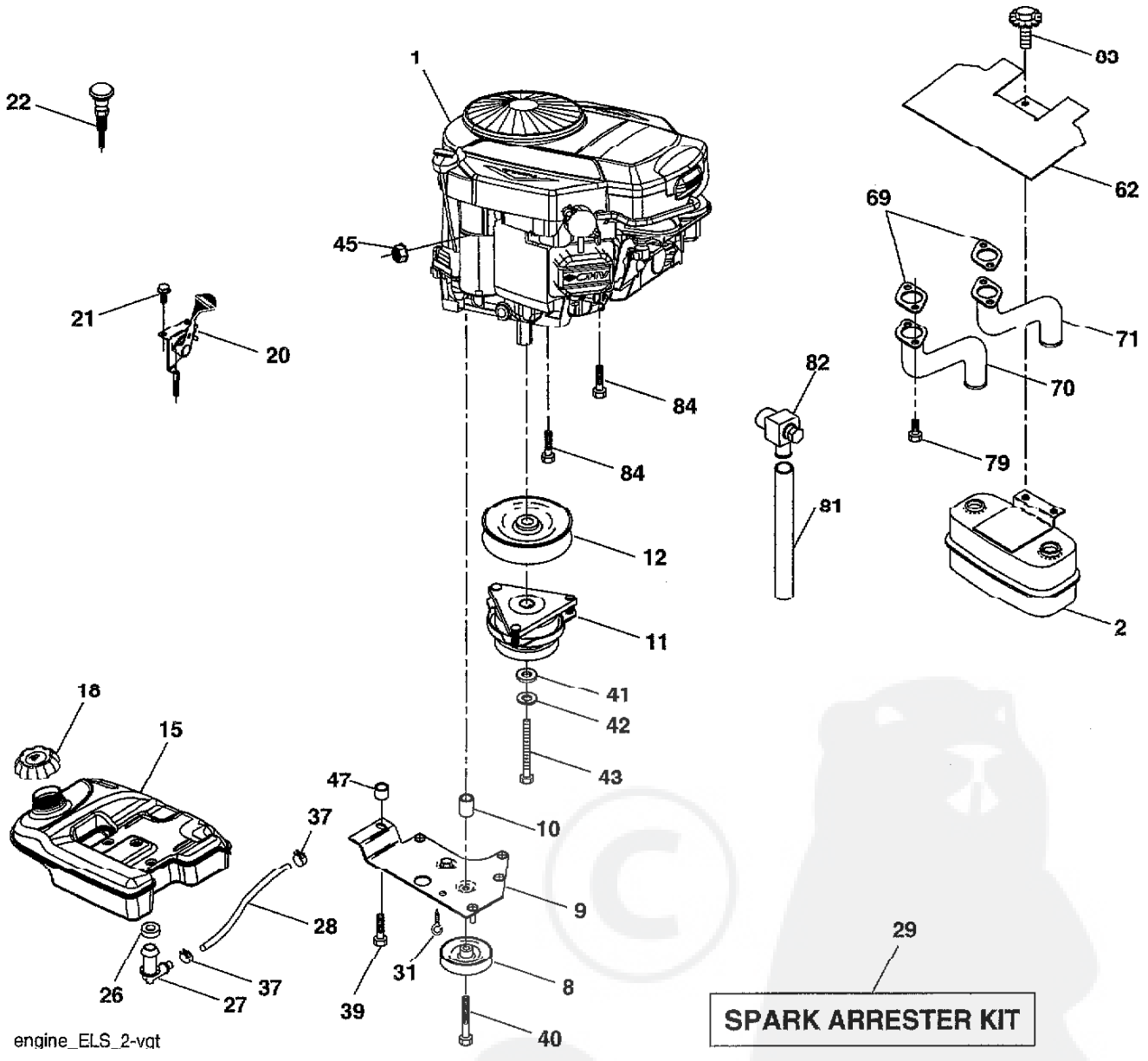

REPAIR PARTS

TRACTOR- -MODEL NO. 917.277480

ENGINE

KEY NO.	PART NO.	DESCRIPTION
1	-----	Engine Briggs 446777-0365-E1 (See Breakdown)
2	149723	Muffler
8	121361X	Pulley V-Idler
9	177748	Belt Engine Keeper Asm
10	175287	Bushing
11	179335	Clutch OGUHA
12	143996	Pulley Engine VGT Elect Clutch
15	179115	Tank Fuel Rear 5.0 YT/GT
18	179124X428	Cap Fuel
20	175437X505	Control Throttle
21	191611	Screw 10 x 3/4 Single Lead-Hex
22	187767X505	Control Choke
26	3645J	Bushing
27	139277	Stem Tank Fuel
28	7834R	Fuel Line
29	137180	Spark Arrester Kit
31	145006	Clip Push-In
37	123487X	Clamp Hose
39	17490636	Screw TT 3/8-16 x 2-1/4 unc
40	17490664	Screw TT 3/8-16 x 4
41	126197X	Washer 1-1/2 OD x 15/32 ID x .250
42	STD551143	Washer Lock 7/16
43	179953	Bolt Hex 7/16 - 20 x 3.75. Gr. 5
45	73510400	Nut Keps Hex 1/4-20 unc
47	175288	Bushing
62	146629	Shield Heat Muffler
69	165391	Gasket
70	176069	Tube Exhaust LH
71	176070	Tube Exhaust RH
79	183906	Screw Socket Head 5/16-18 x 1
81	188800	Drain Tube
82	188799	Drain Valve
83	171877	Bolt 5/16-18 unc x 3/4 w/Sems
84	17060624	Screw 3/8-16 x 1/2

NOTE: All component dimensions given in U.S. inches
1 inch = 25.4 mm

REPAIR PARTS

TRACTOR- -MODEL NO. 917.277480

MOWER LIFT

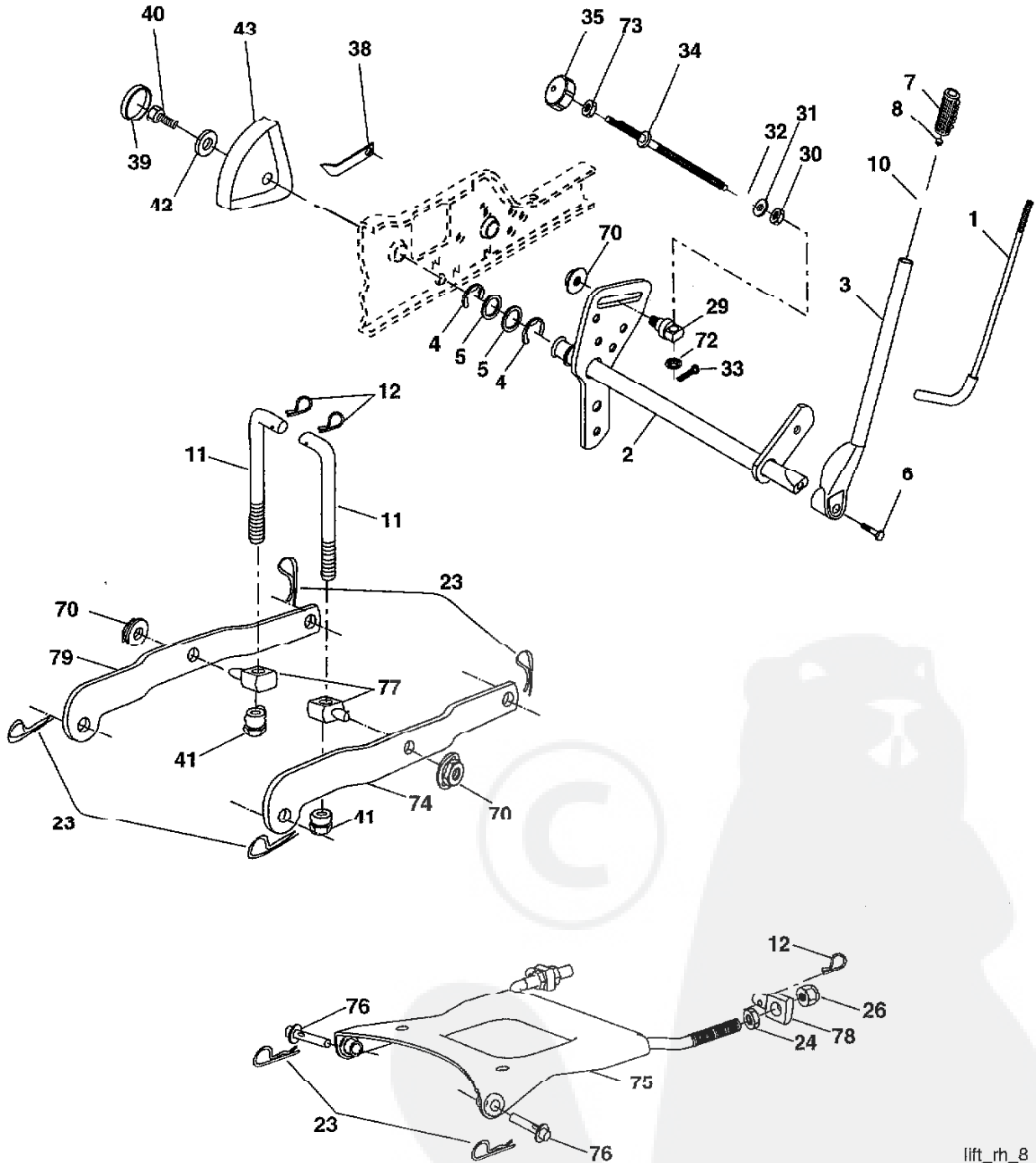

lift_rh_8

REPAIR PARTS

TRACTOR- -MODEL NO. 917.277480

MOWER LIFT

KEY NO.	PART NO.	DESCRIPTION
1	121006X	Rod Asm., Lever
2	180045	Shaft Asm., Lift Vgt
3	159189	Lever Asm., Lift Rh
4	12000022	E-Ring Truarc #5133-87
5	19292016	Washer 29/32 x 1-1/4 x 16 Ga.
6	71110624	Bolt, Fin Hex 3/8-16 x 1-1/2
7	175830	Grip Handle Premium LTX
8	175831X505	Button, Plunger
10	183894	Spring 0.62 OD x 2.125
11	175375	Link Lift
12	163552	Retainer, Spring
23	STD624008	Retainer, Spring
24	73350800	Nut, Jam Hex 1/2-13 Unc
26	73800800	Nut, Lock 1/2-13 Unc
29	150233	Trunnion, Infin Height
30	110807X	Nut, Special
31	19131016	Washer 13/32 x 5/8 x 16 Ga.
32	137150	Spring, Compression Inf Hgt
33	STD560907	Pin, Cotter 3/32 x 1/2
34	137167	Rod, Adj Lift
35	138057	Knob, Inf 3/8-16 Unc
38	155097	Pointer, Height Indicator
39	123935X	Plug, Hole
40	17060516	Screw 5/16-18 x 1 SMGM. Tap/R
41	175994	Nut Lift Link 7/16-20
42	19112410	Washer 11/32 x 1-1/2 x 10 Ga.
43	123934X	Scale, Indicator Height
70	145212	Nut Hex Flange Lock
72	110452X	Nut Push Phos & Oil
73	73350600	Nut Hex Jam 3/8-16 Unc
74	175802	Arm Suspension Rear Rh
75	175805	Plate Asm Susp. Front VGT
76	175560	Pin Flange
77	176205	Trunnion Susp. Arm
78	175689	Trunnion Front Susp.
79	175378	Arm, Suspension Rear LH

NOTE: All component dimensions given in U.S. inches
1 inch = 25.4 mm

REPAIR PARTS

TRACTOR- -MODEL NO. 917.277480

MOWER

KEY NO.	PART NO.	DESCRIPTION	KEY NO.	PART NO.	DESCRIPTION
1	180358	Deck Weldment Mower 48	52	175820	Pulley Idler Flat
3	178915	Bracket Asm., Sway Bar	56	155986	Bar Pnt Adj.
5	4939M	Retainer Spring	57	156941	Pin Head Rivet
6	178024	Sway Bar	90	74760516	bolt Hex Hd. 5/16-18 unc x 1
8	174365	Bolt 7/16 Asm. Blade (The following blades are available)	91	180535	Bracket Asm. Noseroller RH
11	180054	Blade, 48" Hi-Lift	94	176066	Noseroller
13	174360	Shaft Asm. w/Lower Bearing	95	180534	Bracket Asm Noseroller LH
14	174358	Mandrel Asm.	97	178515	Washer Hardened
15	110485X	Bearing, Ball, Mandrel	98	179479	Spring Primary Drive
16	174493	Stripper Mandrel Deck	99	184058	Pulley Idler"V"
17	72110610	Bolt RDHD Sq Neck 3/8-16x1.25	100	72110616	Bolt RDHD Sqnk 3/8-16 Unc x 2
18	72140505	Bolt, Carriage 5/16-18 x 5/8	110	175016	Arm Spring Secondary
19	132827	Bolt, Hex Hd, Shoulder 5/16-18	112	174387	Link Tension Relief Lever
20	174378	Baffle, Vortex Mower	113	72110506	Bolt 5/16-18 x 3/4
21	73680500	Nut, Crownlock 5/16-18 Unc	114	174384	Tension Asm. Relief Lever
24	105304X	Cap, Sleeve	115	174609	Arm Spring Tension Relief
25	178102	Spring, Torsion	116	184219	Bolt, Shoulder
26	110452X	Nut, Push	117	174873	Gauge Wheel
27	180655X428	Deflector Shield	118	73930600	Nut, Centerlock 3/8-16 Unc
28	19111016	Washer 11/32 x 5/8 x 16 Ga.	119	19121414	Washer 3/8 x 7/8 x 14 Ga.
29	131491	Rod, Hinge	121	174371	Spring Secondary Drive
30	173984	Screw, Thdroll Washer Head	122	174606	Bushing Pivot Tension Relief
31	187690	Washer, Spacer	126	174372	Arm, Idler, Primary Deck
32	173436	Pulley, Mandrel	130	17000616	Screw 3/8-16 x 1.0
33	178342	Nut, Flg. Top Lock Cntr. 9/16	180	73800500	Nut Lock Hex w/Inc. 5/16-18 unc
37	177968	Pulley, Idler, Flat	182	179127	Rod Roller Nose
39	174375	Pulley, Idler, Driven	183	163552	Retainer Spring
42	165723	Spacer, Retainer	184	173979	Keeper Belt Idler
43	174373	Arm, Idler Secondary	--	174356	Mandrel Assembly
45	180806	Cover, Mandrel Deck	--	181579	(Includes Key Nos. 13-15 and 33) Replacement Mower, Complete (Std. Deck-Order separately nose roller components Key Nos. 91- 95 and 132, 182, and 183.)
46	137729	Screw, Thdroll. 1/4-20 x 5/8			
47	180808	V-Belt, Mower, Secondary			
48	174368	V-Belt, Mower, Primary			
49	73900600	Nut, Lock 3/8-16 Unc			
50	72110612	Bolt, Carr. 3/8-16 x 1-1/2 Gr. 5			

NOTE: All component dimensions given in U.S. inches
1 inch = 25.4 mm

REPAIR PARTS

TRACTOR- -MODEL NO. 917.277480

TRANSAXLE -- MODEL NUMBER 311-3500

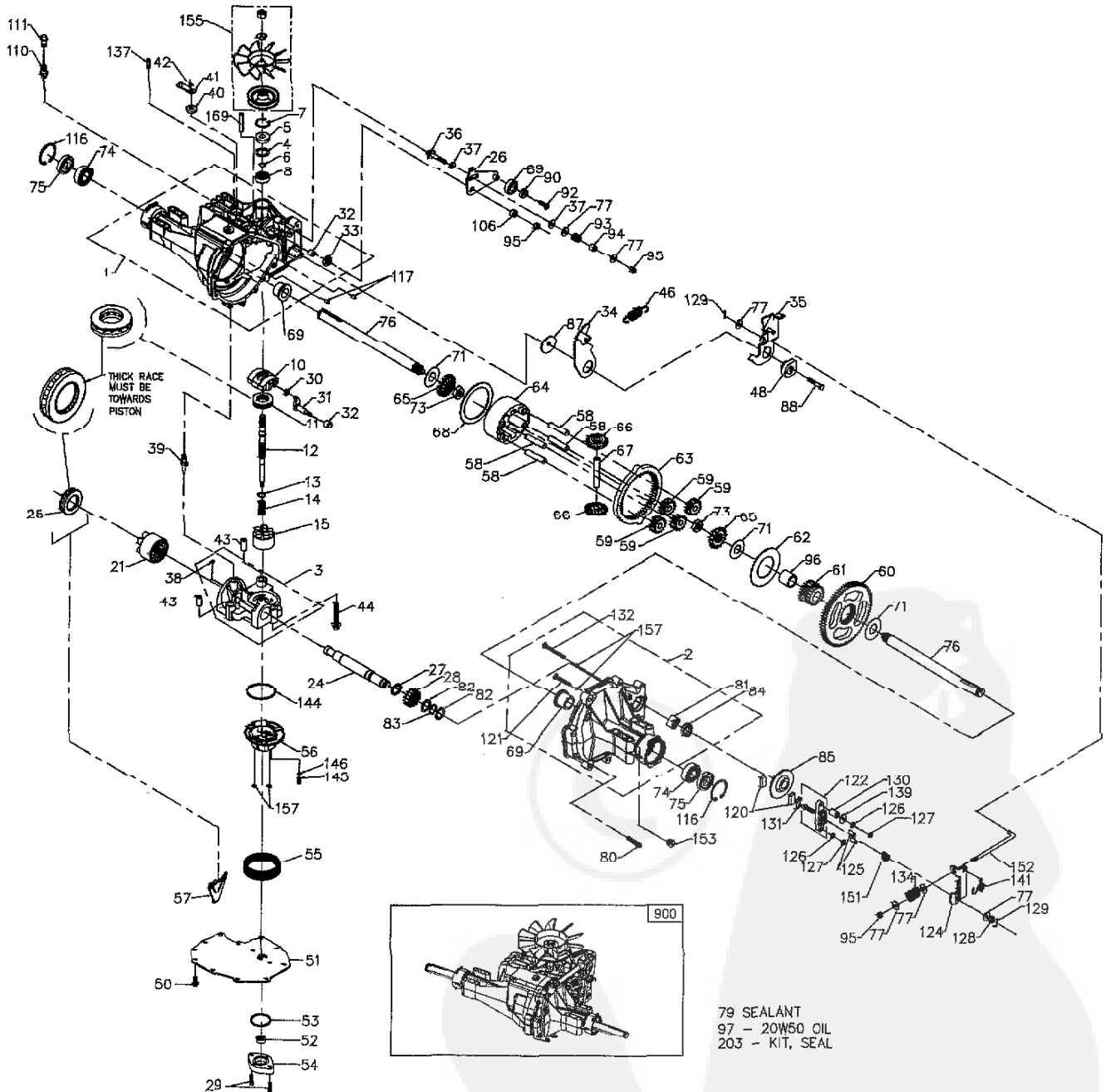

REPAIR PARTS

TRACTOR--MODEL NO. 917.277480

TRANSAXLE -- MODEL NUMBER 311-3500

KEY NO.	PART NO.	DESCRIPTION	KEY NO.	PART NO.	DESCRIPTION
1	161122	Kit, Housing Main, Lip Seal, Flange Bearing, Trunnion Bushing, Cradle Bearing	69	169534	Bearing, Flange (310-3000)
2	178317	Kit, Housing R/h, Flange Bearing, O-ring, Rib Neck Bolt, 2" Rib Neck Bolt, 3", Needle Bearing (SCE1412), Lip Seal (.875 ID X L.3 OD X .25)	71	161155	Washer, Flat (1.00 ID) (310-3000)
3	184703 Kit,	Center Section, Bushing .50 X .60 X .50, Bushing .90 X L.02 X .75, Plate, Bypass, Check Plug Assembly, .044, Check Plug Assembly, No Bleed Spacer (BDP, BDU 10)	73	161156	Nut, 5/8-18 Hex Jam (310-3000)
4	161125	Seal, Lip	74	169535	Bearing, Ball (310-3000)
5	142932	Retaining Ring	75	161157	Seal, Lip (310-3000)
6	142928	Retaining Ring	76	161158	Shaft, Axle (310-3000)
7	142933	Bearing, Ball	77	142884	Washer, Flat
8	142934	Swash Plate (BDP, BDU 10)	79	178322	Sealant Tube
10	169524	Bearing, Thrust (10cc)	80	161159	Screw, Torx Head 5/16-18 (310-3000)
11	173159	Shaft, Input (310-3000)	81	161160	Bearing, Needle (210-3000)
12	161126	Washer, Block Thrust	82	161161	Washer, Flat (0.880 ID) (310-3000)
13	142978	Spring, Helical Compression	83	161162	Ring, Retaining (310-3000)
14	142977	Kit, Cylinder Block (10cc), 10cc Cylinder Block, 10cc Piston, 10cc Piston Spring, Piston Seat Washer	84	161163	Seal, Lip (.875 ID X 1.38 OD X .25) (310-3000)
15	169898	Block, (BD-21& lht), 21cc Cylinder Block, Piston Seat Washer, 21cc Piston, 21cc Piston Spring	85	161164	Brake Disc (310-3000)
21	150786	Shaft, Motor (310-3000)	87	178323	Washer (310-3000)
24	161127	Bearing, Thrust (21cc)	88	178784	Screw, 5/16-24x 1 1/2 Socket Head Cap (310-3000)
25	169526	Control Arm (310-3000)	89	178783	Bearing, Ball
26	161128	Spacer (310-3000)	90	178326	Spacer, Locating (310-3000)
27	161129	Gear, 16t Pinion	92	178787	Screw (310-3000)
28	161130	Capscrew	93	142969	Spring
29	160527	Guide Block (BD-21)	94	142980	Spacer
30	142941	Trunnion, Tapered Square	95	169537	Nut, Nylon Insert Hex Lock 5/16-24
31	169887	Bearing, Journal	96	169538	Bearing, Sleeve (310-3000)
32	161133	Seal, Lip	97	--	20w-50 Oil
33	142940	Return Arm (310-3000)	106	161166	Spacer, Trunnion (310-3000)
34	178318	Actuating Arm (310-3000)	108	150800	Plug, Plastic Shipping
35	178319	Bolt, Stud 5/16-24	110	150813	O-ring, Fitting, Plastic Hose, O-ring
36	170421	Friction Puck	111	150812	Breather Vent, Plastic, Vent, Plastic Vent, Cap
37	142967	Kit, Bypass Plate	116	169539	Ring, Retaining (310-3000)
38	184694	Bypass Actuator (lht)	117	161100	Pin
39	169529	Seal, Lip	120	142883	Brake Puck
40	142945	Bypass Arm	121	169540	Bolt, 2" Rib Neck (310-3000)
41	142952	Retaining Ring	122	178329	Kit, Brake Yoke
42	142953	Pin	124	178330	Brake Arm
43	142965	Bolt 3/8-24 X 2-1/2	125	170409	Pin, Brake Actuating
44	150797	Spring, Neutral (310-3000)	126	161172	Washer, Lock 1/4
46	184702	Puck, Adjusting (310-3000)	127	161173	Nut, Hex 1/4-20
48	178320	Screw, Hex Head Washer Cap Screw (IZT) 1/4-20 X 3/4	128	170415	Nut, Castle 5/16-24
50	178343	Lower Cover	129	170416	Pin, Cotter 3/32x3/4
51	169530	Gerotor Assembly	130	170411	Spacer, Brake Torsion Spring
52	169531	O-ring	131	142882	Brake Puck Plate
53	144581	Charge Pump Housing	132	169544	Bolt, 3" Rib Neck (310-3000)
54	161139	Kit, Filter, Gasket .10 X .16 X 4.24	134	178331	Brake Comp. Spring
55	178321	Filter	137	178333	Pin, Spring (310-3000)
56	169533	Charge Manifold 310-3000	139	161176	Washer, Flat
57	161142	Retainer, Motor Bearing (310-3000)	141	178335	Spring, Brake Arm Bias
58	161143	Pin, Carrier (310-3000)	144	169545	O-ring
59	161144	Gear, 15t Planet (310-3000)	145	169546	Spring, Relief
60	161145	Gear, 67t Spur (310-3000)	146	169547	Steel Ball 7/16
61	161146	Gear, 21t Sun (310-3000)	151	170417	Brake Spring
62	161147	Plate, Planet Thrust (310-3000)	152	178336	Brake Pull Rod
63	161148	Gear, 51t Ring (310-3000)	153	170434	Plug, Straight Thread 9/16-18
64	161149	Carrier, Planetary (310-3000)	155	178337	Kit, Fan/pulley, Nut, Jam 1/2-20, Washer, OD Slotted, .53 X 1.63 X .06
65	178511	Gear, Bevel (Splined)			Pulley, Fan
66	178512	Gear, Bevel (Splined)	157	169548	O-ring
67	161152	Shaft, Differential (310-3000)	169	184701	Pin, Spring 5/16 X 1.75
68	161153	Plate, Differential Thrust (310-3000)	203	178338	Kit, Seal, Lip Seal 15 X 5 X 37, Lip Seal 12 X 25 X 7, Lip Seal 10 X 25 X 7, O-ring .103 X 1.862, Seal 25 X 52 X 10, Lip Seal .875 ID X L.3 OD X .25, O-ring .070 X .239, Kit, O-ring, Manifold, Pin, Spring 5/16 X 1.75, Pin, Spring 1/4 X 1.00
			900	176057	Transaxle

NOTE: All Component Dimensions Given In U.S. Inches
1 Inch = 25.4 mm

REPAIR PARTS

TRACTOR- -MODEL NO. 917.277480

BRIGGS & STRATON ENGINE - - MODEL NUMBER 446777, TYPE NUMBER 0365-E1

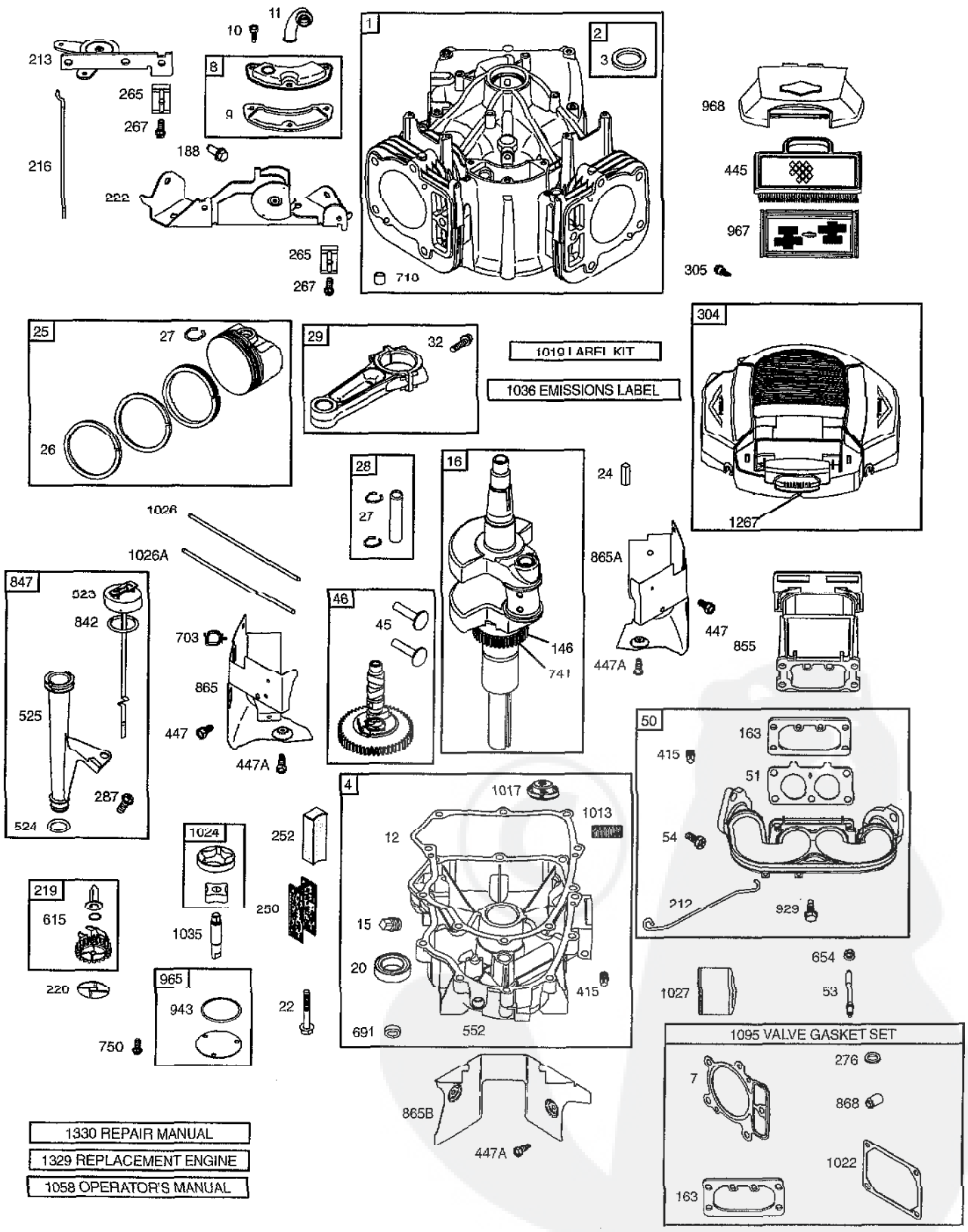

REPAIR PARTS

TRACTOR- -MODEL NO. 917.277480

BRIGGS & STRATON ENGINE - - MODEL NUMBER 416777, TYPE NUMBER 0366-E1

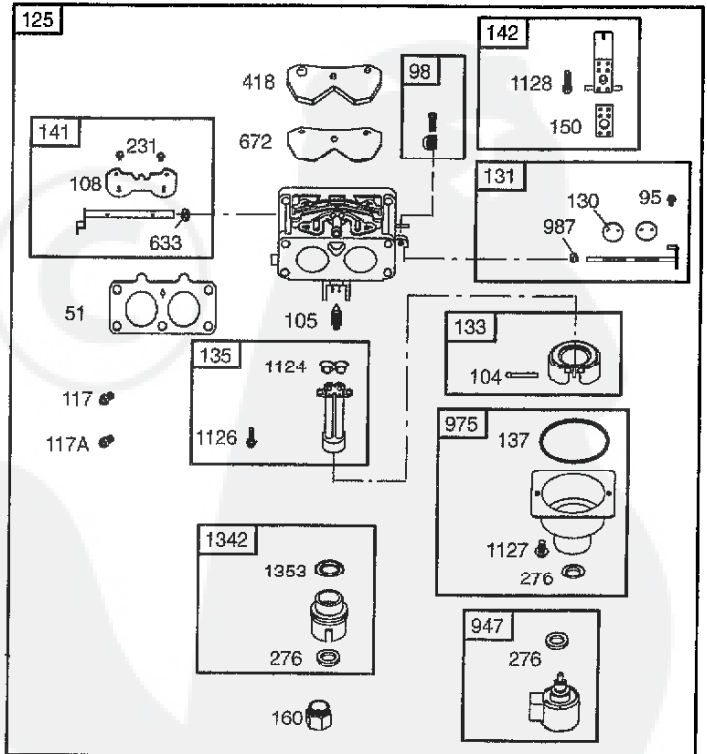
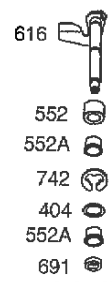
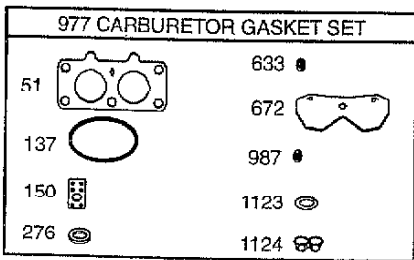
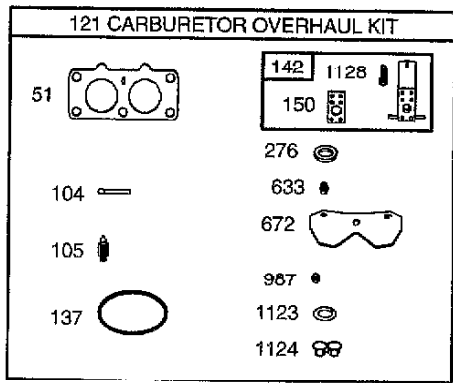
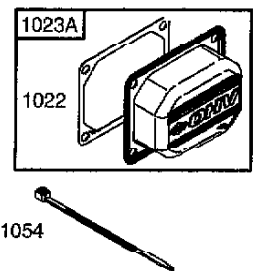
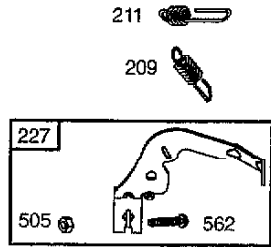
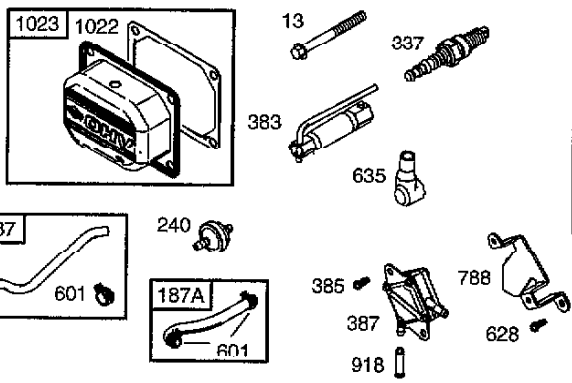
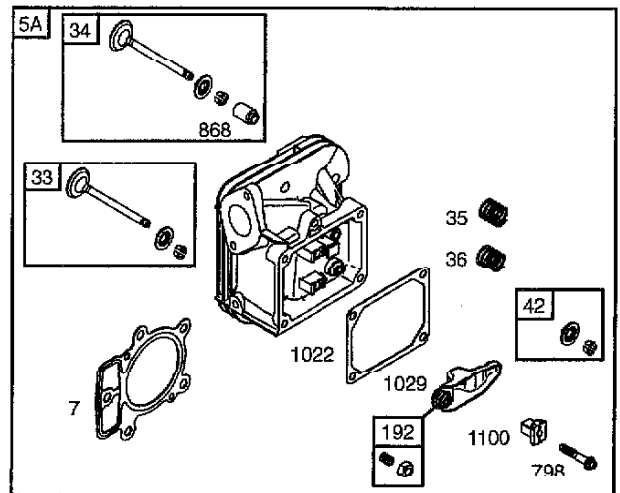
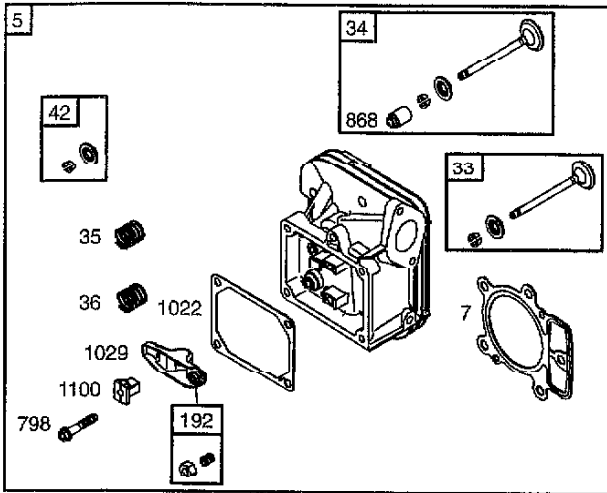

REPAIR PARTS

TRACTOR- -MODEL NO. 917.277480

BRIGGS & STRATON ENGINE - - MODEL NUMBER 446777, TYPE NUMBER 0365-E1

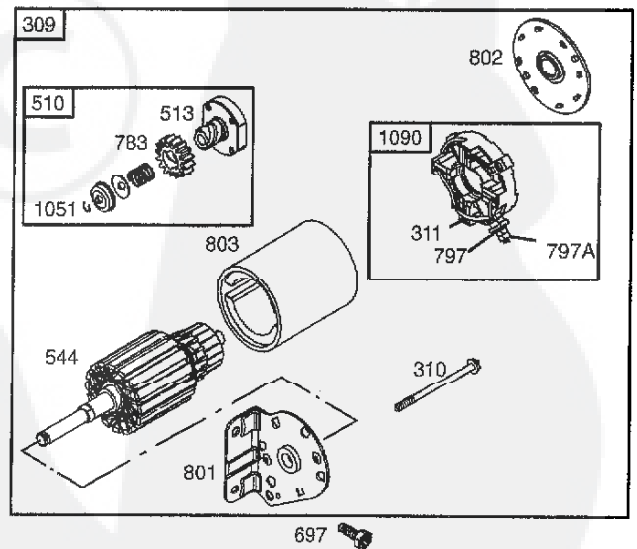
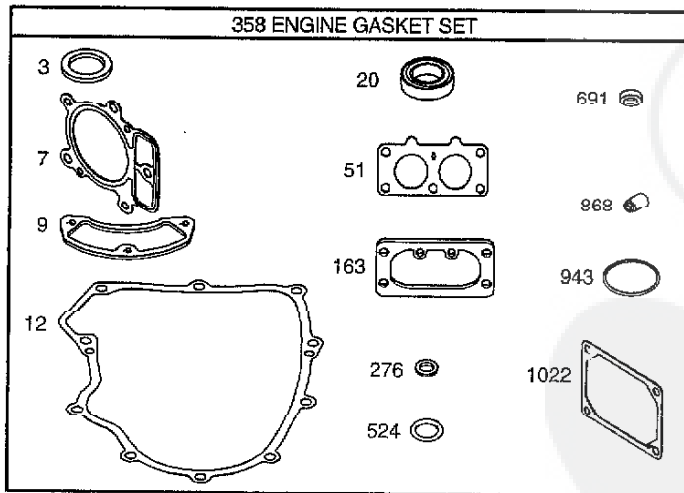
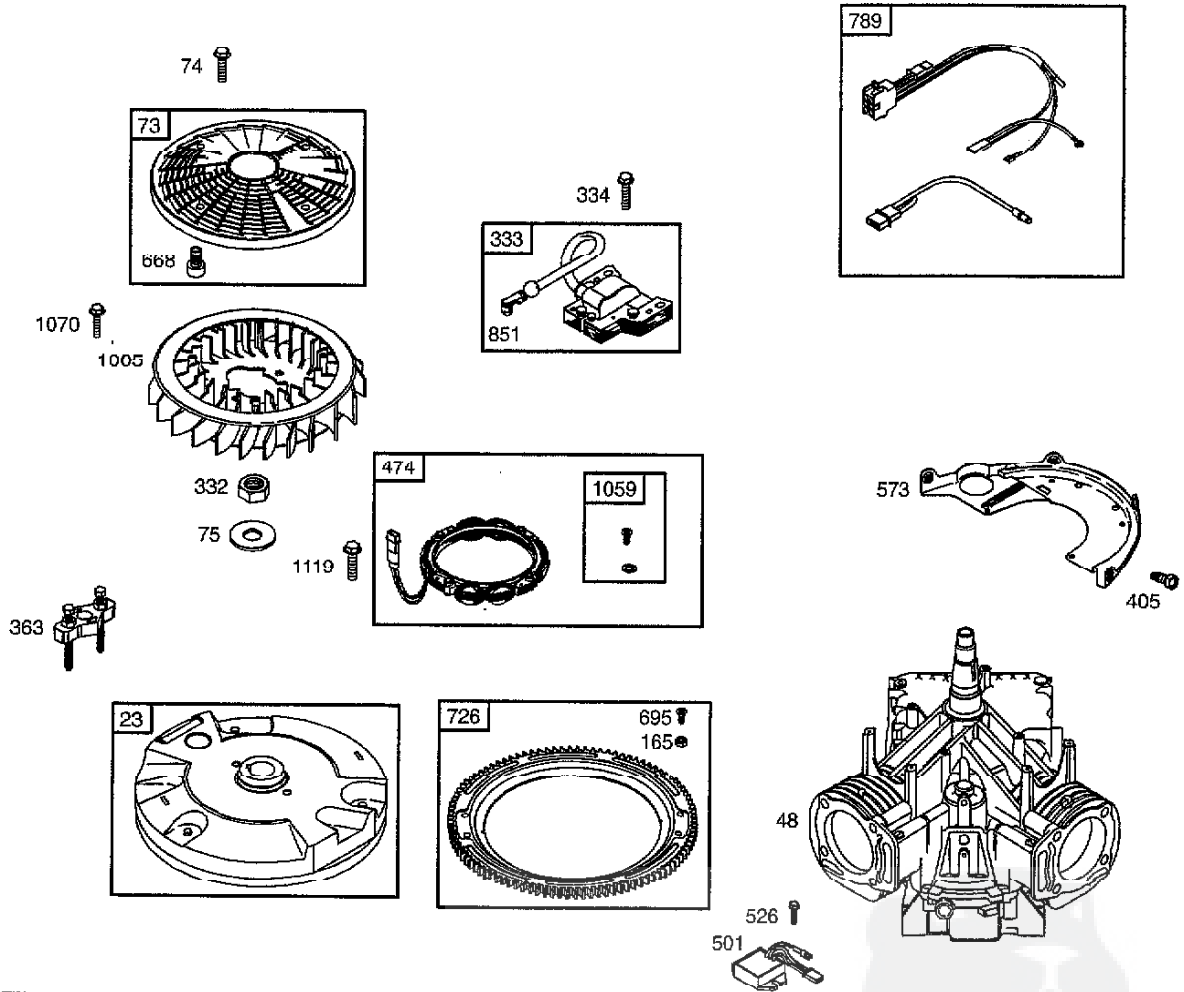

REPAIR PARTS

TRACTOR- -MODEL NO. 917.277480

BRIGGS & STRATON ENGINE - - MODEL NUMBER 446777, TYPE NUMBER 0365-E1

KEY NO.	PART NO.	DESCRIPTION	KEY NO.	PART NO.	DESCRIPTION
1	699753	Cylinder Assembly	133	699724	Float-Carburetor
2	499585	Kit-Bushing/Seal (Magneto Side)	135	699729	Tube-Fuel Transfer
3	391086	• Seal-Oil (Magneto Side)	137	690994	Ø‡ Gasket-Float Bowl
4	699747	Sump-Engine	141	699722	Ø‡ Kit-Choke Shaft
5	697580	Head-Cylinder (Cylinder 1)	142	699726	Ø Nozzle-Carburetor
5A	697581	Head-Cylinder (Cylinder 2)	146	690979	Key-Timing
7	693997	*+ Gasket-Cylinder Head	150	690995	Ø‡ Gasket-Nozzle
8	499601	Breather Assembly	160	699727	Retainer-Solenoid
9	690937	• Gasket-Breather	163	691001	*+ Gasket-Air Cleaner
10	691108	Screw (Breather Assembly)	165	693148	Nut (Ring Gear)
11	690942	Tube-Breather	187	698742	Line-Fuel (Molded)
12	697227	• Gasket-Crankcase	187A	697712	Line-Fuel (Molded)
13	690360	Screw (Cylinder Head)	188	691108	Screw (Control Bracket)
15	690946	Plug-Oil Drain	192	690083	Adjuster-Rocker Arm
16	790132	Crankshaft	209	697674	Spring-Governor
20	690947	• Seal-Oil (PTO Side)	211	691019	Spring-Governed Idle
22	694966	Screw (Engine Sump)	212	695238	Link-Throttle
23	691053	Flywheel	213	691021	Bracket-Choke Control
24	222698	Key-Flywheel	216	691022	Link-Choke
25	697679	Piston Assembly (Standard)	219	698231	Gear-Governor
25	697681	Piston Assembly (.020" Oversize)	220	690412	Washer (Governor Lever)
26	697683	Ring Set-Piston (Standard)	222	698757	Bracket-Control
26	697685	Ring Set-Piston (.020" Oversize)	227	691048	Lever-Governor Control
27	690975	Lock-Piston Pin	231	690718	Screw (Choke Valve)
28	690229	Pin-Piston	240	695666	Filter-Fuel
29	699699	Rod-Connecting	250	690957	Retainer-Breather
32	690976	Screw (Connecting Rod)	252	690956	Collector-Oil
33	697576	Valve-Exhaust	265	691024	Clamp-Casing
34	697464	Valve-Intake	267	695134	Screw (Casing Clamp)
36	690963	Spring-Valve (Intake)	276	690997	•Ø‡‡ Washer-Sealing
36	690963	Spring-Valve (Exhaust)	287	691108	Screw (Dipstick Tube)
42	499586	Keeper-Valve	304	698073	Housing-Blower
45	690977	Tappet-Valve	305	691005	Screw (Blower Housing)
46	699748	Camshaft	309	691262	Motor-Starter
48	698173	Short Block	310	691263	Bolt-Starter Motor
50	695241	Manifold-Intake	311	497608	Brush Set
51	690950	•Ø‡ Gasket-Intake	332	691059	Nut (Flywheel)
53	690951	Stud (Carburetor)	333	691060	Armature-Magneto
54	695240	Screw (Intake Manifold)	334	691061	Screw (Magneto Armature)
73	494439	Screen-Rotating	337	491055s	Spark Plug
74	698425	Screw (Rotating Screen)	358	694012	Set-Engine Gasket
75	691056	Washer (Flywheel)	363	19203	Flywheel Puller
95	690718	Screw (Throttle Valve)	383	19371	Wrench-Spark Plug
98	699721	Kit-Idle Speed	385	691108	Screw (Fuel Pump)
104	694918	Ø Pin-Float Hinge	387	808656	Pump-Fuel
105	698537	Ø Valve-Float Needle	404	690442	Washer (Governor Crank)
108	699723	Valve-Choke	405	697820	Screw (Back Plate)
117	699494	Jet-Main (Standard)	415	690283	Plug
117A	699495	Jet-Main (Standard)			
121	699734	Kit-Carburetor Overhaul			
125	699709	Carburetor			
130	690993	Valve-Throttle			
131	499805	Kit-Throttle Shaft			

- Included in Engine Gasket Set, Key. No. 358
- Ø Included in Carburetor Overhaul Kit, Key. No. 121
- ‡ Included in Carburetor Gasket Set, Key. No. 977
- + Included in Valve Gasket Set, Key. No. 1095

NOTE: All component dimensions given in U.S. inches 1 inch - 25.4 mm

REPAIR PARTS

TRACTOR--MODEL NO. 917.277480

BRIGGS & STRATON ENGINE - - MODEL NUMBER 446777, TYPE NUMBER 0365-E1

KEY NO.	PART NO.	DESCRIPTION	KEY NO.	PART NO.	DESCRIPTION
418	690999	Plate-Carburetor	868	690968	•+ Seal-Valve
445	698754	Filter-Air Cleaner Cartridge	914	691127	Screw (Rocker Cover)
447	691003	Screw (Air Guide Cover)	918	694000	Hose-Vacuum
117A	691108	Screw (Air Guide Cover)	929	695239	Screw (Choke Control Bracket)
474	696458	Alternator	943	690589	• Seal-O Ring (Oil Pump Cover)
501	691185	Regulator	947	699728	Solenoid-Fuel
505	691029	Nut (Governor Control Lever)	965	499613	Cover-Oil Pump
510	696541	Drive-Starter	967	273638	Filter-Pre Cleaner
513	692024	Clutch-Drive	968	698075	Cover-Air Cleaner
523	691036	Dipstick	975	499810	Bowl-Float
524	691032	• Seal-Dipstick Tube	977	699735	Gasket Set-Carburetor
525	691037	Tube-Dipstick	987	691000	Ø‡ Seal-Throttle Shaft
526	691108	Screw (Regulator)	1005	696760	Fan-Flywheel
544		Armature-Starter (Service with 691262 Starter Motor)	1013	690954	Nipple-Oil Filter
552	690552	Bushing-Governor Crank	1017	690770	Screen-Oil Pump
552A	690553	Bushing-Governor Crank	1019	690103	Kit-Label
562	690311	Bolt (Governor Control Lever)	1022	690971	•+ Gasket-Rocker Cover
573	691009	Plate-Back	1023	499599	Cover-Rocker (Cylinder 1)
601	691038	Clamp-Hose	1023A	499600	Cover-Rocker (Cylinder 2)
615	698290	Retainer-Governor Shaft	1024	499054	Pump-Oil
616	691045	Crank-Governor	1026	690981	Rod-Push (Steel)
628	691108	Screw (Fuel Pump Bracket)	1026A	690982	Rod-Push (Aluminum)
633	690998	Ø‡ Seal-Choke/Throttle Shaft	1027	696854	Filter-Oil
635	66538	Boot-Spark Plug	1029	690972	Arm-Rocker
654	690950	Nut (Carburetor)	1035	691042	Shaft-Pump
668	691215	Spacer	1030	697913	Label-Emission
672	690234	Ø‡ Gasket-Carburetor Plate	1051	691265	Ring-Retaining
691	690657	• Seal-Governor Shaft	1054	280275	Cable-Tie
695	693149	Screw (Ring Gear)	1058	275475	Operator's Manual
697	690372	Screw (Drive Cap)	1059	698516	Kit-Screw/Washer
703	691010	Clip	1070	691058	Screw (Flywheel Fan)
718	690959	Pin-Locating	1090	691293	Retainer-Brush
726	499612	Gear-Ring	1095	694013	Gasket Set-Valve
741	690980	Gear-Timing	1100	690973	Pivot-Rocker Arm
742	690328	Retainer-E Ring	1119	691183	Screw (Alternator)
750	696999	Screw (Oil Pump Cover)	1124	690988	Ø‡ Seal-O Ring (Fuel Transfer Tube)
783	693058	Gear-Pinion	1126	690991	Screw (Fuel Transfer Tube)
788	691039	Bracket-Fuel Pump	1127	690992	Screw (Float Bowl)
789	696576	Harness-Wiring	1128	690990	Screw (Carburetor Nozzle)
797	691029	Nut (Brush Retainer)	1267	698440	Latch-Blower Housing
797A	693167	Nut (Brush Retainer)(Serrated)	1329	446777-0026	Replacement Engine (Transfer 6 pin and Exhaust)
798	697890	Screw (Rocker Arm)	1330	273521	Repair Manual
801	691283	Cap-Drive	1342	699731	Extension-Fuel Transfer Tube
802	691286	Cap-End	1353	699725	Ø‡ Seal-O Ring (Fuel Transfer Tube Extension)
803	-----	Housing-Starter (Service with 691262 Starter Motor)			
842	691031	• Seal-Dipstick/Tube			
847	499602	Dipstick/Tube Assembly			
851	493880	Terminal-Spark Plug			
855	698072	Adapter-Air Cleaner			
865	691012	Cover-Air Guide			
865A	691014	Cover-Air Guide			
865B	691015	Cover-Air Guide			

NOTE: All component dimensions given in U.S. inches 1 inch = 25.4 mm

LIMITED WARRANTY ON CRAFTSMAN RIDING EQUIPMENT

For two (2) years from the date of purchase, if this Craftsman Riding Equipment is maintained, lubricated and tuned up according to the instructions in the owner's manual. Sears will repair or replace free of charge any parts that are found to be defective in material or workmanship according to the guidelines of coverage listed below. Sears will also provide free labor for these applicable warranted parts for the two full years. During the first 30 days of purchase, there will be no charges to service the product at your home for issues covered by this warranty. (See exclusions below). For your convenience, IN-HOME warranty service will still be available after the first 30 days of purchase, but a trip charge will apply. This charge will be waived if the Craftsman product is dropped off at an authorized Sears location. For the nearest authorized Sears location, please call 1-800-4-MY-HOME®. This warranty applies only while this product is within the United States.

THIS WARRANTY DOES NOT COVER:

- Expendable items which become worn during normal use, including but not limited to blades, spark plugs, air cleaners, belts, and oil filters.
- Standard Maintenance Servicing, oil changes, or tune-ups
- Tire replacement or repair caused by punctures from outside objects, such as nails, thorns, stumps, or glass.
- Repairs necessary because of operator abuse, including but not limited to, damage caused by towing objects beyond the capability of the riding equipment, impacting objects that bend the frame or crankshaft, or over-speeding the engine.
- Repairs necessary because of operator negligence, including but not limited to, electrical and mechanical damage caused by improper storage, failure to use the proper grade and amount of engine oil, failure to keep the deck clear of flammable debris, or failure to maintain the equipment according to the instructions contained in the owner's manual.
- Engine (fuel system) cleaning or repairs caused by fuel determined to be contaminated or oxidized (stale). In general, fuel should be used within 30 days of its purchase date.
- Normal deterioration and wear of the exterior finishes, or product label replacement.
- Riding equipment used for commercial or rental purposes.

LIMITED WARRANTY ON BATTERY

For ninety (90) days from date of purchase, if any battery included with this riding equipment proves defective in material or workmanship and our testing determines the battery will not hold a charge, Sears will replace the battery at no charge. During the first 30 days of purchase, there will be no charges to replace the battery at your HOME. After the first 30 days, for your convenience, IN-HOME warranty service will still be available but a trip charge will apply. This charge will be waived if the Craftsman product is dropped off at an authorized Sears location. For the nearest authorized Sears location, please call 1-800-4-MY-HOME®.

This battery warranty applies only while this product is within the United States.

This warranty gives you specific legal rights, and you may also have other rights, which vary, from state to state.
Sears, Roebuck and Co., Dept. 817WA, Hoffman Estates, IL 60179



CRAFTSMAN®