

REPAIR PARTS MANUAL
MODEL NO. 253710



HOW TO USE THIS MANUAL

This manual is designed to provide the customer with a means to identify the parts on his/her tractor when ordering repair parts. The illustrations may or may not represent the actual assemblies; therefore, it is not recommended to use this manual as a guide to assemble or disassemble the tractor. Some hardware and parts are drawn larger in order to more readily identify them.

Each tractor has its own model number.

The model number for your tractor can be found on the fender under the seat.

When ordering parts, always give the following information:

- Product - Lawn Tractor
- MODEL NUMBER - **253710**
- Part Number
- Part Description

TABLE OF CONTENTS

SCHEMATIC	3
ELECTRICAL.....	4-5
CHASSIS	6-7
DRIVE.....	8-9
ENGINE.....	10-11
STEERING	12
SEAT	13
MOWER DECK	14-15
MOWER LIFT.....	16
DECALS.....	17
TRANSAXLE BREAKDOWN	18-20
ENGINE BREAKDOWN.....	21-26
WARRANTY.....	BACK COVER

TRACTOR -- MODEL NUMBER 917.253710

SCHEMATIC

SCH12

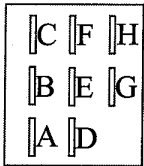
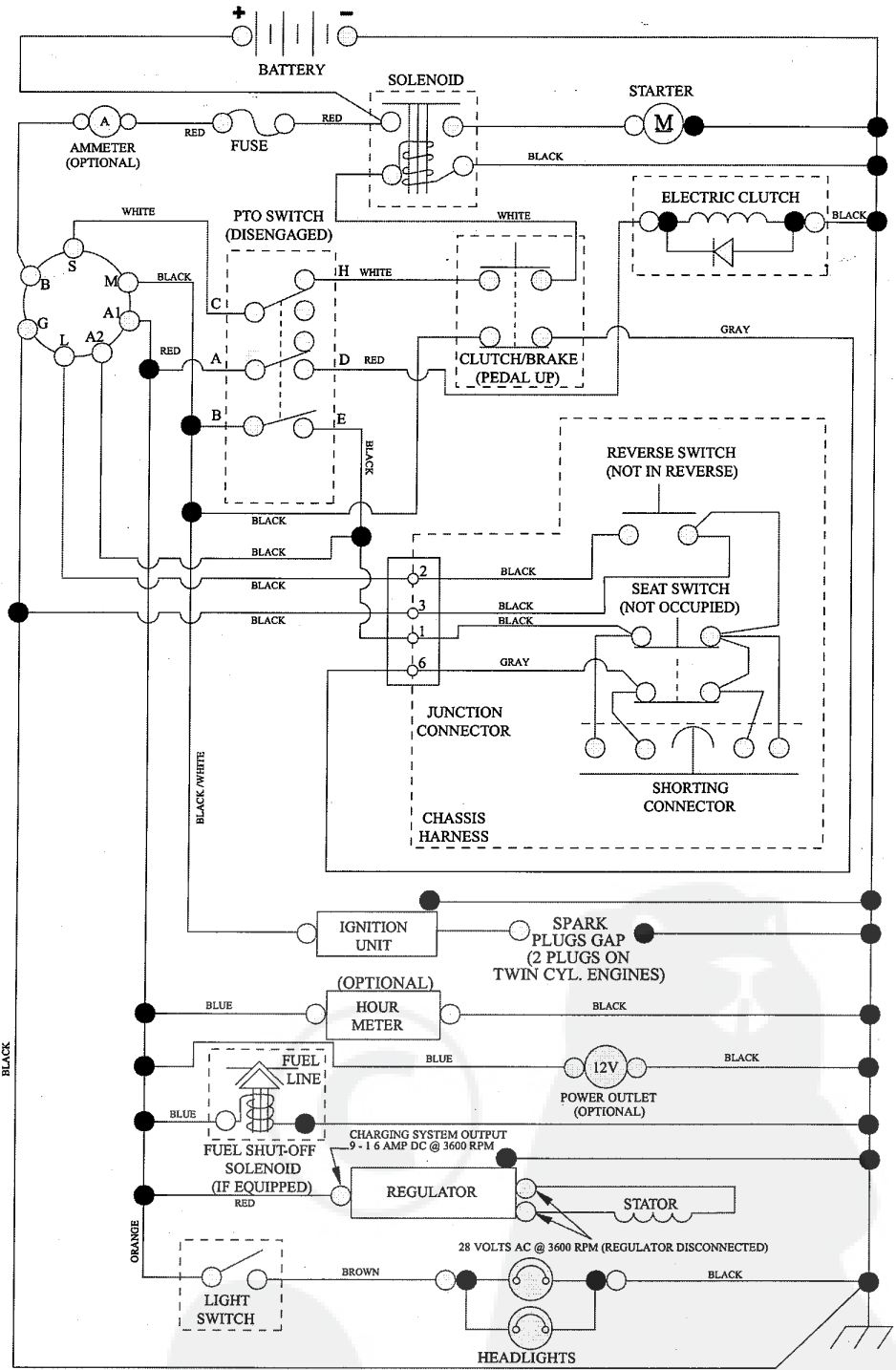

PTO SWITCH
(MATING SIDE)

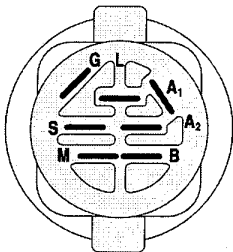

IGNITION SWITCH

POSITION	CIRCUIT "MAKE"
OFF	M+G+A1
RUN/OVERRIDE	B+A1
RUN	B+A1 L+A2
START	B + S + A1

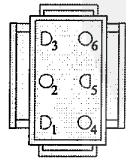

CHASSIS HARNESS
CONNECTOR
(MATING SIDE)

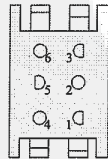

DASH HARNESS
CONNECTOR

WIRING INSULATED CLIPS
NOTE: IF WIRING INSULATED
CLIPS WERE REMOVED FOR
SERVICING OF UNIT, THEY
SHOULD BE RE-INSTALLED TO
PROPERLY SECURE YOUR
WIRING.

NON-REMOVABLE
CONNECTIONS

REMOVABLE
CONNECTIONS

TRACTOR -- MODEL NUMBER 917.253710

ELECTRICAL

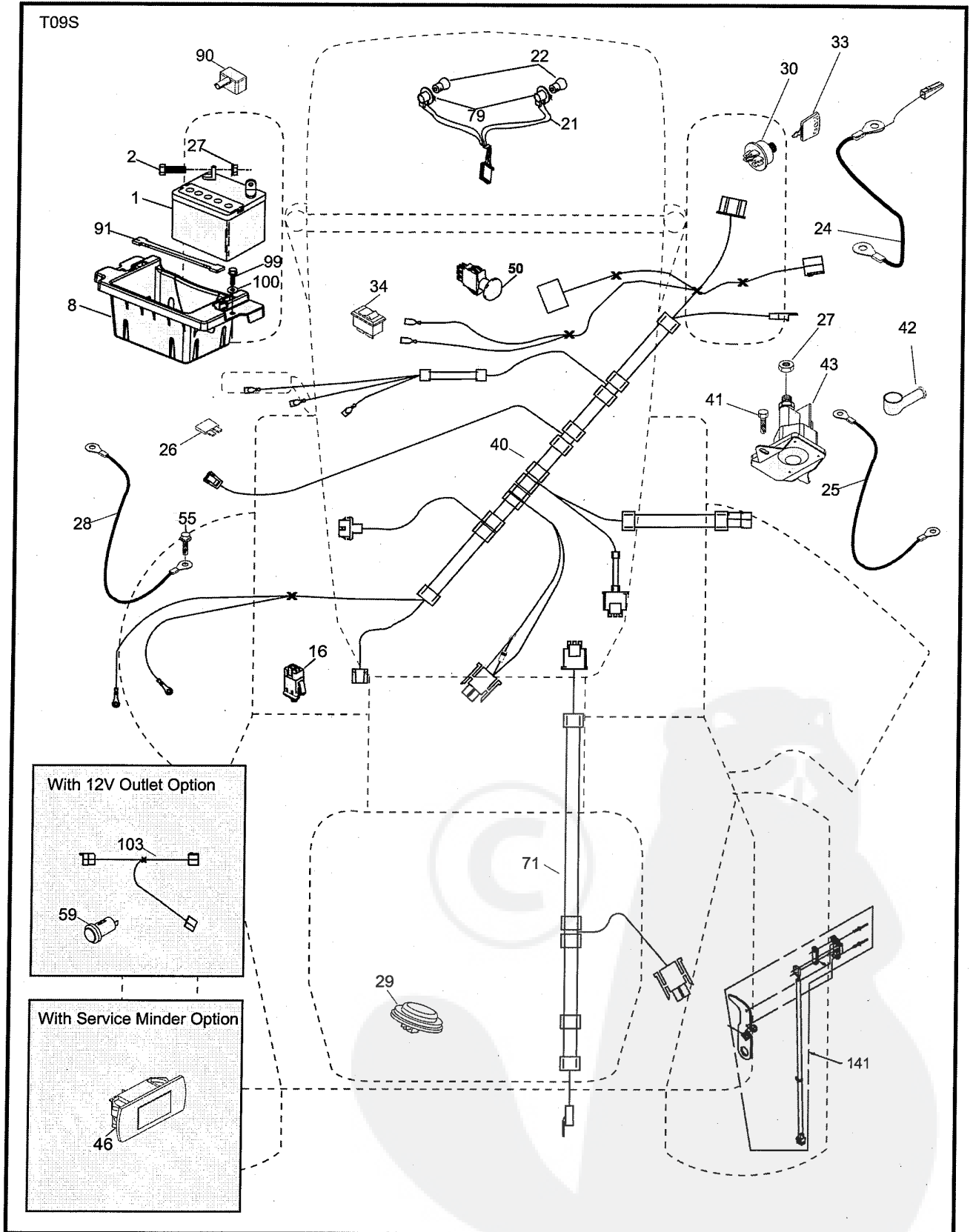

TRACTOR - - MODEL NUMBER 917.253710

ELECTRICAL

KEY NO.	PART NO.	DESCRIPTION
1	163465	Battery
2	74760412	Bolt Hex Head 1/4-20 x 3/4
8	186491	Box Battery
16	176138	Switch Interlock Push-In
21	400252	Harness Socket Light w/4152J
22	4152J	Bulb Light
24	400253	Cable Battery
25	412895	Cable Starter
26	175158	Fuse
27	73510400	Nut Keps Hex 1/4-20 unc
28	145491	Cable, Ground
29	401545	Switch, Seat
30	193350	Switch, Ign
33	411934	Key/Chain
34	110712X	Switch Light/Reset
40	401104	Harness Ign. Dash
41	17720408	Screw 1/4-20 x 1/2
42	131563	Cover, Terminal
43	192507	Solenoid
46	413931	Gauge Hourmeter
50	174652	Switch, PTO
55	17060512	Screw 5/16-18 x 3/4
71	194276	Harness Ignition
79	175242	Socket Asm. Bulb
90	400724	Cover Terminal Battery
91	190270	Strap Battery Mount Front
99	17670412	Screw Hexwsh Thdrol 1/4-20 x 3/4
100	19091416	Washer 9/32 x 7/8 x 16 Ga.
141	421225	Kit G700/G730 ROS Service

NOTE: All component dimensions given in U.S. inches
1 inch = 25.4 mm

TRACTOR -- MODEL NUMBER 917.253710

CHASSIS ASSEMBLY

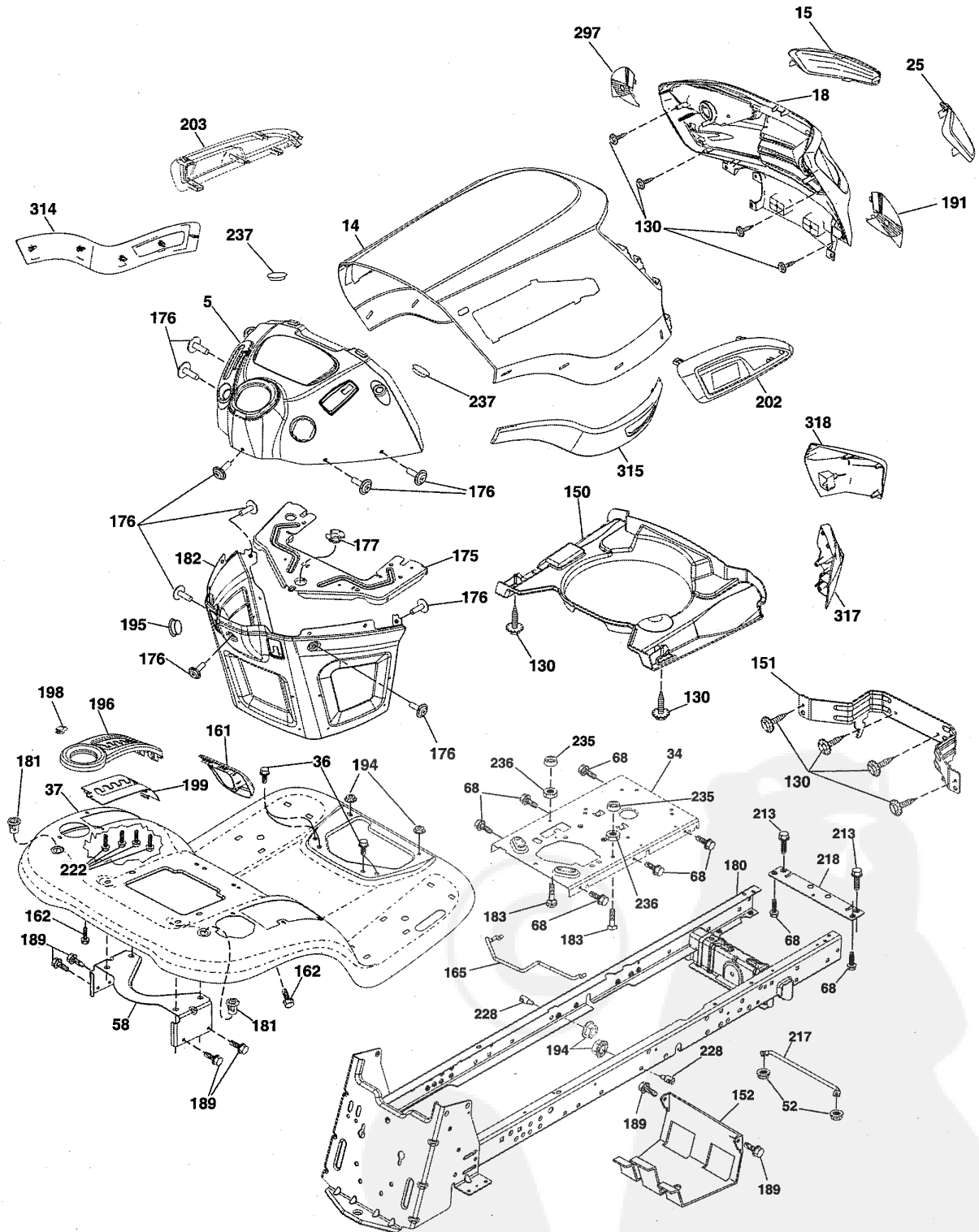

chassis-tex_PRED II GT_1

TRACTOR -- MODEL NUMBER 917.253710

CHASSIS ASSEMBLY

KEY NO.	PART NO.	DESCRIPTION
5	421811X428	Dash
14	421154X428	Hood
15	421493X599	Lens LH
18	423158	Grille, Assembly
25	421494X599	Lens RH
34	196125	Plate Engine
36	17060512	Screw 5/16-18 x 3/4
37	400009X428	Fender
52	73680500	Nut Lock 5/16-18
58	194314	Brack Support Fender
68	17490508	Screw Thdrol 5/16-18 x 1/2
130	416358	Screw #10 x 0.750
150	199411	Duct Heat Hood
151	196332	Bracket Pivot
152	199535	Shield Browning/Debris
161	193097X428	Window Fuel
162	142432	Screw Hex Wsh Hi-Lo 1/4 x 1/2
165	196826	Support Tank Rear
175	196304	Crossmember
176	400776	Screw
177	195227	Bushing Steering
180	195477	Chassis
181	193102X428	Bushing Mtg. Fender Crgo.
182	406859	Dash Lower
183	74780520	Bolt Fin Hex 5/16-18 unc x 1-1/4

KEY NO.	PART NO.	DESCRIPTION
189	17000512	Screw 3/8-16 x 3/4
191	425407	Insert Reflective RH
194	73900500	Nut Lock Hex Flange 5/16-18
195	401556X428	Plug Hole Dash
196	196379X428	Console Asm. Deck Lift
198	197300X505	Indicator Deck Lift
199	196377	Plate Deck Lift
202	423175	Vent Side Hood RH
203	423174	Vent Side Hood LH
213	74760512	Bolt 5/16-18 unc x 3/4
217	409167	Rod Pivot Hood
218	196395	X-Piece Hood Stop
222	137729	Screw 1/4-20 x 5/8
228	195161	Stud Fastener
235	406129	Spacer Fender
236	73930500	Nut 5/16-18 unc
237	403704	Plug Mount Cargo
297	425406	Insert Reflective LH
314	426570	Trim Side LH
315	426571	Trim Side RH
317	421257X428	Cap Corner RH
318	421258X428	Cap Corner LH

NOTE: All component dimensions given in U.S. inches
1 inch = 25.4 mm

TRACTOR -- MODEL NUMBER 917.253710

GROUND DRIVE

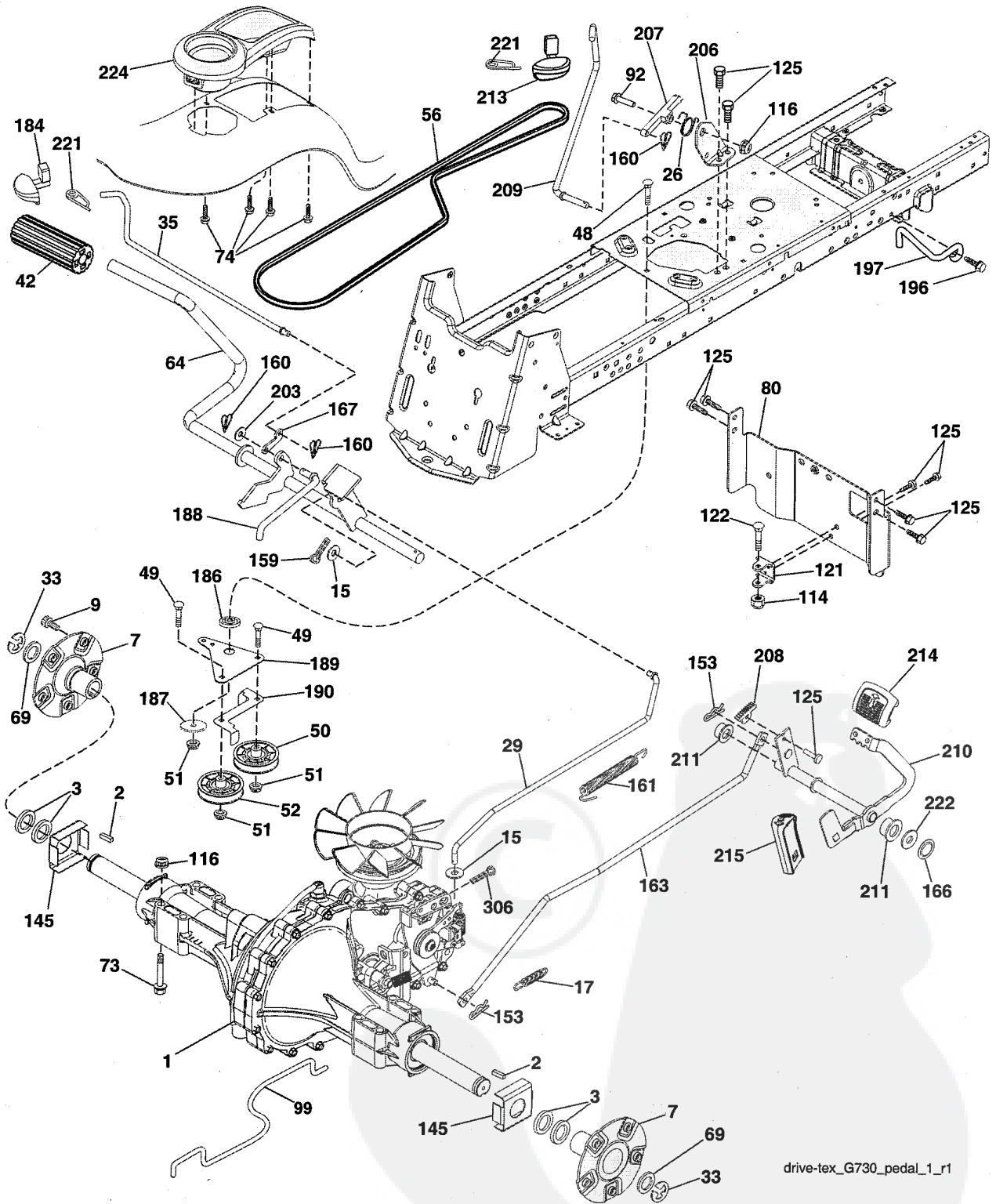

drive-tex_G730_pedal_1_r1

TRACTOR - - MODEL NUMBER 917.253710

GROUND DRIVE

KEY NO.	PART NO.	DESCRIPTION	KEY NO.	PART NO.	DESCRIPTION
1	-----	Transaxle, Hydro G7-BCBB-1XDC-1FCA	159	76020412	Pin Cotter 1/8 x 3/4
2	7070E	Key 1/4 x 2.5	160	169484	Retainer Clip
3	7563R	Washer Thrust Axle Hardened	161	105709X	Spring, Return, Clutch
7	199837	Hub Asm. Wheel	163	418185	Rod Pedal Control
9	140080	Bolt Hub Wheel	166	197290	Nut Push .625
15	19131316	Washer 13/32 x 13/16 x 16 Ga.	167	405257	Latch Brake Parking
17	197296	Spring, Brake	184	196439X505	Handle Parking Brake
26	199679	Spring Return Cruise	186	194321	Spacer Retainer
29	418186	Rod, Brake	187	19133210	Washer
33	12000053	Ring E	188	194323	Link Clutch Ground Drive
35	199591	Rod, Brake, Park	189	407504	Bellcrank Ground Drive
42	8883R	Cover, Foot Pedal	190	407505	Keeper Bellcrank Ground Drive
48	72110612	Bolt Carr Sh 3/8-16 x 1-1/2 Gr. 5	196	17000616	Screw 3/8-16 x 1
49	72110614	Bolt	197	199769	Bracket Clutch Anti-Rotation
50	194327	Pulley Idler Flat	203	19111116	Washer 11/32 x 11/16 x 16 Ga.
51	73900600	Lock Nut 3/8-16	206	197867	Bracket Mount Latch Cruise
52	194326	Idler V-Groove 910" Offset	207	197868	Latch Control Cruise
56	420807	V-Belt, Drive	208	197869	Gear Sector Control Cruise
64	197865	Shaft Asm. Pedal Brake Control	209	199592	Rod Control Cruise
69	123800X	Washer 1-1/32 x 1-5/8 x 16 Ga.	210	197860	Rocker Asm. Pedal Control
73	74490548	Bolt Hex 5/16-18 x 3 Gr. 5	211	120183	Bearing Nylon
74	142432	Screw 1/4 x 1/2	213	196441X428	Knob Control Cruise
80	418184	Strap Torque	214	421263	Pedal Forward
92	74760520	Bolt 5/16-18 x 1/2	215	197301X428	Pedal Reverse
99	418188	Spring Bypass	221	403187	Retainer Spring Clip Handle
114	73800500	Nut Lock Hex W/Ins. 5/16-18 unc	222	79212010	Washer 21/32 x 1-1/4 x 10 Ga.
116	73900500	Nut Lock Hex Flange 5/16-18	224	193099X428	Console Toolbox
121	175611	Bracket Strap Torque	306	76020416	Pin Cotter
122	72010520	Bolt 5/16-18 x 2.50			
125	17000512	Screw 5/16-18 x 3/4			
145	163168	Washer Axle Flange			
153	4497H	Retainer Spring			

NOTE: All component dimensions given in U.S. inches
1 inch = 25.4 mm

TRACTOR -- MODEL NUMBER 917.253710

ENGINE

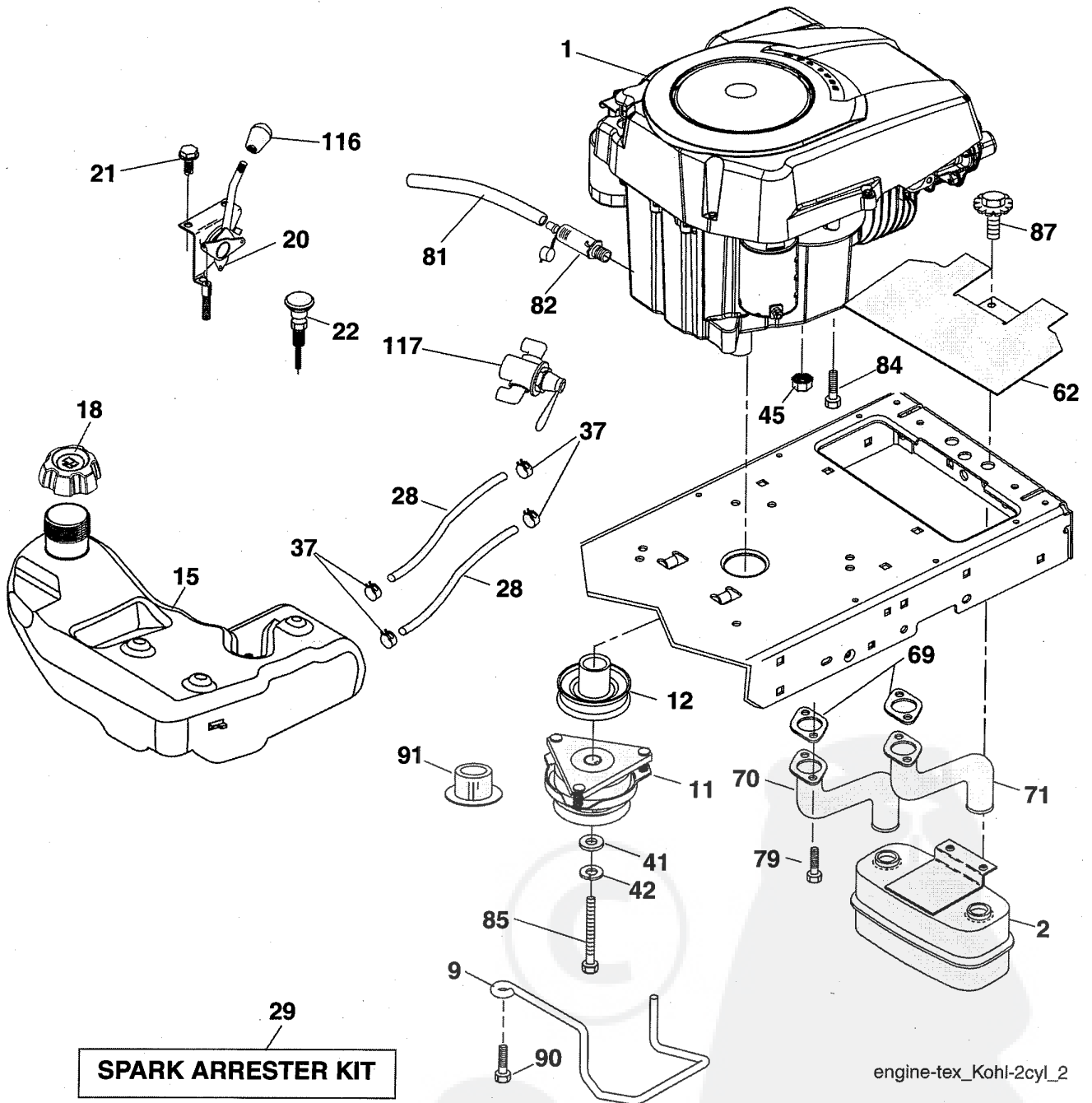

TRACTOR -- MODEL NUMBER 917.253710

ENGINE

KEY NO.	PART NO.	DESCRIPTION
1	-----	Engine Kohler Model No. SV735 -0019 (See Engine Breakdown)
2	149723	Muffler
9	408667	Keeper Belt Engine
11	179335	Clutch Electric
12	194343	Pulley Engine
15	422804	Tank Fuel 4.0
18	195951	Cap Asm
20	426184	Control Throttle
21	416358	Screw 10 x .750 BOS Thread
22	187767X428	Control Choke
28	8543R	Fuel Line
29	137180	Spark Arrester Kit
37	123487X	Clamp Hose
41	126197X	Washer 1-1/2 OD x 15/32 ID x .250
42	10040700	Washer Lock 7/16
45	73510400	Nut Keps Hex 1/4-20 unc
62	146629	Shield Heat Muffler
69	-----	Gasket (Order from Eng. Mfgr.)
70	146699	Tube Exhaust LH
71	146700	Tube Exhaust RH
79	192334	Screw 5/16-18 x 3/4
81	148456	Tube Drain Oil Easy
82	181654	Plug Drain Oil
84	17120616	Screw 3/8-16 x 1
85	179953	Bolt Hex 7/16-20 x 3.75 Gr. 5
87	198239	Bolt 5/16-18 unc x 1 w/Sems
90	17000616	Screw 3/8-16 x 1
91	187495	Bushing
116	423109X659	Knob Oval Tapered 3/8-16
117	420828	Value Fuel Reserve

NOTE: All component dimensions given in U.S. inches
1 inch = 25.4 mm

For engine service and replacement parts, call the toll free
number for your engine manufacturer listed below:

Kohler Co. 1-800-544-2444

TRACTOR -- MODEL NUMBER 917.253710

STEERING ASSEMBLY

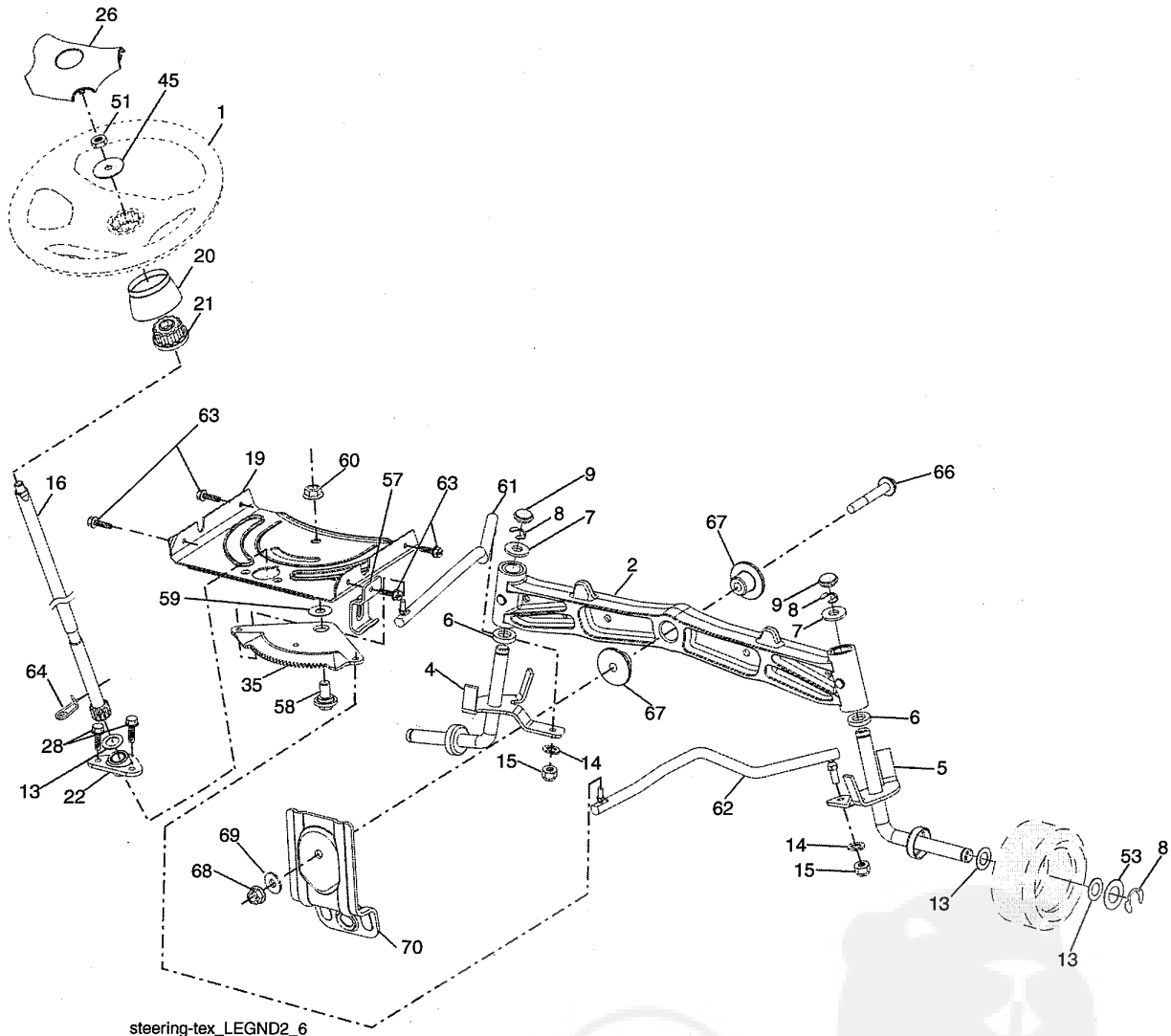

steering-tex_LEGND2_6

KEY NO.	PART NO.	DESCRIPTION	KEY NO.	PART NO.	DESCRIPTION
1	414851X659	Wheel, Steering	51	73940800	Nut Hex Jam Toplock 1/2-20 unf
2	195968	Axle Asm., Front	53	188967	Washer Hardened .793 x 1.637 x .060
4	403089	Spindle Asm., LH	57	197246	Bracket Upstop
5	403090	Spindle Asm., RH	58	194747	Bolt Shoulder Sector Pivot CFM
6	6266H	Bearing, Race Thrust Harden	59	194748	Washer Thrust Sector Steering
7	121748X	Washer 25/32 x 1-5/8 x 16 Ga.	60	73971000	Nut Flange Lock 5/8-11
8	12000029	Ring, Clip #T5304-75	61	194740	Draglink, LH
9	184946X505	Cap, Spindle	62	194741	Draglink, RH
13	121749X	Washer 25/32 x 1-1/4 x 16 Ga.	63	17000512	Screw 5/16-18 x 3/4
14	STD551137	Washer Lock Hvy Hlcl Spr 3/8	64	199849	Retainer Clip Spring Steering
15	73540600	Nut, Crown Lock 3/8-24 unf	66	71020748	Bolt Hex Fghd 7/16-14 x 3 Serr
16	194746	Shaft Steering	67	194737	Bushing PM Front Axle
19	194729	Plate Steering	68	73900700	Nut Lock Flange 7/16-14 Gr. 5
20	199676X428	Boot, Steering	69	199162	Washer 1.5 x .505 x .118
21	186737	Adapter, Wheel Steering	70	196197	Bracket Deck Susp. Front
22	194845	Bushing, Strg. Blk			
26	414852X659	Insert, Wheel Steering			
28	17000612	Screw 3/8-16 x 3/4			
35	194732	Gear, Sector Plate			
45	19183812	Washer 9/16 x 2-3/8 x 12 Ga.			

NOTE: All component dimensions give in U.S. inches
1 inch = 25.4 mm

TRACTOR -- MODEL NUMBER 917.253710

SEAT ASSEMBLY

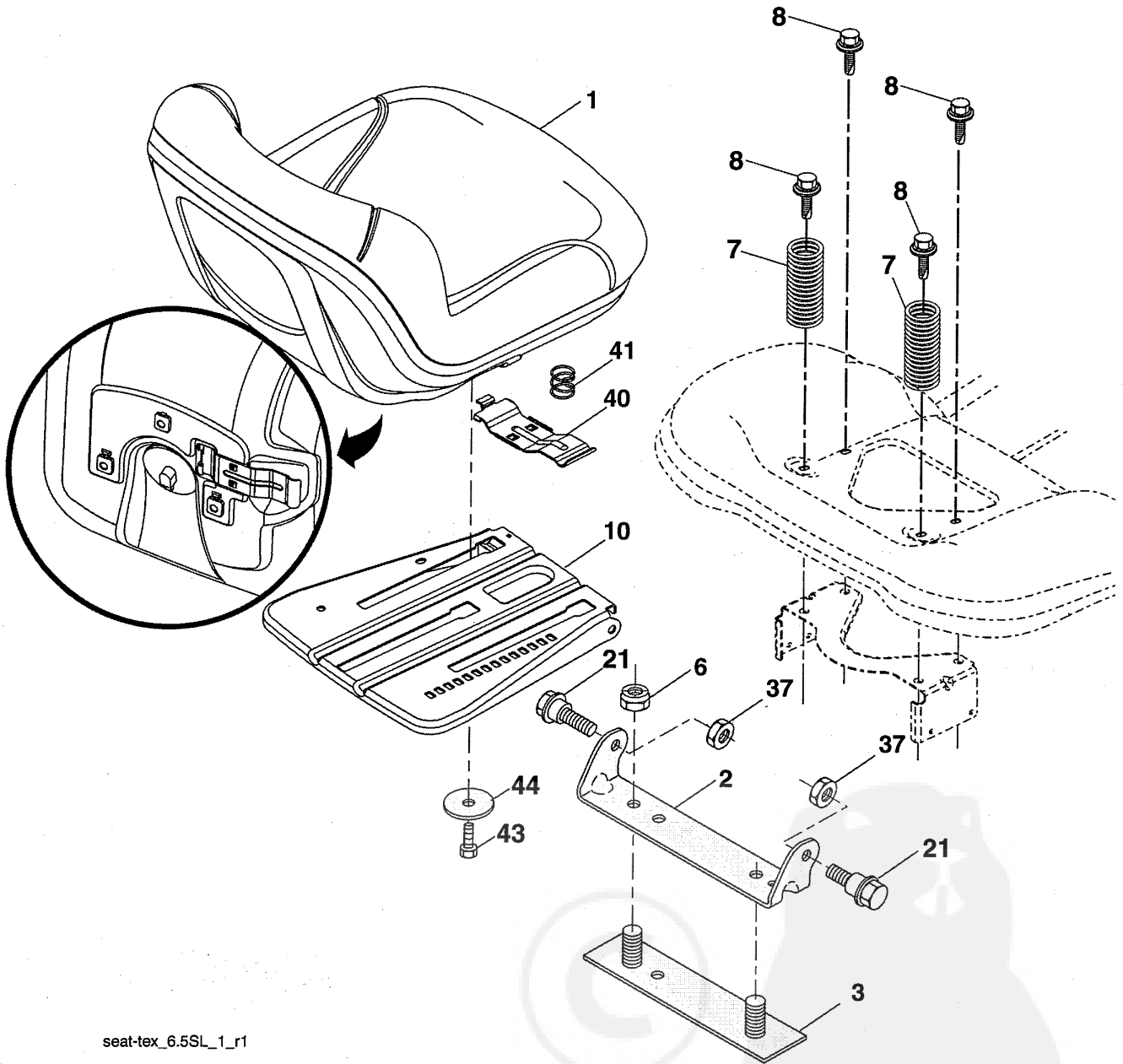

seat-tex_6.5SL_1_r1

KEY NO.	PART NO.	DESCRIPTION
1	423810	Seat
2	180166	Bracket Pivot Fender
3	140675	Strap, Asm Fender
6	STD541437	Nut, Lock w/Ins. 3/8-16 unc
7	124181X	Spring, Seat Cprsn
8	171877	Bolt 5/16-18 unc x 3/4 w/Sems
10	196977	Pan, Seat
21	171852	Bolt, Shoulder 5/16-18
37	STD541431	Nut, Lock 5/16-18 unc

KEY NO.	PART NO.	DESCRIPTION
40	197661	Handle Slide Seat
41	198200	Spring Latch Seat
43	74760612	Bolt 3/8-16 unc x 3/4
44	19133812	Washer 13/32 x 2-3/8 x 12 Ga.

NOTE: All component dimensions give in U.S. inches
1 inch = 25.4 mm

TRACTOR -- MODEL NUMBER 917.253710

MOWER DECK

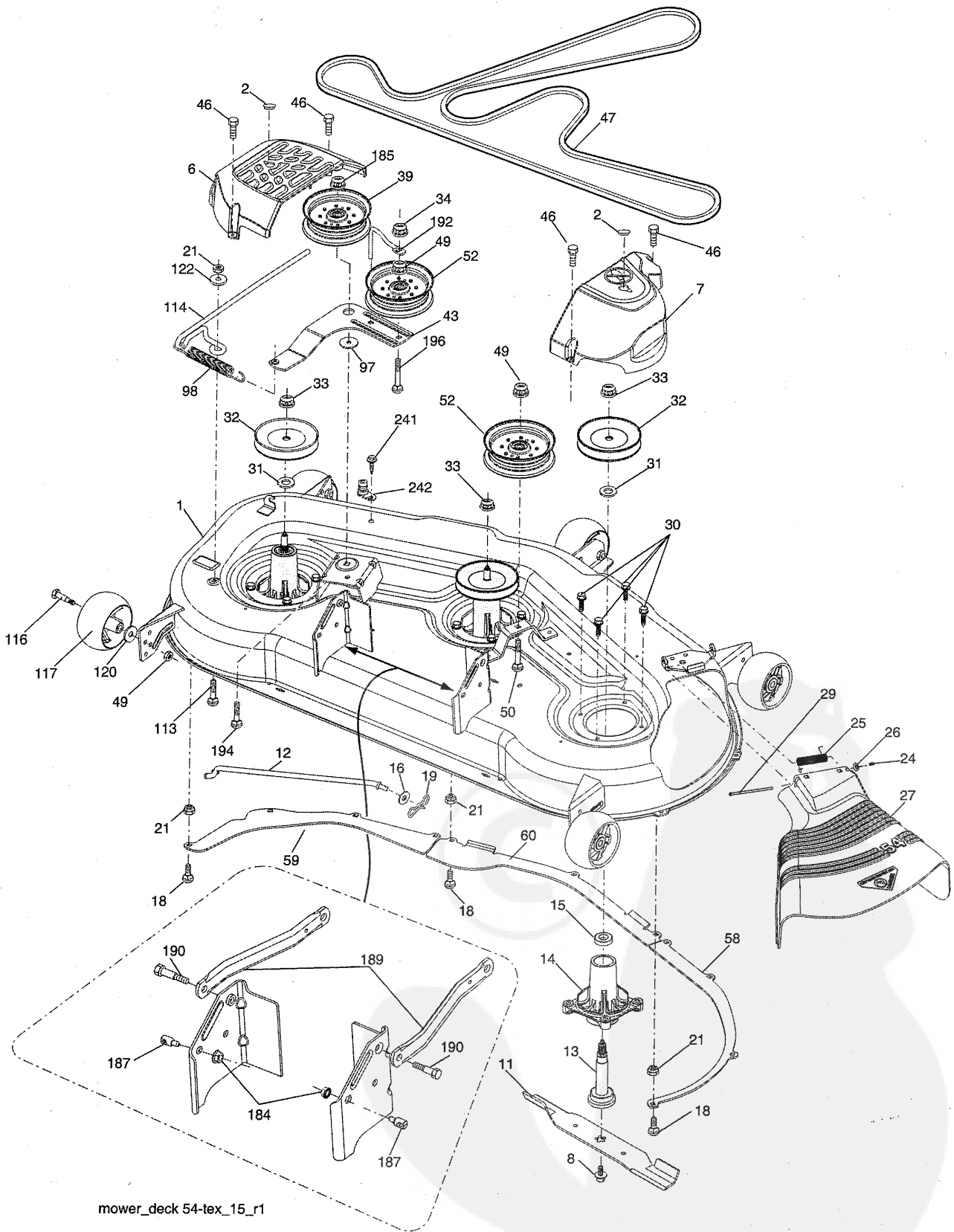

mower_deck 54-tex_15_r1

TRACTOR -- MODEL NUMBER 917.253710

MOWER DECK

KEY NO.	PART NO.	DESCRIPTION
1	195632X613	Deck Weldment Mower
2	178345	Plug Hole Mandrel
6	196066	Cover Mandrel LH
7	197181	Cover Mandrel RH
8	193003	Bolt/Washer Asm. 7/16-20 unf
11	187256	Blade Bagging
12	400337	Rod Anti Sway
13	187291	Shaft Asm. w/Lower Bearing
14	187281	Housing, Mandrel
15	110485X	Bearing, Ball, Mandrel
16	19131312	Washer 13/32 x 13/16 x 12 Ga.
18	72140505	Bolt RdHd 5/16-18 unc x 5/8
19	194208	Pin Cotter 5/16 Bow Tie Lock
21	73680500	Nut, Crownlock 5/16-18 unc
24	105304X	Cap Sleeve
25	178102	Spring, Torsion
26	110452X	Nut, Push
27	187257X428	Deflector Shield
29	131491	Rod, Hinge
30	173984	Screw, Thdroll Washer Head
31	426210	Spacer Mandrel
32	153535	Pulley, Mandrel
33	400234	Nut, Flg. Top Lock
34	73680600	Nut
39	197380	Pulley, Idler
43	196065	Arm, Idler
46	137729	Screw, Thdroll. 1/4-20 x 5/8
47	196103	V-Belt, Mower
49	73900600	Nut, Lock Flg. 3/8-16 unc
50	72110616	Bolt, Carr. 3/8-16 x 2
52	197379	Pulley Idler
58	187342	Baffle Right
59	187344	Baffle Left
60	187607	Baffle Center
97	178515	Washer Hardened
98	196105	Spring Drive
113	72110508	Bolt Rdhd Sqnk 5/16-18 x 3/4
114	187556	Rod Tension Relief
116	193406	Bolt, Shoulder
117	174873	Gauge Wheel
120	19132012	Washer 13/32 x 1-1/4 x 12 Ga.
122	187557	Bushing Tension Relief
184	73900500	Nut Lock Flange 5/16-18
185	73900700	Nut Lock Flange 7/16-14 Gr. 5
187	195161	Stud Fastener w/"D" Anti-Rotation
189	195185	Arm Susp. Mower Rear
190	196539	Bolt Shoulder
192	198468	Keeper Belt Idler
194	72140716	Bolt Carr Sqnk 3/8-16 x 2-1/4
196	72140620	Bolt RdHd 3/8-16 unc x 2-1/2 Gr. 5
241	152927	Screw
242	415598	Washout Port
--	187292	Mandrel Asm. Service (Includes Key Nos. 13-15 and 33)
--	416405	Coupling Quick Connect
--	427610	Replacement Mower, Complete

NOTE: All component dimensions given in U.S. inches
1 inch = 25.4 mm

TRACTOR -- MODEL NUMBER 917.253710

LIFT ASSEMBLY

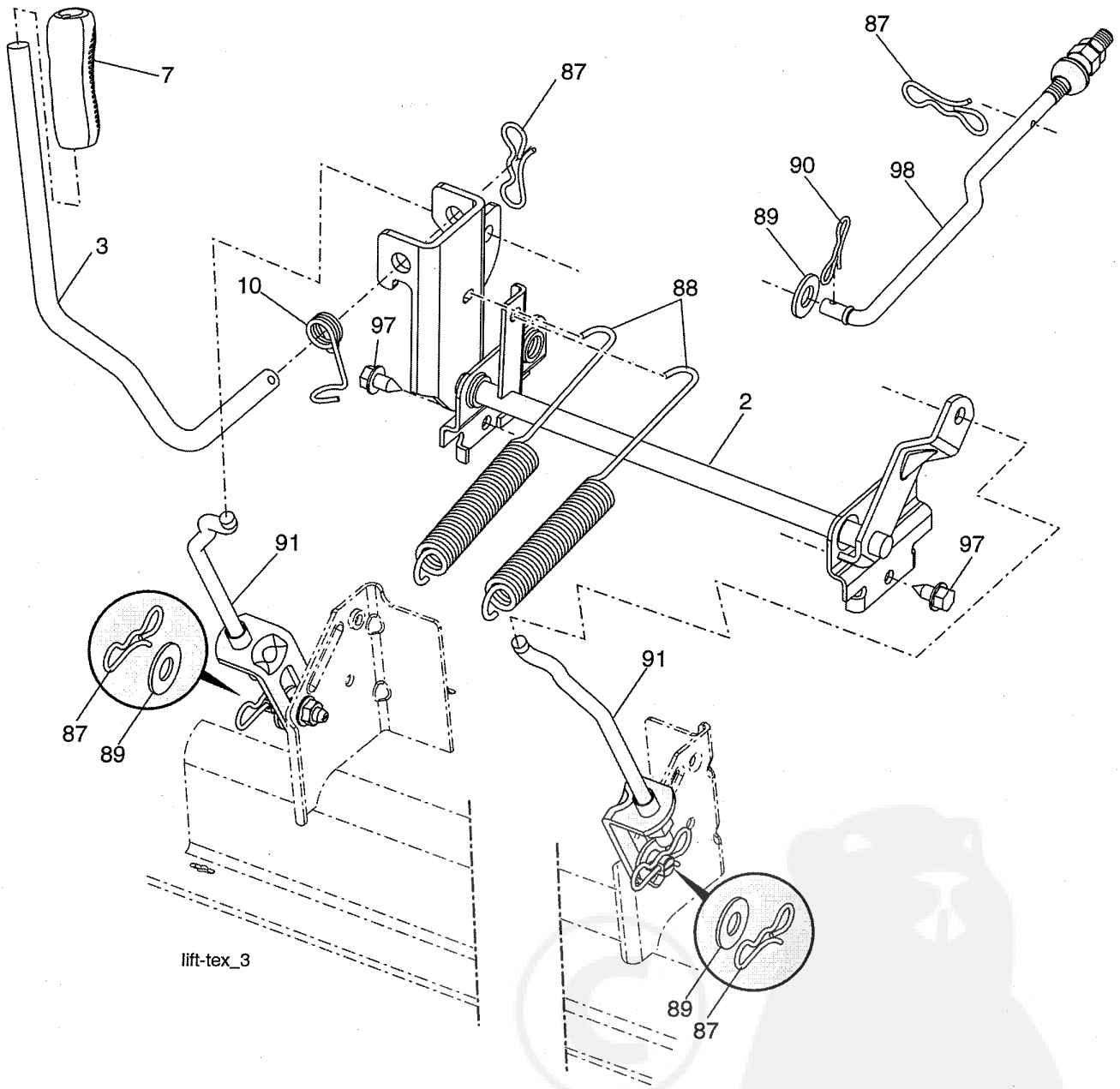

lift-tex_3

KEY NO.	PART NO.	DESCRIPTION
2	195223	Shaft Asm., Lift
3	195230	Lever Asm., Lift RH
7	196492X428	Grip, Lever
10	196314	Spring Torsion
87	194209	Pin Cotter 7/16 Bow Tie Lock
88	195304	Spring Lift Assist
89	19191912	Washer Clear Zinc
90	194208	Pin Cotter 5/16 Bow Tie Lock

KEY NO.	PART NO.	DESCRIPTION
91	403407	Link Lift Asm. Rear
97	17000612	Screw 3/8-16 x .75 R.Z
98	195264	Link Asm. Susp. Front Mower

NOTE: All component dimensions give in U.S. inches
1 inch = 25.4 mm

TRACTOR -- MODEL NUMBER 917.253710

DECALS

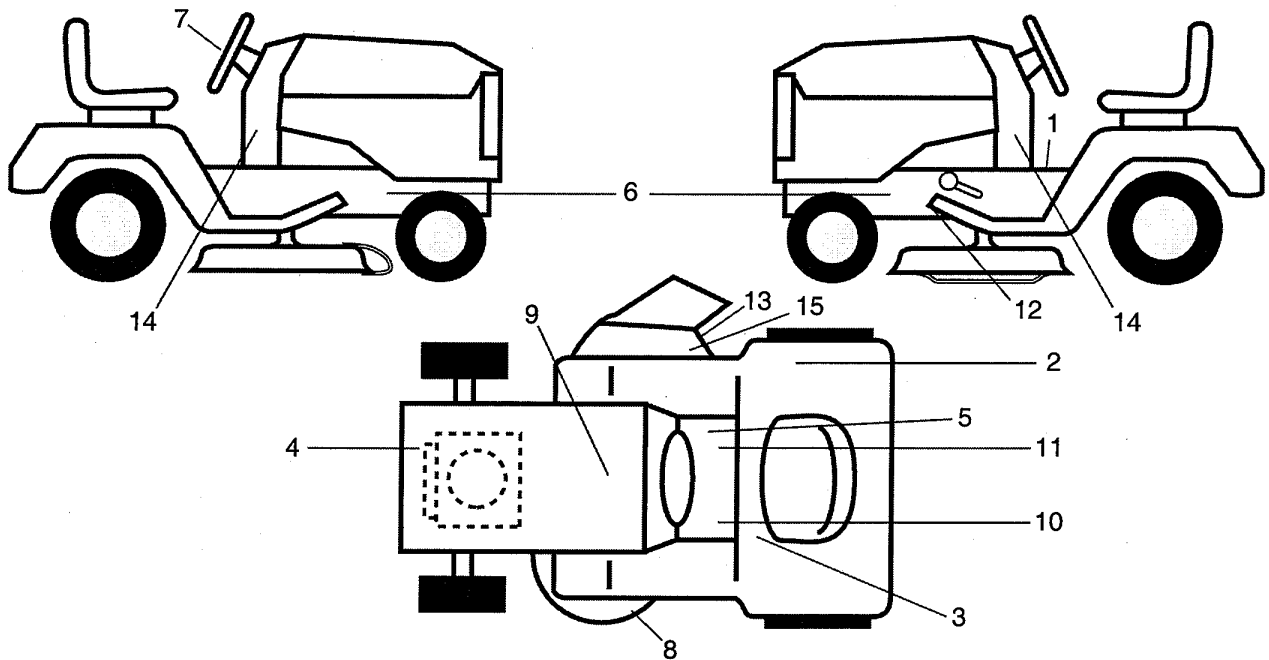

KEY PART NO. NO.

KEY NO.	PART NO.	DESCRIPTION
1	400389	Decal, Oper./Warng
2	180432	Decal, Fender 100 DB/CE
3	426209	Decal, Warn. Reserve Fuel
4	196841	Decal, Warning Engine Symbols
5	178302	Decal, Operator Cruise Symbols
6	159736	Decal, Chassis Hot Muffler
7	422885	Decal, Steering
8	198785	Decal, Mower Schematic
9	145005	Decal, Battery Dnge/Poi
10	159737	Decal, Brake/Clutch Symbol
11	140837	Decal, Saddle Brake Parking
12	199135	Decal, Mower V-Belt Schematic
13	182166	Decal, Cutfinger CE

KEY PART NO. NO.

KEY NO.	PART NO.	DESCRIPTION
14	426193	Decal, Dash Lower
15	196357	Decal, Deflector Wrn Cutfinger Symbol
--	166960	Decal Bypass
--	162598	Decal Drawbar Load Limit
--	193279X428	Pad Footrest RH
--	193101X428	Pad Footrest LH
--	427593	Manual, Operator's (Euro)
--	427594	Manual, Operator's (Scand)
--	427595	Manual, Operator's (E-Bloc)
--	427596	Manual, Operator's (Baltic)
--	427597	Manual, Parts

WHEELS & TIRES

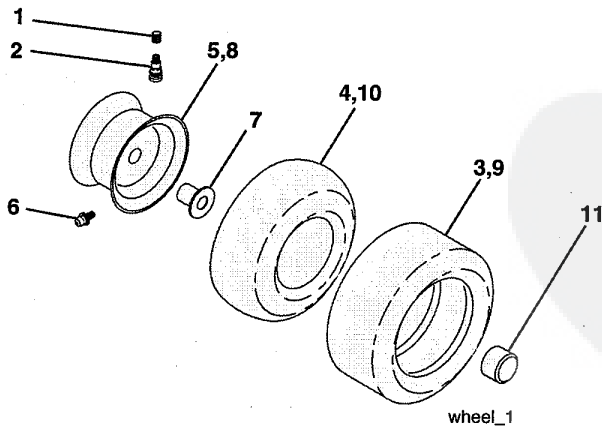

KEY PART NO. NO.

KEY NO.	PART NO.	DESCRIPTION
1	59192	Cap, Valve, Tire
2	65139	Stem, Valve
3	106228X613	Rim Assembly, Front
4	8134H	Tube, Front (Service Item Only)
5	106230X	Tire, Front
6	278H	Fitting, Grease (Front Wheel Only)
7	9040H	Bearing, Flange (Front Wheel Only)
8	104757X428	Cap, Axle (Front Wheel Only)
9	105588X	Tire, Rear
10	7154J	Tube, Rear (Service Item Only)
11	106277X613	Rim Assembly, Rear
--	144334	Sealant, Tire (10 oz. Tube)

NOTE: All component dimensions give in U.S. inches
1 inch = 25.4 mm

TRACTOR - - MODEL NUMBER 917.253710
HYDRO GEAR TRANSAXLE - - MODEL NUMBER G7-BCBB-1XDC-1FCA

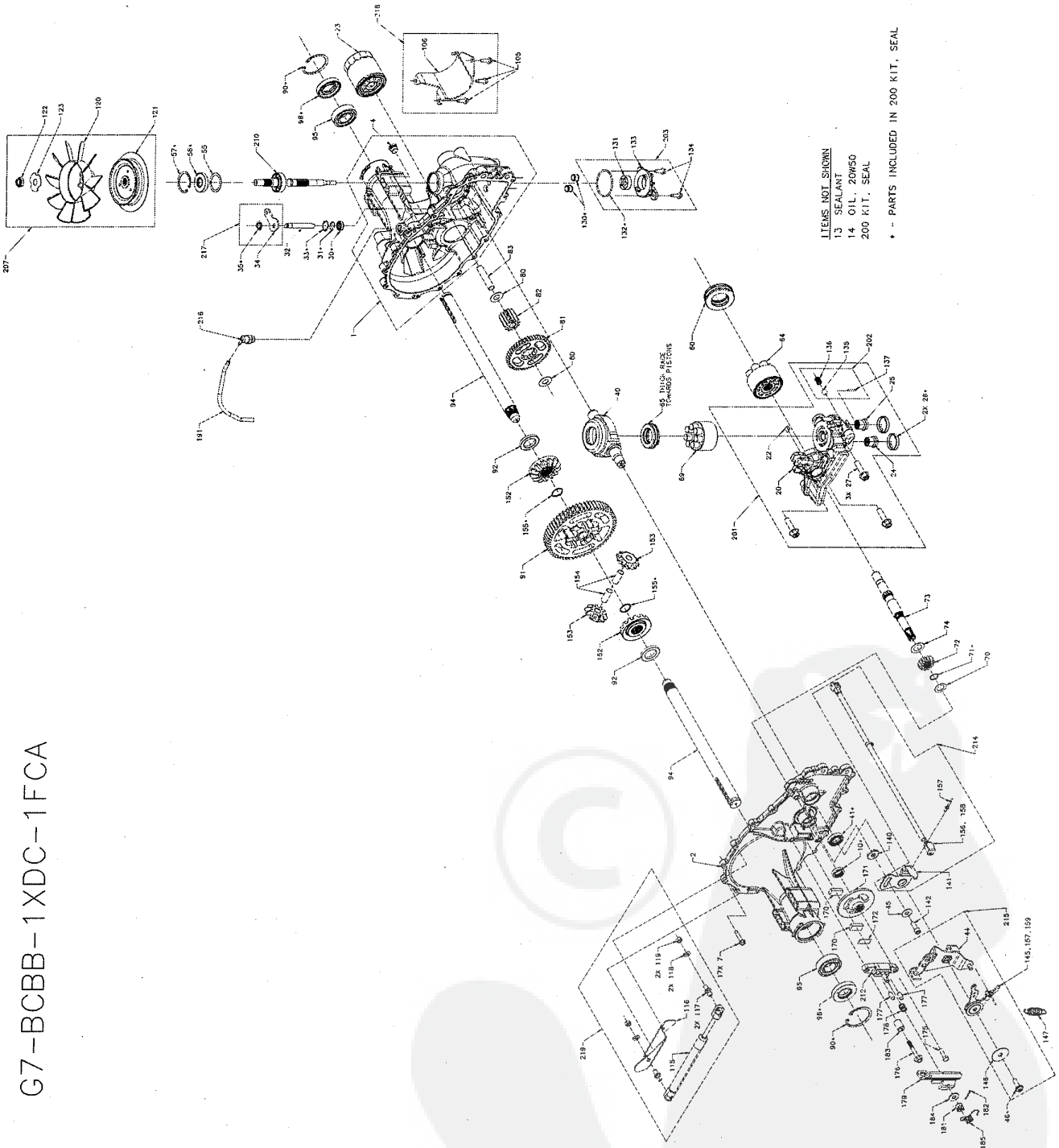

ITEMS NOT SHOWN
 13 SEALANT
 14 OIL ZORGO
 200 KIT, SEAL

* - PARTS INCLUDED IN 200 KIT, SEAL

G7-BCBB-1XDC-1FCA

TRACTOR - - MODEL NUMBER 917.253710

HYDRO GEAR TRANSAXLE - - MODEL NUMBER G7-BCBB-1XDC-1FCA

KEY NO.	PART NO.	DESCRIPTION	KEY NO.	PART NO.	DESCRIPTION
1	421183 (4)	Kit, Housing Main Plug 9/16-18 (Metal) Housing, Main Pin, .25 X .375 Bushing, .624 X .719 X .562 Bushing, .865 X .985 X .790 Bearing, Flange 1.0 X 1.376 X .99	140	421210	SpacEr, .320 X 1.005 X .179
2	421184	Kit, Housing, Side Housing, Side Bushing, .624 X .729 X .562 Bushing, .865 X .985 .790 Bearing, Flange 1.0 X 1.376 X .99	142	421211	Shcs 5/16-24 X 1 Patch
4	170434	Plug 9/16-18 (Metal)	147	421212	Spring, Extention Rtn-44 Lbs
7	170356	Hfhcs 1/4-20 X 1.25"	152	421213	Gear, Bevel 14t Spline Id
10	417764	Seal, Lip .625 X 1.0	153	421214	Gear, Bevel 10t
13	178322	Tube, Sealant	154	421215	Pin, .499 X 1.20
14		Oil, 20w50	155	421216	Ring, Spiral Ret .875
22	421185	Plate, Bypass	170	142883	Puck, Brake
23	421186	Filter, Oil	171	421217	Rotor, Brake
26	421187	Seal, Plug 1.250 X .250	172	142882	Plate, Puck
27	421188	Hfhcs 3/8-16 X 1.5 (Patch)	175	142892	Bolt, Hex Head 1/4-20 X 1 w/Patch
30	421189	Seal, Lip .375 X .75 X .25	176	170410	Bolt, Hex Head 1/4-20 X 2 w/Patch
31	421190	Ring, Retaining .375 External	177	170409	Pin, Brk .31 X .73 Plated
32	421191	Rod, Bypass	178	170417	Spring, Comp Brake Anti-Drag
33	421192	Ring, Retaining .750 Internal	179	178330	Arm, Brake
35	421193	Retaining Ring	181	170415	Nut, Castle 5/16-24 PI
40	170354	Trunnion, Swashplate	182	170416	Pin, Cotter 3/32 X 3/4
41	170363	Seal, Lip 18 X 32 X 7	183	170411	Spacer, .26 X .57 X .87
45	142884	Washer, .24 X .88 X .06	184	142884	Washer, .27 X .88 X .12
46	421194	Twhcs 5/16-24 X 1.00 (Patch)	185	178335	Spring, Brake Arm Bias
55	170360	Washer, 1.23 X 1.56 X .04	191	421218	Tube .16 X .28 X 9.25
56	170361	Seal, Lip 17 X 40 X 7	200	421219	Kit, Seal Pin .25 X .375
57	169870	Ring, Retaining 1.575 Internal	(10)		Seal, Lip .625 X 1.0
60	421195	BearIng, Thrust	(26)		Seal, Plug 1.250 X .250
64	421196	Assembly, Block, Block Spring Seat Washer Piston	(30)		Seal, Lip .375 X .75 X .25
65	173159	Bearing, Thrust Ball 30 X 52 X 13	(31)		Ring, Retaining .375 External
69	421197	Assembly, Block, Block Spring Seat Washer, Piston	(33)		Ring, Retaining .750 Internal
70	170404	Washer, .63 X 1.0 X .05	(35)		Ring, Retaining .375 External
71	170405	Ring, Retaining .625 External	(41)		Seal, Lip 18 X 32 X 7
72	421198	Gear, 14t	(46)		Twhcs 5/16-24 X 1.00 (Patch)
73	421199	Shaft, Motor	(56)		Seal, Lip 17 X 40 X 7
74	170433	Washer, .72 X 1.16 X .04	(57)		Ring, Retaining 1.575 Internal
80	170418	Washer, .5 X 1.0 X .03	(71)		Ring, Retaining .625 External
81	421200	Gear, 45t	(90)		Ring, Retaining 2.06 Internal
82	421201	Gear, 11t	(96)		Seal, Lip 25 X 52 X 10 Tc (Gray)
83	170394	Pin, Jackshaft	(130)		Tube, Connecting
90	169539	Ring, Retaining 2.06 Internal	(132)		O-Ring, -137, .103 X 2.050
91	421202	GEar, 60t	(155)		Ring, Spiral Ret .875
92	421203	Spacer, 1.04 X 1.65 X .22	201	421220	Kit, Center Section, Lh, Chrg
94	421204	Shaft, Axle 1.00 X 14.48, Keyed	20		Center Section, Lh, Chrg
95	169535	Bearing, Ball 1.0 X 52 X 15	(22)		Plate, Bypass
96	161157	Seal, Lip 25 X 52 X 10 Tc (Gray)	24		Check Plug
120	421205	Fan, Recess 7.0 (10 Blade)	25		Check Plug
121	422126	Pulley 3.86 Inch	(26)		Seal, Plug 1.250 X .250
122	150794	Hex Lock Nut 1/2-20 (With Patch)	(27)		Hfhcs 3/8-16 X 1.5 (Patch) Brg, Jrnl
123	199658	Washer, Slotted	135		Ball, Steel 7/16"
130	421207	Tube, Connecting	136		Spring, Relief .42 X .75
131	169531	Geroter Assembly (1.9cc/Rev)	137		Pin, Spring .125 X .875
132	421208	O-Ring, -137, .103 X 2.050	202	421221	Kit, Charge Relief
133	421209	Cover, Charge Pump	135		Ball Steel 7/16"
134	178343	Screw, Hex Flange 1/4-20 X .75	136		Spring, Relief .42 X .75
			137		Pin, Spring .125 X .875
			203	421222	Kit, Charge
			(131)		Gerotor Assembly (1.9cc/Rev)
			(132)		O-Ring 137 .103 X 2.050
			(133)		Cover, Charge Pump
			(134)		Screw, Hex Flange 1/4-20 X .75
			207	422128	Kit, Fan/Pulley
			(120)		Fan Recess 7.0 (10 Blade)
			(121)		Pulley 3.86 Inch
			(122)		Hex Lock Nut 1/2-20 (With Patch)
			(123)		Washer, Slotted

TRACTOR -- MODEL NUMBER 917.253710

HYDRO GEAR TRANSAXLE -- MODEL NUMBER G7-BCBB-1XDC-1FCA

KEY NO.	PART NO.	DESCRIPTION
210	421224	Kit, Input Shaft, Shaft, Input Brg, Ball 17 X 40 X 12 OpeN 6203 Ring, Ret Wire .561 Id
212	178329	Kit, Brake-Yoke, Bolt, Square Head Brake-Yoke
214	421225	Kit, G700 Ros
	141	Assembly Rtn, Neutral
	156	Retainer, Switch
	157	Rivet, 5/32
	158	Switch, Rcs
215	421226	Kit, G700 Rtn/Ros
	44	Arm, Control
	(46)	Screw, 5/16-18 X 1
	145	Assembly, Rtn
	146	Washer, .343 X 1.500 X .062
	157	Rivet, 5/32
	159	Clip, Actuator
216	421227	Kit, Breather Fitting, 9/16 Sae Cap, Barbed Vent
217	421228	Kit, Bypass
	34	Bypass Arm
	(35)	Retaining Ring
218	421229	Kit, Filter Guard
	105	Hfhcs 1/4-20 X .75
	106	Guard, Filter, Lh
219	422129	Kit, Damper
	115	Damper
	116	Bracket
	117	Stud, Threaded Ball
	118	Washer, 5/16 Lock
	119	Nut, Hex 5/16-18

() Indicates that part is listed elsewhere and is available as an individual part.

**TRACTOR - - MODEL NUMBER 917.253710
 KOHLER ENGINE-MODEL NUMBER SV735, TYPE NUMBER 0019**

CRANKCASE 2-32-1

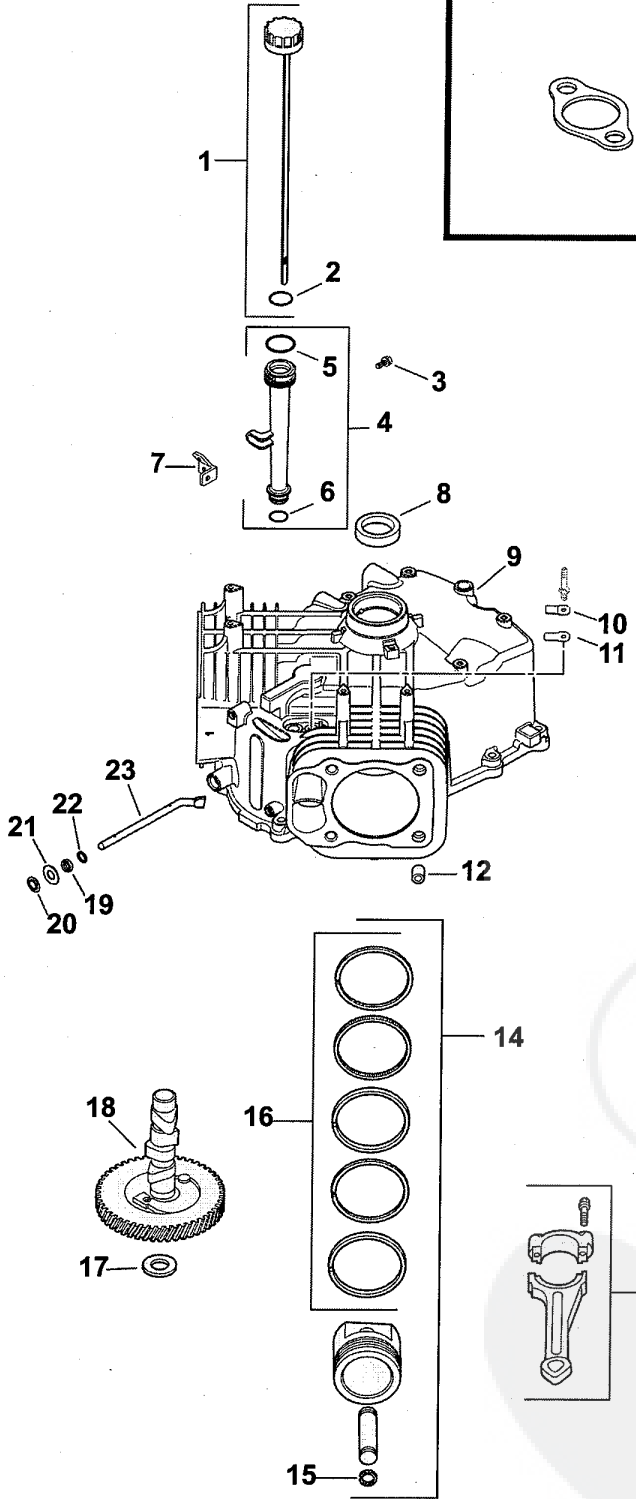

EXHAUST 11-32-2

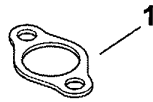

DECALS 12-32-21

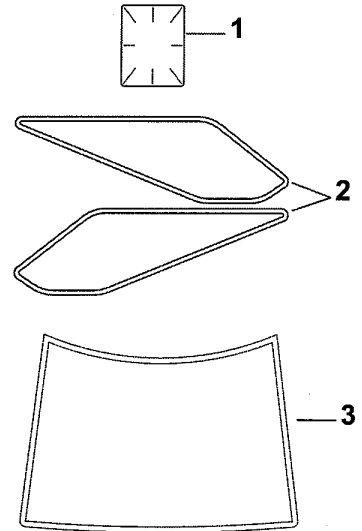

Artwork is representative.
 Actual labels may differ
 depending on model and
 specification number.

CRANKSHAFT 1-32-3

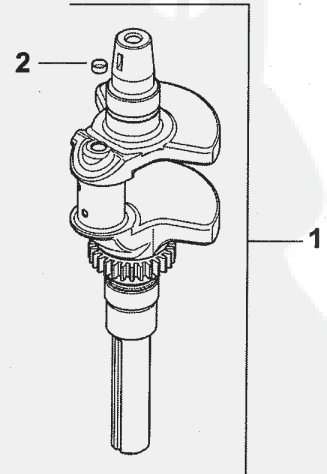

TRACTOR - - MODEL NUMBER 917.253710
KOHLER ENGINE-MODEL NUMBER SV735, TYPE NUMBER 0019

ENGINE CONTROLS 9-32-4

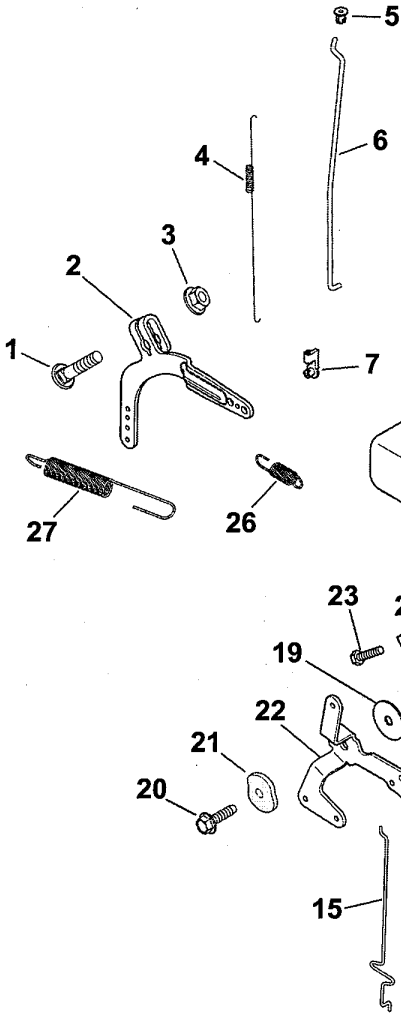

FUEL SYSTEM 8-32-9

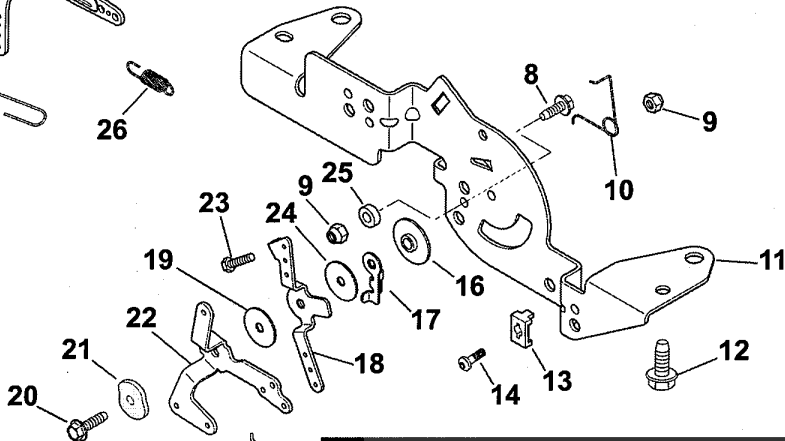
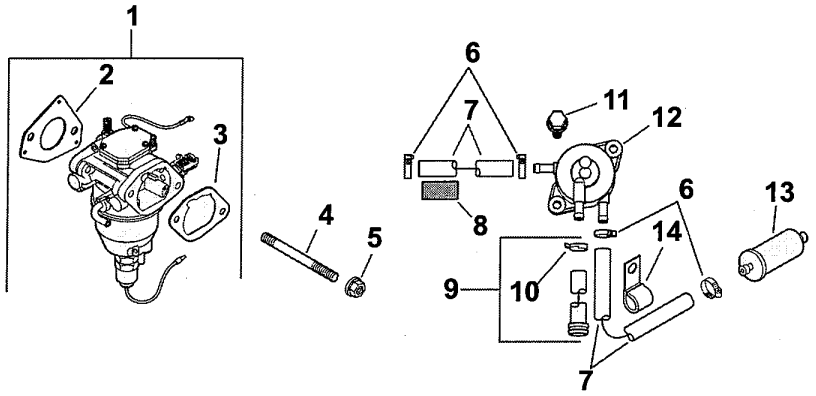

OIL PAN/LUBRICATION 3-32-4

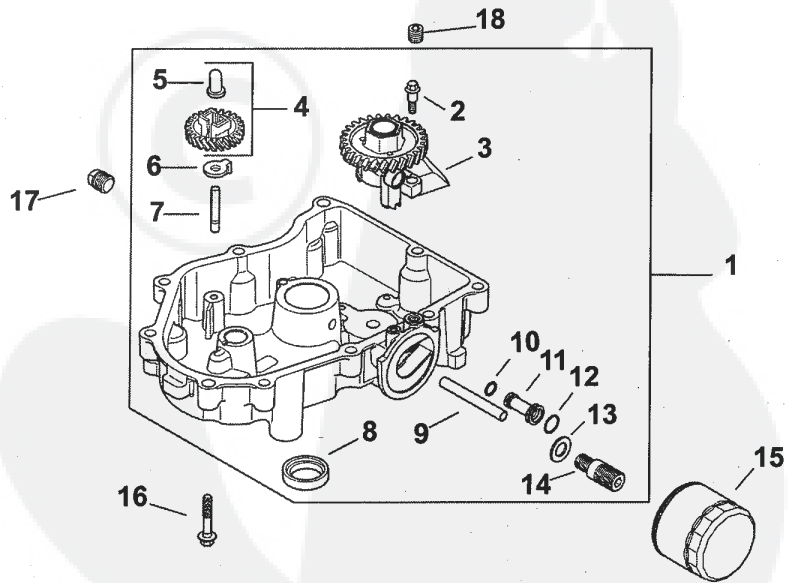

**TRACTOR - - MODEL NUMBER 917.253710
 KOHLER ENGINE-MODEL NUMBER SV735, TYPE NUMBER 0019**

HEAD/VALVE/BREATHER 4-32-1

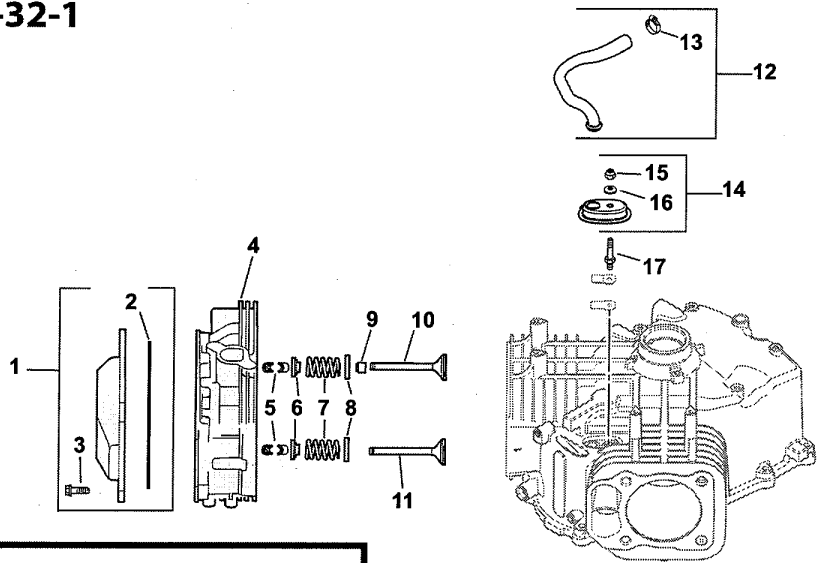

IGNITION/ELECTRICAL 5-32-37

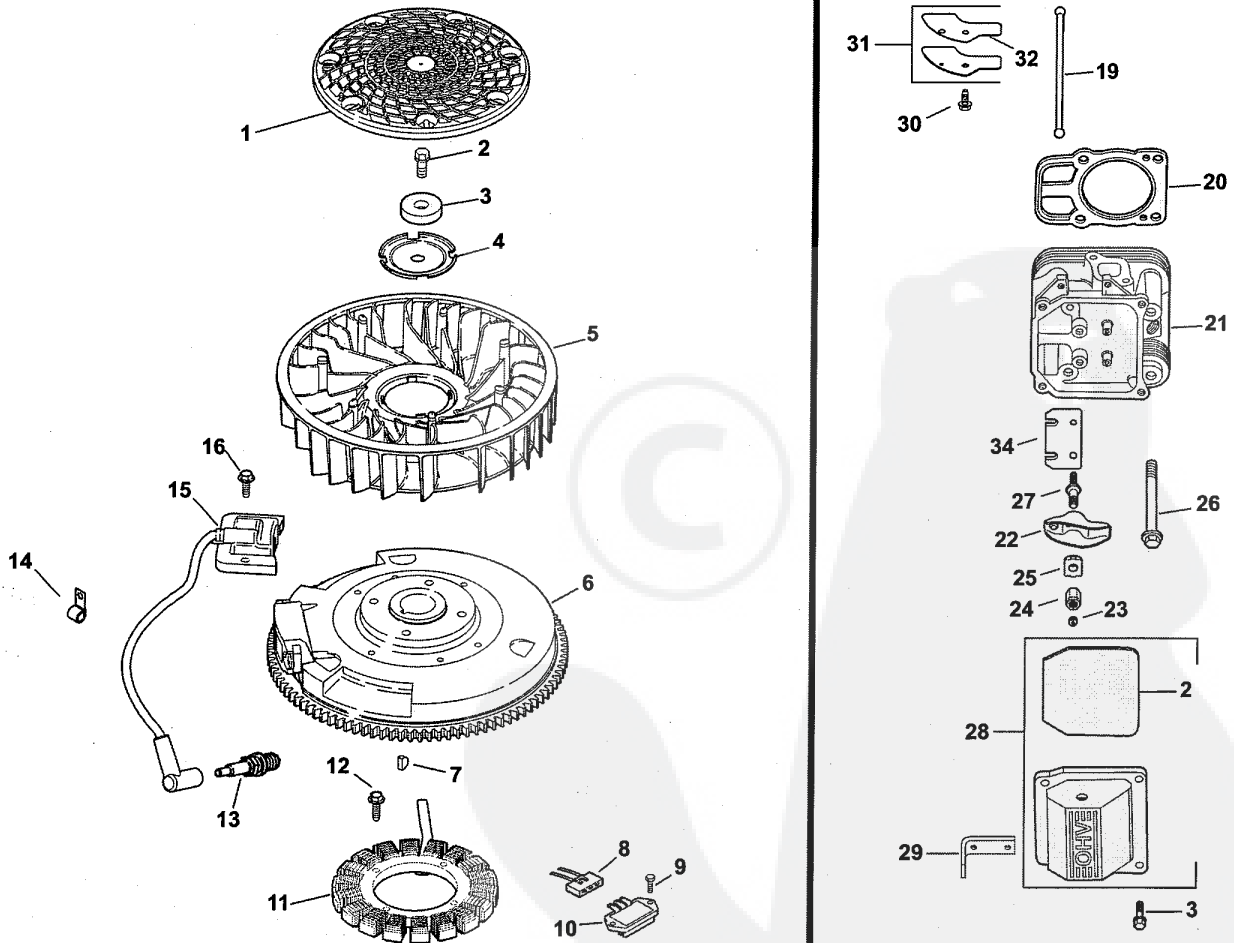

TRACTOR - - MODEL NUMBER 917.253710
KOHLER ENGINE-MODEL NUMBER SV735, TYPE NUMBER 0019

AIR INTAKE/FILTRATION 10-32-1

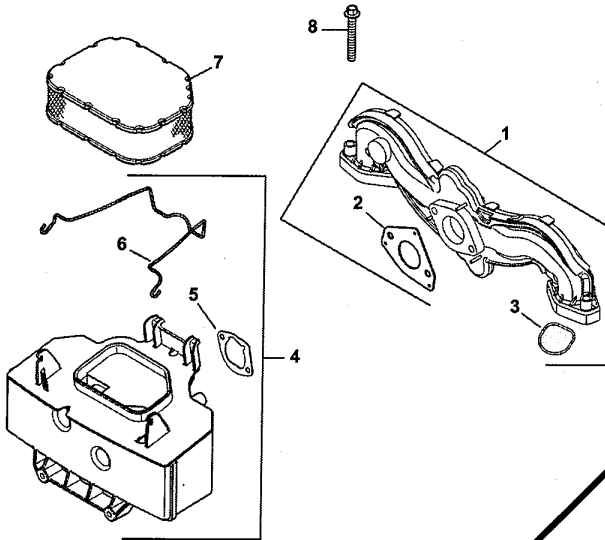

BLOWER HOUSING & BAFFLES 6-32-1

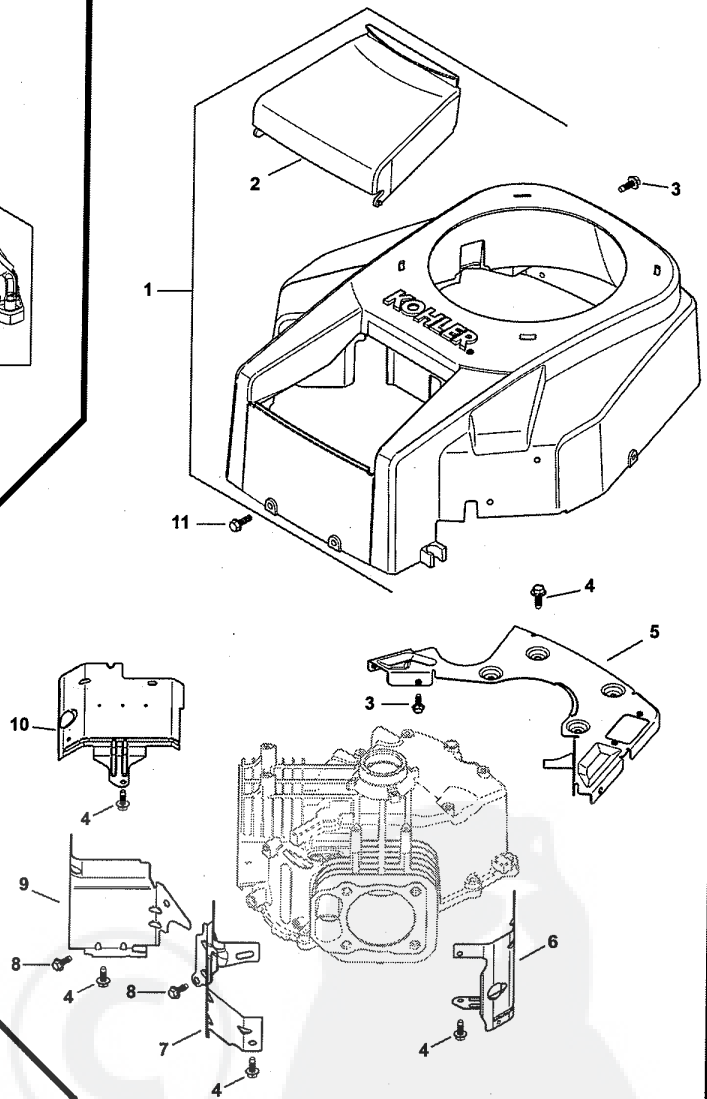

**STARTING SYSTEM
7-32-1**

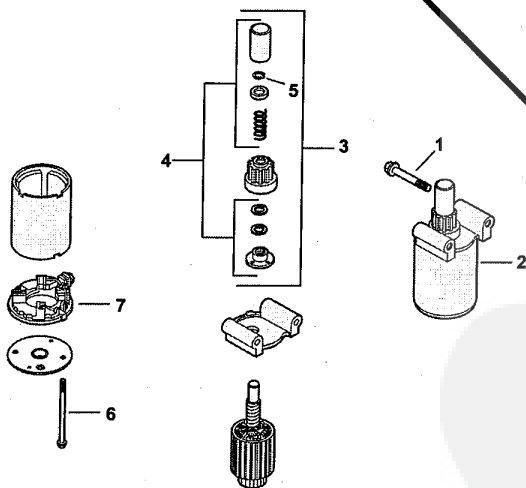

**TRACTOR - - MODEL NUMBER 917.253710
KOHLER ENGINE-MODEL NUMBER SV735, TYPE NUMBER 0019**

**KEY PART
NO. NO. DESCRIPTION**

CRANKSHAFT 1-32-3

1	32 014 02-s	Crankshaft (Incl. 2)
2	52 139 09-s	Plug, Cup

CRANKCASE 2-32-1

1	24 038 04-s	Dipstick, Assy (Incl. 2)
2	25 153 02-s	O-ring, Dipstick
3	M-545013-s	Screw, Flg Thd Frm M5 X 0.8 X 13
4	12 123 35-s	Tube, Oil Fill Assembly
5	12 153 02-s	O-ring, Upper Oil Fill Tube
6	12 153 01-s	O-ring, Lower Oil Fill Tube
7	24 126 19-s	Bracket, Oil Fill Tube
8	24 032 19-s	Seal, Oil (Helix Lip)
9		Crankcase (Use Short Block)
10	24 018 04-s	Retainer, Breather Reed
11	12 402 02-s	Reed, Breather
12	24 380 16-s	Pin, Locating
13	24 067 24-s	Connecting Rod (Std)
14	25 874 01-s	Kit, Piston W/ring Set (Std) (Incl. 15, 16)
--	24 874 27-s	Kit, Piston W/ring Set (.08)
--	24 874 28-s	Kit, Piston W/ring Set (.25)
15	24 018 01-s	Retainer, Piston Pin
16	24 108 14-s	Ring Set (Std)
--	24 108 15-s	Ring Set (.08)
--	24 108 16-s	Ring Set (.25)
17	12 422 07-s	Shim, Camshaft (White .028")
--	12 422 08-s	Shim, Camshaft (Blue .03")
--	12 422 09-s	Shim, Camshaft (Red .032")
--	12 422 10-s	Shim, Camshaft (Yellow .034")
--	12 422 11-s	Shim, Camshaft (Green .036")
--	12 422 12-s	Shim, Camshaft (Gray .038")
--	12 422 13-s	Shim, Camshaft (Black .04")
18	32 012 01-s	Kit, Camshaft (Incl. 25 357 14-s)
19	28 032 09-s	Seal, Governor Cross Shaft
20	24 018 09-s	Retainer, Ring
21	M-931010-s	Washer, Flat 9 Mm
22	24 468 15-s	Washer, Flat 11/32"
23	24 144 38-s	Shaft, Governor Cross

NOT ILLUSTRATED

--	25 357 14-s	Lubricant, Camshaft
----	-------------	---------------------

OIL PAN/LUBRICATION 3-32-4

1	32 199 07-s	Pan Assembly, Oil (Incl. 2-14)
2	32 086 01-s	Screw, Shd Thd Frm M6x.0x6.5
3	32 393 10-s	Pump Assembly, Oil
4	24 043 12-s	Kit, Governor Gear W/pin (Incl. 5)
5	12 380 01-s	Pin, Governor Regulating
6	24 448 02-s	Tab, Locking
7	12 144 02-s	Shaft, Governor Gear
8	24 032 06-s	Seal, Oil (W/o Grease)
9	32 123 01-s	Tube, Oil Feed - Filter To Pan
10	24 153 01-s	O-ring, Oil Pick-up
11	32 123 06-s	Tube, Oil Feed
12	32 153 05-s	O-ring
13	32 468 02-s	Washer, Flat
14	32 136 05-s	Nipple, Oil Filter
15	12 050 01-s	Filter, Oil
16	24 086 17-s	Screw, Flg M8x1.25x45
17	25 139 57-s	Plug, Sq Hd Pipe 3/8"

**KEY PART
NO. NO. DESCRIPTION**

HEAD/VALVE/BREATHER 4-32-1

1	24 755 141-s	Kit, Plain Rocker Cover (Incl. 2 [Qty 1], 3 [Qty 4])
2	24 153 30-s	O-ring, Valve Cover
3	M-651030-s	Screw, Flg M6x1.0x30
4	32 318 05-s	Kit, #1 Cylinder Head Assy (Incl. 26 [Qty 4] & 24 841 03-s)
5	12 755 03-s	Kit, Retainer
6	12 173 01-s	Cap, Valve Spring
7	24 089 02-s	Spring, Valve
8	235011-s	Retainer, Spring
9	66 032 05-s	Seal, Valve Stem
10	24 017 01-s	Valve, Intake (Std)
11	24 016 01-s	Valve, Exhaust (Std)
12	32 326 06-s	Kit, Breather Hose (Incl. 13[Qty 1])
13	25 237 14-s	Clamp, Hose
14	32 081 02-s	Kit, Breather Housing (Incl. 15, 16)
15	M-547050-s	Nut, Lock M5x0.8
16	32 468 01-s	Washer, Sealing
17	32 072 03-s	Stud, Breather Cover
18	32 019 02-s	Tappet
19	32 411 04-s	Rod, Push
20	24 841 03-s	"Kit, Cylinder Head Gasket (Incl. Head Mounting Hardware & 24 041 49-s, 24 153 27-s)"
21	32 318 06-s	Kit, #2 Cylinder Head Assy (Incl. 26 [Qty 4] & 24 841 03-s)
22	32 186 03-s	Arm, Rocker
23	25 100 33-s	Nut, M10x0.75
24	25 086 128-s	Screw, Set
25	25 599 01-s	Pivot, Rocker Arm
26	12 086 16-s	Screw, Flg M10x1.5x90
27	32 072 04-s	Stud, Rocker
28	32 096 06-s	Kit, Breather Valve Cover (Incl. 2[Qty 1])
29	24 445 01-s	Strap, Lifting
30	M-645016-s	Screw, Flg Thd Frm M6x1.0x16
31	32 096 04-s	Kit, Breather Cover (Incl. 32)
32	32 041 01-s	Gasket, Breather Cover
33	32 050 01-s	Filter, Breather
34	32 146 09-s	Plate, Guide

NOT ILLUSTRATED

--	24 041 49-s	Gasket, Exhaust
--	24 153 27-s	O-ring, Intake Port
--	32 755 03-s	"Kit, Cylinder Head Hardware (Services 1 Head. (Incl. 5-11, 19, 22, 25, 34))"

STARTING SYSTEM 7-32-1

1	M-839080-s	Screw, Flg M8x1.25x80
2	32 098 01-s	Starter Assembly
3	12 755 39-s	Kit, Drive
4	12 755 38-s	Kit, Drive Parts (Incl. 5)
5	32 141 01-s	Ring, Retaining
6	32 211 01-s	Bolt, Thru
7	12 243 04-s	Commutator, End Cap

NOTE: All component dimensions given in U.S. inches
1 inch = 25.4 mm

**TRACTOR - - MODEL NUMBER 917.253710
KOHLER ENGINE-MODEL NUMBER SV735, TYPE NUMBER 0019**

KEY NO.	PART NO.	DESCRIPTION
IGNITION/ELECTRICAL 5-32-37		
1	32 162 03-s	Screen, Grass
2	12 086 14-s	Screw, Flg M10x1.5x45
3	12 468 03-s	Washer, Flat 13/32"
4	20 146 05-s	Plate, Fan Mounting
5	32 157 01-s	Fan
6	32 025 15-s	Flywheel Assembly (Sv735/740)
7	X-42-15-s	Key, 3/16" X 5/8"
8	25 155 41-s	Connect0r
9	M-545016-s	Screw, Flg Thd Frm M5x0.8x16
10	41 403 10-s	Regulator/rectifier
11	237878-s	Kit, 15 Amp Stator (Incl. 25 452 01-s)
12	M-548025-s	Screw, Thd Frm M5x0.8x25
13	25 132 14-s	Spark Plug, Rfi
14	47 154 01-s	Clip, Cable
15	24 584 52-s	Module Spark Adv (Dsai) Assy
16	M-545020-s	Screw, Flg Thd Frm M5x.8x20

NOT ILLUSTRATED

--	25 454 03-s	Tie, Wire
--	32 176 17-s	Kit, Harness, Wiring
--	25 452 01-s	Terminal

BLOWER HOUSING & BAFFLES 6-32-1

1	32 027 03-s	Kit, Housing Blower (Incl. 2, 41 037 10-s)
2	32 096 08-s	Cover, Air Cleaner
3	M-545016-s	Screw, Flg Thd Frm M5x0.8x16
4	M-645016-s	Screw, Flg Thd Frm M6x1.0x16
5	32 146 05-s	Plate, Backing
6	32 063 12-s	Baffle, Cyl Barrel - #2 Side
7	32 063 02-s	Baffle, Valley #2 Side
8	M-545010-s	Screw, Flg Thd Frm M5x0.8x10
9	32 063 03-s	Baffle, Valley #1 Side
10	32 063 10-s	Baffle, Cyl Barrel - #1 Side
11	24 086 12-s	Screw, Tap M6x1.7x18

NOT ILLUSTRATED

--	41 037 10-s	Nameplate, Service
--	25 086 158-s	Screw, Thread Forming

FUEL SYSTEM 8-32-9

1	32 853 08-s	Kit, Carburetor W/gaskets (Incl. 2,3)
2	24 041 52-s	Gasket, Carburetor
3	24 041 14-s	Gasket, Air Cleaner Base
4	M-629105-s	Stud, M6x1.0x106
5	M-641060-s	Nut, Flg M6x1.0
6	25 237 14-s	Clamp, Hose
7	25 111 34-s	Line, Fuel (24"-cut To Length)
8	25 431 10-s	Sleeve, Anti Abrasion
9	32 326 02-s	Kit, Fuel Pump Hose W/clamp (Incl. 10)
10	25 237 01-s	Clamp, Hose
11	24 086 12-s	Screw, Tap M6x1.7x18
12	24 393 16-s	Pump, Fuel
13	24 050 13-s	Filter, Fuel
14	47 154 01-s	Clip, Cable

NOT ILLUSTRATED

--	24 757 44-s	Kit, Repair Float
--	24 757 46-s	Kit, Repair Overhaul
--	24 757 36-s	Kit, Repair Service Choke
--	24 757 38-s	Kit, Repair Service Gasket
--	24 757 45-s	Kit, Repair Solenoid Valve

KEY NO.	PART NO.	DESCRIPTION
ENGINE CONTROLS 9-32-4		
1	24 211 03-s	Bolt, Rd Hd Sq Neck M6x1.0x25
2	24 090 51-s	Lever, Governor
3	M-641060-s	Nut, Flg M6x1.0
4	24 089 01-s	Spring, Linkage
5	25 158 08-s	Bushing, Linkage Retaining
6	24 079 04-s	Linkage, Throttle
7	25 158 11-s	Bushing, Throttle Linkage
8	M-545016-s	Screw, Flg Thd Frm M5x0.8x16
9	M-547050-s	Nut, Lock M5x.8
10	24 089 03-s	Spring, Choke Return
11	24 126 172-s	Bracket, Control
12	M-645016-s	Screw, Flg Thd Frm M6x1.0x16
13	12 237 01-s	Clamp, Cable
14	24 086 43-s	Screw, Lbd Thd Frm M5x0.8x16
15	24 079 22-s	Linkage, Choke
16	24 112 27-s	Spacer, Control Assembly
17	24 090 47-s	Lever, Throttle Actuator
18	24 090 13-s	Lever, Throttle Control
19	24 468 01-s	Washer, Flat 5.5 Mm
20	M-545020-s	Screw, Flg Thd Frm M5x.8x20
21	41 468 03-s	Washer, Spring 1/4"
22	24 090 05-s	Lever, Choke
23	25 086 135-s	Screw, Hex Hd Cap (W/loctite)
24	24 468 20-s	Washer, Flat 5 Mm
25	24 112 24-s	Spacer
26	24 089 56-s	Spring, Governor
27	24 089 55-s	Spring, Governor

AIR INTAKE/FILTRATION 10-32-1

1	24 164 91-s	Manifold, Intake (Incl. 2,3)
2	24 041 52-s	Gasket, Carburetor
3	24 153 27-s	O-ring, Intake Port
4	32 094 04-s	Kit, Air Cleaner Base (Incl. 5,6)
5	24 041 14-s	Gasket, Air Cleaner Base
6	32 344 02-s	Latch, Air Cleaner Element
7	32 083 03-s	Element, Air Filter
8	M-651040-s	Screw, Flg M6x1.0x40

EXHAUST 11-32-2

1	24 041 49-s	Gasket, Exhaust
---	-------------	-----------------

DECALS 12-32-21

1	25 113 39-s	Decal, Clear Laminate
2	32 113 23-s	Decal, Wing Set Sears
3	32 113 27-s	Decal, 26hp

NOT ILLUSTRATED

SHORT BLOCK 42-32-2

--	32 522 02	SV710-740 Shortblock
--	32 755 01-s	Gasket Set

NOTE: All component dimensions given in U.S. inches
1 inch = 25.4 mm

SERVICE NOTES

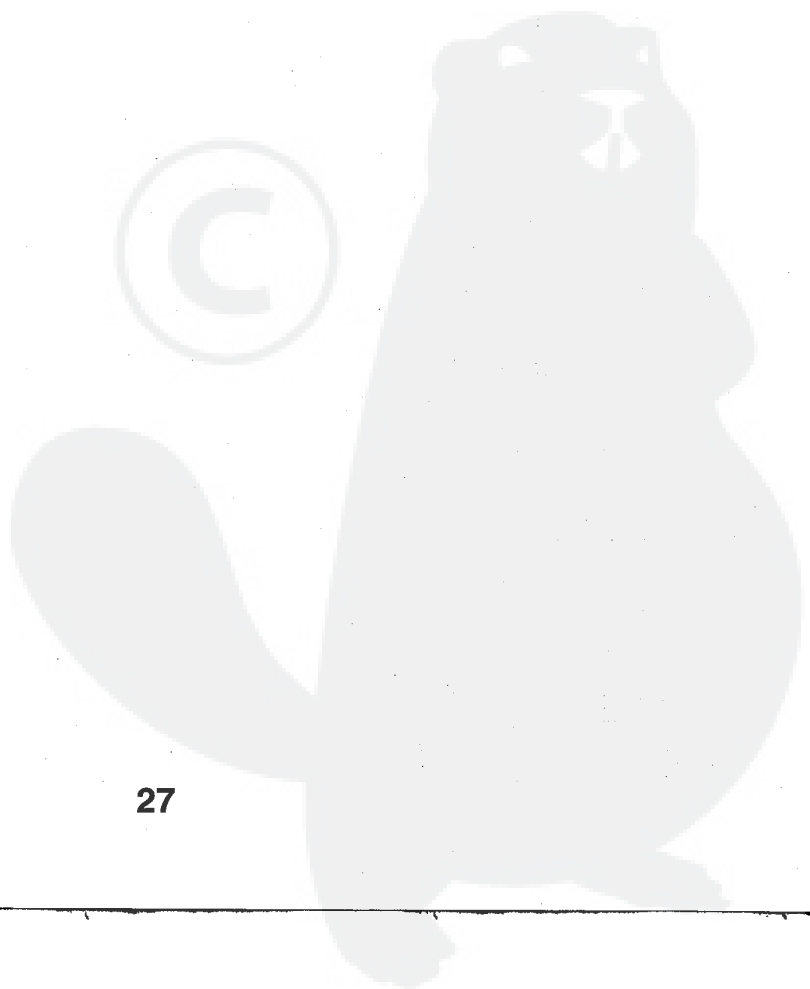
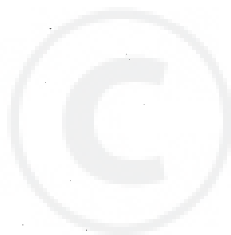

LIMITED WARRANTY ON CRAFTSMAN RIDING EQUIPMENT

For two (2) years from the date of purchase, if this Craftsman Riding Equipment is maintained, lubricated and tuned up according to the instructions in the owner's manual, Sears will repair or replace free of charge any parts that are found to be defective in material or workmanship according to the guidelines of coverage listed below. Sears will also provide free labor for these applicable warranted parts for the two full years. During the first 30 days of purchase, there will be no charges to service the product at your home for issues covered by this warranty. (See exclusions below). For your convenience, IN HOME warranty service will still be available after the first 30 days of purchase, but a trip charge will apply. This charge will be waived if the Craftsman product is dropped off at an authorized Sears location. For the nearest authorized Sears location, please call 1-800-4-MY-HOME®. This warranty applies only while this product is within the United States.

This Warranty does not cover:

- Expendable items which become worn during normal use, including but not limited to blades, spark plugs, air cleaners, belts, and oil filters.
- Standard Maintenance Servicing, oil changes, or tune-ups
- Tire replacement or repair caused by punctures from outside objects, such as nails, thorns, stumps, or glass.
- Repairs necessary because of operator abuse, including but not limited to, damage caused by towing objects beyond the capability of the riding equipment, impacting objects that bend the frame or crankshaft, or over-speeding the engine.
- Repairs necessary because of operator negligence, including but not limited to, electrical and mechanical damage caused by improper storage, failure to use the proper grade and amount of engine oil, failure to keep the deck clear of flammable debris, or failure to maintain the equipment according to the instructions contained in the owner's manual.
- Engine (fuel system) cleaning or repairs caused by fuel determined to be contaminated or oxidized (stale). In general, fuel should be used within 30 days of its purchase date.
- Normal deterioration and wear of the exterior finishes, or product label replacement.
- Riding equipment used for commercial or rental purposes.

LIMITED WARRANTY ON BATTERY

For ninety (90) days from date of purchase, if any battery included with this riding equipment proves defective in material or workmanship and our testing determines the battery will not hold a charge, Sears will replace the battery at no charge. During the first 30 days of purchase, there will be no charges to replace the battery at your HOME. After the first 30 days, for your convenience, IN-HOME warranty service will still be available but a trip charge will apply. This charge will be waived if the Craftsman product is dropped off at an authorized Sears location. For the nearest authorized Sears location, please call 1-800-4-MY-HOME®.

This battery warranty applies only while this product is within the United States.

This warranty gives you specific legal rights, and you may also have other rights, which vary, from state to state.

Sears, Roebuck and Co., Hoffman Estates, IL 60179



CRAFTSMAN®