

REPAIR PARTS MANUAL
MODEL NO. 257430
Lawn Tractor

CRAFTSMAN®

413059 02.15.07 TH
PRINTED IN U.S.A.

HOW TO USE THIS MANUAL

This manual is designed to provide the customer with a means to identify the parts on his/her tractor when ordering repair parts. The illustrations may or may not represent the actual assemblies; therefore, it is not recommended to use this manual as a guide to assemble or disassemble the tractor. Some hardware and parts are drawn larger in order to more readily identify them.

Each tractor has its own model number.

The model number for your tractor can be found on the fender under the seat.

When ordering parts, always give the following information:

- Product - "Tractor"
- Model Number - "257430"
- Part Number
- Part Description

TABLE OF CONTENTS

SCHEMATIC	3
ELECTRICAL	4-5
CHASSIS	6-7
DRIVE	8-9
STEERING	10-11
ENGINE	12-13
MOWER LIFT	14-15
SEAT	16
DECAL	17
MOWER DECK	18-19
TRANSAXLE	20-21
ENGINE BREAKDOWN	22-27
WARRANTY	BACK COVER

TRACTOR- -MODEL NO. 917. 257430

SCHEMATIC

02836_193374 / 390

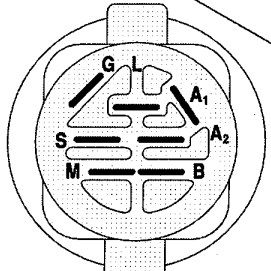
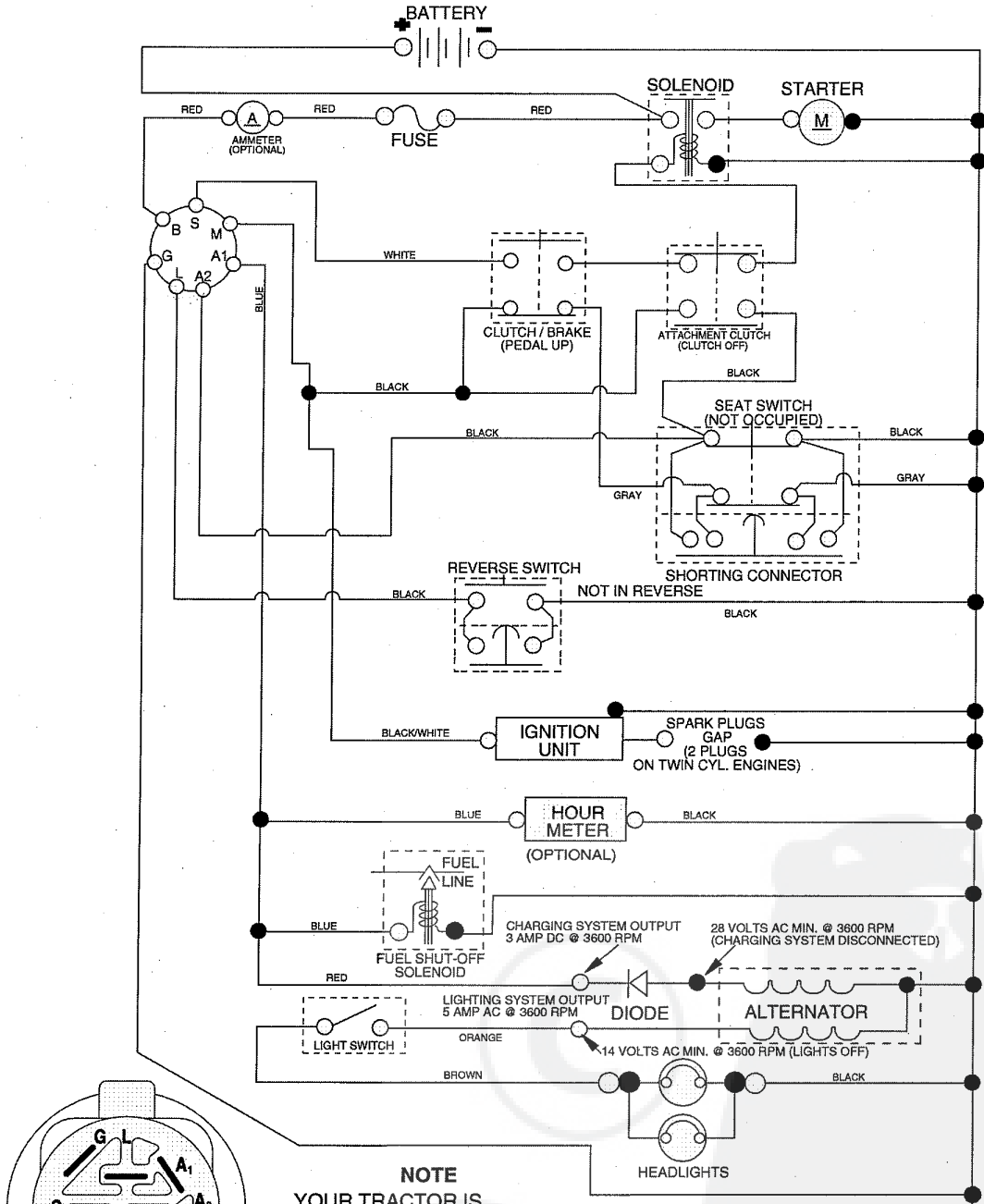

IGNITION SWITCH

POSITION	CIRCUIT	"MAKE"
OFF	M+G+A1	
RUN/OVERRIDE	B+A1	
RUN	B+A1	L+A2
START	B + S + A1	

NOTE
 YOUR TRACTOR IS EQUIPPED WITH A SPECIAL ALTERNATOR SYSTEM. THE LIGHTS ARE NOT CONNECTED TO THE BATTERY, BUT HAVE THEIR OWN ELECTRICAL SOURCE. BECAUSE OF THIS, THE BRIGHTNESS OF THE LIGHTS WILL CHANGE WITH ENGINE SPEED. AT IDLE THE LIGHTS WILL DIM. AS THE ENGINE IS SPEEDED UP, THE LIGHTS WILL BECOME THEIR BRIGHTEST.



WIRING INSULATED CLIPS
NOTE: IF WIRING INSULATED CLIPS WERE REMOVED FOR SERVICING OF UNIT, THEY SHOULD BE REPLACED TO PROPERLY SECURE YOUR WIRING.

02836

REPAIR PARTS

TRACTOR- -MODEL NO. 917. 257430

ELECTRICAL

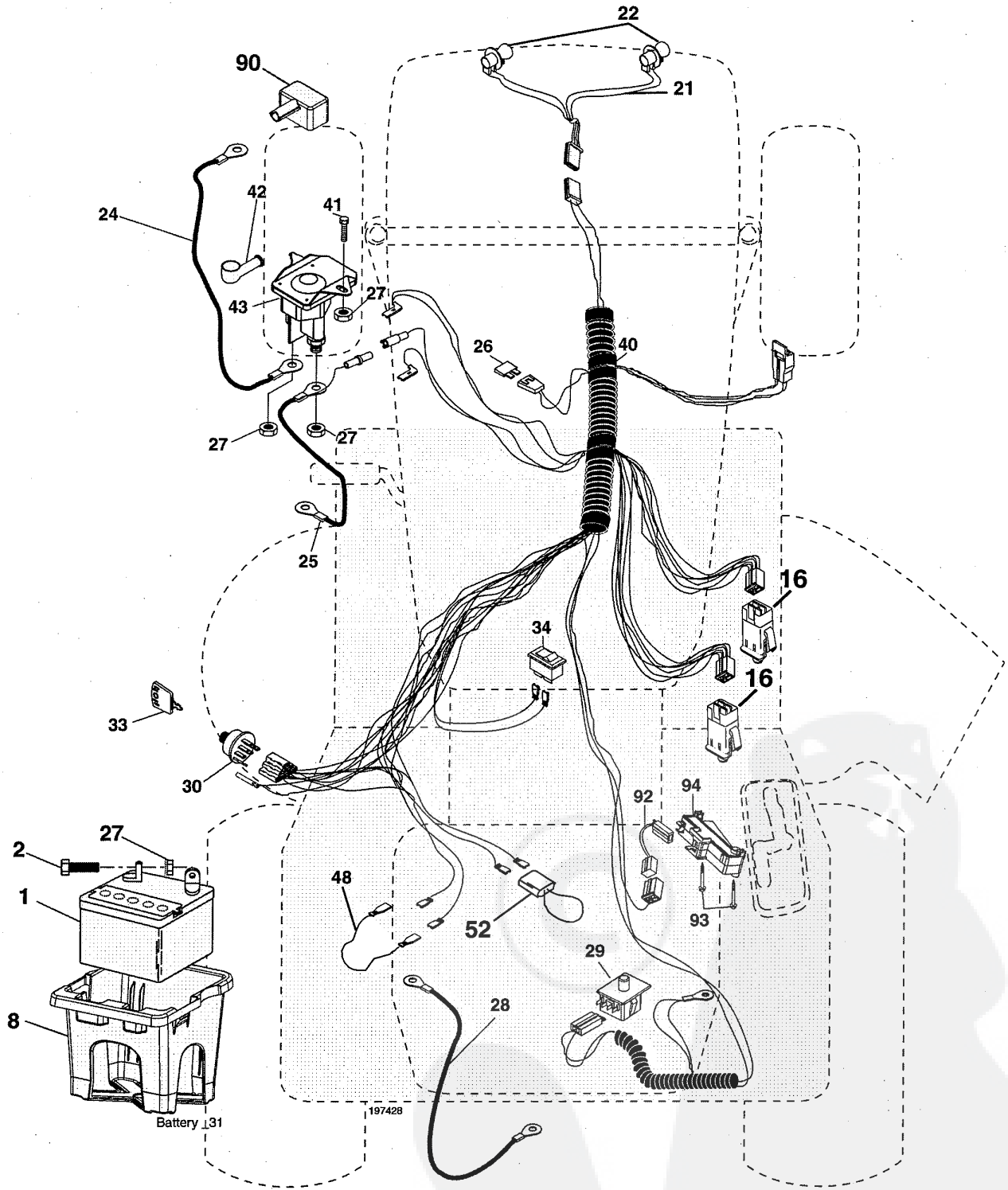

REPAIR PARTS

TRACTOR- -MODEL NO. 917. 257430

ELECTRICAL

KEY NO.	PART NO.	DESCRIPTION
1	163465	Battery
2	74760412	Bolt Hex Hd 1/4-20 unc x 3/4
8	176689	Box Battery Fender
16	176138	Switch, Interlock
21	175688	Harness Asm Light W/4152j
22	4152J	Bulb Light #1156
24	4799J	Cable Battery 6 Ga. 11" red
25	146147	Cable Battery 6 Ga. w/16 wire red
26	175158	Fuse 20 AMP
27	73510400	Nut, Keps Hex 1/4-20 unc
28	4207J	Cable Ground 6 Ga. 12" black
29	192749	Switch Seat
30	193350	Switch Ign
33	140403	Key Ign Molded Craftsman
34	110712X	Switch Light
40	197428	Harness Ign
41	71110408	Bolt Blk. Fin Hex 1/4-20 unc x 1/2
42	131563	Cover Terminal Red
43	192507	Solenoid
48	140844	Adapter Ammeter
52	141940	Protection Wire Loop
90	180449	Cover Battery Terminal
92	196615	Harness Pigtail Reverse Switch
93	192540	Screw Plastic 10-14 x 2.0
94	191834	Module Reverse ROS

NOTE: All component dimensions give in U.S. inches
1 inch = 25.4 mm

REPAIR PARTS

TRACTOR- -MODEL NO. 917. 257430

CHASSIS AND ENCLOSURES

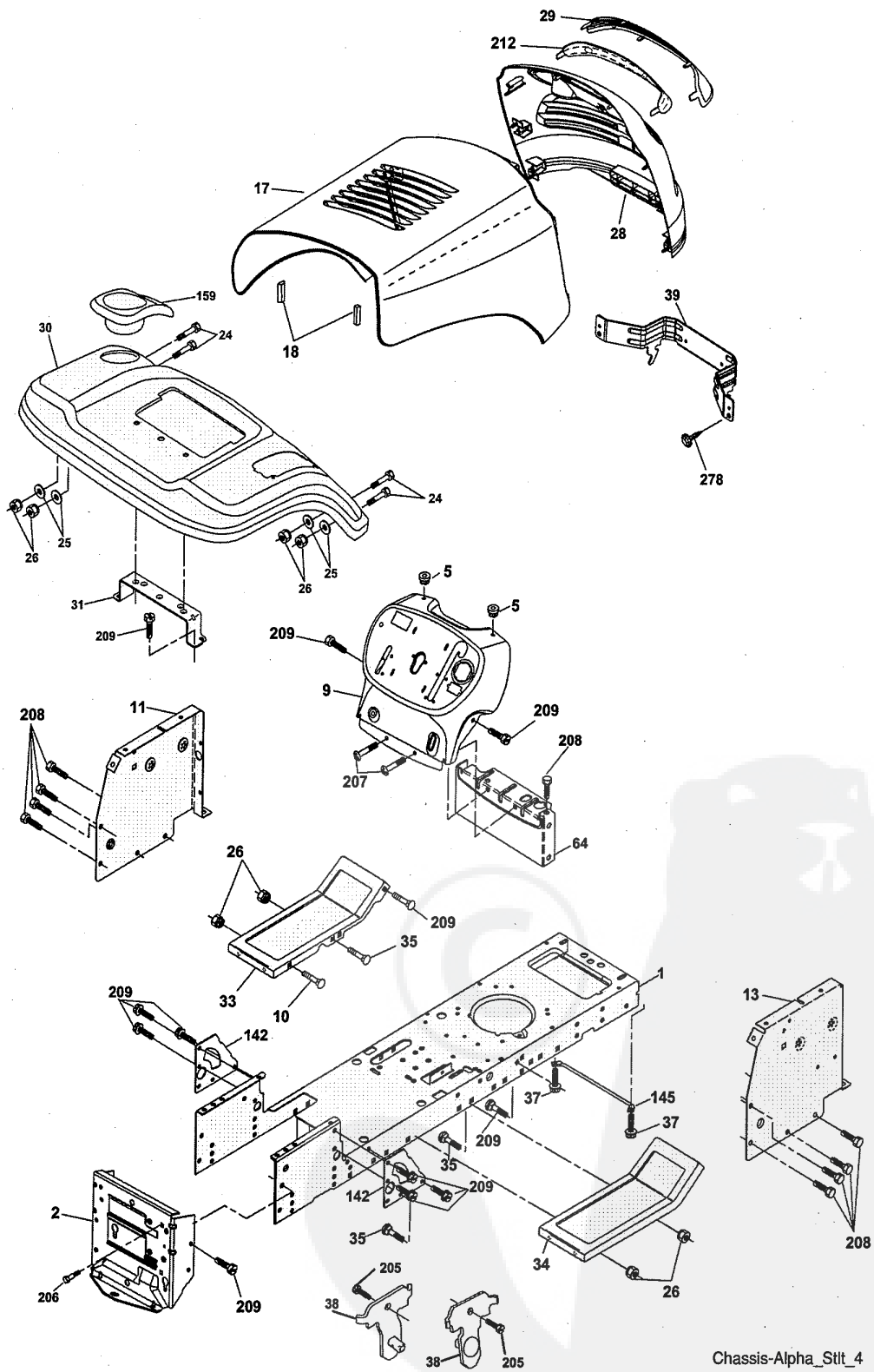

Chassis-Alpha_Stit_4

REPAIR PARTS

TRACTOR- -MODEL NO. 917. 257430

CHASSIS AND ENCLOSURES

KEY NO.	PART NO.	DESCRIPTION
1	174619	Chassis Stamping
2	176554	Drawbar
5	155272	Bumper Hood/Dash
9	193510X013	Dash
10	STD533710	Bolt, Carriage 3/8-16 x 1
11	174996	Panel, Dash, L.H.
13	172105X010	Panel, Dash, R.H.
17	187559X613	Hood Assembly Laser
18	184921	Bumper Hood Large 1.75
24	STD523710	Bolt Fin Hex 3/8-16 unc x 1 Gr. 5
25	19131312	Washer 13/32 x 13/16 x 12 Ga.
26	STD541437	Nut
28	187598	Grille Lens Asm Laser (Includes Key Nos. 29 and 212)
29	187567X599	Lens
30	192528X613	Fender
31	136619	Bracket, Fender Support
33	179716X613	Footrest LH
34	179717X613	Footrest RH
35	STD533707	Bolt Rdhd Sht Sqnk 3/8-16 x 3/4
37	17490508	Screw Thdrol 5/16-18 x 1/2 Tyt
38	175710	Bracket Asm. Pivot Mower Rear
39	187568	Bracket Pivot
64	154798	Dash Lower STLT
142	175702	Plate Reinforcement STLT
145	409167	Rod Pivot Chassis/Hood
159	169473X428	Cupholder
205	17490608	Screw Thdrol 3/8-16 x 1/2
206	170165	Bolt Shoulder 5/16 -18 TT
207	17670508	Screw Thdrol 5/16-18 x 1/2 TYTT
208	17670608	Screw Thdrol 3/8-16 x 1/2
209	17000612	Screw Hex Wsh Thdr 3/8-16 x 3/4
212	187569	Insert Lens Reflective
278	191611	Screw 10 x 3/4 Single Head-Hex
--	5479J	Plug, Button

NOTE: All component dimensions given in U.S. inches
1 inch = 25.4 mm

REPAIR PARTS

TRACTOR--MODEL NO. 917. 257430

DRIVE

KEY NO.	PART NO.	DESCRIPTION	KEY NO.	PART NO.	DESCRIPTION
1	-----	Transaxle, 322-0510 (Order Parts From Transaxle Manufacturer)	70	180218	Guide Belt Mower Drive RH
8	192706	Rod Shift Fender Adjust STLT	71	169183	Strap Torque LH
10	76020416	Pin Cotter 1/8 x 1 Cad	73	169182	Strap Torque RH
14	10040400	Washer Lock Hvy Helical 1/4	74	137057	Spacer Axle
15	74490544	Bolt 5/16-18 Gr. 5	75	121749X	Washer 25/32 x 1 1/4 x 16 Ga.
16	73800500	Nut Lock Hx W/Ins 5/16-18 unc Pl	76	12000001	E-ring #5133-75
19	73800600	Nut Lock 3/8-16 unc	77	123583X	Key Square 2 0 x 1845/ 1865
21	140845	Knob	78	121748X	Washer 25/32 x 1-5/8 x 16 Ga.
22	169498	Rod Brake Blk Zinc 26 840	81	165596	Shaft Asm Cross Tapered 18"
24	73350600	Nut Hex Jam 3/8-16 unc	82	16 57-11	Spring Torsion T/a
25	106888X	Spring Rod Brake 2 00 Zinc	83	19171216	Washer 17/32 x 3/4 x 16 Ga.
26	19131316	Washer 13/32 x 13/16 x 16 Ga	84	169843	Transaxle Link
27	76020412	Pin Cotter 1/8 x 3/4 Cad	89	192056x428	Console Shift STLT
28	175765	Rod Brake Parking LT/YT	95	170201	Control Asm Bypass
29	71673	Cap Brake Parking Black	96	4497H	Retainer Spring 1"
30	174973	Bracket Mtg Transaxle	103	73940800	Nut Hex Jam Toplock 1/2-20 UNF
32	74760512	Bolt Hex Hd 5/16-18 unc x 3/4	112	19091210	Washer 9/32 x 3/4 x 10 Ga.
34	175578	Shaft Asm Pedal Foot	116	72140608	Bolt Rdhd Sq Neck 3/8-16 x 1
35	120183X	Bearing Nylon Blk 629 Id	120	73900600	Nut Lock Flg. 3/8-16
36	19211616	Washer 21/32 x 1 x 16 Ga	150	175456	Spacer Retainer
37	1572H	Pin Roll 3/16 x 1"	151	19133210	Washer 13/32 x 2 x 10 Ga.
38	179114	Pulley Composite	156	166002	Washer Srrtd 5/16 ID x 1.125
39	72110622	Bolt Rdhd 3/8-16 x 2-3/4 Gr. 5	158	165589	Bracket Shift Mount
41	175556	Keeper Belt Idler Flat	159	183900	Hub Shift
47	127783	Pulley Idler V Groove Plastic	161	72140406	Bolt Rdhd Sqnk 1/4-20 x 3/4 Gr. 5
48	154407	Bellcrank Clutch Grnd Drv Stl	162	73680400	Nut Crownlock 1/4-20 unc
49	123205X	Retainer Belt Style Spring	163	74780416	Bolt Hex Fin 1/4-20 unc x 1 Gr. 5
50	72110612	Bolt Carr. sh 3/8-16 x 1-1/2 Gr. 5	165	165623	Bracket Pivot Lever
51	73680600	Nut Crownlock 3/8-16 unc	166	17490510	Screw 5/16-18 x 5/8
52	73680500	Nut Crownlock 5/16-18 unc	168	165492	Bolt Shoulder 5/16-18 x .561
53	199652	Link Clutch	169	165580	Plate Fastening STLT/CRD
55	105709X	Spring Return Clutch 6 75	197	169613	Nyliner Snap-In 5/8" ID
56	17060620	Screw 3/8-16 x 1-1/4	198	169593	Washer Nyl 7/8 Id x .105" Hyd
57	140294	V-Belt	199	169612	Bolt Shoulcer 5/16-18 UNC
59	169691	Keeper Belt Span Ctr	200	72140508	Bolt Rdhd Sqnk 5/16 - 18 unc x 1
61	17120614	Screw 3/8-16 x .875	202	72110614	Bolt 3/8-16 x 1-3/4 Gr. 5
62	8883R	Cover Pedal	205	19171616	Washer 17/32 x 1 x 16 Ga.
63	180219	Engine Pulley	212	145212	Nut Hex Flg Lock
64	173937	Bolt Hex	263	17000612	Screw 3/8-16 x 3/4
65	10040700	Washer Lock Hvy Hlcl Spr 7/16	268	182402	Guard Muffler
66	154778	Keeper Belt Engine Foolproof	275	19131614	Washer 13/32 x 1 x 14
69	142432	Screw Hex Wsh Hi-Lo 1/4-1/2 unc			

NOTE: All component dimensions given in U.S. inches
1 inch = 25.4 mm

REPAIR PARTS

TRACTOR- -MODEL NO. 917. 257430

STEERING ASSEMBLY

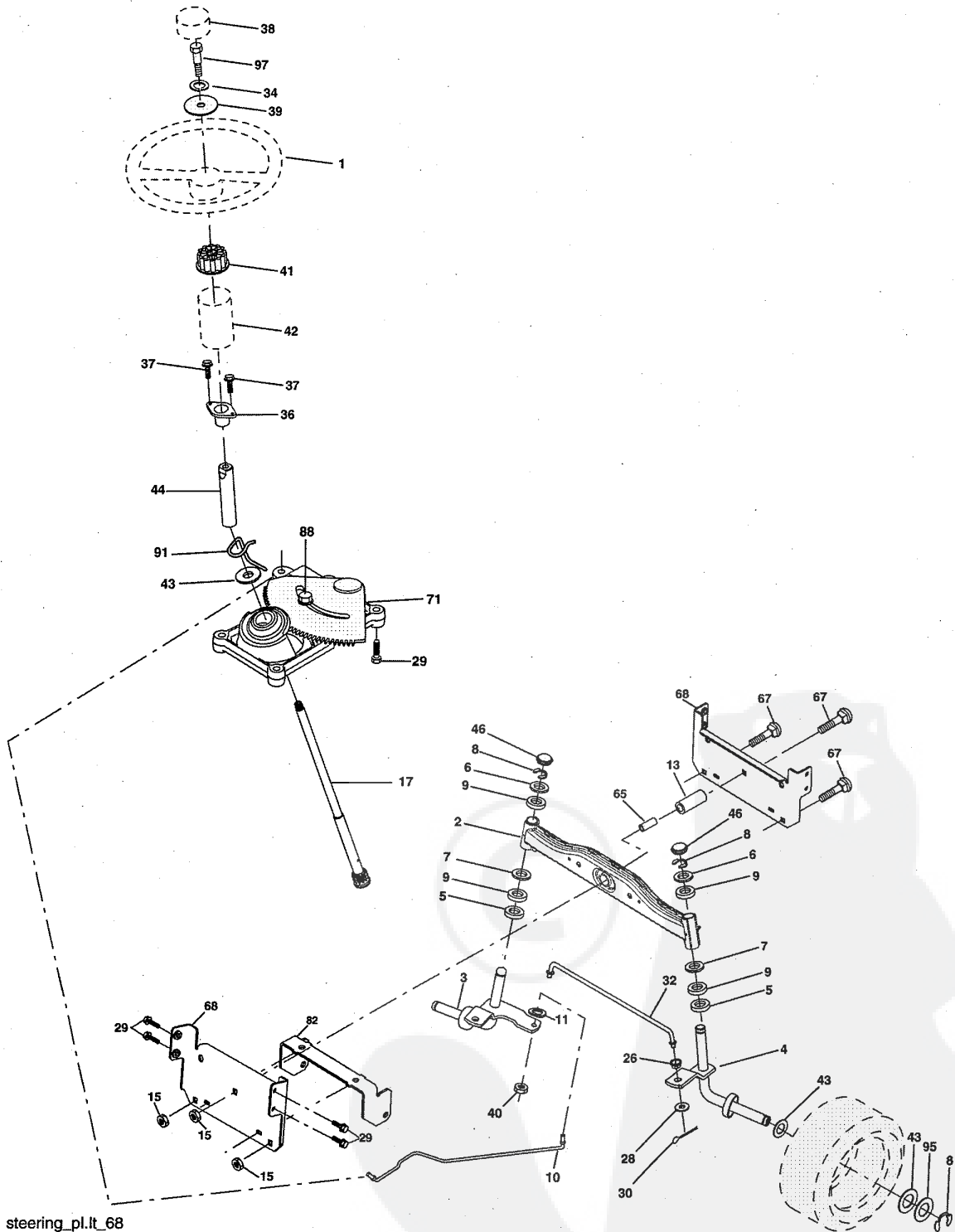

REPAIR PARTS

TRACTOR- -MODEL NO. 917. 257430

STEERING ASSEMBLY

KEY NO.	PART NO.	DESCRIPTION
1	186780	Steering Wheel
2	195673	Axle Assembly
3	169840	Spindle Assembly, L.H.
4	169839	Spindle Assembly, R.H.
5	6266H	Bearing, Race, Thrust, Hardened
6	121748X	Washer 25/32 x 1-5/8 x 16 Ga.
7	19272016	Washer 27/32 x 1-1/4 x 16 Ga.
8	12000029	Ring, Klip
9	3366R	Bearing Col. Strg.
10	175121	Draglink
11	STD551137	Washer, Lock
13	136518	Spacer Brg Axle Front
15	145212	Nut, Hexflange Lock
17	190753	Shaft, Steering
26	126847X	Bushing, Link, Drag
28	19131416	Washer 13/32 x 7/8 x 16 Ga.
29	17000612	Screw 3/8-16 x 3/4
30	STD561210	Pin
32	192757	Rod, Tie
34	10040500	Washer Lock Hvy Hlcl Spr. 5/16
36	155099	Bushing, Steering
37	152927	Screw
38	186781	Insert, Steering Wheel
39	19113812	Washer 11/32 ID x 2-3/8 OD x 12 Ga.
40	73540600	Nut Crownlock 3/8-24
41	186737	Adaptor, Steering Wheel
42	145054x428	Boot, Steering Shaft
43	121749X	Washer 25/32 x 1-1/4 x 16 Ga.
44	190752	Extension Shaft Steering
46	121232X	Cap, Spindle
65	160367	Spacer Brace Axle
67	72110618	Bolt Rdhd Sqnk 3/8-16 x 2-1/4
68	169827	Axle, Brace
71	175146	Steering Asm
82	199978	Bracket Susp Chassis Front
88	175118	Bolt Shoulder 7/16-20
91	175553	Clip Steering
95	188967	Washer Hardened .793 x 1.637 x .060
97	74780564	Bolt 5/16-18 unc x 4 Gr. 5

NOTE: All component dimensions give in U.S. inches
1 inch = 25.4 mm

REPAIR PARTS

TRACTOR- -MODEL NO. 917. 257430

ENGINE

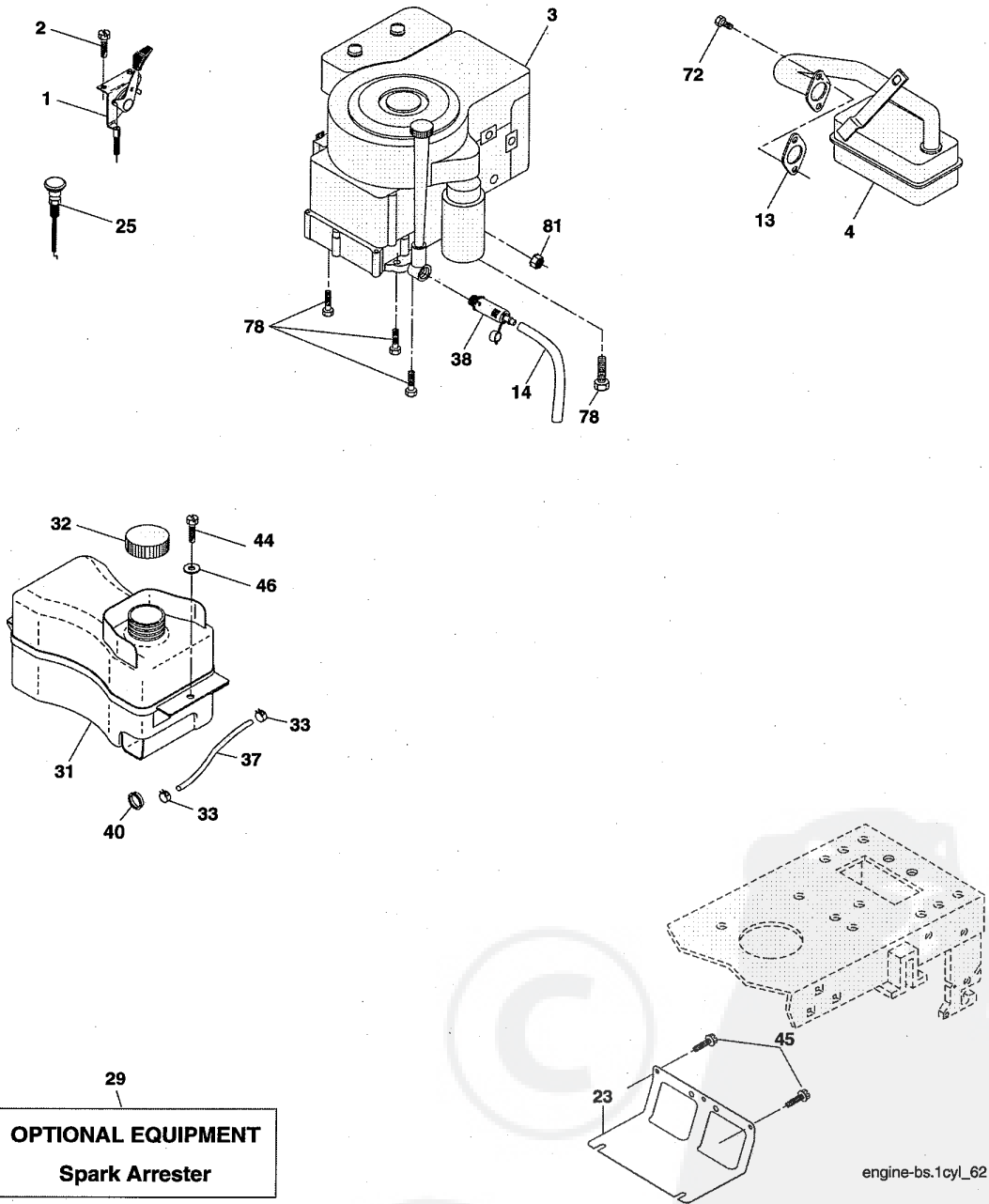

engine-bs.1cyl_62

REPAIR PARTS

TRACTOR- -MODEL NO. 917. 257430

ENGINE

KEY NO.	PART NO.	DESCRIPTION	KEY NO.	PART NO.	DESCRIPTION
1	170545	Control, Throttle/Choke	37	137040	Line, Fuel
2	17720408	Screw, Hex Head, Thread Cutting 1/4-20 x 1/2	38	181654	Plug, Drain Oil Easy
3	-----	Engine, Briggs Model No. 31C707-0240-B1 (See Engine Breakdown)	40	124028X	Bushing Snap
4	137352	Muffler	44	17670412	Screw, Hex Washer Head, Thd., Roll. 1/4-20 x 3/4
13	165291	Gasket	45	17000612	Screw Hex Wsh Thdr 3/8-16 x 3/4
14	148456	Tube Drain Oil Easy	46	19091416	Washer 9/32 x 7/8 x 16 Ga.
23	169837	Shield Brn/Dbr Guard	72	192334	Screw Socket Head Cap 5/16-18 x 3/4
25	187770X428	Control Choke	78	17060620	Screw 3/8-16 x 1-1/4
29	137180	Arrestor, Spark	81	73510400	Nut Keps Hex 1/4-20 unc
31	407516	Tank, Fuel			
32	197725	Cap Assembly, Fuel			
33	123487X	Clamp, Hose			

NOTE: All component dimensions give in U.S. inches
1 inch = 25.4 mm

Engine Power Rating Information

The gross power rating for individual gas engine models is labeled in accordance with SAE (Society of Automotive Engineers) code J11940 (Small Engine Power & Torque Rating Procedure), and rating performance has been obtained and corrected in accordance with SAE J1995 (Revision 2002-5). Actual gross engine power will be lower and is affected by, among other things, ambient operating conditions and engine-to-engine variability. Given both the wide array of products on which engines are placed and the variety of environmental issues applicable to operating the equipment, the gas engine will not develop the rated gross power when used in a given piece of power equipment (actual "on-site" or net horsepower). This difference is due to a variety of factors including, but not limited to, accessories (air cleaner, exhaust, charging, cooling, carburetor, fuel pump, etc.), application limitations, ambient operating conditions (temperature, humidity, altitude), and engine-to-engine variability. Due to manufacturing and capacity limitations, Briggs & Stratton may substitute an engine of higher rated power for this Series engine.

REPAIR PARTS

TRACTOR- -MODEL NO. 917. 257430

MOWER LIFT

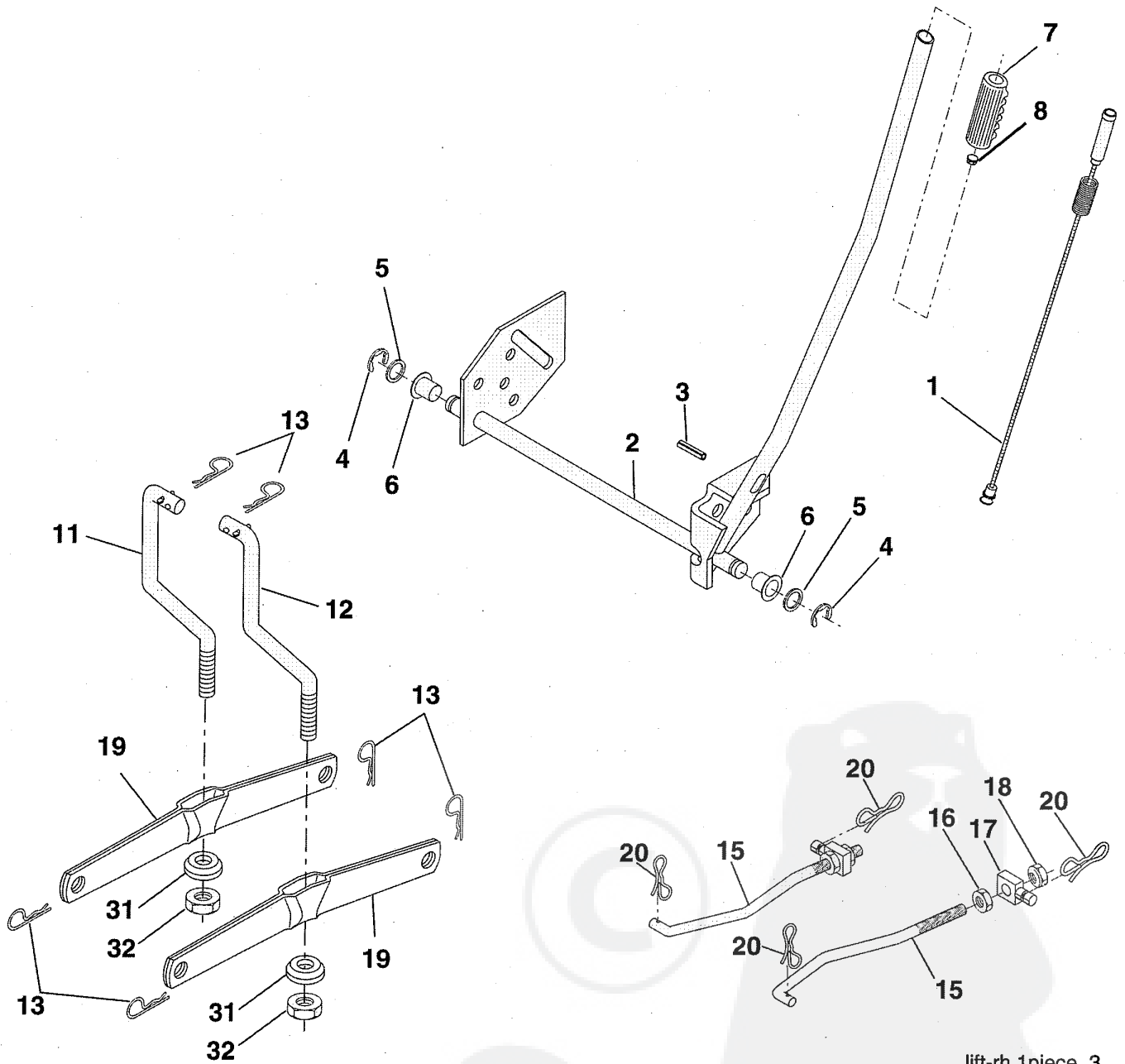

lift-rh.1piece_3

REPAIR PARTS

TRACTOR- -MODEL NO. 917. 257430

MOWER LIFT

KEY NO.	PART NO.	DESCRIPTION
1	159460	Lift Lever Inner Wire Assembly
2	159471	Shaft Assembly, Lift
3	105767X	Pin, Groove
4	12000002	E-Ring
5	19211621	Washer 21/32 x 1 x 21 Ga.
6	120183X	Bearing, Nylon
7	125631X	Grip, Handle, Fluted
8	122365X	Button, Plunger, Red
11	139865	Link, Lift, L.H.
12	139866	Link, Lift, R.H.
13	STD624008	Retainer Spring
15	173288	Link, Front
16	73350800	Nut, Hex, Jam 1/2-13 unc
17	175689	Trunnion
18	73800800	Locknut, Hex, with Washer Insert 1/2-13 unc
19	139868	Arm, Suspension, Rear
20	194209	Pin Cotter 7/16 Bow Tie Lock
31	169865	Bearing, Pvt, Lift
32	73540600	Nut, Crownlock 3/8-24

NOTE: All component dimensions give in U.S. inches
1 inch = 25.4 mm

REPAIR PARTS

TRACTOR- -MODEL NO. 917. 257430

SEAT

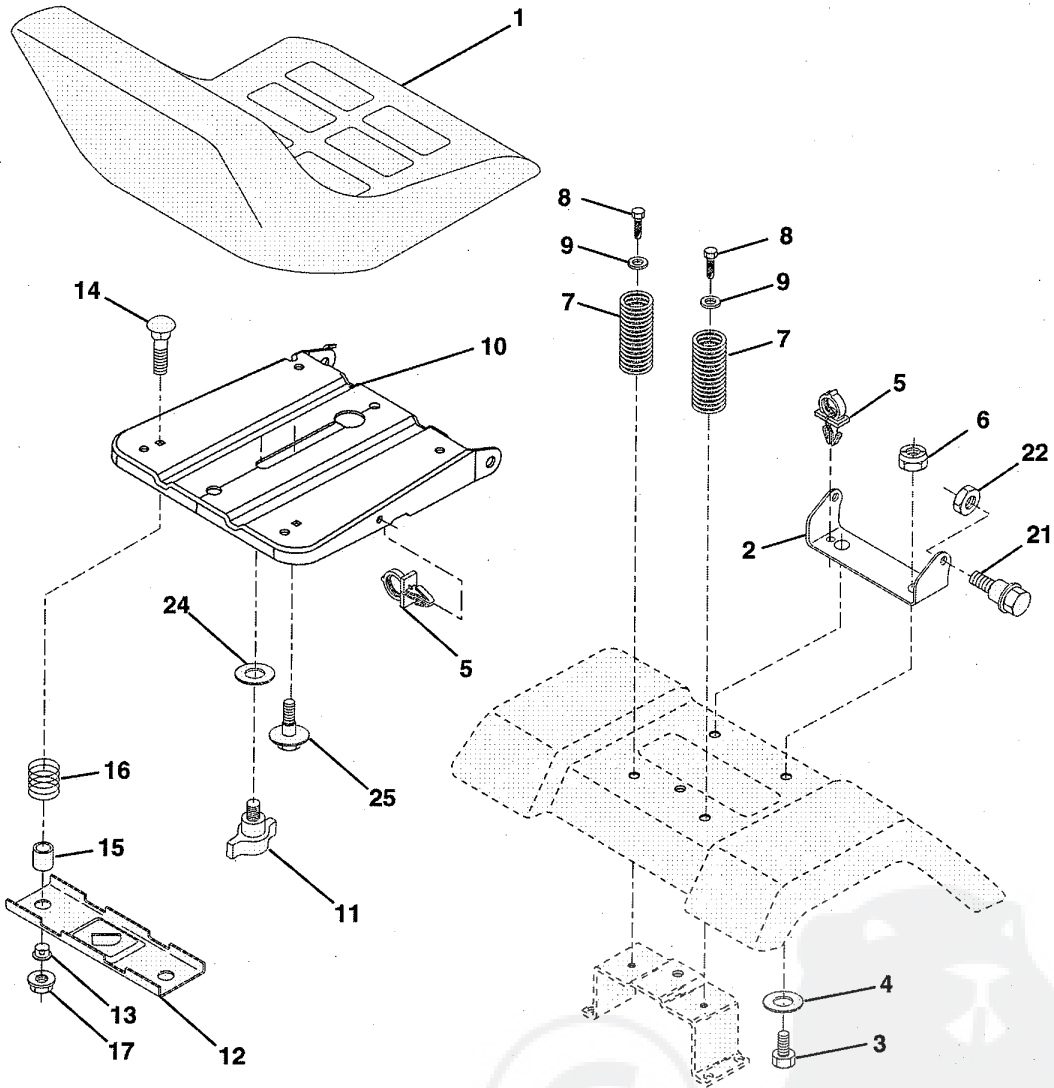

seat_ft.knob_13

KEY NO.	PART NO.	DESCRIPTION
1	188709	Seat
2	140551	Bracket, Pivot, Seat
3	71110616	Bolt
4	19131610	Washer 13/32 x 1 x 10 Ga.
5	145006	Clip, Push-In Hinged
6	STD541437	Nut
7	124181X	Spring, Seat
8	17000616	Screw 3/8-16 x 1-1/2
9	19131614	Washer 13/32 x 1 x 14 Ga.
10	195530	Pan, Seat
11	166369	Knob Seat
12	174648	Bracket, Switch Mounting
13	121248X	Bushing, Snap

KEY NO.	PART NO.	DESCRIPTION
14	72050412	Bolt, Carriage 1/4-20 x 1-1/2
15	134300	Spacer, Split .28 x .88
16	121250X	Spring
17	123976X	Locknut, Flange 1/4 Gr. 5
21	171852	Bolt, Shoulder 5/16-18 unc
22	STD541431	Nut
24	19171912	Washer 17/32 x 1-3/16 x 12 Ga.
25	127018	Bolt Shoulder 5/16-18 x .62

NOTE: All component dimensions give in U.S. inches
1 inch = 25.4 mm

REPAIR PARTS

TRACTOR- -MODEL NO. 917. 257430

DECAL

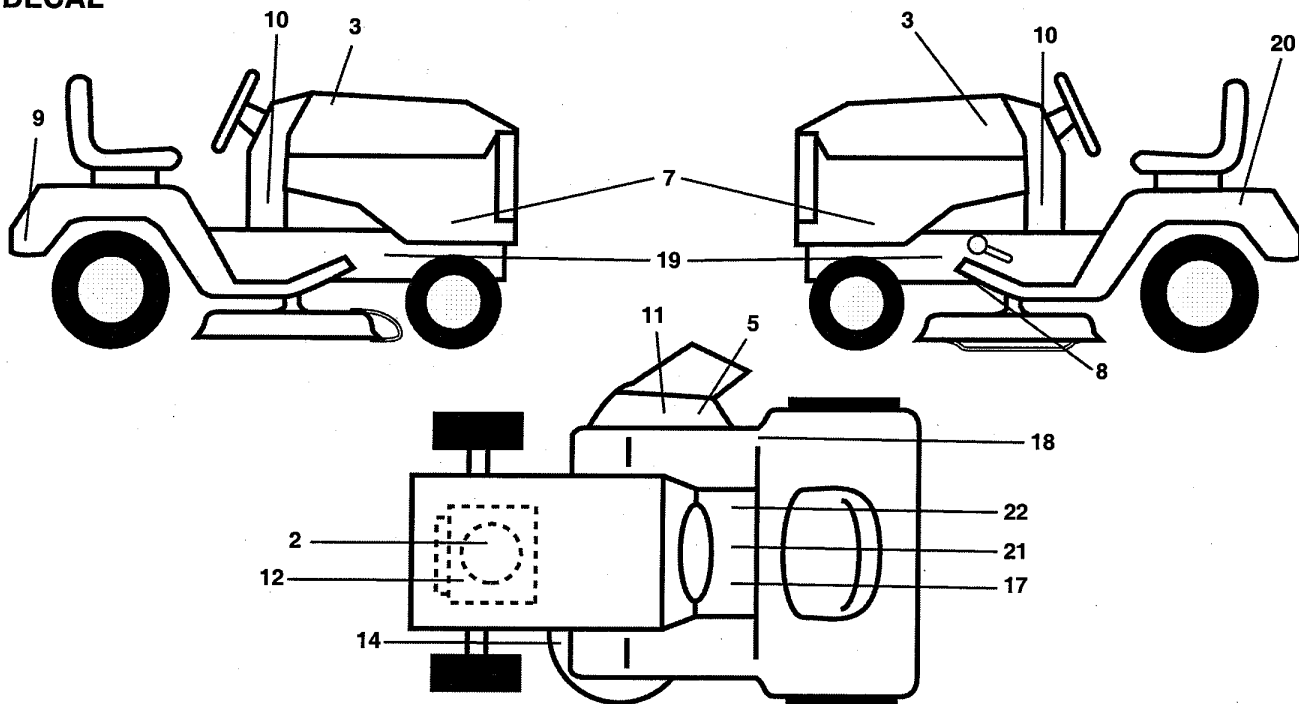

KEY NO.	PART NO.	DESCRIPTION	KEY NO.	PART NO.	DESCRIPTION
2	412646	Decal, HP Engine	20	145005	Decal, Battery Dngr/Psn Eng
3	411697	Decal, Hood RH/LH	21	159737	Decal, Brake/Clutch Sym
5	196357	Decal, Warning	22	140837	Decal, Saddle Brake/Parking
7	404492	Decal, Panel Side	--	138311	Decal, Lift Handle
8	179490	Decal, V-Belt Schematic	--	166960	Decal, Bypass
9	411697	Decal, Fender Hood	--	162598	Decal, Load Limit
10	186787	Decal, Chassis	--	179768X428	Pad Footrest LH
11	182166	Decal, Cutoffinger CE	--	179769X428	Pad Footrest RH
12	196841	Decal, Warning. Sym.	--	413055	Manual, Operator's (Euro)
14	160396	Decal, V-Belt Schematic	--	413056	Manual, Operator's (Scan)
17	400389	Decal, Warning Sym. CE	--	413057	Manual, Operator's (EBloc)
18	180432	Decal, Fender DB/CE	--	413058	Manual, Operator's (Baltic)
19	159736	Decal, Hot Muffler	--	413059	Manual, Parts

WHEELS & TIRES

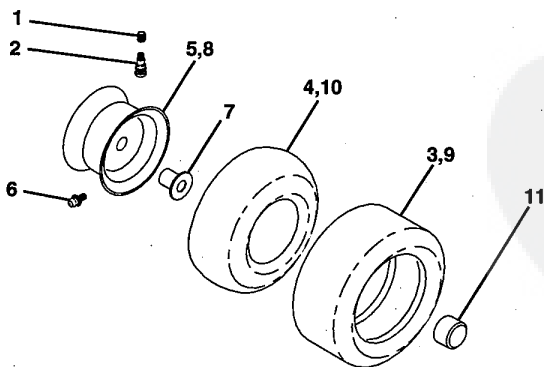

KEY NO.	PART NO.	DESCRIPTION
1	59192	Valve Cap, Tire
2	65139	Stem, Valve
3	106222X	Tire, Front
4	59904	Tube, Front Tire (Not Provided, Service Item Only)
5	106732X624	Rim, Front
6	278H	Fitting, Grease (Front Wheel Only)
7	9040H	Bearing, Flange (Front Wheel Only)
8	106108X624	Rim, Rear
9	106268X	Tire, Rear
10	7152J	Tube, Rear Tire (Not Provided, Service Item Only)
11	104757X428	Cap, Axle
--	144334	Sealant, Tire 10 oz.

NOTE: All component dimensions give in U.S. inches
1 inch = 25.4 mm

REPAIR PARTS

TRACTOR- -MODEL NO. 917. 257430

MOWER

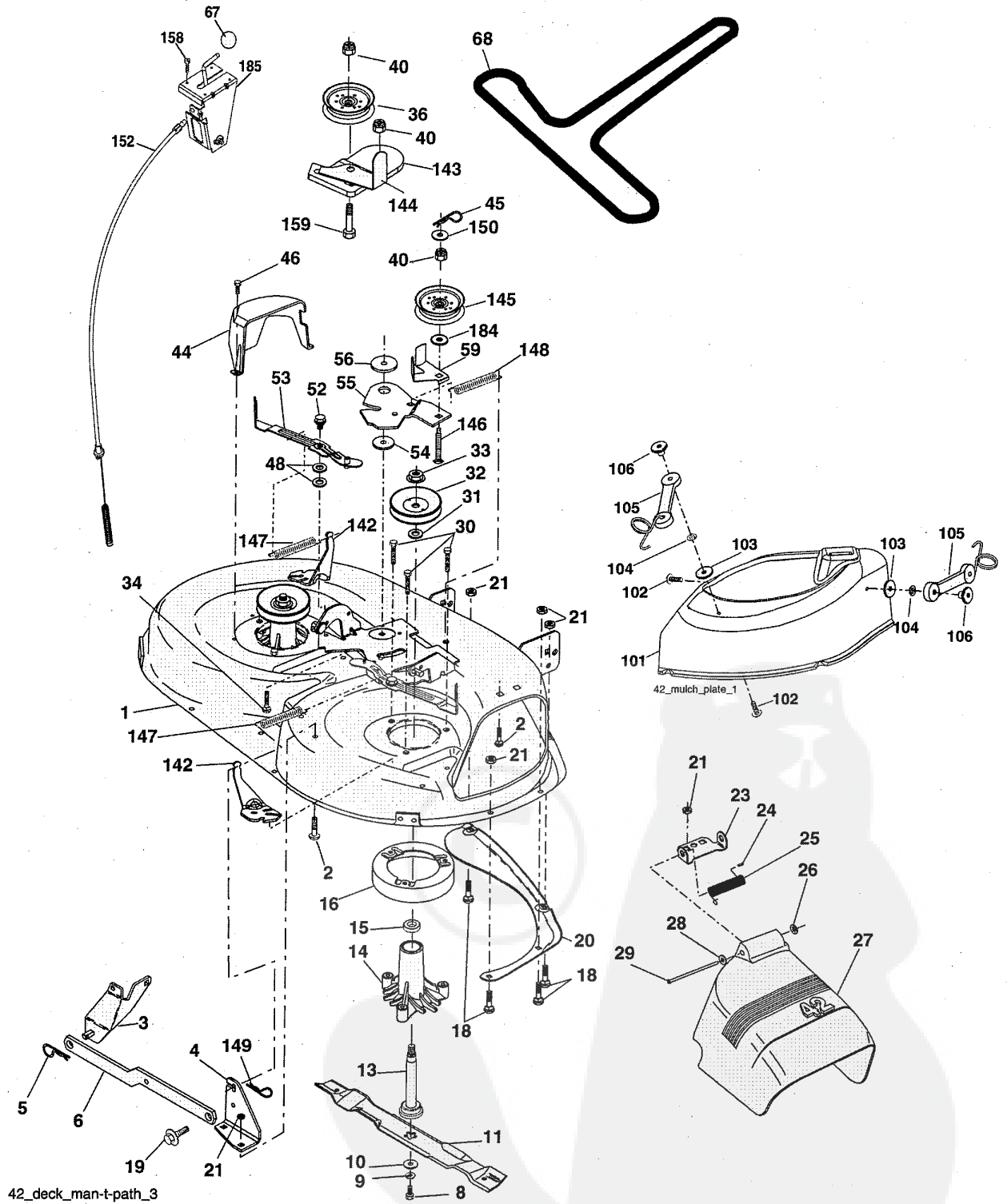

REPAIR PARTS

TRACTOR- -MODEL NO. 917. 257430

MOWER

KEY NO.	PART NO.	DESCRIPTION	KEY NO.	PART NO.	DESCRIPTION
1	165892	Mower Deck Assembly, 42"	45	STD624003	Retainer
2	STD533107	Bolt	46	137729	Screw, Thd. Roll 1/4-20 x 5/8
3	138017	Bracket Assembly, Sway Bar, Front	48	133944	Washer, Hardened
4	165460	Bracket Sway Bar 38/42" eck	52	139888	Bolt, Shoulder 5/16-18 unc
5	STD624008	Retainer Spring	53	184907	Arm Assembly, Pad, Brake
6	178024	Bar Sway Deck	54	178515	Washer, Hardened
8	850857	Bolt, Hex 3/8-24 x 1.25 Gr. 8	55	155046	Arm, Idler
9	STD551137	Washer, Lock	56	165723	Spacer, Retainer
10	140296	Washer, Hardened (The following blades are available)	59	141043	Guard, TUV Idler
11	134149	Blade, Mulching Std. (For mulching mowers only)	67	149846	Knob Custom Oval
--	138971	Blade, 42" Hi-Lift (For bagging or discharging)	68	180215	V-Belt
--	139775	Blade, 42" Mulching Premium (For better wear when mulching)	101	193107	Cover Mulching
13	137645	Shaft Assembly, Mandrel, Vented	102	71081010	Screw Pan Hd Phillip 10-24 x 5/8
14	128774	Housing, Mandrel, Vented	103	19061216	Washer #10
15	110485X	Bearing, Ball, Mandrel	104	10071000	Washer Lock #10
16	174493	Stripper, Mower Deck	105	160793	Latch Asm
18	72140505	Bolt, Carriage 5/16-18 x 5/8	106	2029J	Nut Weid
19	132827	Bolt, Shoulder	142	165890	Arm Spring Brake Mower
20	159770	Baffle, Vortex	143	157109	Bracket Arm Idler 42"
21	STD541431	Nut Crownlock 5/16-18 unc	144	158634	Keeper Belt 42" Clutch Cable
23	177563	Bracket, Deflector	145	165888	Pulley Idler Flat
24	105304X	Cap, Sleeve	146	171977	Bolt Carriage Idler
25	123713X	Spring, Torsion, Deflector	147	179748	Spring Extension
26	110452X	Nut, Push	148	169022	Spring Return Idler
27	130968X428	Shield, Deflector	149	165898	Retainer Spring Yellow Zinc
28	19111016	Washer 11/32 x 5/8 x 16 Ga.	150	19091210	Washer 9/32 x 3/4 x 10 Ga.
29	131491	Rod, Hinge	152	181555	Cable Clutch 42 In
30	173984	Screw Thdrol DOD PT Hex	158	17720408	Screw Hex Thd Cut 1/4-20 x 1/2
31	187690	Washer, Spacer	159	72140614	Bolt Rdhd Sqn 3/8-16 unc x 1-3/4
32	153535	Pulley, Mandrel	184	19131410	Washer 13/32 x 7/8 x 10 Ga.
33	400234	Nut, Toplock, Flanged	185	188234	Head Assy. Cable Clutch
34	72110612	Bolt Carr. Sh. 3/8-16 x 1-1/2 Gr. 5	--	130794	Mandrel Assembly (Includes housing, shaft and shaft hardware only-pulley not included)
36	131494	Pulley, Idler, Flat	--	181268	Replacement Mower, Complete
40	73900600	Nut Lock Fig. 3/8-16 unc			
44	140088	Guard, Mandrel, L.H.			

NOTE: All component dimensions give in U.S. inches
1 inch = 25.4 mm

REPAIR PARTS

TRACTOR- -MODEL NO. 917. 257430

HYDRO TRANSAXLE - MODEL NUMBER 322-0510

Key Part No.	No.	Description	Key Part No.	No.	Description
1	170351	Kit, Main Housing	67	170413	Bolt, Square Head - Brake
		Main Housing, Machined	69	170415	Nut, Castle 5/16-24
		Bushing .865 X .985 X .790	70	170416	Pin, Cotter 3/32x3/4
2	170352	Kit, Side Housing	71	170417	Brake Spring
		Side Housing, Machined	72	170418	Washer (310-0750)
		Bushing .865 X .985 X .790	73	142884	Washer, Flat
		Bushing .624 X .719 X .562	74	170419	Seal, Oil
3	170353	Kit, Center Section	75	170420	Ass'y Check Plug
		Center Section, Machined	76	170421	Bolt, Stud 5/16-24
		Bushing .707 X .788 X .591	77	170422	Puck, Friction
4	170354	Swashplate, Trunnion Machined	78	142969	Spring
5	169898	Kit, Cylinder Block (10cc)	79	142980	Spacer
		Block - Cylinder	80	150778	Nut, Nylon Insert Hex Lock 5/16-24
		Piston	81	170423	Wedge, Friction
		Spring, Compression	82	170424	Clip, Washer
		Washer - Thrust	83	161168	Pin
6	178322	Sealant Tube	84	170425	Fitting, 5/16 X Sae 5/32 Tube
7	170356	Hexflange Screw 1/4-20 X 1.25	85	170426	Hose, Expansion Tank
8	170357	Stud, 5/16-24 Hex Double End	87	173160	Cap, Vent
9	170358	Shaft, Input	88	178334	Bolt, Self Tapping (BDR)
10	170359	Retaining Ring	90	170430	Puck, Inner Wedge
11	170360	Spacer	93	170431	Spring Clip, Housing
12	169870	Retaining Ring	107	170432	Deflector
13	170361	Seal, Lip .67 X 1.58 X .276	108	170433	Washer, Motor Shaft .71ID X 1.15OD X .03 Thick
14	173158	Bearing, Ball 6203 (BDR)	109	170434	Plug, Straight Thread 9/16-18
16	170362	Hex Flange Head Screw 1/4-20 X 1.25	111	170435	O-ring .7 X .301 ID
17	170363	Seal, Lip 18 X 32 X 7	113	170437	Bracket, Support Expansion Tank
18	170364	Arm, Control	119	173161	Fan (310-3000)
19	173159	Bearing, Thrust (10cc)	120	170440	Pulley
23	170365	Check Plug Assembly	121	170441	Hex Nut Locking
24	170366	Shaft Motor	122	173162	Screw, #12-24 Hx Hd Self Tapping (310-3000)
27	170367	Gear, Pinion, 13t	123	173163	Bracket, Belt Keeper
28	170368	10t / 48t Gear	124	170444	Kit, Center Section Filter Bypass
29	170369	Gear, 10t Jackshaft			Center Section Machining
30	170370	60t Bullgear			Base Filter W/ Poppet
31	170371	Sleeve Bearing .75 X 1.75 X .625			Check Plug Assembly, 027 Washer
32	170389	Sleeve Bearing (Outboard) .75 X 1.575 X .625			Check Plug Assembly, Washer
33	142991	Washer			Spring, Bypass
34	170390	Lip Seal, Axle Shaft			Actuator, Bypass
35	170391	Shaft, Axle (Keyed, R.h.)			Deflector
36	170392	Shaft, Axle (Keyed, L.h.)			Bottom, Filter
37	150792	Gear, Splined Diff. (210-1000 & 310-0750)			Bushing .707 X .788 X .591
38	150793	Gear, Miter Diff. (210-1000 & 310-0750)	125	170445	Kit, Filter
39	150809	Differential Shaft (310-0750)			Bottom, Filter
40	170393	Retaining Ring			Spring, Bypass
41	170394	Pin, Jackshaft			Actuator, Bypass
42	170395	Magnet, Ring			Deflector
43	170396	Spring, Bypass			Base, Filter W/ Poppet
44	150797	Bolt 3/8-24 X 2-1/2	126	173164	Kit, Fan / Pulley
45	170397	Filter			#12 T.f. Screw - Indented Hex Washer Head
46	170398	Base, Filter			Fan
47	170399	Actuator, Bypass			Pulley 4.315 X .801
48	170400	Rod, Bypass Actuator	127	170447	Kit, Seal
49	170401	Arm, Bypass			Lip Seal .67 X 1.58 X .276
50	170402	Retaining Ring .25 External			Lip Seal 18 X 32 X 7
51	170403	Seal, Lip .741 X .25 X .25			Lip Seal .706 X 1.584 X .25
52	170404	Washer, Flat 0.050" (210-1000)			Lip Seal .741 X .250 X .250 TC
53	170405	Retaining Ring			Oil Seal 625 X 1.0 X .25
54	170406	Bearing, Center Block			O-ring .07 X .301 ID
55	142977	Spring, Helical Compression	128	173165	Kit, Expansion Tank
56	142978	Washer, Block Thrust			Tank, Expansion
57	----	20w-50 Oil 78.8 Oz			Cap, Vent
58	142929	Kit, Brake Yoke			Bolt, Self Tapping 10-32 X 1/2
59	170408	Rotor, Brake			Bracket, Support Expansion Tank
60	142883	Brake Puck			Silicon Sponge 1/2 X 1/2 X 3/16
61	142882	Brake Puck Plate	129	191032	Cap, Expansion Tank Shipping
62	170409	Pin, Brake Actuating	130	186352	Kit, Brake Arm And Spring
63	170410	HFHCS 1/4-20 X 2 W/patch, Special Flange			Arm, Brake
64	142892	Bolt, Nylok			Spring, Brake Arm Bias
65	170411	Spacer, Brake Torsion Spring	900	171613	Instruction Sheet
					Transaxle

Note: All Component Dimensions Given In U.s. Inches 1 Inch = 25.4 MM

REPAIR PARTS

TRACTOR- -MODEL NO. 917. 257430

BRIGGS & STRATTON ENGINE - - MODEL NUMBER 31C707, TYPE NUMBER 0240-B1

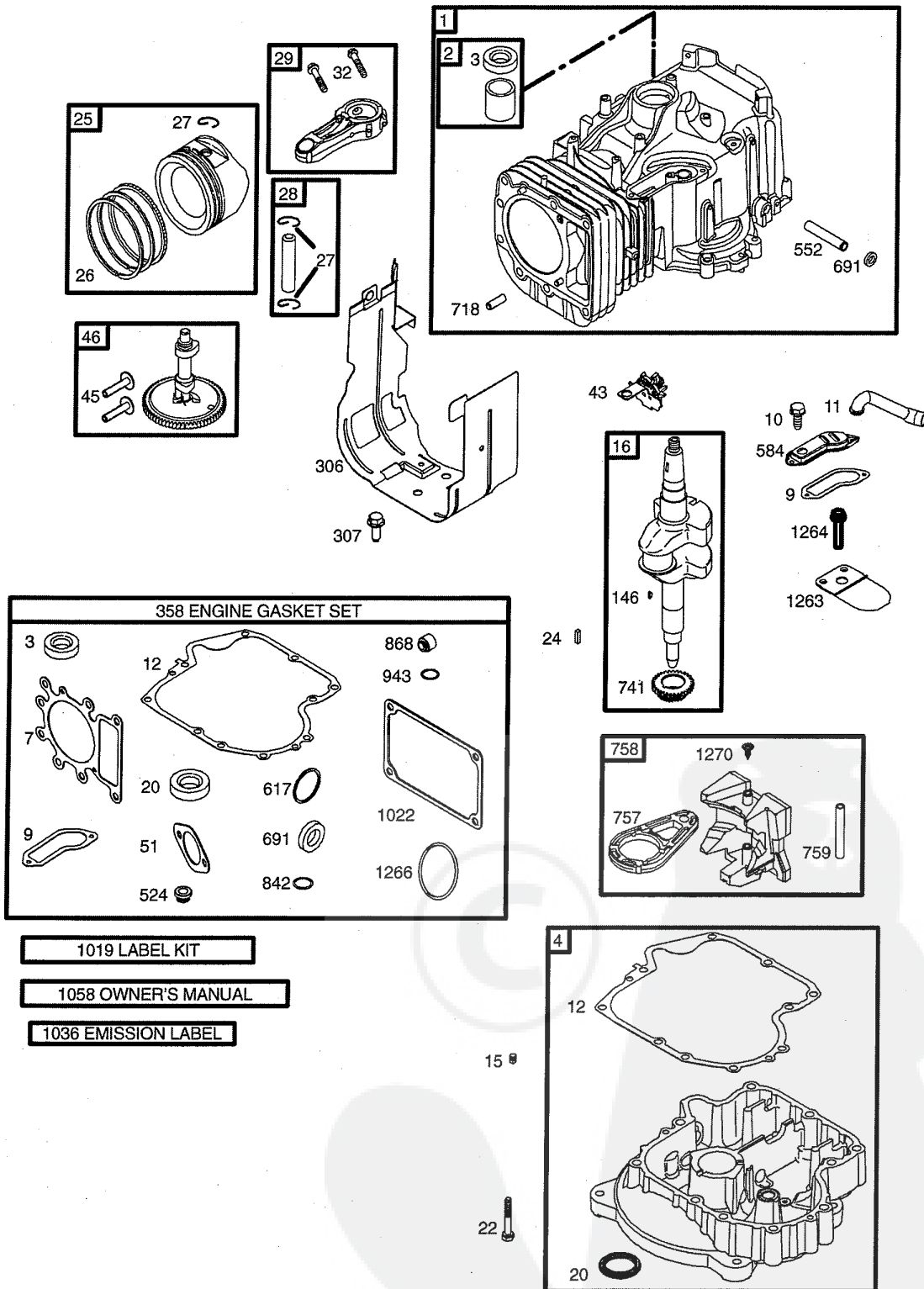

REPAIR PARTS

TRACTOR - - MODEL NO. 917. 257430

BRIGGS & STRATTON ENGINE - - MODEL NUMBER 31C707, TYPE NUMBER 0240-B1

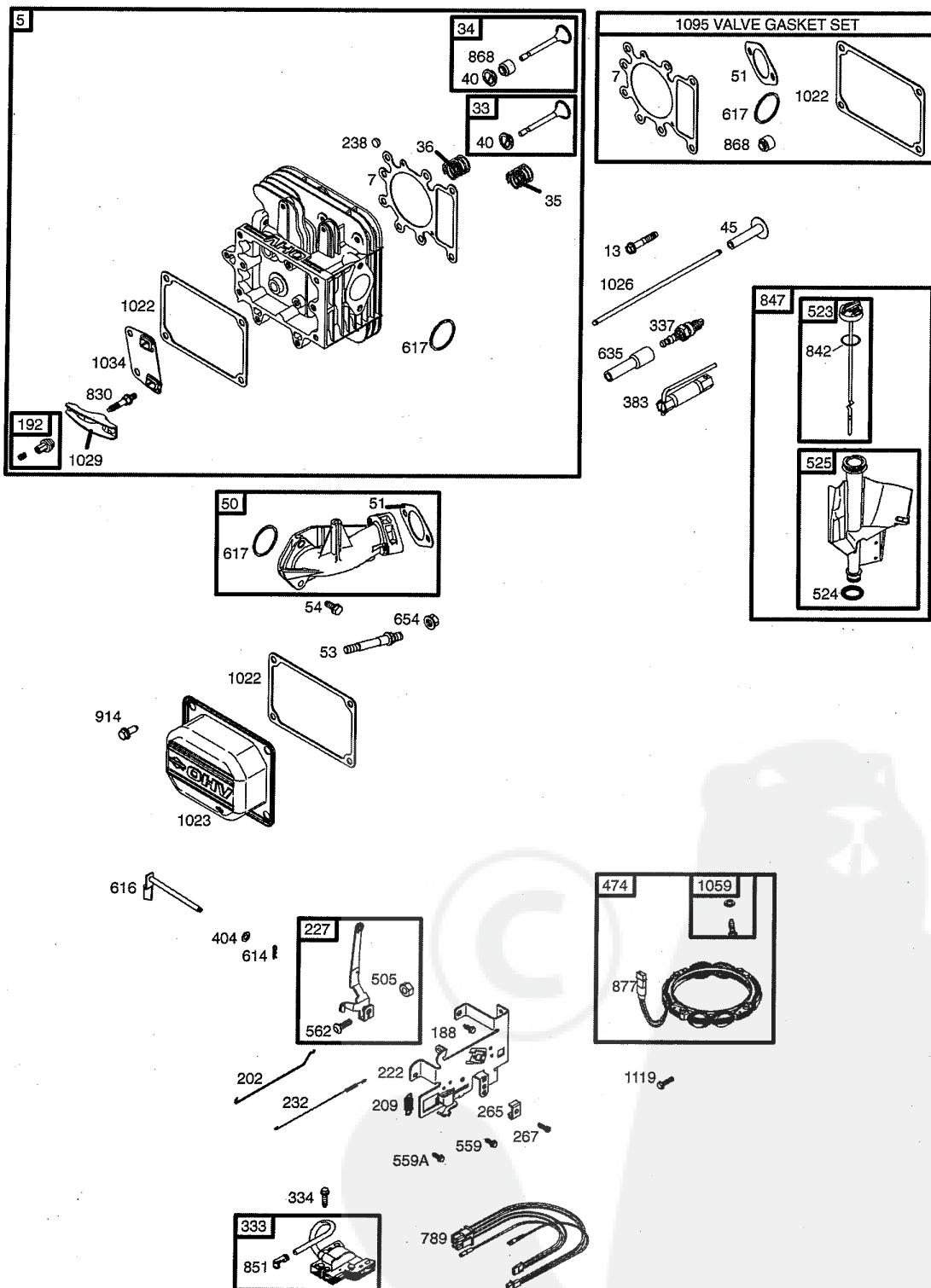

REPAIR PARTS

TRACTOR- -MODEL NO. 917. 257430

BRIGGS & STRATTON ENGINE - - MODEL NUMBER 31C707, TYPE NUMBER 0240-B1

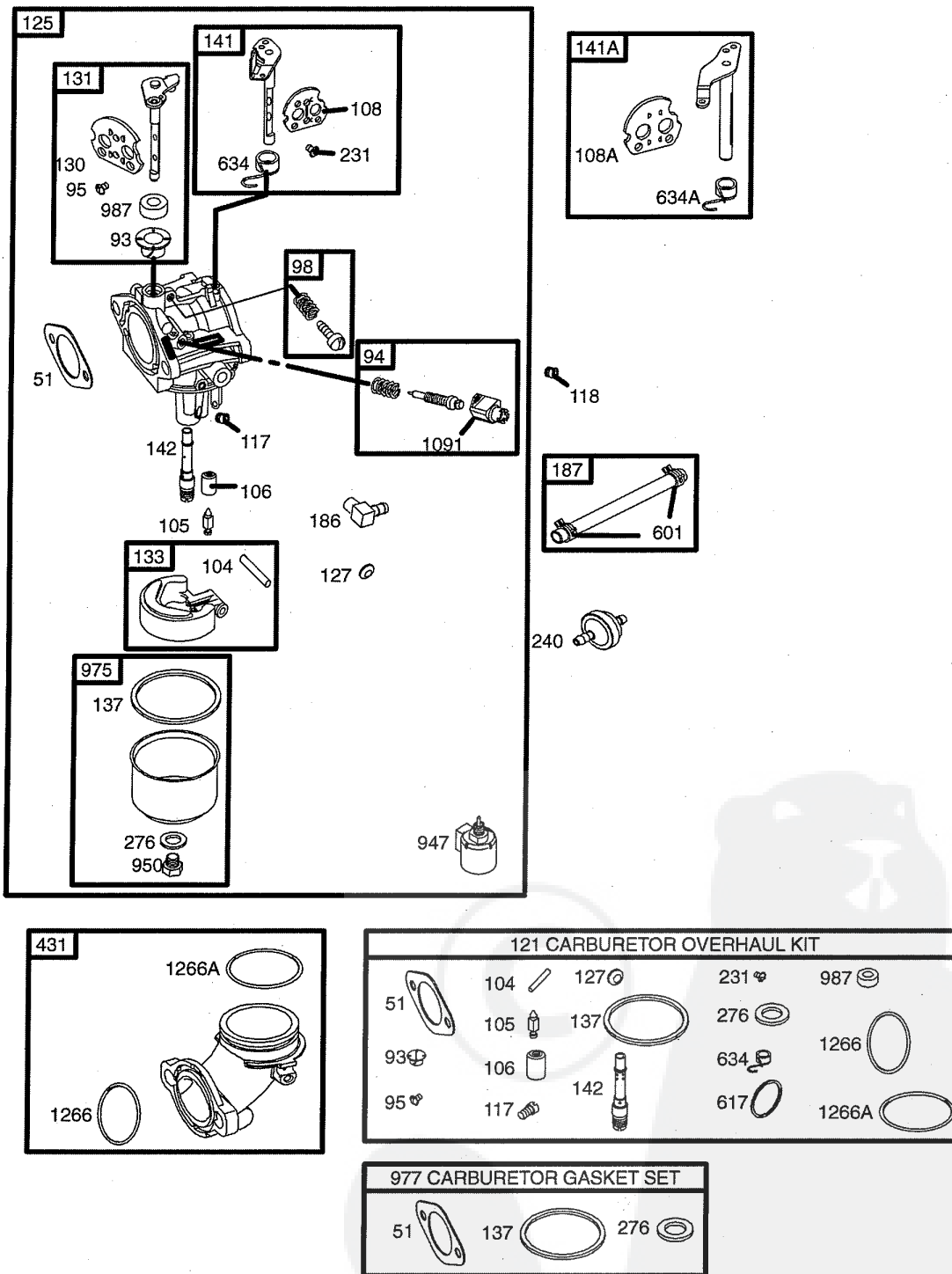

REPAIR PARTS

TRACTOR- -MODEL NO. 917. 257430

BRIGGS & STRATTON ENGINE - - MODEL NUMBER 31C707, TYPE NUMBER 0240-B1

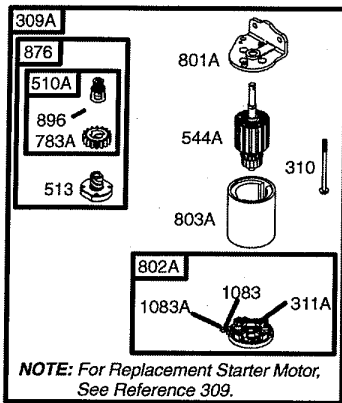
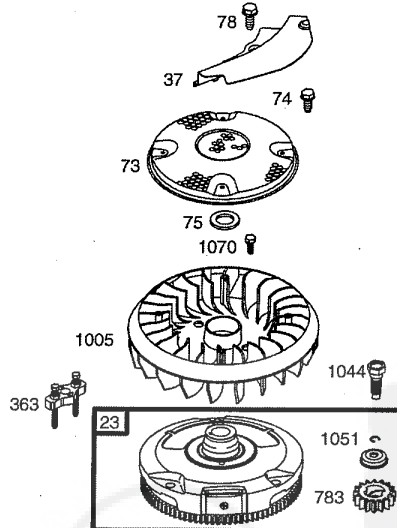
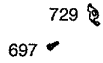
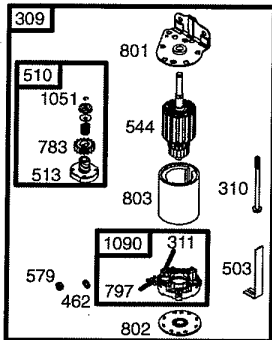
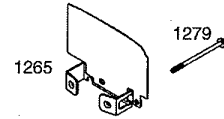
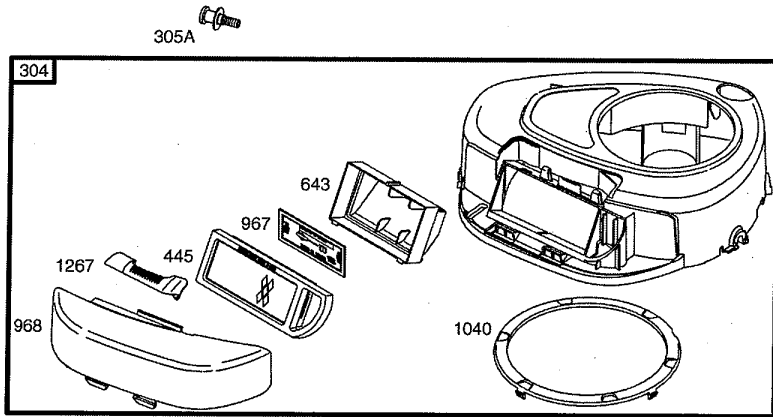

REPAIR PARTS

TRACTOR- -MODEL NO. 917. 257430

BRIGGS & STRATTON ENGINE - - MODEL NUMBER 31C707, TYPE NUMBER 0240-B1

KEY PART NO. NO.	DESCRIPTION	KEY PART NO. NO.	DESCRIPTION
1	697174 Cylinder Assembly	118	697492 Jet-Main (High Altitude)
2	399265 Kit-Bushing/Seal (Magneto Side)	121	697241 Kit-Carburetor Overhaul
3	391086 • Seal-Oil (Magneto Side)	125	697190 Carburetor
4	697106 Sump-Engine	127	695005 Plug-Welch
5	698147 Head-Cylinder	130	691750 Valve-Throttle
7	692410 •+ Gasket-Cylinder Head	131	494379 Kit-Throttle Shaft
9	697109 • Gasket-Breather	133	494381 Float-Carburetor
10	697157 Screw (Breather Assembly)	137	281165Ø‡ Gasket-Float Bowl
11	697113 Tube-Breather	141	495097 Kit-Choke Shaft (Manual Choke)
12	697110 • Gasket-Crankcase	141A	495931 Kit-Choke Shaft (Choke A Matic)
13	690360 Screw (Cylinder Head)	142	697140 Ø Nozzle-Carburetor
15	690946 Plug-Oil Drain	146	691639 Key-Timing
16	697127 Crankshaft	186	692317 Connector-Hose
20	690947 • Seal-Oil (PTO Side)	187	691050 Line-Fuel (Cut to Required Length)
22	692125 Screw (Crankcase Cover/Sump)	188	691693 Screw (Control Bracket)
23	693557 Flywheel	192	691986 Adjuster-Rocker Arm
24	222698 Key-Flywheel	202	691841 Link-Mechanical Governor
25	697159 Piston Assembly (Standard)	209	692208 Spring-Governor
	697160 Piston Assembly (.010" Oversize)	222	694042 Bracket-Control
	697162 Piston Assembly (.020" Oversize)	227	691374 Lever-Governor Control
	697163 Piston Assembly (.030" Oversize)	231	691636 Screw (Choke Valve)
26	697164 Ring Set (Standard)	232	691842 Spring-Governor
	697165 Ring Set (.010" Oversize)	238	691843 Cap-Valve
	697171 Ring Set (.020" Oversize)	240	394358 Filter-Fuel
	697172 Ring Set (.030" Oversize)	265	691024 Clamp-Casing
27	697100 Lock-Piston Pin	267	695134 Screw (Casing Clamp)
28	697099 Pin-Piston	276	692255Ø‡ Washer-Sealing
29	697126 Rod-Connecting (Standard)	304	698402 Housing-Blower
32	692852 Screw (Connecting Rod)	305	697102 Screw (Blower Housing)
33	495856 Valve-Exhaust	305A	697103 Screw (Blower Housing)
34	495857 Valve-Intake	306	697107 Shield-Cylinder
35	691279 Spring-Valve (Intake)	307	691003 Screw (Cylinder Shield)
36	691279 Spring-Valve (Exhaust)	309	693551 Motor-Starter
37	697352 Guard-Flywheel	309A	Motor-Starter (For Replacement Starter Motor, See Reference 309)
40	691752 Retainer-Valve	310	690323 Bolt (Starter Motor)
43	691968 Slinger-Governor/Oil	311	497608 Brush Set
45	690564 Tappet-Valve	311A	395538 Brush Set
46	697687 Camshaft	333	492341 Armature-Magneto
48	697761 Short Block (31C707-0240-E2 Replacement Engine-art not available)	334	691061 Screw (Magneto Armature)
50	690193 Manifold-Intake	337	691043 Plug-Spark
51	692137•Ø‡+ Gasket-Intake	358	697191 Gasket Set-Engine
53	690227 Stud (Carburetor)	363	19203 Flywheel Puller
54	691148 Screw (Intake Manifold)	383	89838 Wrench-Spark Plug
73	697384 Screen-Rotating	404	691691 Washer (Governor Crank)
74	697987 Screw (Rotating Screen)	431	697122 Elbow-Intake
75	690582 Washer (Flywheel)		RPM Settings: Low Speed: 1900-2100
78	691003 Screw (Flywheel Guard)		High Speed: 3000-3200
93	690602 Ø Bushing-Throttle Shaft		
94	498030 Kit-Idle Mixture		
95	691636 Screw (Throttle Valve)		
98	495800 Kit-Idle Speed		
104	690525 Ø Pin-Float Hinge		
105	231855 Ø Valve-Float Needle		
106	690577 Ø Seat-Inlet		
108	690464 Valve-Choke (Manual Choke)		
108A	692344 Valve-Choke (Choke A Matic)		
117	694352 Ø Jet-Main (Standard)		

- Included in Engine Gasket Set, Key. No. 358
- Ø Included in Carburetor Overhaul Kit, Key. No. 121
- ‡ Included in Carburetor Gasket Set, Key. No. 977
- + Included in Valve Gasket Set, Key. No. 1095

NOTE: All component dimensions given in U.S. inches 1 inch = 25.4 mm

REPAIR PARTS

TRACTOR- -MODEL NO. 917. 257430

BRIGGS & STRATTON ENGINE - - MODEL NUMBER 31C707, TYPE NUMBER 0240-B1

KEY PART NO. NO.	DESCRIPTION	KEY PART NO. NO.	DESCRIPTION
445 698083	Filter-Air Cleaner Cartridge	876 495877	Kit-Pinion Spring
462 691261	Washer (Starter Cable)	877 393456	Wire-Connector/Alternator
474 696459	Alternator	896 691641	Pin-Drive Retainer
503 691532	Strap-Starter	914 690960	Screw (Rocker Cover)
505 691251	Nut (Governor Control Lever)	947 694393	Solenoid-Fuel
510 693699	Drive-Starter	950 691657	Screw (Float Bowl)
510A 497606	Drive-Starter	967 697015	Filter-Pre Cleaner
513 692024	Clutch-Drive	968 698403	Cover-Air Cleaner
523 697086	Dipstick	975 495933	Bowl-Float
524 691032	• Seal-Dipstick Tube	977 690192	Gasket Set-Carburetor
525 697184	Tube-Dipstick	987 691326 Ø	Seal-Throttle Shaft
544 692034	Starter-Armature	1005 697853	Fan-Flywheel
544A 390837	Starter-Armature	1019 697143	Kit-Label
552 697144	Bushing-Governor Crank	1022 272475 *+	Gasket-Rocker Cover
559 697561	Screw (Remote Choke Stop)	1023 692492	Cover-Rocker Arm
559A 693675	Screw (Remote Choke Stop)	1026 692003	Rod-Push (Intake)
562 691119	Bolt (Governor Control Lever)	692011	Rod-Push (Exhaust)
579 691029	Nut (Starter Cable)	1029 691751	Arm-Rocker
584 697112	Cover-Breather Passage	1034 690822	Guide-Push Rod
601 95162	Clamp-Hose	1036 695700	Label-Emission
614 691620	Pin-Cotter	1040 698368	Plate-Trim
616 692012	Crank-Governor	1044 691658	Screw (Flywheel)
617 692138 Ø	• Seal-O Ring (Intake Manifold)	1051 691265	Ring-Retaining
634 690801 Ø	Spring/Seal Assembly (Manual Choke)	1058 275038	Owner's Manual
634A 690802 Ø	Spring/Seal Assembly (Choke A Matic)	1059 698516	Kit-Screw/Washer
635 691909	Boot-Spark Plug	1070 690372	Screw (Flywheel Fan)
643 698401	Retainer-Air Filter	1083 691626	Nut (Starter Terminal)
654 690958	Nut (Carburetor)	1083A690958	Nut (Starter Terminal)
691 692407	• Seal-Governor Shaft	1090 691293	Retainer-Brush
697 690372	Screw (Drive Cap)	1091 691333	Cap-Limiter
718 690959	Pin-Locating	1095 690190	Gasket Set-Valve
729 691224	Clip-Wire	1119 691183	Screw (Alternator)
741 697128	Gear-Timing	1263 697124	Reed-Breather
757 697607	Link-Counterweight	1264 697104	Screw (Breather Reed)
758 697134	Counterweight	1265 697125	Support-Blower Housing
759 697392	Pin-Counterweight	1266 691917 Ø	Seal-O Ring (Intake Elbow)
783 693713	Gear-Pinion	1266A697123 Ø	Seal-O Ring (Intake Elbow)
783A 693059	Gear-Pinion	1267 697575	Latch-Blower Housing
789 698329	Harness-Wiring	1270 697156	Plug-AVS Counterweight
797 693167	Nut (Brush Retainer)	1279 690960	Screw (Blower Housing Support)
801 691283	Cap-Drive	RPM Settings:	Low Speed: 1900-2100
801A 394856	Cap-Drive		High Speed: 3000-3200
802 691286	Cap-End		
802A 395537	Cap-End		
803 693757	Housing-Starter		
803A 398159	Housing-Starter		
830 691095	Stud (Rocker Arm)		
842 691031	• Seal-O Ring (Dipstick Tube)		
847 697611	Dipstick/Tube Assembly		
851 692424	Terminal-Spark Plug		
868 690968 *+	Seal-Valve		

- Included in Engine Gasket Set, Key. No. 358
- Ø Included in Carburetor Overhaul Kit, Key. No. 121
- ‡ Included in Carburetor Gasket Set, Key. No. 977
- + Included in Valve Gasket Set, Key. No. 1095

NOTE: All component dimensions given in U.S. inches 1 inch = 25.4 mm

LIMITED WARRANTY ON CRAFTSMAN TRACTOR AND BATTERY

2-YEAR ON TRACTOR

When used and maintained according to the operator's manual instructions, if this tractor fails due to a defect in material or workmanship within two years from the date of purchase, call 1-800-4-MY-HOME® to arrange for free repair.

During the first 30 days of purchase, there will be no charge to service the product in your home. For your convenience, in-home warranty service will still be available after the first 30 days of purchase, but a trip charge will apply. This charge will be waived if you transport the product to an authorized Craftsman drop-off location. For the nearest authorized location, call 1-800-4-MY-HOME®.

Tractor warranty coverage does not include:

- Expendable items which become worn during normal use, including but not limited to blades, spark plugs, air cleaners, belts, and oil filters.
- Standard maintenance servicing, oil changes, or tune-ups.
- Tire replacement or repair caused by punctures from outside objects, such as nails, thorns, stumps, or glass.
- Repairs necessary because of operator abuse, including but not limited to damage caused by towing objects beyond the capability of the tractor, impacting objects that bend the frame or crankshaft, or over-speeding the engine.
- Repairs necessary because of operator negligence, including but not limited to electrical and mechanical damage caused by improper storage, failure to use the proper grade and amount of engine oil, failure to keep the deck clear of flammable debris, or failure to maintain the equipment according to the instructions contained in the operator's manual.
- Engine (fuel system) cleaning or repairs necessary because of fuel determined to be contaminated or oxidized (stale). In general, fuel should be used within 30 days of its purchase date.
- Normal deterioration and wear of the exterior finishes, or product label replacement.
- The tractor battery, which is covered for only 90 days as stated below.

90-DAYS ON BATTERY

For ninety (90) days from the date of purchase, if the battery included with this tractor is defective in material or workmanship (our testing proves it will not hold a charge), it will be replaced free of charge.

During the first 30 days of purchase, there will be no charges to replace the battery in your home. For your convenience, in-home warranty service will still be available after the first 30 days of purchase, but a trip charge will apply. This charge will be waived if you transport the battery to an authorized Craftsman drop-off location. For the nearest authorized location, call 1-800-4-MY-HOME®.

All tractor and battery warranty coverage is void if this product is used for commercial or rental purposes.

This warranty applies only while this product is within the United States.

This warranty gives you specific legal rights, and you may also have other rights, which vary, from state to state.

Sears, Roebuck and Co., Dept. 817WA, Hoffman Estates, IL 60179



CRAFTSMAN®