

REPAIR PARTS MANUAL
MODEL NO. 274261
Lawn Tractor

CRAFTSMAN®

HOW TO USE THIS MANUAL

This manual is designed to provide the customer with a means to identify the parts on his/her tractor when ordering repair parts. The illustrations may or may not represent the actual assemblies; therefore, it is not recommended to use this manual as a guide to assemble or disassemble the tractor. Some hardware and parts are drawn larger in order to more readily identify them.

Each tractor has its own model number.

The model number for your tractor can be found on the fender under the seat.

When ordering parts, always give the following information:

- Product - "Tractor"
- Model Number - "274261"
- Part Number
- Part Description

TABLE OF CONTENTS

SCHEMATIC	3
ELECTRICAL.....	4-5
CHASSIS.....	6
STEERING	7
DRIVE.....	8-9
ENGINE.....	10
SEAT	11
DECALS.....	12
MOWER LIFT	13
MOWER DECK	14-15
TRANSAXLE.....	16-17
ENGINE BREAKDOWN.....	18-22
WARRANTY	23

REPAIR PARTS

TRACTOR- -MODEL NO. 917. 274261

ELECTRICAL

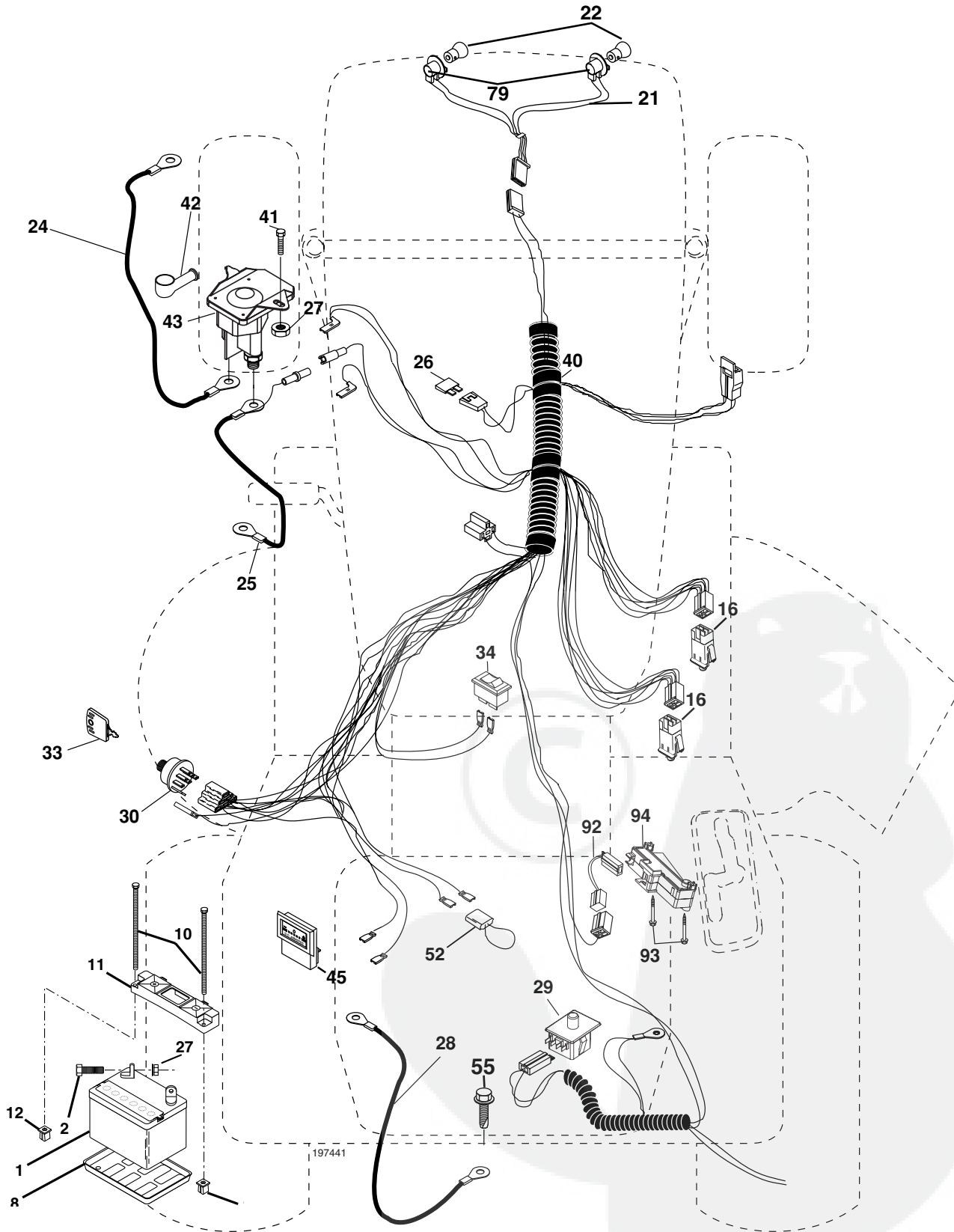

REPAIR PARTS

TRACTOR- -MODEL NO. 917. 274261

ELECTRICAL

KEY NO.	PART NO.	DESCRIPTION
1	144927	Battery
2	74760412	Bolt Hex Hd 1/4-20 unc x 3/4
8	7603J	Battery Tray
10	145211	Bolt Battery 1/4-20 x 7.5
11	150109	Holddown Battery
12	145769	Nut Push 1/4"
16	176138	Switch, Interlock
21	175688	Harness Asm Light W/4152j
22	4152J	Bulb Light #1156
24	8860R	Cable Battery
25	146148	Cable Battery
26	175158	Fuse
27	73510400	Nut Keps Hex 1/4-20 unc
28	145491	Cable Ground 6 Ga. 12" black
29	192749	Switch Seat
30	193350	Switch Ignition
33	140403	Key Ignition
34	110712X	Switch Light
40	197441	Harness Ignition
41	17720408	Screw 1/4-20 x 1/2
42	131563	Cover Terminal Red
43	192507	Solenoid
45	121433X	Ammeter
52	141940	Protection Wire Loop
55	17490508	Screw 5/16-18 x 1/2
79	175242	Socket Asm Bulb
92	196615	Harness Pigtail Console ROS
93	192540	Screw Plastic 10-14 x 2.0
94	191834	Module Reverse ROS

NOTE: All component dimensions given in U.S. inches
1 inch = 25.4 mm

REPAIR PARTS

TRACTOR- -MODEL NO. 917. 274261

CHASSIS AND ENCLOSURES

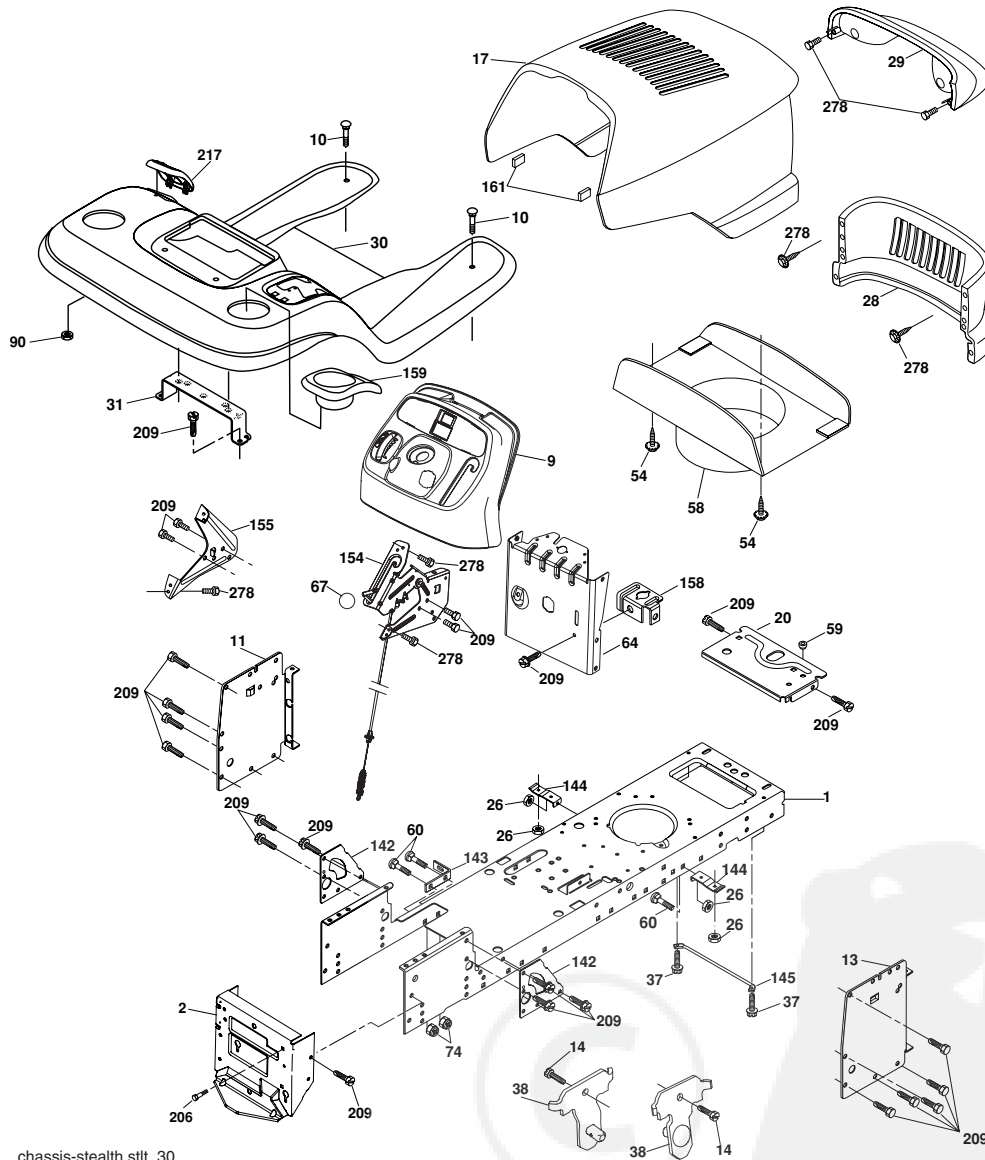

KEY NO.	PART NO.	DESCRIPTION
1	174619	Chassis
2	176554	Drawbar
9	193611X428	Dash
10	72140608	Bolt RDHD SQNK 3/8-16 x 1
11	167203	Panel, Dash, LH
13	188702X010	Panel, Dash, RH
14	17490608	Screw Thdrol 3/8-16 x 1/2
17	175260X615	Hood Assembly
20	162026	Plate Battery
26	STD541437	Locknut, Hex, with Insert 3/8-16 unc
28	174515X615	Grille
29	161840	Lens Bar
30	192395X615	Fender/Foostrest
31	139976	Bracket, Fender/Support
37	17490508	Screw, Thdrol. 5/16-18 x 1/2 TYT
38	175710	Bracket Asm Pivot Mower Rear
54	192512	Screw Wshd Hex 10-32 x 5/8
58	175351	Duct Hood
59	187495	Bushing
60	STD533707	Bolt Rdhd Sqnk 3/8-16 unc x 3/4

KEY NO.	PART NO.	DESCRIPTION
64	174997	Dash Lower
67	106932X	Knob
74	STD541437	Nut Crownlock 3/8-16 unc
90	124346X	Nut
142	175702	Plate Reinforcement
143	186689	Bracket Swaybar Chassis
144	175582	Bracket Footrest
145	156524	Rod Pivot Chassis/Hood
154	192413	Clutch Asm Bracket
155	161900	Bracket Dash Lh
158	162037	Parking Brake Bkrt
159	191120X428	Cupholder
161	164655	Bumper
206	170165	Bolt Shoulder 5/16-18
209	17000612	Screw Hexwsh Thdr 3/8-16 x 3/4
217	179132X428	Console Fuel Window
278	191611	Screw 10 x 3/4 Single Lead Hex

NOTE: All component dimensions given in U.S. inches
1 inch = 25.4 mm

REPAIR PARTS

TRACTOR- -MODEL NO. 917. 274261

STEERING ASSEMBLY

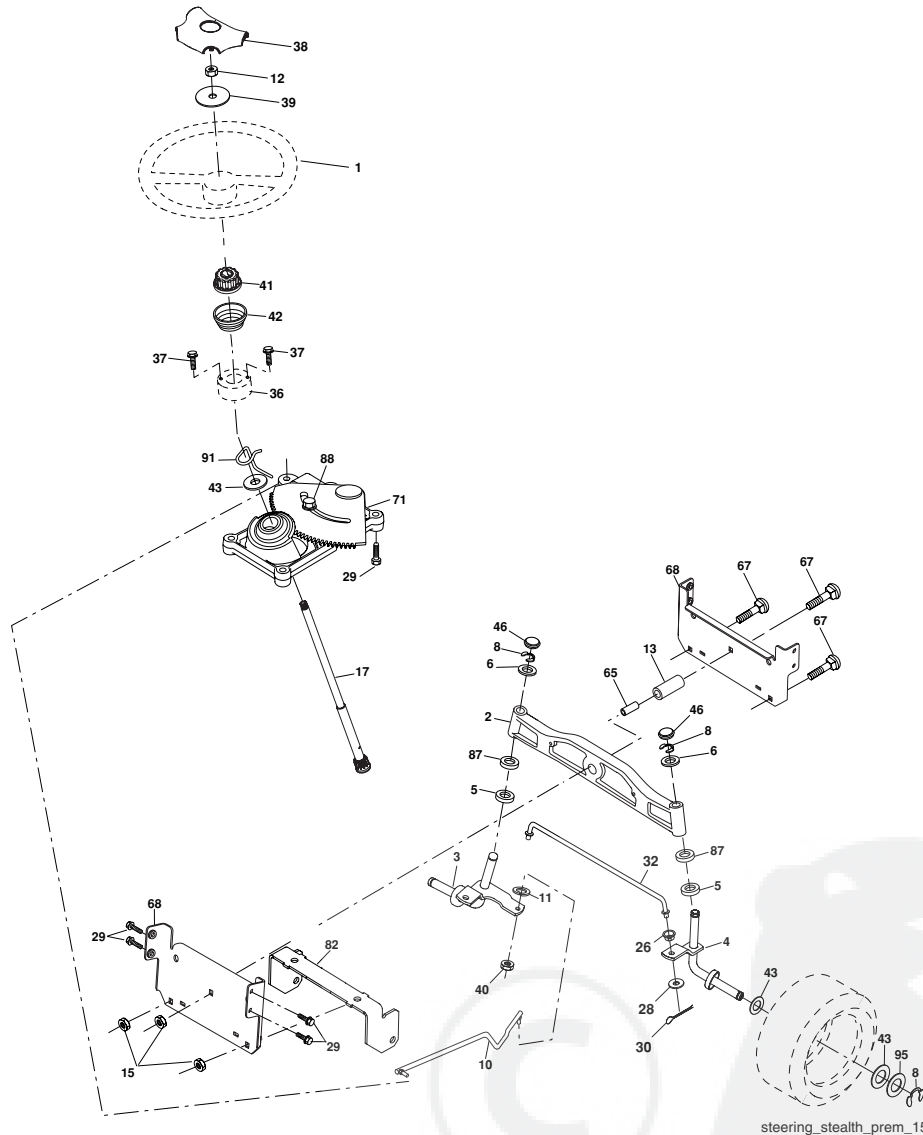

steering_stealth_prem_15

KEY NO.	PART NO.	DESCRIPTION	KEY NO.	PART NO.	DESCRIPTION
1	186093X428	Steering Wheel	36	155105	Bushing, Steering
2	184706	Axle Assembly	37	152927	Screw
3	169840	Spindle Assembly, L.H.	38	186095X428	Insert, Steering Wheel
4	169839	Spindle Assembly, R.H.	39	19183812	Washer 9/16 x 2-3/8 12 Ga.
5	6266H	Washer Thrust	40	73540600	Nut Crownlock 3/8-24
6	121748X	Washer 25/32 x 1-5/8 x 16 Ga.	41	186737	Adaptor, Steering Wheel
7	19272016	Washer 27/32 x 1-1/4 x 16 Ga.	42	163888X428	Boot, Steering Shaft
8	1200029	Ring, Klip	43	121749X	Washer 25/32 x 1-1/4 x 16 Ga.
9	3366R	Bearing Col.	46	184946X505	Cap, Spindle
10	175121	Draglink	65	160367	Spacer Brace Axle
11	STD551137	Washer, Lock	67	72110618	Bolt RDHD Sqnk 3/8-16 x 2-1/4
12	73940800	Nut Hex Jam Toplock 1/5-20 unf	68	169827	Axle, Brace
13	136518	Spacer Bearing Axle Front	71	175146	Steering Asm.
15	145212	Nut, Hex Flange Lock	82	199978	Bracket Susp. Chassis Front
17	177883	Shaft, Steering	87	173966	Washer Flat
26	126847X	Bushing, Link, Drag	88	175118	Bolt Shoulder 7/16-20 unc
28	19131416	Washer 13/32 x 7/8 x 16 Ga.	91	175553	Clip Steering
29	17000612	Screw 3/8-16 x 3/4	95	188967	Washer Hardened
30	STD561210	Pin Cotter			
32	192757	Rod, Tie			

NOTE: All component dimensions given in U.S. inches 1 inch = 25.4 mm

REPAIR PARTS

TRACTOR- -MODEL NO. 917. 274261

DRIVE

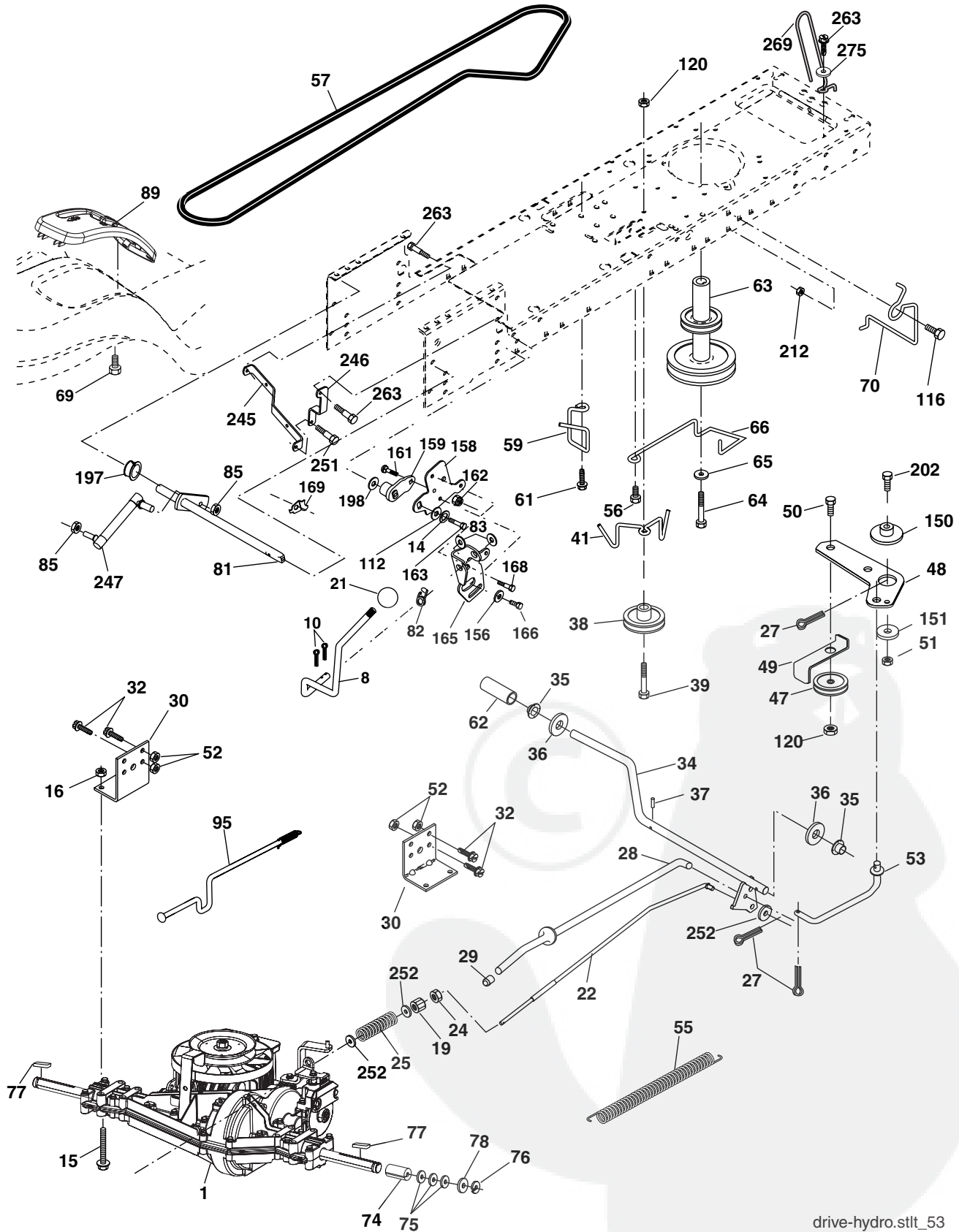

drive-hydro.stlt_53

REPAIR PARTS

TRACTOR- -MODEL NO. 917. 274261

DRIVE

KEY NO.	PART NO.	DESCRIPTION	KEY NO.	PART NO.	DESCRIPTION
1	-----	Transaxle Peerless LTH2000 (See Breakdown)	70	180218	Keeper Belt Engine
8	192502	Rod Shift Fender Adjust	74	137057	Spacer
10	STD561210	Pin Cotter 1/8 x 1 CAD	75	121749X	Washer 25/32 x 1-1/4 x 16 Ga.
14	10040400	Washer Lock Hvy Helical	76	STD581075	E-Ring
15	74490544	Bolt Hex FLGHD 5/16-18 Gr.5	77	123583X	Key, Square
16	STD541431	Nut Lock Hex W/Ins. 5/16-18 unc	78	121748X	Washer 25/32 x 1-5/8 x 16 Ga.
19	STD541437	Nut Lock Hex W/Wsh 3/8-16 unc	81	178139	Shaft Asm Cross Tapered
21	130564	Knob	82	165711	Spring Torsion
22	178141	Rod, Brake	83	19171216	Washer 17/32 x 3/4 x 16 Ga.
24	73350600	Nut, Hex Jam 3/8-16 unc	85	150360	Nut Lock Center 1/4-28 FNTHD
25	106888X	Spring, Brake Rod	89	192387X428	Console, Shift
27	STD561210	Pin Cotter 1/8 x 3/4 CAD.	95	178134	Disconnect Asm Rod Bypass LTH
28	175765	Rod, Parking Brake	112	19091210	Washer 9/32 x 3/4 x 10 Ga.
29	124236X	Cap, Parking Brake	116	72140608	Bolt Rdhd Sqneck 3/8-16 x 1
30	169592	Bracket, Transaxle	120	73900600	Nut Lock Flg 3/8-16
32	74760512	Bolt Hex Hd 5/16-18 unc x 3/4	150	175456	Spacer Retainer
34	175578	Shaft, Foot Pedal	151	19133210	Washer 13/32 x 2 x 10 Ga.
35	120183X	Bearing, Nylon	156	166002	Washer Srrted 5/16 ID x 1.125
36	19211616	Washer	158	165589	Bracket Shift Mount
37	1572H	Pin, Roll	159	183900	Hub Shift
38	179114	Pulley, Composite	161	72140406	Bolt Rdhd Sqnk 1/4-20 x 3/4 Gr. 5
39	72110622	Bolt Rdhd 3/8-16 unc x 2-3/4 Gr. 5	162	73680400	Nut Crownlock 1/4-20 unc
41	175556	Keeper, Belt Idler	163	74780416	Bolt Hex Fin 1/4-20 unc x 1 Gr. 5
47	127783	Pulley, Idler, V-Groove	165	165623	Bracket Pivot Lever
48	154407	Bellcrank, Clutch	166	17490510	Screw 5/16-18 x 5/8
49	123205X	Retainer, Belt	168	165492	Bolt Shoulder 5/16-18 x .561
50	72110612	Bolt Carr Sh 3/8-16 x 1-1/2 Gr 5	169	165580	Plate Fastening
51	STD541437	Nut Crownlock 3/8-16 unc	197	169613	Nyliner Snap-In 5/8"ID
52	STD541431	Nut, Crownlock 5/16-18 unc	198	169593	Washer Nyl 7/8 ID x .105" Hyd
53	199652	Link, Clutch	202	72110614	Bolt Carr Sh 3/8-16 x 1-3/4 Gr.5
55	105709X	Spring, Return, Clutch	212	145212	Nut Hex Flange Lock
56	17060620	Screw 3/8-16 x 1-1/4	245	178122	Strap Torque Lh LTH2000
57	178138	V-Belt	246	178121	Strap Torque Rh LTH2000
59	169691	Keeper, Center Span	247	181462	Link Shift Transaxle LTH2000
61	17120614	Screw 3/8-16 x .875	250	17060612	Screw 3/8-16 x .75
62	123533X	Cover, Pedal	251	17060516	Screw 5/16-18 x 1
63	180219	Pulley, Engine	252	19131616	Washer 13/32 x 1 x 16 Ga.
64	173937	Bolt Hex 7/16-20 x 4 Gr. 5	263	17000612	Screw Hex Wsh Thdr 3/8-16 x 3/4
65	STD551143	Washer			
66	154778	Keeper Belt Engine Hydro			
69	142432	Screw Hex Wsh Hi-Lo 1/4-1/2 unc			

NOTE: All component dimensions given in U.S. inches
1 inch = 25.4 mm

REPAIR PARTS

TRACTOR- -MODEL NO. 917. 274261

ENGINE

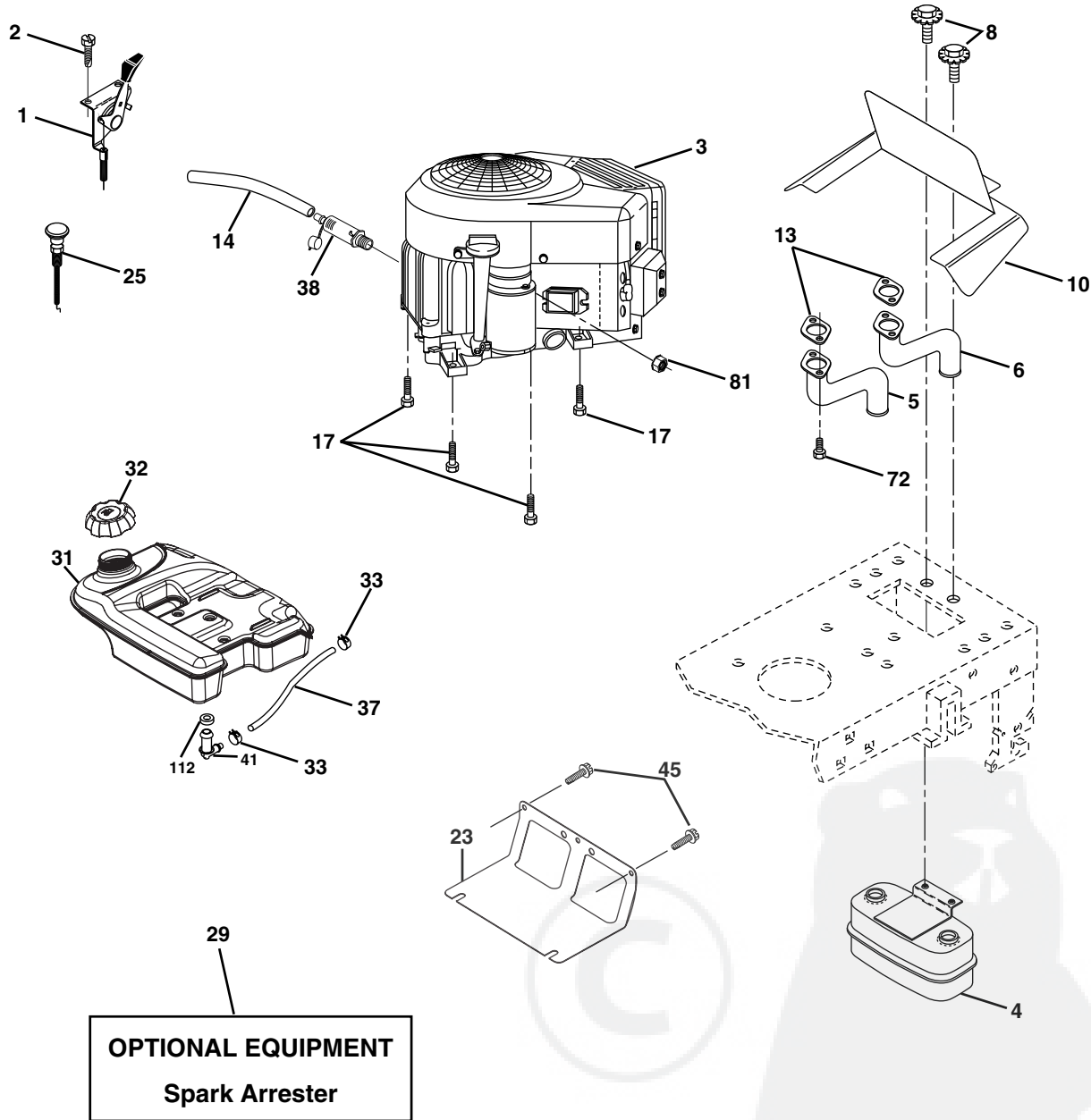

OPTIONAL EQUIPMENT
Spark Arrester

engine-bs intek-twin_39

KEY NO.	PART NO.	DESCRIPTION	KEY NO.	PART NO.	DESCRIPTION
1	175437X505	Control, Throttle/Choke	29	137180	Arrestor, Spark
2	191611	Screw, Hex Head, Thread Cutting 1/4-20 x 1/2	31	179022	Tank, Fuel
3	-----	Engine, Briggs Model 441777-0651-B1	32	179124X428	Cap Assembly, Fuel Sears, Vented
4	149723	Muffler	33	123487X	Clamp, Hose
5	159955	Exhaust Tube RH	37	8543R	Fuel Line
6	160589	Exhaust Tube LH	38	181654	Plug Drain Oil Easy
8	171877	Bolt 5/16-18 UNC x 3/4 w/Sems	41	139277	Stem Tank Fuel
10	162797	Shield, Browning	45	1700612	Screw Hxwsh Thdr 3/8-16 x 3/4
13	165391	Gasket	72	183906	Screw Socket Head 5/16-18 x 1
14	148456	Tube Drain Oil Easy	81	73510400	Nut Keps Hex 1/4-20
17	17060624	Screw 3/8-16 x 1-1/4	112	3645J	Bushing
23	169837	Shield Brn/Dbn Guard			
25	187767X505	Control Choke			

NOTE: All component dimensions given in U.S. inches 1 inch = 25.4 mm

REPAIR PARTS

TRACTOR- -MODEL NO. 917. 274261

SEAT ASSEMBLY

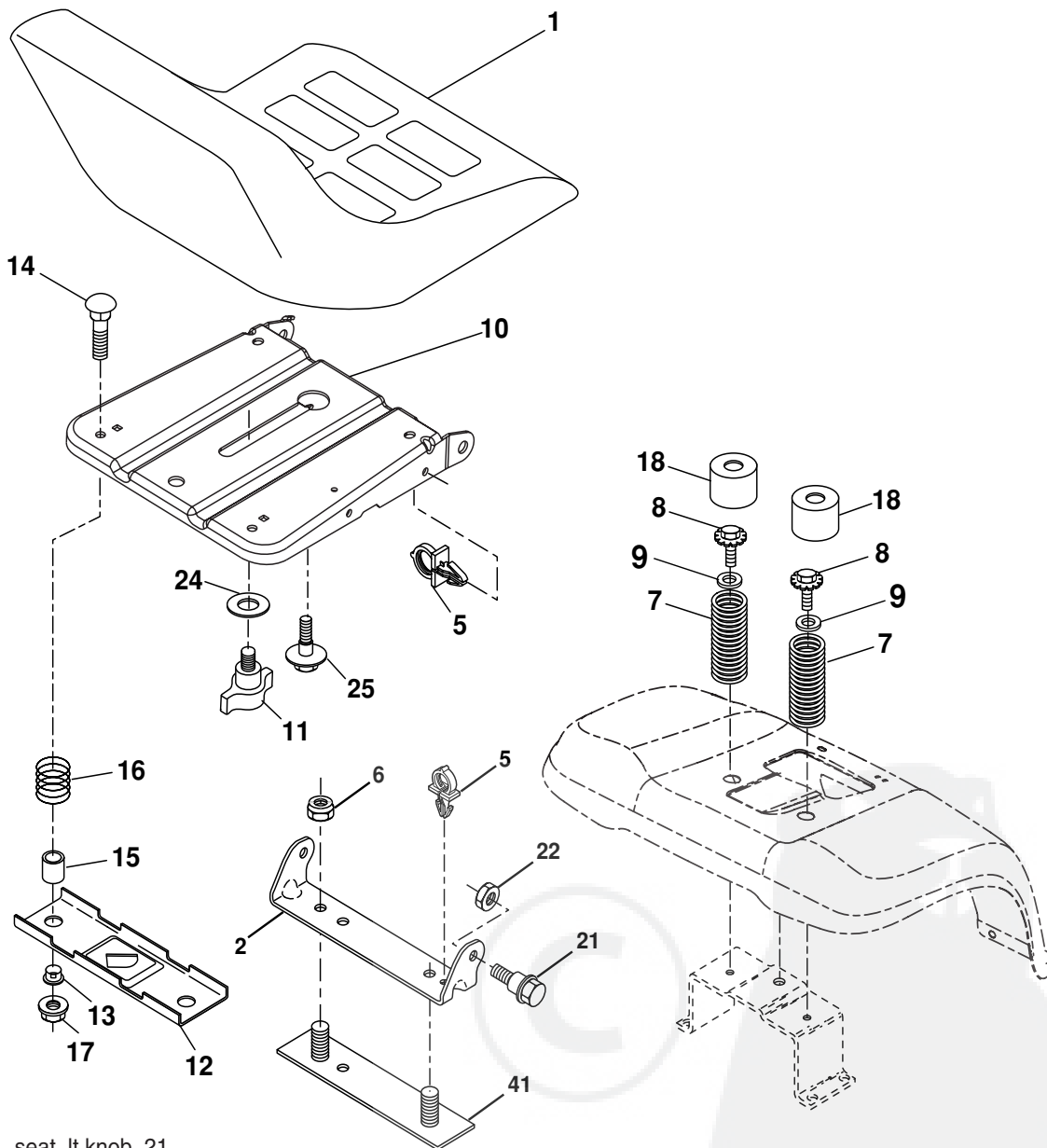

seat_lt.knob_21

KEY NO.	PART NO.	DESCRIPTION
1	188714	Seat
2	140551	Bracket Pnt Pivot Seat (blk)
5	145006	Clip Push In Hinged
6	STD541437	Nut Hex Lock w/Ins 3/8-16 unc
7	124181X	Spring Seat Cprsn 2 250 Blk Zi
8	17000616	Screw 3/8-16 x 1
9	19131614	Washer 13/32 x 1 x 14 Ga.
10	195530	Pan Pnt Seat (blk)
11	166369	Knob Seat Adj Wingnut
12	174648	Bracket Pnt Mounting Switch
13	121248X	Bushing Snap Blk Nyl 50 ld
14	72050412	Bolt Rdhd Sht Nk 1/4-20 x 1-1/2

KEY NO.	PART NO.	DESCRIPTION
15	121249X	Spacer Split
16	123740	Spring Cprsn
17	123976X	Nut Lock 1/4 Lge Flg Gr. 5 Zinc
18	124238X	Cap Spring
21	171852	Bolt Shoulder 5/16-18 unc-2A
22	STD541431	Nut Hex Lock w/Ins 5/16-18
24	19171912	Washer 17/32 x 1-3/16 x 12 Ga.
25	127018X	Bolt Shoulder 5/16-18 x .62
41	140675	Strap Asm Fender

NOTE: All component dimensions given in U.S. inches
1 inch = 25.4 mm

REPAIR PARTS

TRACTOR- -MODEL NO. 917. 274261

DECALS

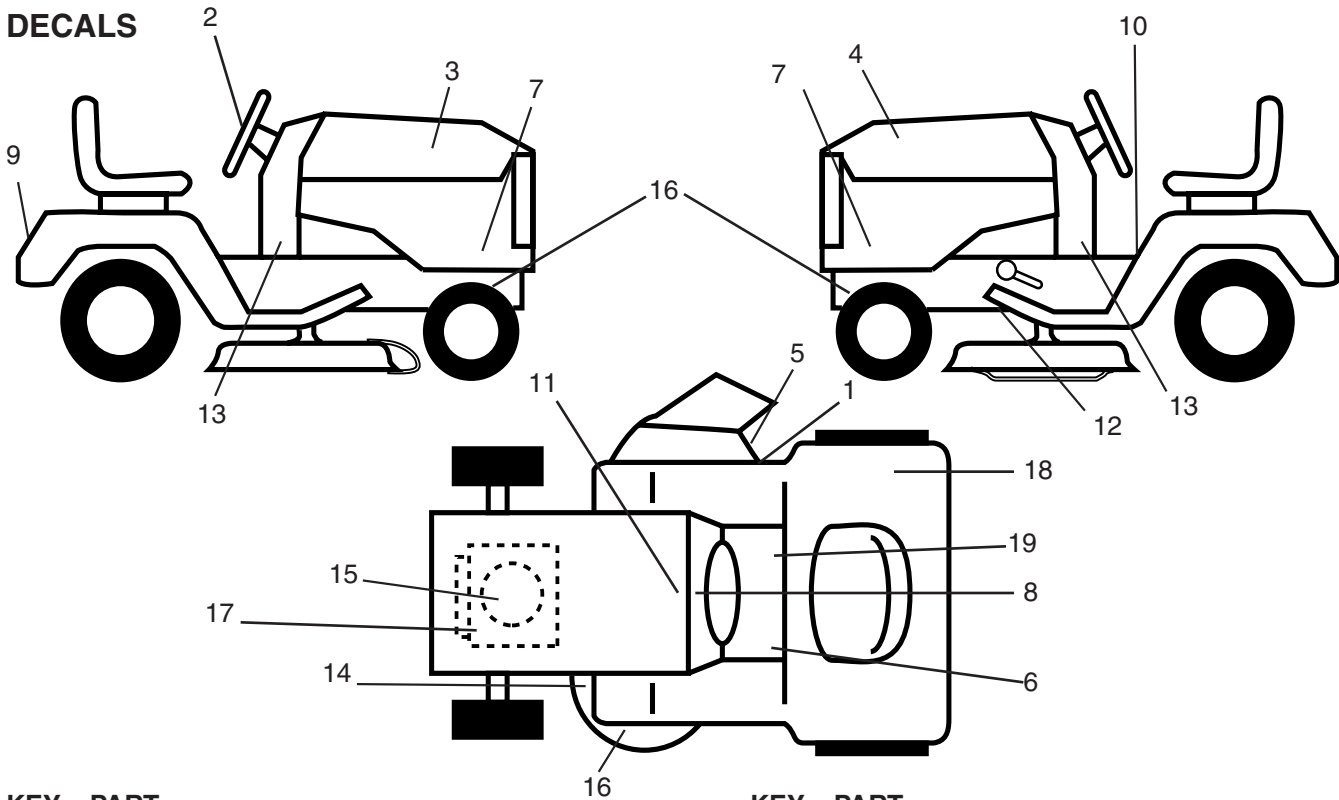

KEY NO.	PART NO.	DESCRIPTION
1	196357	Decal, Warning
2	164065	Decal, Steering Wheel
3	194023	Decal, Hood, R.H.
4	194024	Decal, Hood, L.H.
5	182166	Decal, Cut Finger
6	159737	Decal, Brake Clutch
7	404777	Decal, Hood Side
8	196347	Decal, Dash
9	403259	Decal, Fender, Craftsman
10	400389	Decal, Fender Danger
11	145005	Decal, Battery Dngr/Psn Eng
12	197490	Decal, V-Belt Drive Schematic
13	405422	Decal, Dash Panel
14	160396	Decal, V-Belt Schematic
15	196841	Decal, Engine Warn/Sym

KEY NO.	PART NO.	DESCRIPTION
16	159736	Decal, Hot Muffler
17	404807	Decal, Engine HP
18	180432	Decal, Fender DB/CE
19	140837	Decal, Parking Brake
--	138311	Decal, Lift Handle
--	162598	Decal Load Limit
--	178392	Decal, Chassis Disconnect
--	184310X428	Pad, Footrest LH STLT
--	184311X428	Pad, Footrest RH STLT
--	405411	Manual, Operator's Euro
--	405412	Manual, Operator's Scan
--	405413	Manual, Operator's Ebloc
--	405414	Manual, Operator's Baltic
--	405378	Manual, Parts

WHEELS & TIRES

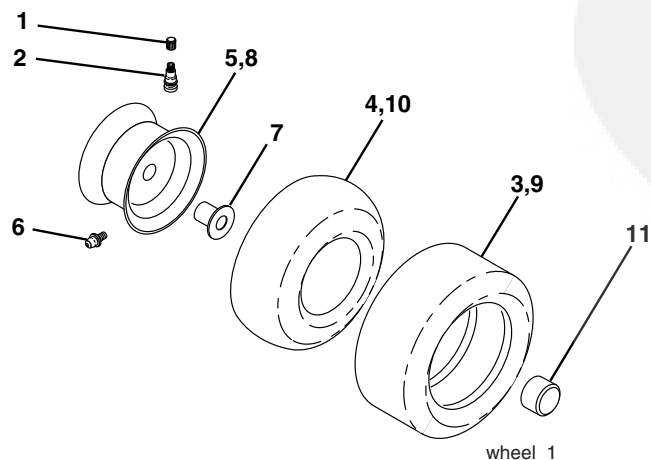

KEY NO.	PART NO.	DESCRIPTION
1	59192	Cap Valve Tire
2	65139	Stem Value
3	106222X	Tire F Ts 15 x 6.0 - 6 Service
4	59904	Tube Inner Front #35060
5	106732X643	Rim Asm 6" front Service
6	278H	Fitting Grease
7	9040H	Bearing Flange
8	106108X643	Rim Asm 8" rear Service
9	122082X	Tire R Ts 20 x 10-8 Service
10	7152J	Tube Rear 9.5 x 8 Service
11	104757X643	Cap Axle Blk 1.50 x 1.00
--	144334	Sealant, Tire (10 oz. tube)

NOTE: All component dimensions given in U.S. inches
1 inch = 25.4 mm

REPAIR PARTS

TRACTOR- -MODEL NO. 917. 274261

MOWER LIFT

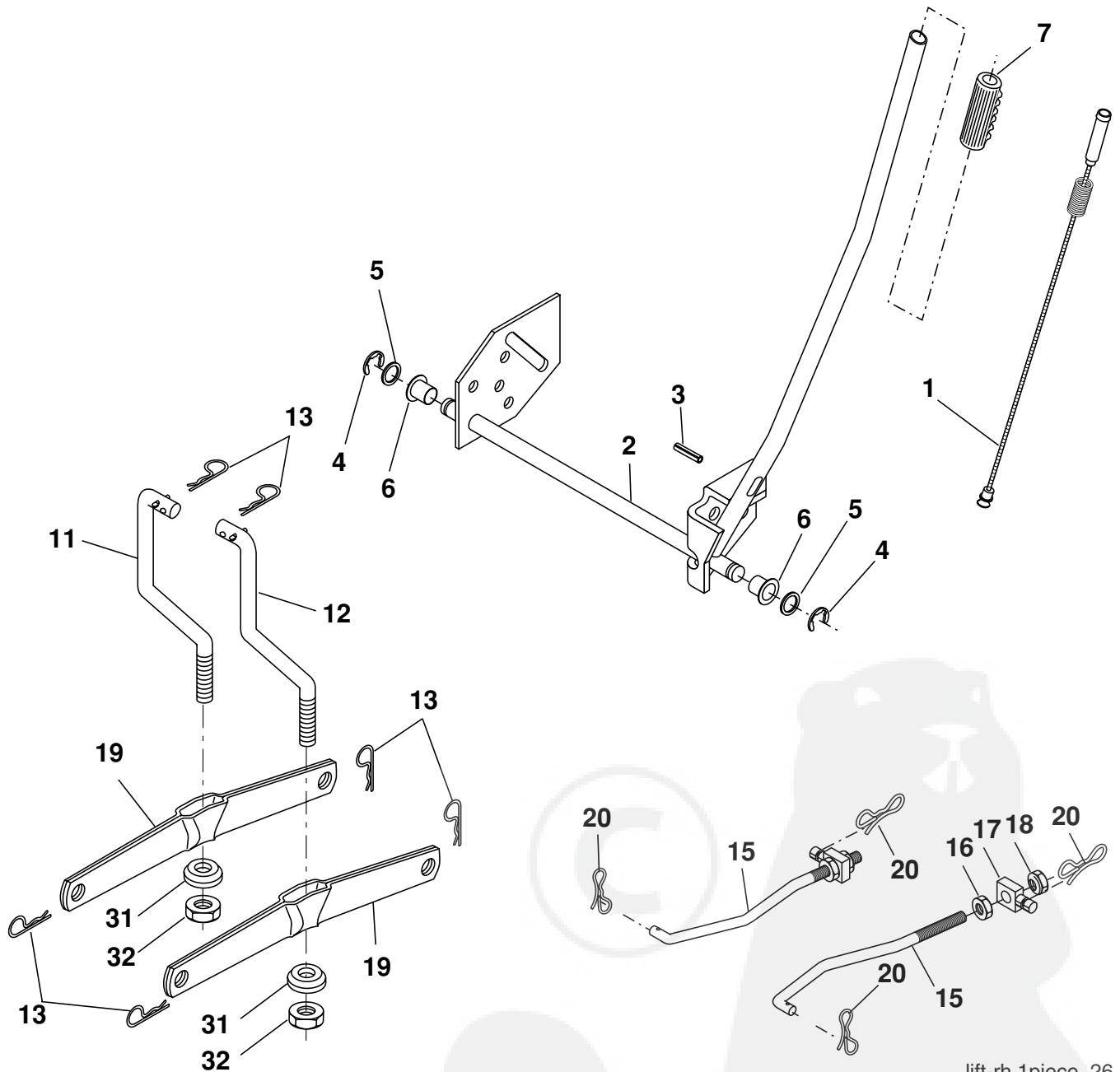

lift-rh.1piece_26

KEY NO.	PART NO.	DESCRIPTION
1	197980	Plunger Asm.
2	198070	Shaft Asm. Lift
3	188822	Pin Groove
4	12000002	E Ring #5133-62
5	19211621	Washer 21/32 x 1 x 21 Ga.
6	120183X	Bearing Nylon
7	175830	Grip Handle
11	139865	Link Asm Lift L.H.
12	139866	Link Asm Lift R.H.
13	STD624008	Retainer Spring

KEY NO.	PART NO.	DESCRIPTION
15	173288	Link Front
16	73350800	Nut Jam Hex 1/2-13 unc
17	175689	Trunnion Blk Zinc
18	73800800	Nut Lock w/Wsh 1/2-13 unc
19	139868	Arm Suspension Mower
20	194209	Pin Cotter 7/16 Bow Tie Lock
31	169865	Bearing, Pvt. Lift
32	73540600	Nut Crownlock 3/8-24

NOTE: All component dimensions given in U.S. inches
1 inch = 25.4 mm

REPAIR PARTS

TRACTOR- -MODEL NO. 917. 274261

MOWER

KEY NO.	PART NO.	DESCRIPTION	KEY NO.	PART NO.	DESCRIPTION
1	182032	Mower Deck Assembly, 42"	68	180215	V-Belt
2	STD533107	Bolt	92	73800600	Nut Lock 3/8-16 unc
3	138017	Bracket Assembly, Sway Bar, Front	101	193107	Mulching Cover
4	165460	Bracket Sway Bar 38/42" Deck	102	71081010	Screw Phillips 10-24 x 5/8
5	STD624008	Retainer Spring	103	19061216	Washer #10
6	178024	Bar Sway Deck	104	10071000	Washer Lock #10
8	850857	Bolt, Hex 3/8-24 x 1.25 Gr. 8	105	160793	Latch Asm.
9	STD551137	Washer, Lock	106	2029J	Nut Weld
10	140296	Washer, Hardened	113	17000510	Bolt 5/16-18
		(The following baldes are available)	116	4898H	Bolt Shoulder
11	134149	Blade, 42" Mulching Std	117	188606	Wheel Guage
		(For mulching mowers only)	118	73930600	Nut Lock 3/8-16 unc
13	137645	Shaft Assembly, Mandrel, Vented	119	19121414	Washer 3/8 x 7/8 x 14
14	128774	Housing, Mandrel, Vented	129	19131312	Washer 13/32 x 13/16 x 12Ga.
15	110485X	Bearing, Ball, Mandrel	130	74780616	Bolt Fin Hex 3/8-16 uncx 1 Gr.5
16	174493	Stripper, Vented Mower Deck	131	72140608	Bolt 3/8-16 unc x 1
18	72140505	Bolt, Carriage 5/16-18 x 5/8	134	156941	Pin Head Rivet
19	132827	Bolt, Shoulder	135	159765	Bracket Asm Wheel Ga Rear LH
20	159770	Baffle, Vortex	136	155986	Bar Adjusting Guage Wheel
21	STD541431	Nut Crownlock 5/16-18 unc	138	159763	Bracket Asm Wheel Ga Rear RH
23	177563	Bracket, Deflector	139	159767	Bracket Asm Wheel Ga Front RH
24	105304X	Cap, Sleeve	140	159768	Bracket Asm Wheel Ga Front LH
25	123713X	Spring, Torsion, Deflector	142	165890	Arm Spring Brake Mower
26	110452X	Nut, Push	143	157109	Bracket Arm Idler 42"
27	130968X428	Shield, Deflector	144	158634	Keeper Belt 42" Clutch Cable
28	19111016	Washer 11/32 x 5/8 x 16 Ga.	145	165888	Pulley Idler Flat
29	131491	Rod, Hinge	146	171977	Bolt Carriage Idler
30	173984	Screw Thdrol Washer Head	147	179748	Spring Extension
31	187690	Washer, Spacer	148	169022	Spring Return Idler
32	153535	Pulley, Mandrel	149	165898	Retainer Spring Yellow Zinc
33	178342	Nut, Toplock, Flanged	150	19091210	Washer 9/32 x 3/4 x 10 Ga.
34	72110612	Bolt Carr. Sh. 3/8-16 x 1-1/2 Gr. 5	152	181555	Cable Clutch 42 In
36	131494	Pulley, Idler, Flat	159	72140614	Bolt Rdhd Sqn 3/8-16 unc x 3/4
40	73900600	Nut Lock 3/8-16 unc	183	194208	Pin Cotter 5/16 Bowtie Lock
44	140088	Guard, Mandrel, L.H.	184	19131410	Washer 13/13 x7/8 x 10 Ga.
45	STD624003	Retainer	185	188234	Head Asm Cable Clutch
46	137729	Screw, Thd. Roll 1/4-20 x 5/8	--	130794	Mandrel Assembly (Includes
48	133944	Washer, Hardened			Housing, Shaft and Shaft
52	139888	Bolt, Shoulder 5/16-18 unc			Hardware Only - Pulley Not
53	184907	Arm Assembly, Pad, Brake			Included)
54	178515	Washer, Hardened	--	187694	Replacement Mower, Complete
55	155046	Arm, Idler			
56	165723	Spacer, Retainer			
59	141043	Guard, TUV Idler			

NOTE: All component dimensions given in U.S. inches
1 inch = 25.4 mm

REPAIR PARTS

TRACTOR- -MODEL NO. 917. 274261

PEERLESS TRANSAXLE - MODEL NUMBER LTH2000

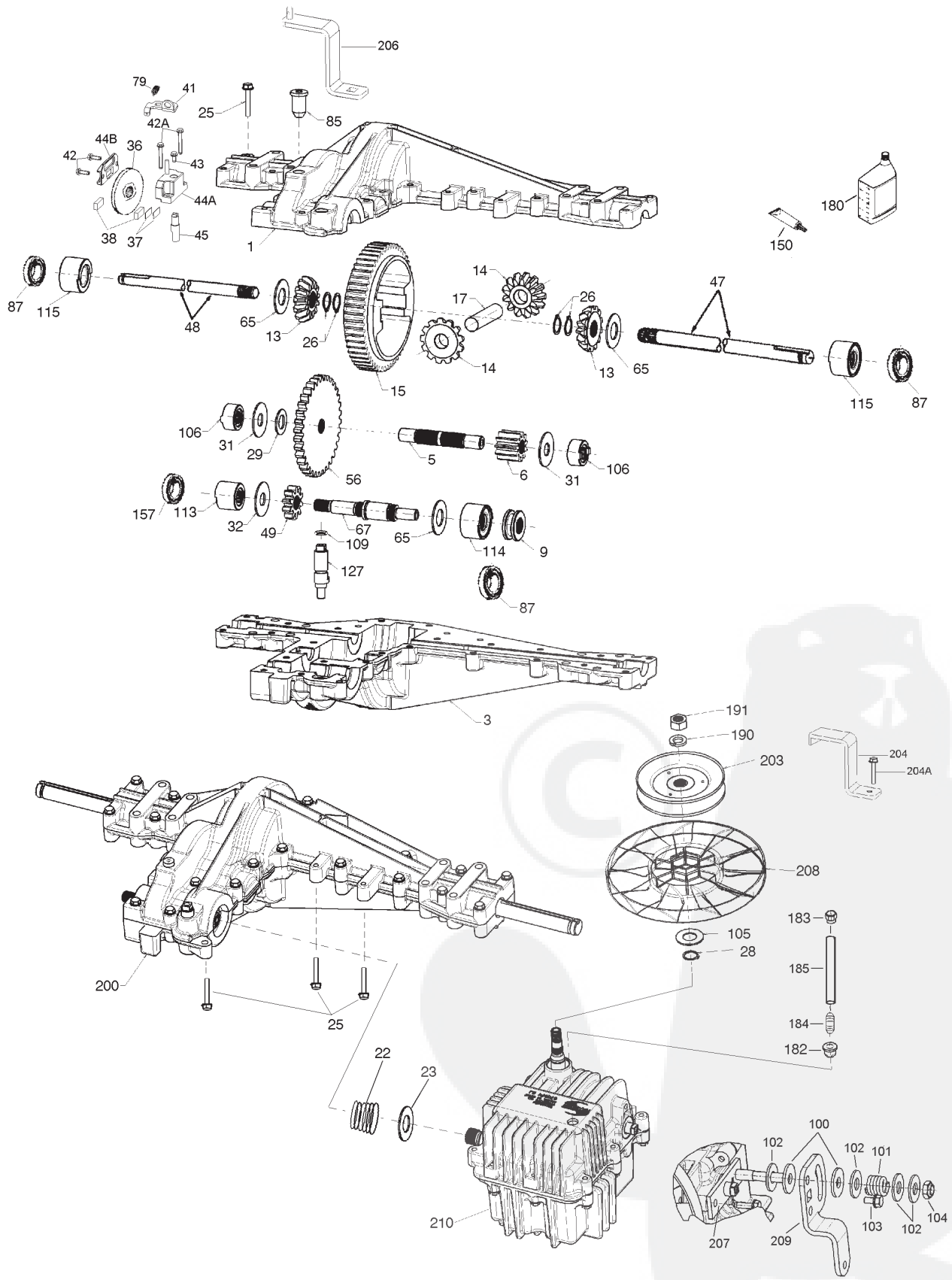

REPAIR PARTS

TRACTOR- -MODEL NO. 917. 274261

PEERLESS TRANSAXLE - MODEL NUMBER LTH2000

KEY NO.	PART NO.	DESCRIPTION	KEY NO.	PART NO.	DESCRIPTION
1	772151	Cover L.H.	70	786196	Spacer .625 .765
3	770135	Case	79	792201	Spring
5	776355	Counter Shaft	85	792154	Oil Fill Plug
6	778263	Spur Gear 11T	87	788088A	Oil Seal 3/4"
9	786197	Neutral Sleeve (.572)	99	792141	Washer .377ID .058W
13	778368	Bevel Gear (Incl. 14) (13 Teeth)	100	792200	Snubber Washer
14	778368	Bevel Gear (Incl. 13) (13 Teeth)	101	792199	Snubber Spring .47ID
15	778373	Ring Gear (54 Teeth)	102	792184	Washer .437ID .078W
17	786139	Drive Pin	103	792193	Screw, 1/4-28 x .490
22	792194	Spring	104	792198	Nut, 3/8-24
23	792195	Washer .750 ID	105	780096	Washer .625 ID .057W
25	792073A	Screw 1/4-20 x 1-1/4"	106	786162	Sleeve Assembly
26	792125	Retaining Ring	107	792046	Screw, 1/4-20 x 1"
28	792035	Retaining Ring	109	788104	"O" Ring
29	780065	Washer .627 ID .091W	113	786199	Sleeve Ass'y (Incl. 157)
31	780189	Washer .563 ID .062W	114	786200	Sleeve Ass'y (Incl. 87)
36	790071	Brake Disk	115	786198	Sleeve Assembly (Incl. 87)
37	790007	Brake Pad Plate	127	784384	Shift Lever Ass'y (Incl. 109)
38	799021	Brake Pad	150	788093A	Liquid Gasket RTV Silicon
40	792204	Roll Pin .25	157	788102	Oil Seal 9/16"ID
41	790102	Brake Lever	180	730229	BOil Spec. (80W90)
42	792202	Screw, 1/4-20 x 3/4	182	788103	Grommet
42A	792203	Screw, 1/4-20 x 1-3/4	183	792118	Relief Valve
43	792171	Screw, 10-24 x .500	184	792196	Hose Barb
44A	790100	Inside Brake (Mach)	185	798050	Tubing 1/2 x 5
44B	790099	Outside Brake (Casting)	190	792150	Washer
45	790101	Actuator Rod	191	792151	Nut 7/16-20
47	774869	Axle 16.812	200	794787	Differential (Gear Reduction Drive)
48	774688	Axle 11.625	203	798044	Pulley & Hub Ass'y
49	778378	Spur Gear 18T	206	798055	Disconnect Lever
56	778379	Spur Gear 81T	207	798053	Mounting Plate
65	780195	Washer .750ID .062W	208	798040	Fan
67	776440	Brakeshaft	209	798054	Control Lever
			210	794788	Hydro Module LH Fender Control

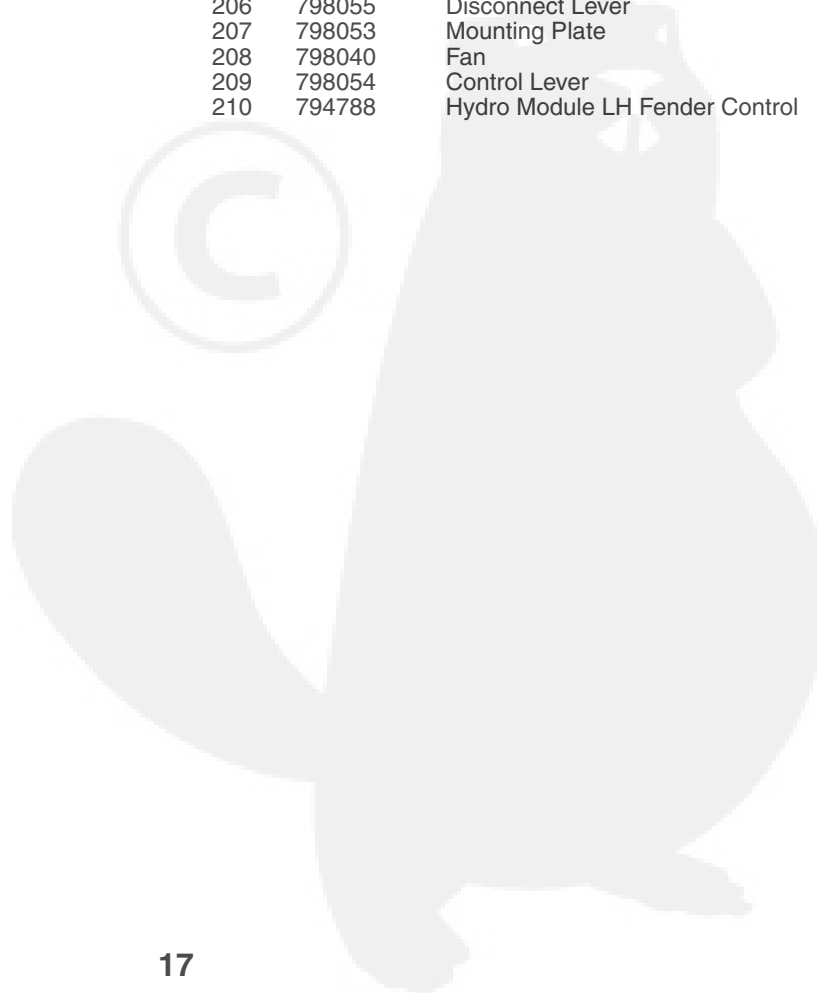

REPAIR PARTS

TRACTOR- -MODEL NO. 917. 274261

BRIGGS & STRATTON ENGINE - - MODEL NUMBER 441777, TYPE NUMBER 0651-B1

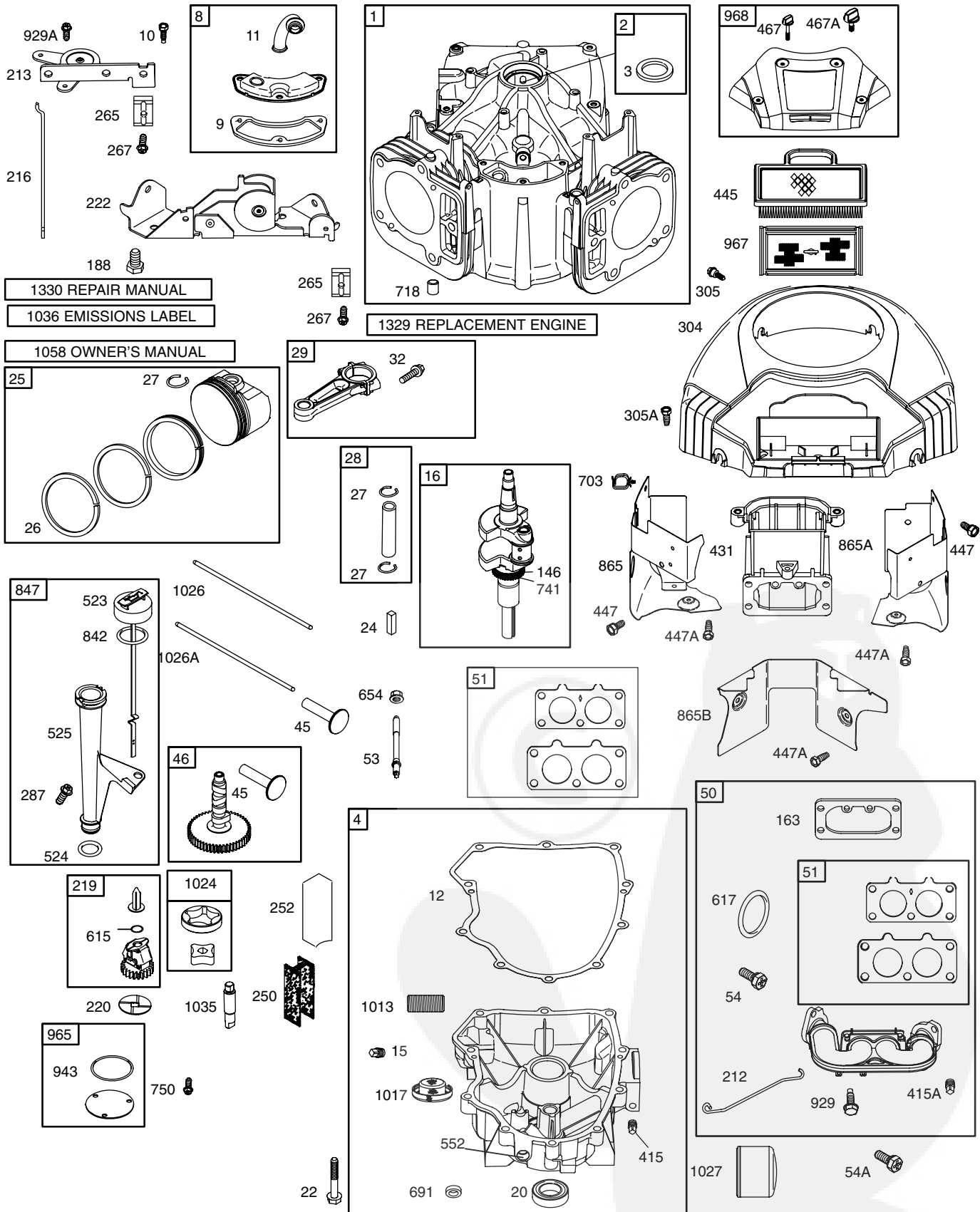

REPAIR PARTS

TRACTOR- -MODEL NO. 917. 274261

BRIGGS & STRATTON ENGINE - - MODEL NUMBER 441777, TYPE NUMBER 0651-B1

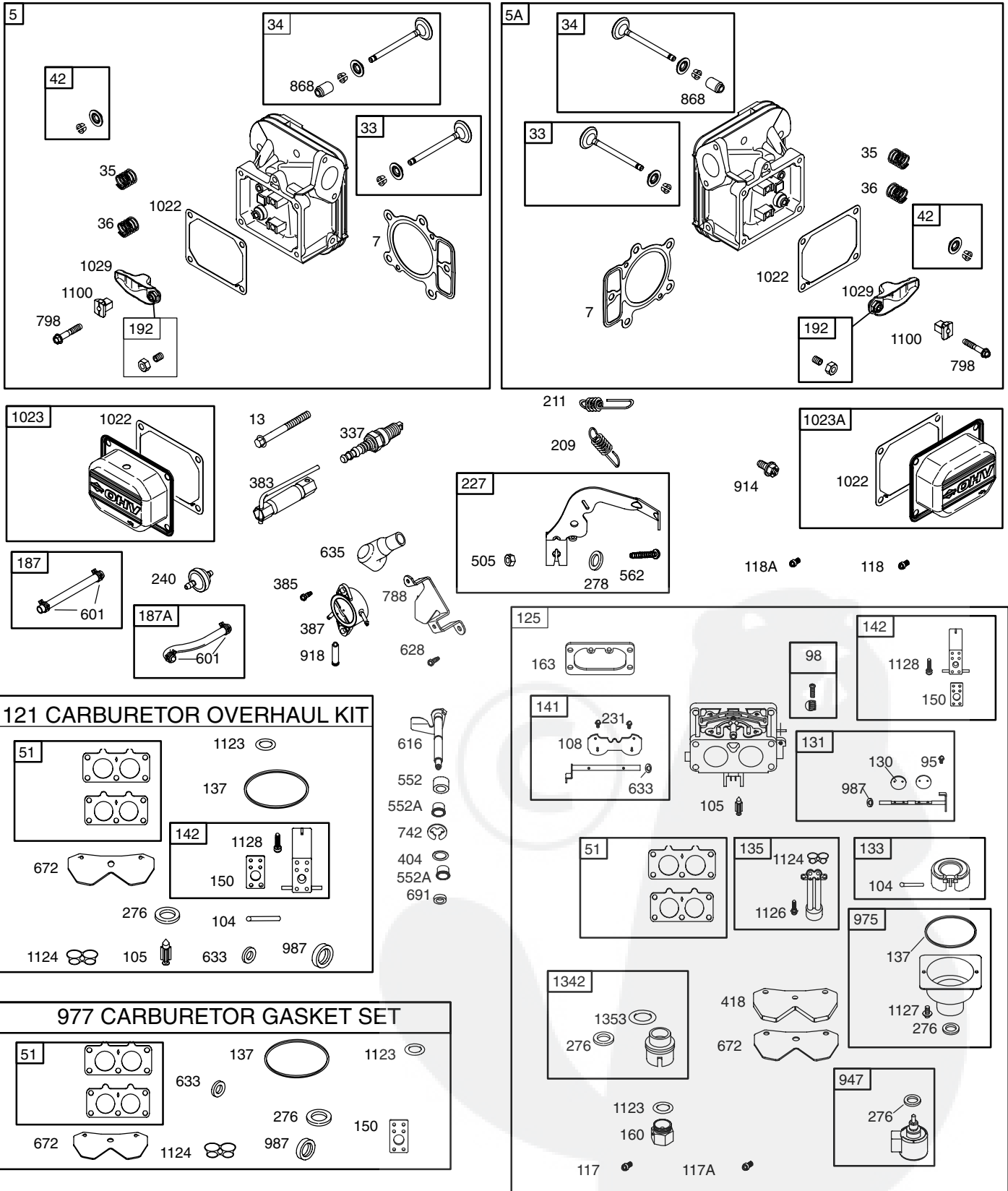

REPAIR PARTS

TRACTOR- -MODEL NO. 917. 274261

BRIGGS & STRATTON ENGINE - - MODEL NUMBER 441777, TYPE NUMBER 0651-B1

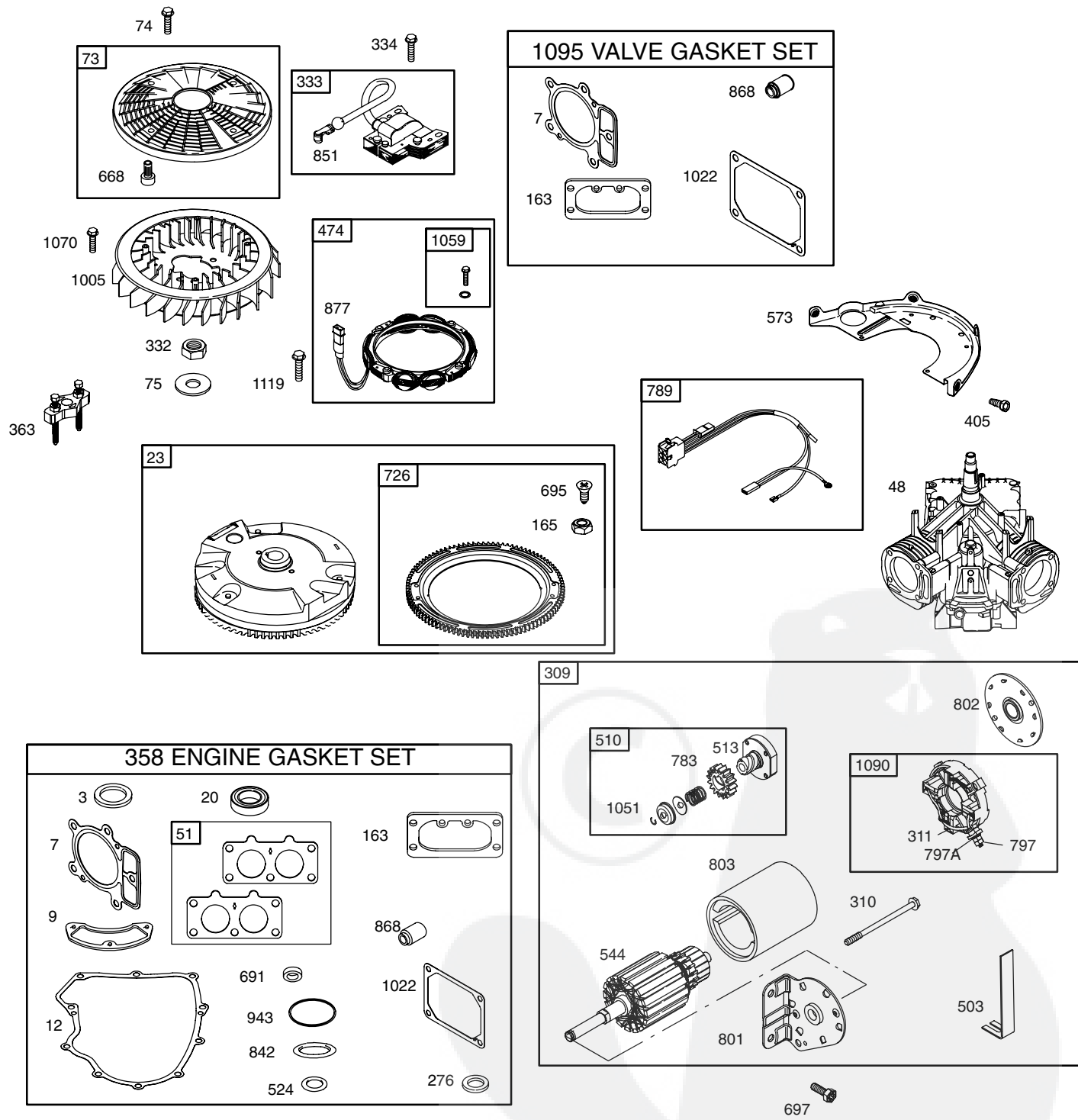

REPAIR PARTS

TRACTOR- -MODEL NO. 917. 274261

BRIGGS & STRATTON ENGINE - - MODEL NUMBER 441777, TYPE NUMBER 0651-B1

KEY NO.	PART NO.	DESCRIPTION	KEY NO.	PART NO.	DESCRIPTION
1	699753	Cylinder Assembly	130	690993	Valve-Throttle
2	499585	Kit-Bushing/Seal (Magneto Side)	131	499805	Kit-Throttle Shaft
3	391086s	• Seal-Oil (Magneto Side)	133	699724	Float-Carburetor
4	699747	Sump-Engine	135	699729	Tube-Fuel Transfer
5	693998	Head-Cylinder (Cylinder 1)	137	690994	Ø Gasket-Float Bowl
5A	693999	Head-Cylinder (Cylinder 2)	141	699722	Kit-Choke Shaft
7	693997	•+ Gasket-Cylinder Head	142	699726	Nozzle-Carburetor
8	792185	Breather Assembly	146	690979	Key-Timing
9	690937	• Gasket-Breather	150	690995	Gasket-Nozzle
10	691108	Screw (Breather Assembly)	160	699727	Retainer-Solenoid
11	792184	Tube-Breather	163	691001	Gasket-Air Cleaner
12	697227	• Gasket-Crankcase	165	693148	Nut (Ring Gear)
13	791130	Screw (Cylinder Head)	187	791766	Line-Fuel (Cut to Required Length)
15	690946	Plug-Oil Drain	187A	791801	Line-Fuel (Molded)
16	699700	Crankshaft	188	691108	Screw (Control Bracket)
20	690947	• Seal-Oil (PTO Side)	192	690083	Adjuster-Rocker Arm
22	694966	Screw (Engine Sump)	209	697674	Spring-Governor
23	691054	Flywheel	211	691019	Spring-Governed Idle
24	222698s	Key-Flywheel	212	695238	Link-Throttle
25	792117	Piston Assembly (Standard)	213	691021	Bracket-Choke Control
25	792144	Piston Assembly (.020" Oversize)	216	691022	Link-Choke
26	792026	Ring Set-Piston (Standard)	219	698231	Gear-Governor
26	792073	Ring Set-Piston (.020" Oversize)	220	690412	Washer (Governor Lever)
27	690975	Lock-Piston Pin	222	698757	Bracket-Control
28	690229	Pin-Piston	227	792492	Lever-Governor Control
29	699699	Rod-Connecting	231	690718	Screw (Choke Valve)
32	690976	Screw (Connecting Rod)	240	691035	Filter-Fuel
33	499596	Valve-Exhaust	250	690957	Retainer-Breather
34	697464	Valve-Intake	252	690956	Collector-Oil
35	690963	Spring-Valve (Intake)	265	691024	Clamp-Casing
36	690963	Spring-Valve (Exhaust)	267	695134	Screw (Casing Clamp)
42	499586	Keeper-Valve	276	690997	Ø+ Washer-Sealing
45	690977	Tappet-Valve	287	691108	Screw (Dipstick Tube)
46	790562	Camshaft	304	790688	Housing-Blower
48	698172	Short Block	305	691005	Screw (Blower Housing)
50	695241	Manifold-Intake	305A	790690	Screw (Blower Housing)
51	791677	• Ø‡ Gasket-Intake	309	497595	Motor-Starter
53	690951	Stud (Carburetor)	310	690323	Bolt-Starter Motor
54	699816	Screw (Intake Manifold)	311	497608	Brush Set
54A	695239	Screw (Intake Manifold)	332	691059	Nut (Flywheel)
73	499439	Screen-Rotating	333	691060	Armature-Magneto
74	698425	Screw (Rotating Screen)	334	691061	Screw (Magneto Armature)
75	691056	Washer (Flywheel)	337	691043	Plug-Spark
95	690718	Screw (Throttle Valve)			
98	699721	Kit-Idle Speed			
104	694918	Ø Pin-Float Hinge			
105	698537	Ø Valve-Float Needle			
108	699723	Valve-Choke			
117	699732	Jet-Main (Standard)			
117A	699733	Jet-Main (Standard)			
118	699733	Jet-Main (High Altitude)(Left)			
118A	699458	Jet-Main (High Altitude (Right)			
121	699734	Kit-Carburetor Overhaul			
125	699709	Carburetor			
127	698810	Plug-Welch			

- Included in Engine Gasket Set, Key. No. 358
- Ø Included in Carburetor Overhaul Kit, Key. No. 121
- ‡ Included in Carburetor Gasket Set, Key. No. 977
- + Included in Valve Gasket Set, Key. No. 1095

NOTE: All component dimensions given in U.S. inches 1 inch = 25.4 mm

REPAIR PARTS

TRACTOR- -MODEL NO. 917. 274261

BRIGGS & STRATTON ENGINE - - MODEL NUMBER 441777, TYPE NUMBER 0651-B1

KEY NO.	PART NO.	DESCRIPTION	KEY NO.	PART NO.	DESCRIPTION
358	694012	Set-Engine Gasket	842	691031	• Seal-Dipstick/Tube
363	19203	Flywheel Puller	847	499602	Dipstick/Tube Assembly
383	19374	Wrench-Spark Plug	851	493880s	Terminal-Spark Plug
385	691108	Screw (Fuel Pump)	865	691012	Cover-Air Guide
387	808656	Pump-Fuel	865A	691014	Cover-Air Guide
404	690442	Washer (Governor Crank)	865B	691015	Cover-Air Guide
405	697820	Screw (Back Plate)	868	690968	•+ Seal-Valve
415	690283	Plug (Crankcase Cover/Sump)	877	393456	Wire/Connector-Alternator
415A	690283	Plug (Intake Manifold)	914	691127	Screw (Rocker Cover)
418	690999	Plate-Carburetor	918	694000	Hose-Vacuum
431	790816	Elbow-Intake	929	691003	Screw (Choke Control Bracket)
445	499486s	Filter-Air Cleaner Cartridge	943	690589	• Seal-O Ring (Oil Pump Cover)
447	691003	Screw (Air Guide Cover)	947	699728	Solenoid-Fuel
447A	691108	Screw (Air Guide Cover)	965	499613	Cover-Oil Pump
467	691008	Knob-Air Cleaner	967	273638s	Filter-Pre Cleaner
467	790697	Knob-Air Cleaner	968	790689	Cover-Air Cleaner
474	696459	Alternator	975	499810	Bowl-Float
503	691532	Strap-Ground	977	699735	Gasket Set-Carburetor
505	691029	Nut (Governor Control Lever)	987	691000	Ø Seal-Throttle Shaft
510	696541	Drive-Starter	1005	790698	Fan-Flywheel
513	692024	Clutch-Drive	1013	690954	Nipple-Oil Filter
523	691036	Dipstick	1017	690770	Screen-Oil Pump
524	691032	• Seal-Dipstick Tube	1022	690971	•+ Gasket-Rocker Cover
525	691037	Tube-Dipstick	1023	499599	Cover-Rocker (Cylinder 1)
544	692034	Armature-Starter	1023A	499600	Cover-Rocker (Cylinder 2)
552	690552	Bushing-Governor Crank	1024	499054	Pump-Oil
552A	690553	Bushing-Governor Crank	1026	690981	Rod-Push (Steel)
562	690311	Bolt (Governor Control Lever)	1026A	690982	Rod-Push (Aluminum)
573	790444	Plate-Back	1027	492932s	Filter-Oil
601	691038	Clamp-Hose	1029	690972	Arm-Rocker
615	698290	Retainer-Governor Shaft	1035	691042	Shaft-Pump
616	691045	Crank-Governor	1036	792019	Label-Emissions
617	697891	Seal-O Ring (Intake Manifold)	1051	691265	Ring-Retaining
628	691108	Screw (Fuel Pump Bracket)	1058	276245	Owner's Manual
633	690998	Ø Seal-Choke/Throttle Shaft	1059	698516	Kit-Screw/Washer
635	66538s	Boot-Spark Plug	1070	690372	Screw (Flywheel Fan)
654	690958	Nut (Carburetor)	1090	691293	Retainer-Brush
668	691215	Spacer	1095	699735	Kit-Valve Overhaul
672	690234	Gasket-Carburetor Plate	1100	791959	Pivot-Rocker Arm
691	790574	• Seal-Governor Shaft	1119	691183	Screw (Alternator)
695	693149	Screw (Ring Gear)	1123	699725	Seal-O Ring (Solenoid Retainer)
697	690372	Screw (Drive Cap)	1124	690988	Seal-O Ring (Fuel Transfer Tube)
703	691010	Clip	1126	690991	Screw (Fuel Transfer Tube)
718	690959	Pin-Locating	1127	690992	Screw (Float Bowl)
726	499612	Gear-Ring	1128	690990	Screw (Carburetor Nozzle)
741	690980	Gear-Timing	1329	441777-0025	Replacement Engine (Transfer the speed limiter control assembly to the replacement engine. Transfer the governor spring to the replacement engine).
742	690328	Retainer-E Ring			Repair Manual
750	696999	Screw (Oil Pump Cover)	1330	273521	Extension-Fuel Transfer Tube
783	695708	Gear-Pinion	1342	699731	
788	691039	Bracket-Fuel Pump			
789	698330	Harness-Wiring			
797	691029	Nut (Brush Retainer)			
797A	693167	Nut (Brush Retainer)			
798	697890	Screw (Rocker Arm)			
801	691283	Cap-Drive			
802	691286	Cap-End			
803	-- -- ----	Housing-Starter (Service with complete Starter Motor 497595)			

NOTE: All component dimensions given in U.S. inches 1 inch = 25.4 mm

LIMITED WARRANTY ON CRAFTSMAN TRACTOR AND BATTERY

2-YEAR ON TRACTOR

When used and maintained according to the operator's manual instructions, if this tractor fails due to a defect in material or workmanship within two years from the date of purchase, call 1-800-4-MY-HOME® to arrange for free repair.

During the first 30 days of purchase, there will be no charge to service the product in your home. For your convenience, in-home warranty service will still be available after the first 30 days of purchase, but a trip charge will apply. This charge will be waived if you transport the product to an authorized Craftsman drop-off location. For the nearest authorized location, call 1-800-4-MY-HOME®.

Tractor warranty coverage does not include:

- Expendable items which become worn during normal use, including but not limited to blades, spark plugs, air cleaners, belts, and oil filters.
- Standard maintenance servicing, oil changes, or tune-ups.
- Tire replacement or repair caused by punctures from outside objects, such as nails, thorns, stumps, or glass.
- Repairs necessary because of operator abuse, including but not limited to damage caused by towing objects beyond the capability of the tractor, impacting objects that bend the frame or crankshaft, or over-speeding the engine.
- Repairs necessary because of operator negligence, including but not limited to electrical and mechanical damage caused by improper storage, failure to use the proper grade and amount of engine oil, failure to keep the deck clear of flammable debris, or failure to maintain the equipment according to the instructions contained in the operator's manual.
- Engine (fuel system) cleaning or repairs necessary because of fuel determined to be contaminated or oxidized (stale). In general, fuel should be used within 30 days of its purchase date.
- Normal deterioration and wear of the exterior finishes, or product label replacement.
- The tractor battery, which is covered for only 90 days as stated below.

90-DAYS ON BATTERY

For ninety (90) days from the date of purchase, if the battery included with this tractor is defective in material or workmanship (our testing proves it will not hold a charge), it will be replaced free of charge.

During the first 30 days of purchase, there will be no charges to replace the battery in your home. For your convenience, in-home warranty service will still be available after the first 30 days of purchase, but a trip charge will apply. This charge will be waived if you transport the battery to an authorized Craftsman drop-off location. For the nearest authorized location, call 1-800-4-MY-HOME®.

All tractor and battery warranty coverage is void if this product is used for commercial or rental purposes.

This warranty applies only while this product is within the United States.

This warranty gives you specific legal rights, and you may also have other rights, which vary, from state to state.

Sears, Roebuck and Co., Dept. 817WA, Hoffman Estates, IL 60179

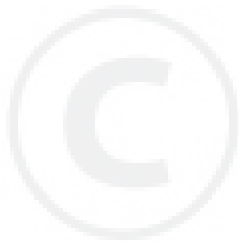

CRAFTSMAN®