

ILLUSTRATED PARTS LIST

MODEL NO. 96061021500

CUSTOMER CATALOG NO. GARDOL 185107HRB

PRODUCT NO. 960 61 02-15



**TRACTOR -- MODEL NO. GARDOL 185107HRB (96061021500), PRODUCT NO. 960 61 02-15
DECALS 27**

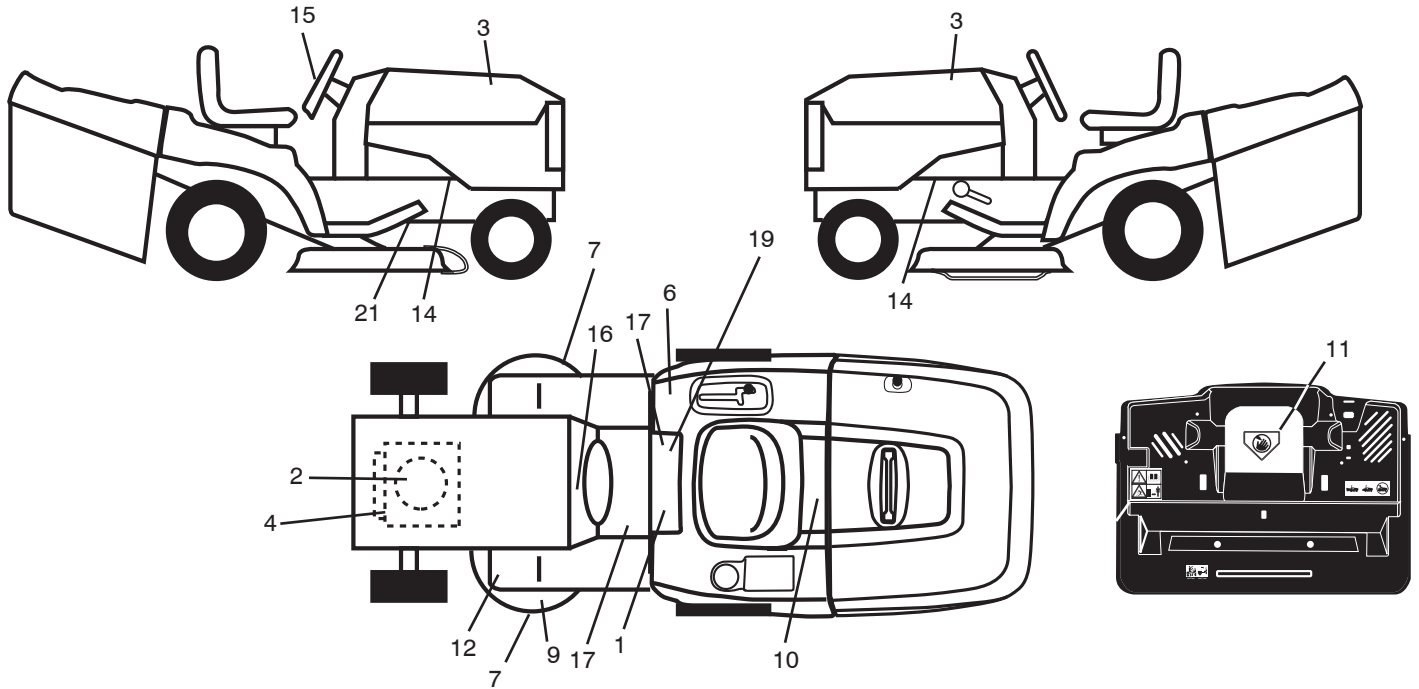

KEY NO.	PART NO.	DESCRIPTION
1	532 40 03-89	Decal, Warning Syms. CE
2	532 40 88-20	Decal, Hp Engine
3	532 41 06-99	Decal, Hood
4	532 19 68-41	Decal, Warning Eng. Syms.
6	532 18 04-32	Decal, 100 DBA/CE
7	532 19 68-42	Decal, SDL SHF/CRD Sym. Cutfinger
9	532 18 78-11	Decal, Mower Enviro
10	532 14 50-05	Decal, Bat Dan/Poi P/L Sym Wpn
11	532 18 21-66	Decal, Mower Cut Finger CE
12	532 15 97-37	Decal, Brake/Clutch Symbol Lt
14	532 15 97-36	Decal, Chassis Hot Muffler

KEY NO.	PART NO.	DESCRIPTION
15	532 41 07-04	Decal, Steering Wheel
16	532 19 46-06	Decal, Dash
17	532 14 08-37	Decal, Saddle Brake Parking
21	532 16 62-86	Decal, Hex Belt Sch 92 CRD
--	532 13 83-11	Decal, Lift Handle
--	532 16 69-60	Decal Bypass
--	532 18 10-91	Pad Footrest LH
--	532 18 10-90	Pad Footrest RH
--	532 40 09-09	Manual Operator's (Euro)
--	532 40 09-10	Manual Operator's (Scan)
--	532 41 19-56	Manual Operator's (E-Bloc)
--	532 41 19-57	Manual Operator's (Baltic)

WHEELS & TIRES

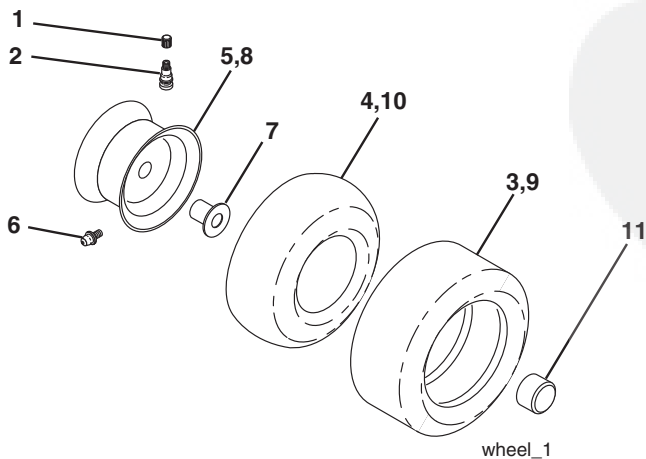

KEY NO.	PART NO.	DESCRIPTION
1	532 05 91-92	Cap Valve Tire
2	532 06 51-39	Stem Valve
3	532 10 62-22	Tire F Ts 15 x 6 0 - 6 Service
4	532 05 99-04	Tube Inner Front #35060
5	532 13 83-36	Rim Asm 6" Front Service
6	532 12 49-57	Fitting Grease
7	532 12 49-59	Bearing Flange
8	532 13 83-37	Rim Asm 8" Rear Service
9	532 13 84-68	Tire R Ts 20 x 8-8 C.Service
10	532 12 49-26	Tube Rear 9 5 x 8 Service
11	532 17 50-39	Cap Axle Blk 1 50 x 1 00
--	532 14 43-34	Sealant, Tire (10 oz. tube)

NOTE: All component dimensions given in U.S. inches
1 inch = 25.4 mm

TRACTOR -- MODEL NO. GARDOL 185107HRB (96061021500), PRODUCT NO. 9606102-15
SCHEMATIC 38

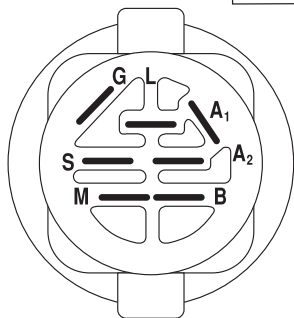
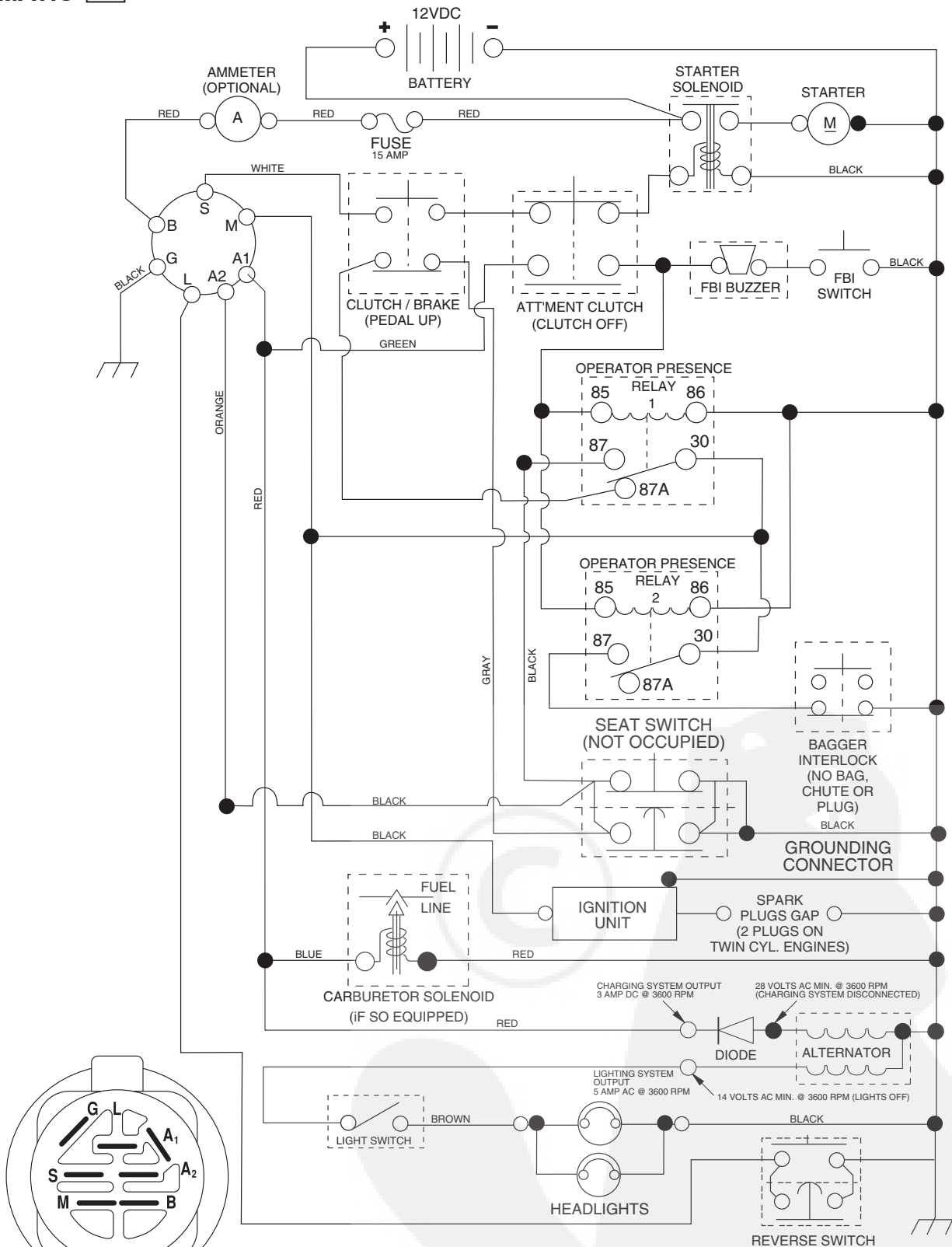

IGNITION SWITCH

POSITION	CIRCUIT	"MAKE"
OFF	M+G+A1	
RUN/OVERRIDE	B+A1	
RUN	B+A1	L+A2
START	B + S + A1	

WIRING INSULATED CLIPS
NOTE: IF WIRING INSULATED CLIPS WERE REMOVED FOR SERVICING OF UNIT, THEY SHOULD BE REPLACED TO PROPERLY SECURE YOUR WIRING.



03055

TRACTOR -- MODEL NO. GARDOL 185107HRB (96061021500), PRODUCT NO. 960 61 02-15
ELECTRICAL **32**

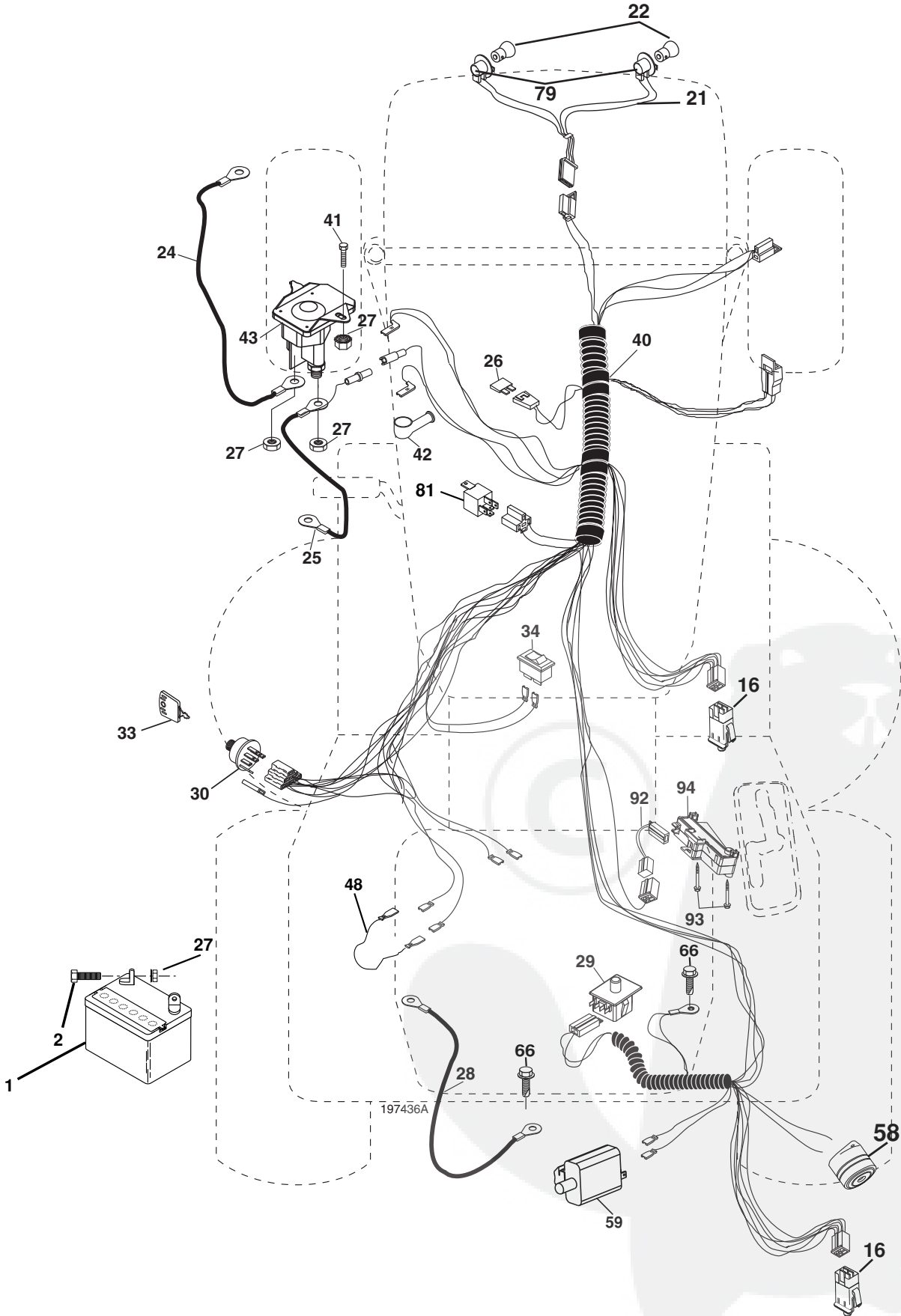

**TRACTOR--MODEL NO. GARDOL 185107HRB (96061021500), PRODUCT NO. 96061 02-15
ELECTRICAL 32**

KEY NO.	PART NO.	DESCRIPTION
1	532 16 34-65	Battery
2	874 76 04-12	Bolt Hex Hd 1/4-20 unc x 3/4
16	532 17 61-38	Switch Interlock Push-In
21	532 17 56-88	Harness Asm. Light
22	532 00 41-52	Bulb Light #1156
24	532 12 47-80	Cable Starter 6 Ga. 11" Red
25	532 16 59-87	Cable Battery Crd 56" Red
26	532 17 51-58	Fuse 20 Amp
27	873 51 04-00	Nut Keps Hex 1/4-20 unc
28	532 12 77-25	Cable Ground 6 Ga. 18" Black
29	532 19 27-49	Switch Seat
30	532 19 33-50	Switch Ignition
33	532 14 04-01	Key Ign
34	532 11 07-12	Switch Light/Reset
40	532 19 74-36	Harness Ign
41	871 11 04-08	Bolt Flk Fin Hex 1/4-20 unc x 1/2
42	532 13 15-63	Cover Terminal Red
43	532 19 25-07	Solenoid
48	532 14 08-44	Adapter Ammeter Rectangular
58	532 16 94-19	Buzzer Crd
59	532 18 03-79	Switch FBI CRD
66	817 49 06-08	Screw Thdrol 3/8-16 x 1/2 Ty-Tt
79	532 17 52-42	Socket Asm. Bulb
81	532 10 97-48	Relay Asm
92	532 19 66-15	Harness Pigtail
93	532 19 25-40	Screw Plastite 10-14 x 2.0
94	532 19 18-34	Module Reverse ROS

NOTE: All component dimensions given in U.S. inches.
1 inch = 25.4 mm.

**TRACTOR--MODEL NO. GARDOL 185107HRB (96061021500), PRODUCT NO. 96061 02-15
CHASSIS AND ENCLOSURES 39**

KEY NO.	PART NO.	DESCRIPTION	KEY NO.	PART NO.	DESCRIPTION
1	532 17 46-20	Chassis	161	532 16 46-55	Bumper Hood
2	532 18 03-84	Drawbar	162	532 18 03-82	Bracket Exten Chassis Lh CRD
3	817 06 06-12	Screw 3/8-16 x 3/4	163	532 18 03-83	Bracket Exten Chassis Rh CRD
6	532 18 44-19	Saddle	164	532 16 56-05	Support Battery CRD
8	532 12 64-71	Clip Insulator 13/32 Mtg. Hole	165	532 18 13-56	Cover Battery
9	532 19 56-46	Dash	170	532 19 94-88	Backplate CRD
10	872 14 06-08	Bolt, Carriage 3/8-16 x 3/4	171	872 14 06-20	Bolt Rdhd Sqnk 3/8-16 x 2-1/2 Gr. 5
11	532 16 72-03	Panel, Dash, L.H.	172	819 13 20-16	Washer 13/32 x 1-1/4 x 16 Ga.
13	532 19 49-76	Panel, Asm. Dash R.H.	173	873 51 06-00	Nut, Keps Hex 3/8-16 unc
15	874 18 05-12	Screw Mach. trhd. 5/16-18 UNC x 3/4	175	532 18 82-03	Guard Trap
16	873 51 05-00	Nut Keps 5/16-18 UNC	179	532 18 82-02	Rod Pivot FBI CRD
17	532 19 56-47	Hood	184	532 17 46-62	Bracket Actuator Bagger CRD
24	874 78 06-16	Bolt	185	532 18 11-01	Knob Rod Brake Parking
25	819 13 13-12	Washer 13/32 x 13/16 x 12 Ga.	186	532 16 07-93	Latch Asm Mulch/Bagger
26	873 80 06-00	Nut	187	532 12 50-04	Nut Weld
28	532 18 71-14	Grille	188	819 06 12-16	Washer #10
29	532 17 97-63	Light Asm.	189	810 07 10-00	Washer Lock #10
30	532 19 73-64	Fender	190	871 08 10-10	Screw Pan Hd Phillip 10-24 x 5/8
31	532 16 51-56	Bracket, Fender Support	198	532 16 89-37	Nut, Push
33	532 18 25-07	Footrest, L.H.	205	817 49 06-08	Screw Thdrol 3/8-16 x 1/2
34	532 18 25-08	Footrest, R.H.	207	817 67 05-08	Screw Thdrol 5/16-18 x 1/2
35	872 11 06-06	Bolt	209	817 00 06-12	Screw Hex Wsh Thdrol 3/8-16
37	817 49 05-08	Screw Thdrol 5/16-18 x 1/2 TYT	213	532 18 71-12	Skirt Grille LH
38	532 18 17-48	Bracket Asm Pivot Mower Rear	214	532 18 71-11	Skirt Grille RH
54	532 19 25-12	Screw 10-32 x 5/8	256	532 18 13-61	Cover Fender Rack
58	532 17 53-51	Duct Air	258	532 16 18-42	Lens Grille RH
64	532 19 93-95	Bracket Dash Lower	259	532 16 18-41	Lens Grille LH
67	532 10 69-32	Knob	265	532 18 57-04	Seal Side RH Bagger
69	532 14 24-32	Screw Hx Wsh Hi-Lo 1/4-1/2	266	532 18 57-03	Seal Side LH Bagger
89	532 19 73-66	Console Crd Auto	278	532 19 16-11	Screw 10 x 3/4 Single Lead Hex
145	532 15 65-24	Rod Pivot Chassis/Hood			
154	532 19 48-28	Clutch Asm Brkt.			
155	532 18 39-26	Bracket Dash LH			

NOTE: All component dimensions given in U.S. inches.
1 inch = 25.4 mm.

TRACTOR -- MODEL NO. GARDOL 185107HRB (96061021500), PRODUCT NO. 9606102-15
DRIVE **40**

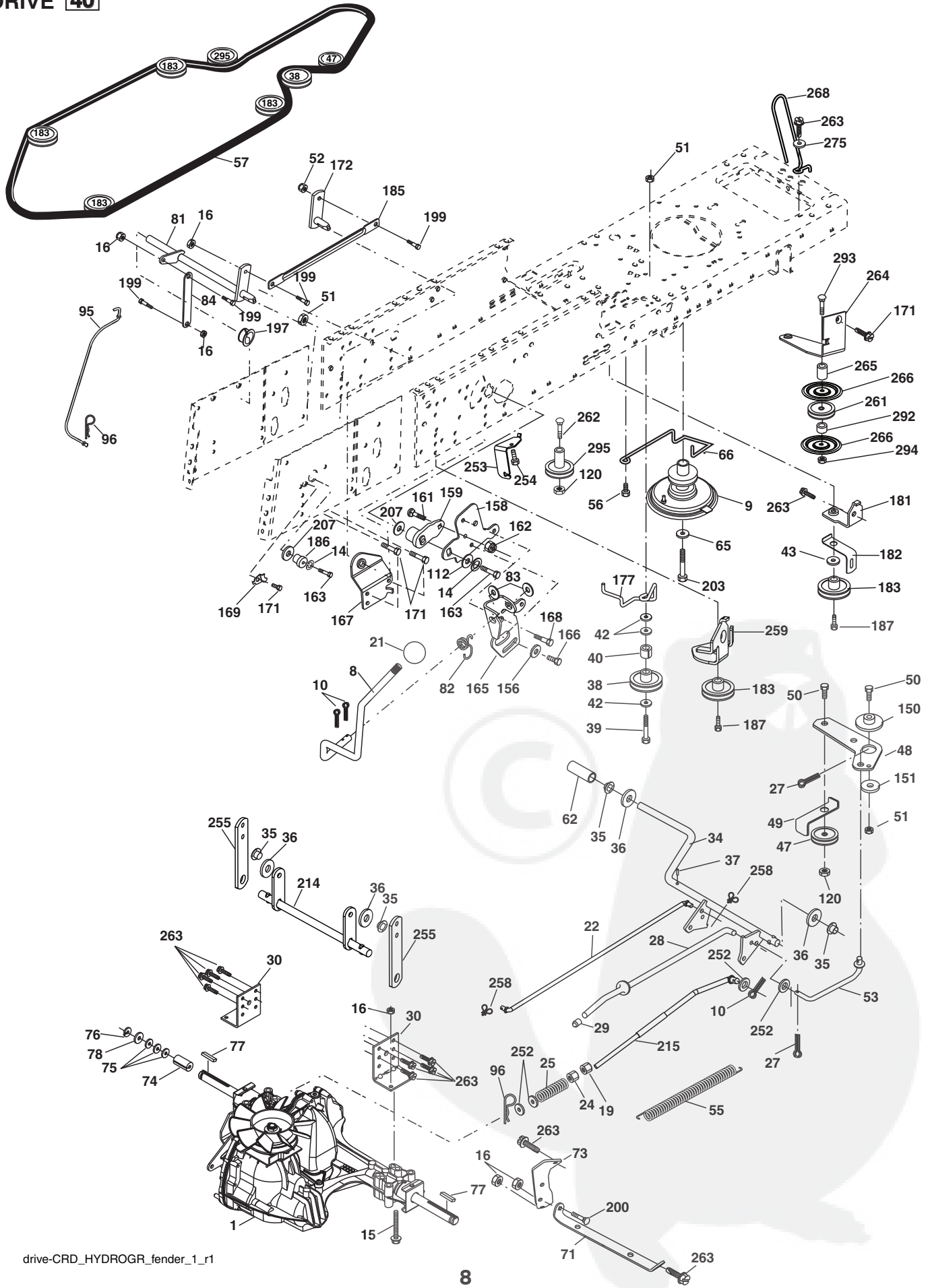

**TRACTOR--MODEL NO. GARDOL 185107HRB (96061021500), PRODUCT NO. 96061 02-15
DRIVE **40****

KEY NO.	PART NO.	DESCRIPTION	KEY NO.	PART NO.	DESCRIPTION
1	-----	Transaxle Hydro Gear 321-0510	150	532 16 58-50	Bushing, Bellcrank Grnd Dr
8	532 19 27-06	Rod, Shift Fender Adjust Lt	151	819 13 32-10	Washer 13/32 x 2 x 10 Ga.
9	532 40 85-79	Clutch Asm Noram	156	532 16 60-02	Washer Srrted 5/16 ID x 1.125
10	876 02 04-16	Pin, Cotter 1/8 x 1	158	532 16 55-89	Bracket Shift Mount
14	810 04 04-00	Washer, Lock Hvy Helical	159	532 18 39-00	Hub Shift
15	874 49 05-44	Bolt Hex FGHD 5/16-18 x Gr 5	161	872 14 04-06	Bolt Rdhd Sqnk 1/4-20 x 3/4 Gr 5
16	873 80 05-00	Nut Lock Hex W/Ins 5/16-18 unc	162	873 68 04-00	Nut Crownlock 1/4-20 unc
19	873 80 06-00	Nut Lock Hex w/Ins 3/8-16 unc	163	874 78 04-16	Bolt Hex Fin 1/4-20 unc x 1 Gr 5
21	532 14 08-45	Knob	165	532 16 56-23	Bracket Pivot Lever
22	532 17 56-07	Rod Brake Main	166	817 49 05-10	Screw 5/16-18 x 5/8
24	873 35 06-00	Nut Hex Jam 3/8-16 unc	167	532 16 55-88	Bracket Support Shift CRD
25	532 19 20-36	Spring, Rod, Brake	168	532 16 54-92	Bolt Shoulder 5/16-18 x .561
27	876 02 04-12	Pin, Cotter 1/8 x 3/4	169	532 16 55-80	Plate Fastening Lt
28	532 17 57-65	Rod, Parking Brake	171	817 49 06-08	Screw Thdrol 3/8-16 x 1/2 Ty-Tt
29	532 07 16-73	Cap, Parking Brake	172	532 17 02-71	Shaft Asm Shifter Frt CRD
30	532 16 95-92	Bracket, Mfg. Transaxle	177	532 16 59-32	Keeper Flat Idler 3.06" CRD
34	532 17 55-78	Shaft, Asm Pedal Foot CRD	181	532 18 02-11	Bracket Idler Ground Drive CRD
35	532 12 01-83	Bearing, Nylon	182	532 18 26-82	Keeper Belt 2.5" Od V-Idler CRD
36	819 21 16-16	Washer 21/32 x 1 x 16 Ga.	183	532 19 95-32	Pulley V-Idler CRD
37	532 12 49-63	Pin, Roll 3/16 x 1"	185	532 17 00-08	Link Shift
38	532 16 59-36	Pulley Flat Composite 3.06"	186	532 16 56-14	Hub Tapered Round CRD
39	874 76 06-44	Bolt Fin Hex 3/8-16 unc x 2-3/4	187	817 58 05-20	Screw Thdrol 5/16-18 x 1.25
40	532 12 49-65	Spacer, Split 395 x 59 Bzp	197	532 16 96-13	Nyliner Snap-In 5/8
42	819 13 13-12	Washer 13/32 x 13/16 x 12 Ga.	199	532 16 96-12	Bolt Shoulder 5/16-18 unc
43	819 11 10-12	Washer 11/32 x 5/8 x 12 Ga.	200	872 14 05-08	Bolt RDHD SQNK 5/16-18 x 1
47	532 12 77-83	Pulley, Idler, V Groove Plasitc	203	871 17 07-80	Bolt Hex 7/16-20 x 5
48	532 15 44-07	Bellcrank Clutch Grnd Drv	207	532 16 98-45	Washer Nylon Rear
49	532 12 32-05	Retainer, Belt Style Spring	214	532 17 56-09	Shaft Asm. Brake
50	872 11 06-12	Bolt Carr. Sh. 3/8-16 x 1-1/2 Gr. 5	215	532 17 56-52	Rod Brake Hydro
51	873 68 06-00	Nut, Crownlock 3/8-16 unc	252	819 13 16-16	Washer 13/32 x 1 x 16 Ga.
52	873 68 05-00	Nut Crownlock 5/16-18	253	532 17 50-28	Bracket Cable Chassis
53	532 19 96-52	Link, Clutch 7.66	254	817 00 06-16	Screw 3/8-16 x 1
55	532 10 57-09	Spring, Return, Clutch	255	532 17 56-08	Brace Shaft Brake Mtg.
56	817 06 06-20	Screw 3/8-16 x 1-1/4	258	532 17 80-62	Clip Retainer
57	532 17 01-40	V-Belt Kev 112" 0650 CRD	259	532 18 02-12	Bracket Pulley
62	532 12 48-72	Cover, Pedal	261	532 13 14-94	Pulley Idler
65	810 04 07-00	Washer	262	872 11 06-22	Bolt Carr. 3/8-16 x 2-3/4 Gr.5
66	532 15 47-78	Keeper, Belt Engine F-Proof	263	817 00 06-12	Screw 3/8-16 x 3/4
71	532 16 91-83	Strap, Torque, Lh	264	532 19 76-08	Bracket Idler Chassis
73	532 16 91-82	Strap, Torque, Rh	265	532 40 46-07	Spacer Idler Chassis
74	532 13 70-57	Spacer, Split	266	532 18 20-61	Shield Idler Mower
75	532 12 17-49	Washer 25/32 x 1-1/4 x 16 Ga.	268	532 18 24-02	Guard Muffler RH
76	812 00 00-01	Ring, E	275	819 13 16-14	Washer 13/32 x 1 x 14 Ga.
77	532 12 35-83	Key, Square	292	532 40 02-71	Spacer Noram
78	532 12 17-48	Washer 25/32 x 1-5/8 x 16 Ga.	293	872 14 06-28	Bolt 3/8-16 x 3-1/2
81	532 17 00-06	Asm, Shaft,Cross Rear	294	532 19 70-33	Nut 3/8-16
82	532 16 57-11	Spring, Torsion	295	532 17 91-14	Pulley Idler Composite
83	819 17 12-16	Washer 17/32 x 3/4 x 16 Ga.			
84	532 17 00-07	Link, Transaxle			
95	532 17 00-15	Control Asm Bypass Hydro			
96	532 12 47-88	Spring, Retainer 1"			
112	819 09 12-10	Washer 9/32 x 3/4 x 10 Ga.			
120	873 90 06-00	Nut Lock Flg. 3/8-16 unc			

NOTE: All component dimensions given in U.S. inches
1 inch = 25.4 mm

TRACTOR -- MODEL NO. GARDOL 185107HRB (96061021500), PRODUCT NO. 960 61 02-15
STEERING ASSEMBLY **41**

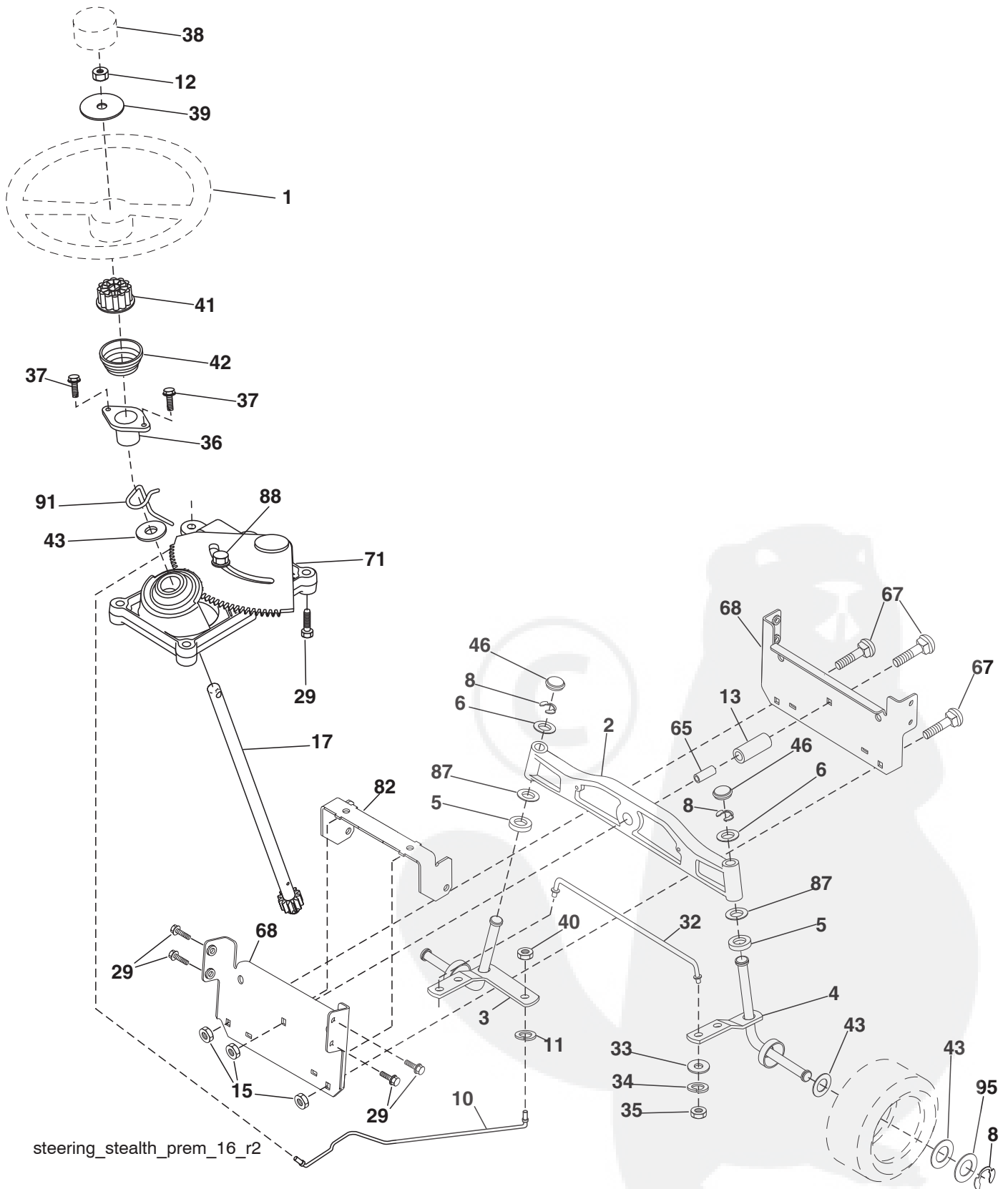

**TRACTOR--MODEL NO. GARDOL 185107HRB (96061021500), PRODUCT NO. 96061 02-15
STEERING ASSEMBLY **41****

KEY NO.	PART NO.	DESCRIPTION
1	532 19 39-43	Steering Wheel
2	532 18 47-06	Cast Iron Axle Assembly
3	532 16 98-40	Spindle Assembly, L.H.
4	532 16 98-39	Spindle Assembly, R.H.
5	532 12 49-31	Bearing, Race, Thrust, Hardened
6	532 12 17-48	Washer 25/32 x 1-5/8 x 16 Ga.
8	812 00 00-29	Ring, Klip
10	532 17 51-21	Link, Drag
11	810 04 06-00	Washer, Lock
12	873 94 08-00	Nut Hex Jam Toplock 1/2-20 unf
13	532 13 65-18	Spacer Brg Axle Front
15	532 14 52-12	Nut, Hexflange Lock
17	532 17 78-83	Shaft Assembly, Steering
29	817 00 06-12	Screw, 3/8-16 x 3/4
32	532 17 01-62	Rod, Tie
33	819 11 12-16	Washer 11/32 x 3/4 x 16 Ga.
34	810 04 05-00	Washer Lock Hvy Hlcl Spr 5/16
35	873 54 05-00	Nut Crownlock 5/16-24 unf
36	532 15 51-05	Bushing, Steering
37	532 15 29-27	Screw TT #10-32 x 5 x 3/8 Flange
38	532 19 46-03	Cap Wheel Steer
39	819 18 38-12	Washer 9/16 x 2-3/8 12 Ga.
40	873 54 06-00	Nut Crownlock 3/8-24
41	532 18 67-37	Adaptor, Steering Wheel
42	532 17 71-49	Boot, Steering
43	532 12 17-49	Washer 25/32 x 1-1/4 x 16 Ga.
46	532 12 12-32	Cap, Spindle
65	532 16 03-67	Spacer Brace Axle
67	872 11 06-18	Bolt Rdhd Sq 3/8-16 unc x 2-1/4
71	532 17 51-46	Steering Asm.
68	532 16 98-27	Brace Axle
82	532 19 99-78	Bracket Susp Chassis Front
87	532 17 39-66	Washer Flat .781 x 1-1/2 x .14
88	532 17 51-18	Bolt Shoulder 7/16-20 unc
91	532 17 55-53	Clip Steering
95	532 18 89-67	Washer Harden .793 x 1.637 x 060

NOTE: All component dimensions given in U.S. inches.
1 inch = 25.4 mm.

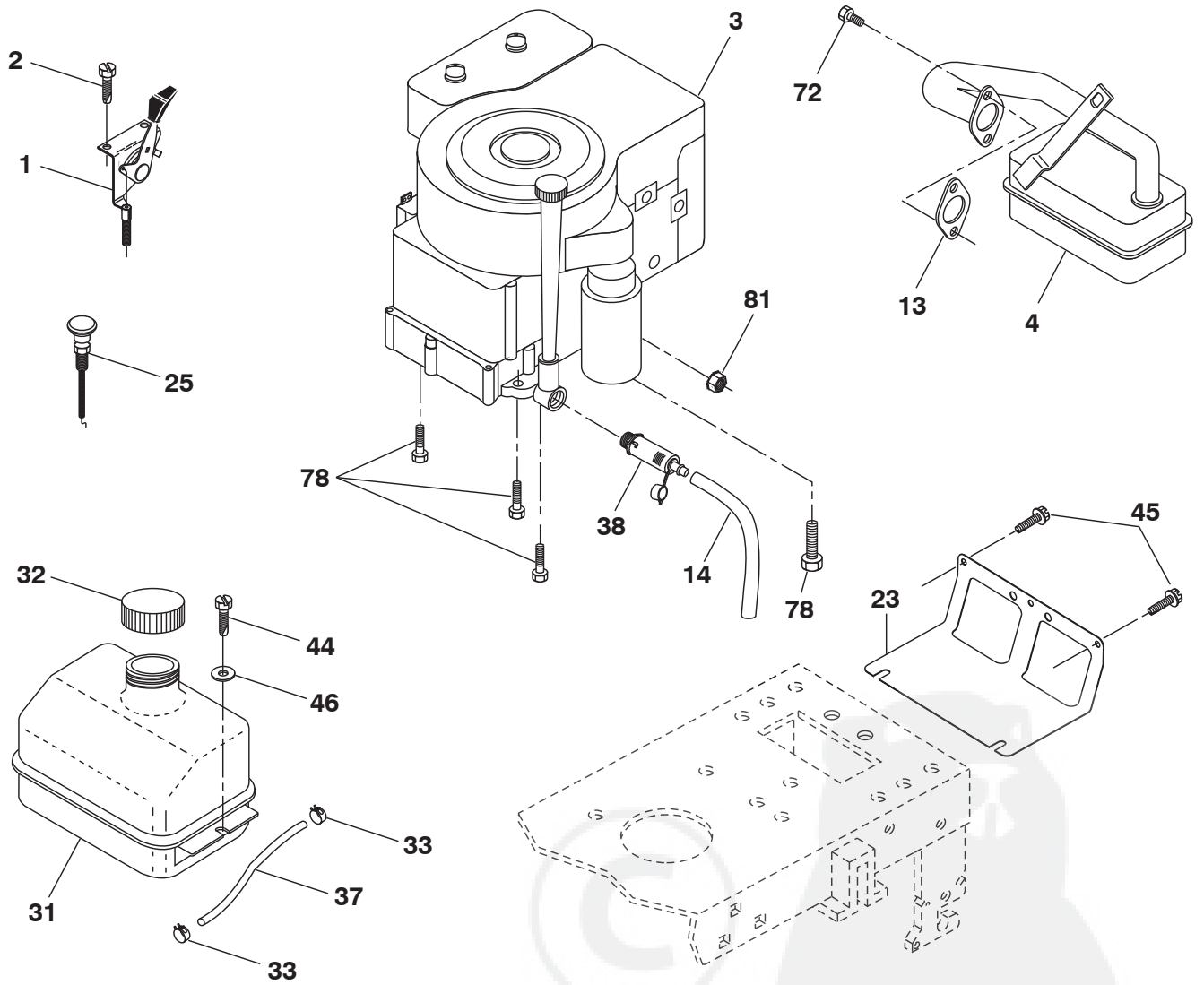

29

OPTIONAL EQUIPMENT
Spark Arrester

engine-bs.1cyl_37

**TRACTOR--MODEL NO. GARDOL 185107HRB (96061021500), PRODUCT NO. 96061 02-15
ENGINE 24**

KEY NO.	PART NO.	DESCRIPTION
1	532 18 38-97	Control Throt /Ch
2	532 19 16-11	Screw 10 x3/4 Single Lead Hex
3	-----	Engine B&S Model 31N707-0430-B1
4	532 13 73-52	Muffler Exhaust B&S LT
13	532 16 52-91	Gasket 1 313 Id Tin Plated
14	532 14 84-56	Tube Drain Oil Easy
23	532 16 98-37	Shield Browning/Debris Guard
25	532 19 49-81	Control Choke
29	532 13 71-80	Arrestor Spark
31	532 40 75-52	Tank Fuel
32	532 19 77-25	Cap Asm Fule Top
33	532 12 34-87	Clamp Hose Blk
37	532 13 70-40	Line Fuel 20"
38	532 18 16-54	Plug Drain Oil Easy
44	817 67 04-12	Screw Hexwsh Thdrol 3/8-16 x 3/4
45	817 00 06-12	Screw 3/8-16 x 3/4
46	819 09 14-16	Washer 9/32 x 7/8 x 16 Ga.
72	532 19 23-34	Screw Socket Head 5/16-18 x 3/4
78	817 06 06-20	Screw 3/8-16 x 1-1/4
81	873 51 04-00	Nut Keps Hex 1/4-20 unc

NOTE: All component dimensions given in U.S. inches
1 inch = 25.4 mm

Engine Power Rating Information

The gross power rating for individual gas engine models is labeled in accordance with SAE (Society of Automotive Engineers) code J11940 (Small Engine Power & Torque Rating Procedure), and rating performance has been obtained and corrected in accordance with SAE J1995 (Revision 2002-5). Actual gross engine power will be lower and is affected by, among other things, ambient operating conditions and engine-to-engine variability. Given both the wide array of products on which engines are placed and the variety of environmental issues applicable to operating the equipment, the gas engine will not develop the rated gross power when used in a given piece of power equipment (actual "on-site" or net horsepower). This difference is due to a variety of factors including, but not limited to, accessories (air cleaner, exhaust, charging, cooling, carburetor, fuel pump, etc.), application limitations, ambient operating conditions (temperature, humidity, altitude), and engine-to-engine variability. Due to manufacturing and capacity limitations, Briggs & Stratton may substitute an engine of higher rated power for this Series engine.

**TRACTOR -- MODEL NO. GARDOL 185107HRB (96061021500), PRODUCT NO. 960 61 02-15
SEAT ASSEMBLY 42**

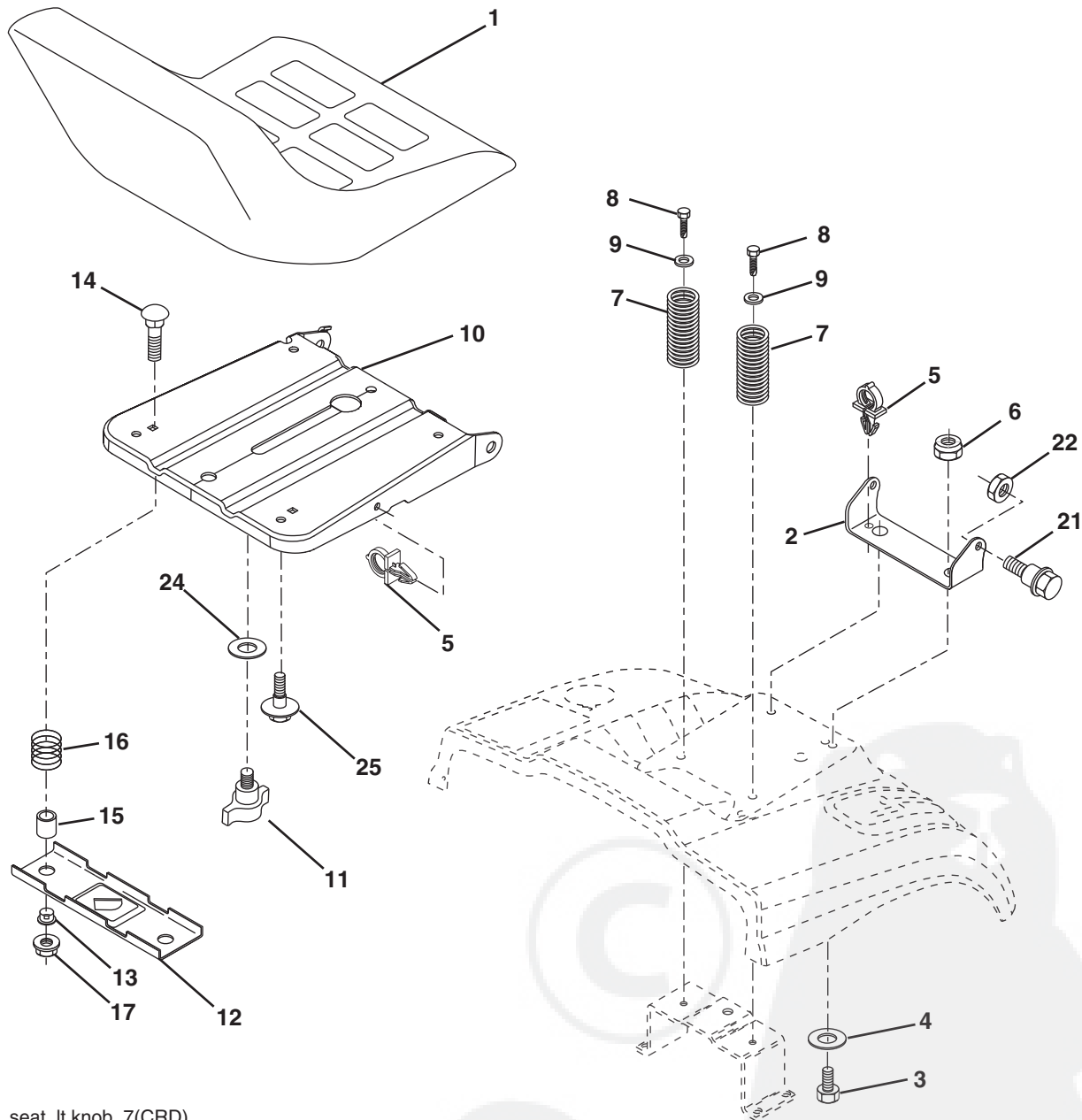

seat_lt.knob_7(CRD)

KEY NO.	PART NO.	DESCRIPTION
1	532 18 87-13	Seat
2	532 14 05-51	Bracket Pnt Pivot Seat (blk)
3	871 11 06-16	Bolt Fin Hex 3/8-16 unc x 1
4	819 13 16-10	Washer Flat 13/32 x 1 x 10 Ga.
5	532 14 50-06	Clip Push In Hinged
6	873 80 06-00	Nut Lock Hex 3/8-16 unc
7	532 12 41-81	Spring Seat Cprsn 2 250 Blk Zi
8	817 00 06-16	Screw 3/8-16 x 1-1/2
9	819 13 16-14	Washer 13/32 x 1 x 14 Ga.
10	532 19 55-30	Pan Pnt Seat (blk)
11	532 16 63-69	Knob Seat
12	532 17 46-48	Bracket Pnt Mounting Switch

KEY NO.	PART NO.	DESCRIPTION
13	532 12 12-48	Bushing Snap Blk Nyl 50 Id
14	872 05 04-12	Bolt Rdhd Sht Nk 1/4-20 x 1-1/2
15	532 13 43-00	Spacer Split
16	532 12 12-50	Spring Cprsn
17	532 12 39-76	Nut Lock 1/4 Lge Flg Gr. 5 Zinc
21	532 17 18-52	Bolt Shoulder 5/16-18 unc-2A
22	873 80 05-00	Nut Hex Lock w/Ins 5/16-18
24	819 17 19-12	Washer 17/32 x 1-3/16 x 12 Ga.
25	532 12 70-18	Bolt Shoulder 5/16-18 x .62

NOTE: All component dimensions given in U.S. inches.
1 inch = 25.4 mm

**TRACTOR--MODEL NO. GARDOL 185107HRB (96061021500), PRODUCT NO. 96061 02-15
MOWER LIFT 45**

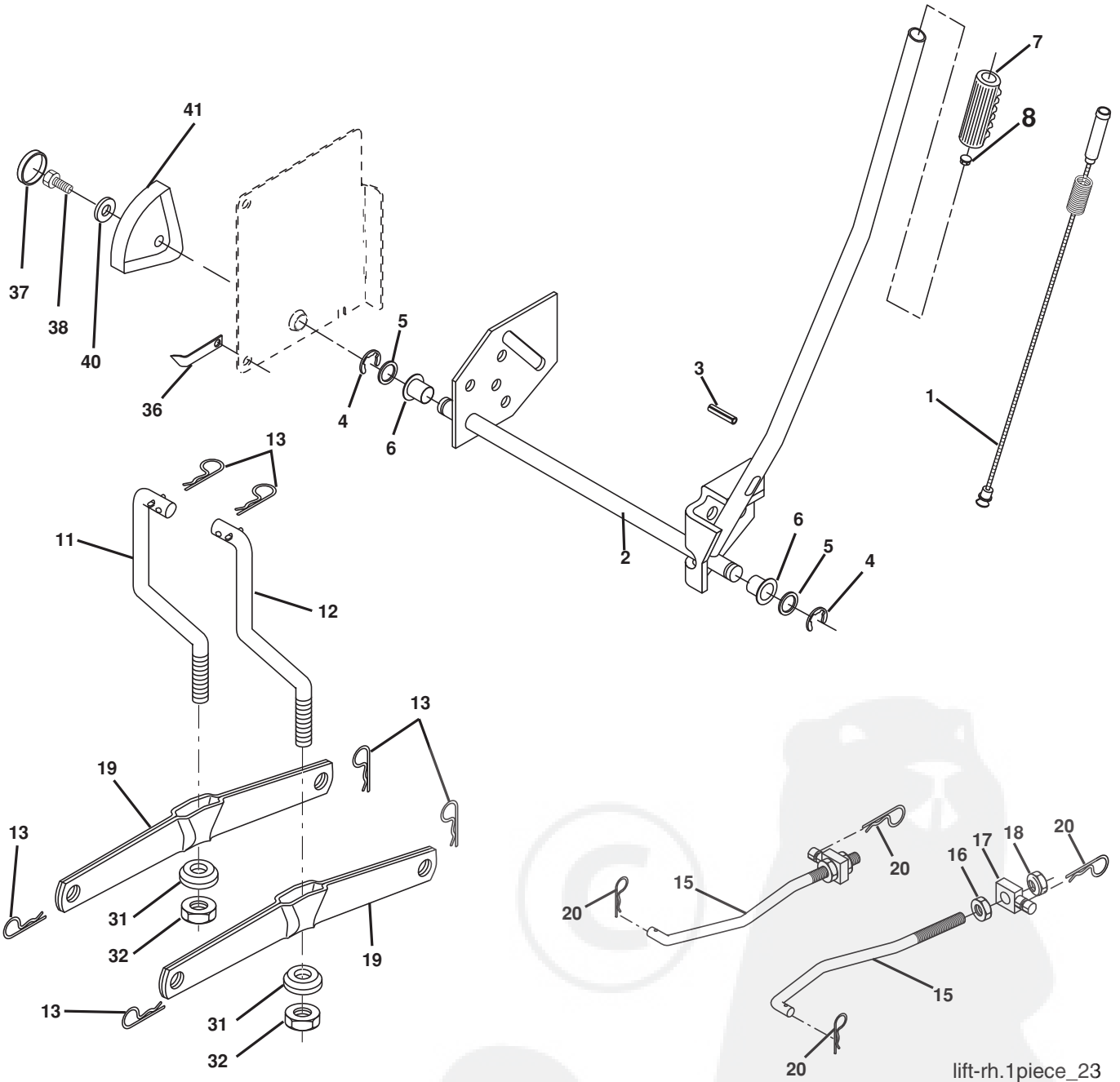

lift-rh.1piece_23

KEY NO.	PART NO.	DESCRIPTION
1	532 19 84-17	Washer Asm Inner Spring W/ Plunger
2	532 19 80-70	Shaft Asm. Lift
3	532 18 88-22	Pin Groove
4	812 00 00-02	E Ring #5133-62
5	819 21 16-21	Washer 21/32 x 1 x 21 Ga.
6	532 12 01-83	Bearing Nylon
7	532 10 94-13	Grip Handle Bicycle
8	532 12 45-26	Button Plunger Black
11	532 16 58-29	Link Asm Lift L.H.
12	532 16 58-31	Link Asm Lift R.H.
13	532 12 46-70	Retainer Spring
15	532 17 32-88	Link Front
16	873 35 08-00	Nut Jam Hex 1/2-13 unc

KEY NO.	PART NO.	DESCRIPTION
17	532 17 56-89	Trunnion Blk Zinc
18	873 80 08-00	Nut Lock w/Wsh 1/2-13 unc
19	532 13 98-68	Arm Suspension Mower
20	532 19 42-09	Pin Cotter 7/16 Bowtie Lock
31	532 16 98-65	Bearing, Pvt. Lift.
32	873 54 06-00	Nut Crownlock 3/8-24
36	532 15 50-97	Pointer Height Indicator
37	532 12 39-35	Plug Hole
38	817 06 05-16	Screw 5/16-18 x 1
40	819 11 24-10	Washer 11/32 x 1-1/2 10 Ga.
41	532 12 39-34	Scale Ind. Height

NOTE: All component dimensions given in U.S. inches
1 inch = 25.4 mm

TRACTOR -- MODEL NO. GARDOL 185107HRB (96061021500), PRODUCT NO. 960 61 02-15
MOWER DECK **44**

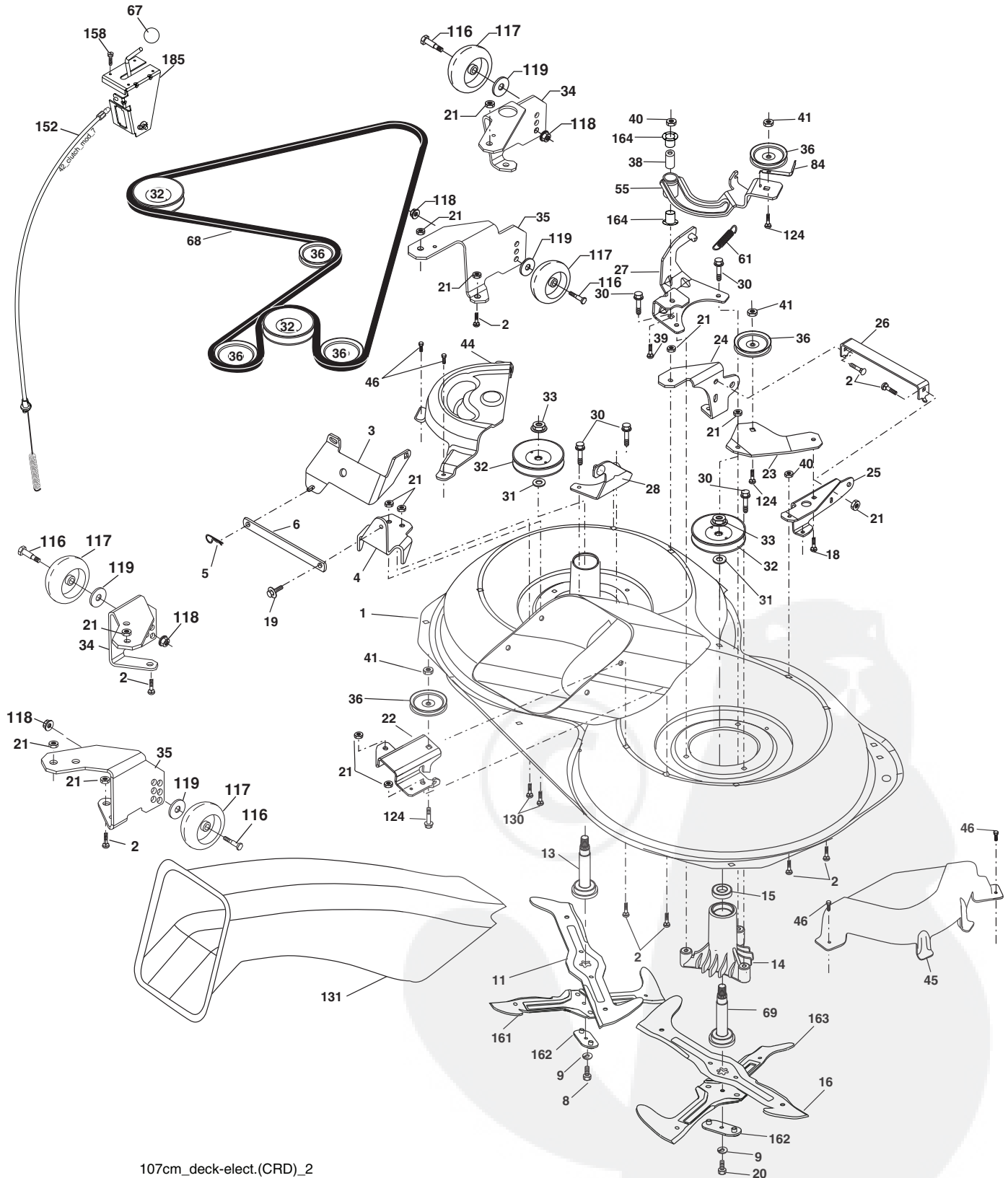

107cm_deck-elect.(CRD)_2

**TRACTOR--MODEL NO. GARDOL 185107HRB (96061021500), PRODUCT NO. 9606102-15
MOWER DECK 44**

KEY NO.	PART NO.	DESCRIPTION	KEY NO.	PART NO.	DESCRIPTION
1	532 16 91-60	Housing Asm. Mower	36	532 14 67-63	Pulley Idler V-Groove Dim 4.25
2	872 14 05-06	Bolt Rdhd Sqnk 5/16-18 unc x 3/4	38	532 16 98-51	Spacer Hub Arm Idler
3	532 16 55-69	Bracket Asm. S-Bar Chass	39	872 11 06-22	Bolt RhHd 3/8-16 unc x 2-3/4 Gr.5
4	532 16 91-67	Bracket Bar Sway Deck	40	873 68 06-00	Nut Crownlock 3/8-16 unc
5	532 12 46-70	Retainer Spring	41	873 90 06-00	Nut Flangelock 3/8-16 unc
6	532 16 55-57	Bar Sway	44	532 17 55-38	Cover Mandrel Lh
8	532 18 17-12	Bolt 3/8-24 x 1.25 Gr. 8 Patched	45	532 17 55-39	Cover Mandrel Rh
9	810 03 06-00	Washer Lock Hvy 3/8 Unplated	46	532 13 77-29	Screw Thd Roll 1/4-20 x 5/8
11	532 18 05-83	Blade 3-1 Lh	55	532 16 98-49	Arm Idler
13	532 13 76-45	Shaft Asm. W/Lower Bearing	61	532 19 94-87	Spring Tension Belt
14	532 12 87-74	Housing Mandrel Vented (Machd)	67	532 10 69-32	Knob
15	532 11 04-85	Bearing Ball Mandrel	68	532 40 20-09	Hex-Belt Mower
16	532 18 05-84	Blade 3-1 Rh	69	532 16 54-82	Shaft Asm W/Lwr Brg Rh Thd CRD
18	872 11 06-06	Bolt Rdhd Sqnk 3/8-16 x 3/4 Gr. 5	84	532 15 60-85	Keeper Belt Idler
19	532 13 28-27	Bolt Shoulder 5/16-18 Thd Form	116	532 19 34-06	Bolt Shoulder
20	532 18 17-13	Bolt 3/8-24 x 1.25 Gr. 8 Ptch Lhthd	117	532 17 48-73	Wheel Gage
21	873 68 05-00	Nut Crown Lock 5/16-18	118	873 93 06-00	Nut Centerlock 3/8-16 unc
22	532 16 91-65	Bracket Idler Sprt RR	119	819 12 14-14	Washer 3/8 x 7/8 x 14 Ga.
23	532 16 91-66	Bracket Idler Sprt RF	124	872 11 06-12	Bolt Carr Sh 3/8-16 x 1-1/2 Gr5
24	532 16 91-70	Bracket Suspension LF	130	872 11 05-06	Bolt Rdhdsqnk 5/16-18 unc x 3/4
25	532 40 01-05	Bracket Suspension RF	131	532 16 56-61	Chute Bagger CRD 92cm
26	532 40 01-10	Brace Susp Frt CRD	152	532 17 60-74	Cable Clutch
27	532 16 91-72	Bracket Asm. Susp RR	158	532 19 16-11	Screw 1/4-20 x 1/2
28	532 16 91-68	Bracket Asm. Susp LR	161	532 18 04-24	Blade Cross LH 107
30	532 17 39-84	Screw Thd Rolling Dod.PT Hex	162	532 18 08-78	Adapter Weldment Blade 107
31	532 18 76-90	Washer Spacer Mower Vented	163	532 18 04-25	Blade Cross RH 107
32	532 19 81-45	Mandrel Pulleys	164	532 12 49-37	Bearing
33	532 40 02-34	Nut Flg Top Lock	185	532 18 82-34	Head Asm Cable Clutch
34	532 40 01-03	Bracket Gauge Wheel Lf	--	532 18 18-57	Mandrel Asm Service
35	532 40 01-04	Bracket Gauge Wheel Rf	--	532 18 18-58	Mandrel Asm CRD Lh Threads VC
			--	532 40 03-25	Replacement Mower Complete

NOTE: All component dimensions given in U.S. inches
1 inch = 25.4 mm

TRACTOR -- MODEL NO. GARDOL 185107HRB (96061021500), PRODUCT NO. 960 61 02-15
BAGGER **46**

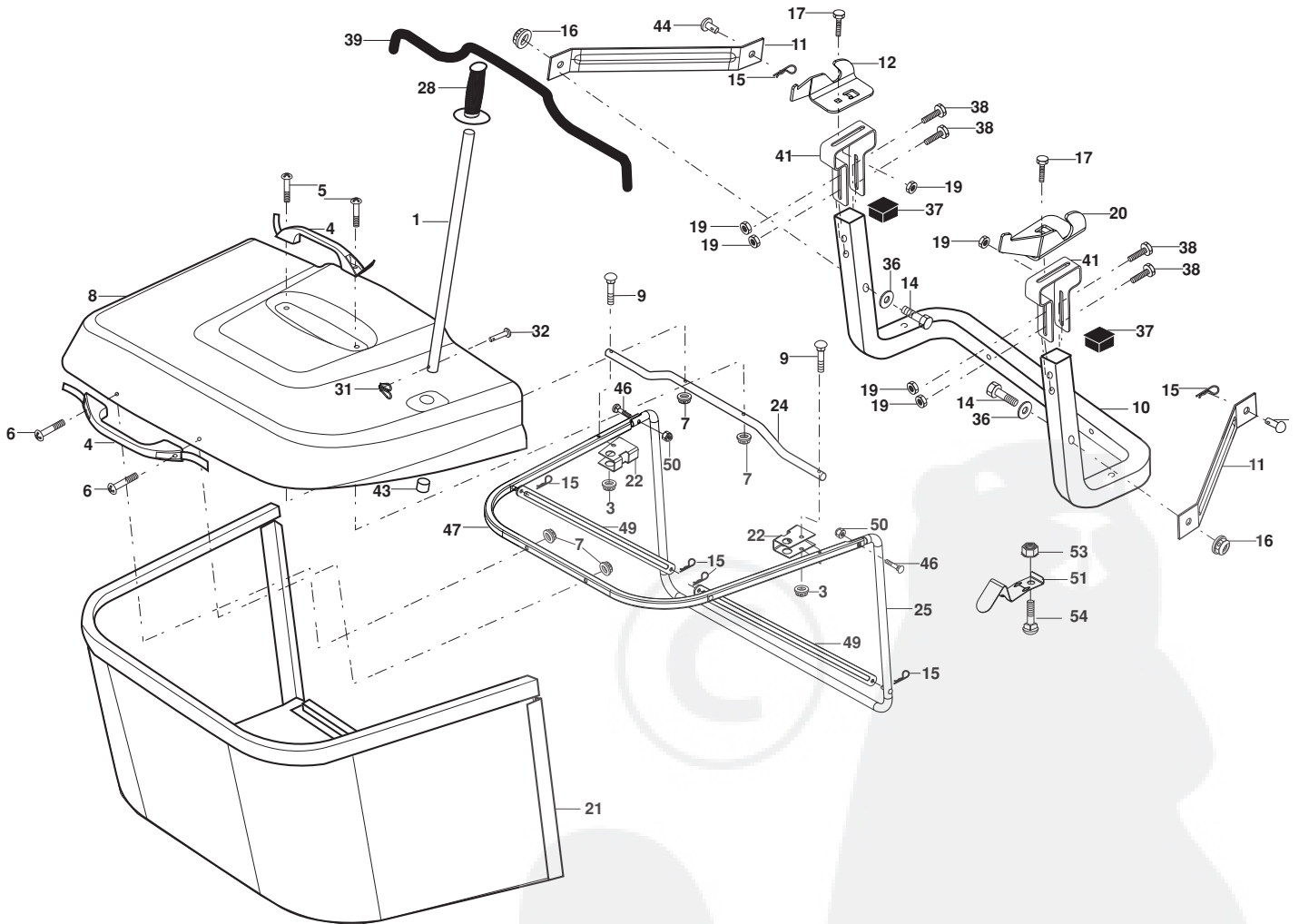

Bagger Asy (CRD)_12

**TRACTOR--MODEL NO. GARDOL 185107HRB (96061021500), PRODUCT NO. 9606102-15
BAGGER 46**

KEY NO.	PART NO.	DESCRIPTION
1	532 16 52-49	Tube Handle Bagger CRD
3	532 12 39-76	Nut Lock 1/4 Lge Flg Gr. 5 Zinc
4	532 16 99-16	Handle Bagger w/Lvrs Gr. 5 Zinc
5	874 98 10-24	Screw Pan Head #10-24 x 1.50 Blk
6	874 98 10-32	Screw Pan Hd
7	873 40 10-00	Nut Wiz Lock Hex Serr/Hd #10-24
8	532 18 25-14	Cover Bagger Steel
9	872 14 04-18	Bolt Carriage 1/4-20 x 2.25d x Gr. 5
10	532 18 12-82	Tube Support Bagger CRD
11	532 16 57-19	Bracket Support Upper Bag CRD
12	532 18 88-48	Bracket Pivot LH
14	874 52 06-36	Bolt Fin Hex 3/8-16 x 2 x 1/4 Gr.5
16	873 90 06-00	Nut Fock Flg 3/8-16 unc
17	872 14 05-06	Bolt Rdhd Sht Sqnk 5/16-18 unc x 3/4
19	873 90 05-00	Nut Lock Hex Flange 5/16-18
20	532 18 88-47	Bracket Pivot RH
21	532 40 61-80	Bag Asm CRD
22	532 16 57-81	Bracket Side Bagger CRD
24	532 16 57-83	Tube Pivot Bagger CRD
25	532 19 37-05	Tube Front Bagger CRD
28	532 16 57-87	Grip Handle Black
31	532 16 94-84	Retainer Clip
32	532 12 68-75	Rivet Rd Hd Drilled 3/8 Dia
36	819 13 20-12	Washer 13/32 x 1-1/4 x 12 Ga.
37	532 17 54-01	Plug Support Bagger CRD
38	872 01 05-20	Bolt 5/16-18 x 2-1/2
39	532 18 09-85	Seal Trim 37"
41	532 16 96-83	Bracket Vert Adj Bagger CRD
43	532 17 40-83	Plug Tubing End
44	532 19 33-12	Pin Clevis 3/8 x 11/16
46	872 11 05-10	Bolt Carr. 5/16-18 x 1-1/4 Gr.5
47	532 19 37-04	Tube Upper Bagger
49	532 19 33-05	Bar Spreader Bagger
50	873 80 05-00	Nut Lock Hex w/insert 5/16-18 unc
51	532 19 99-03	Latch Spring Bagger
53	873 51 04-00	Nut Keps Hex 1/4-20 unc
54	872 14 04-06	Bolt RDHD SQNK 1/4-20 x 3/4 Gr.5

NOTE: All component dimensions given in U.S. inches
1 inch = 25.4 mm