



REPAIR PARTS MANUAL
MODEL NO. LZ12597RB (96061029700)
Lawn Tractor

LAZER[®]

HOW TO USE THIS MANUAL

This manual is designed to provide the customer with a means to identify the parts on his/her tractor when ordering repair parts. The illustrations may or may not represent the actual assemblies; therefore, it is not recommended to use this manual as a guide to assemble or disassemble the tractor. Some hardware and parts are drawn larger in order to more readily identify them.

Each tractor has its own model number.

The model number for your tractor can be found on the fender under the seat.

When ordering parts, always give the following information:

- Product - "Tractor"
- Model Number - "LZ12597RB (96061029700)"
- Part Number
- Part Description

TABLE OF CONTENTS

SCHEMATIC	3
ELECTRICAL.....	4-5
CHASSIS AND ENCLOSURES.....	6-7
DRIVE.....	8-9
ENGINE.....	10-11
STEERING ASSEMBLY.....	12-13
MOWER	14-15
MOWER LIFT.....	16
SEAT ASSEMBLY.....	17
DECALS.....	18
BAGGER.....	19

TRACTOR- -MODEL NO. LZ12597RB (96061029700), PRODUCT NO. 960 61 02-97 SCHEMATIC

SCH09

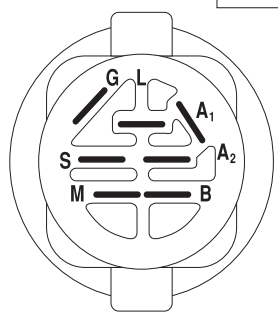
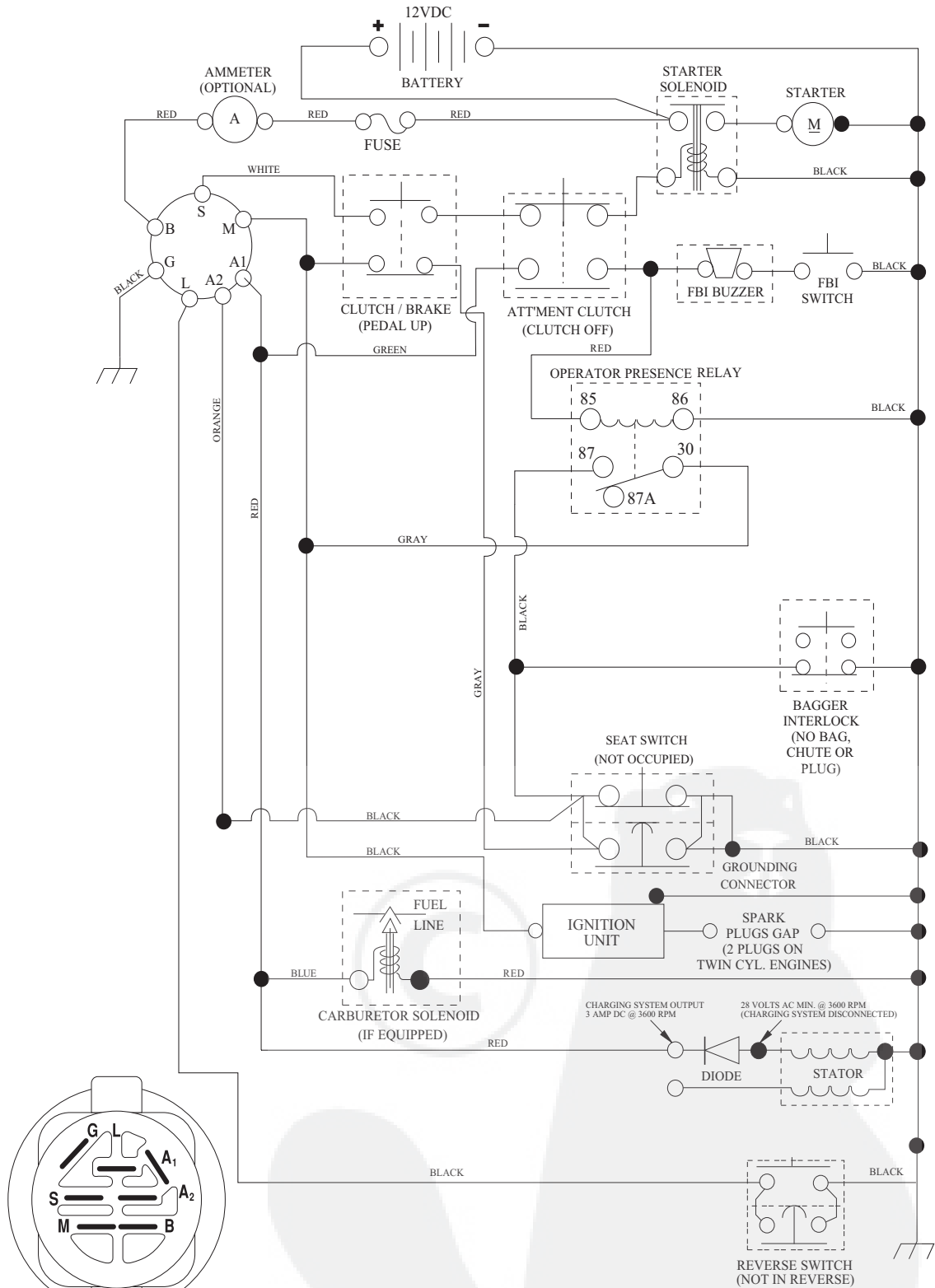

IGNITION SWITCH

POSITION	CIRCUIT	"MAKE"
OFF	M+G+A1	
RUN/OVERRIDE	B+A1	
RUN	B+A1	L+A2
START	B + S + A1	

WIRING INSULATED CLIPS
NOTE: IF WIRING INSULATED CLIPS WERE REMOVED FOR SERVICING OF UNIT, THEY SHOULD BE RE-INSTALLED TO PROPERLY SECURE YOUR WIRING.

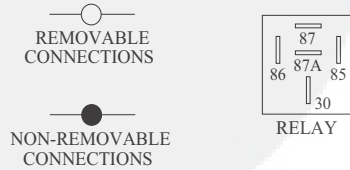

REPAIR PARTS

TRACTOR- -MODEL NO. LZ12597RB (96061029700), PRODUCT NO. 960 61 02-97
ELECTRICAL

C02

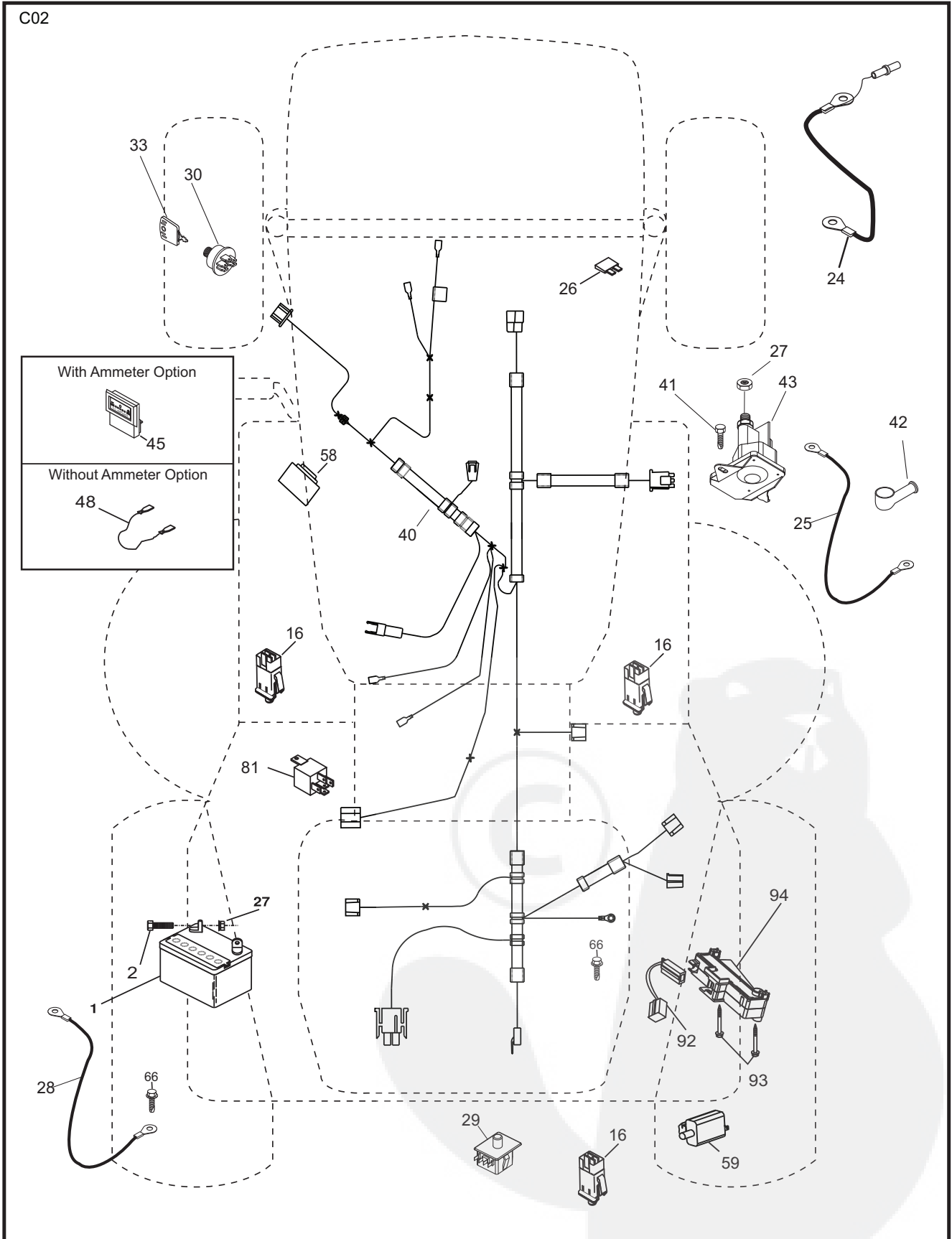

REPAIR PARTS

TRACTOR- -MODEL NO. LZ12597RB (96061029700), PRODUCT NO. 960 61 02-97
ELECTRICAL

KEY NO.	PART NO.	DESCRIPTION
1	532 16 34-65	Battery
2	874 76 04-12	Bolt Hex Hd 1/4-20 unc x 3/4
16	532 17 61-38	Switch Interlock Push-In
24	532 42 12-99	Cable Starter 6 Ga. 11" Red
25	532 16 59-87	Cable Battery CRD 56" Red
26	532 17 51-58	Fuse 20 Amp
27	873 51 04-00	Nut Keps Hex 1/4-20 unc
28	532 12 77-25	Cable Ground 6 Ga.18" Black
29	532 19 27-49	Switch Seat
30	532 19 33-50	Switch Ignition
33	532 41 19-35	Key/Chain
40	532 19 74-38	Harness Ignition
41	871 11 04-08	Bolt Flk Fin Hex 1/4-20 unc x 1/2
42	532 13 15-63	Cover Terminal Red
43	532 19 25-07	Solenoid
48	532 14 08-44	Adapter Ammeter Rectangular
58	532 16 94-19	Buzzer CRD
59	532 18 03-79	Switch FBI CRD
66	817 49 06-08	Screw Thdrol 3/8-16 x 1/2 Ty-Tt
81	532 10 97-48	Relay Asm.
92	532 19 66-15	Harness Pigtail Console ROS
93	532 19 25-40	Screw Plastite 10-14 x 2.0
94	532 19 18-34	Module Reverse ROS

NOTE: All component dimensions given in U.S. inches.
1 inch = 25.4 mm.

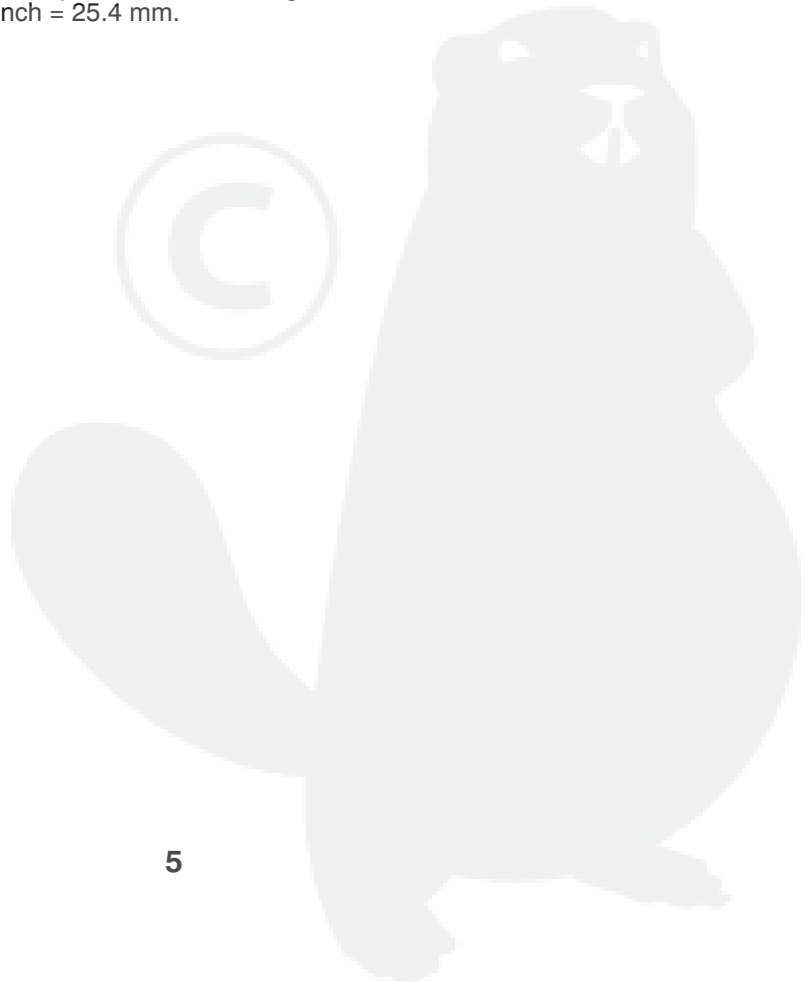
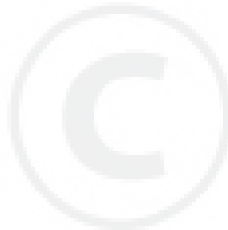

REPAIR PARTS

TRACTOR- -MODEL NO. LZ12597RB (96061029700), PRODUCT NO. 960 61 02-97
CHASSIS AND ENCLOSURES

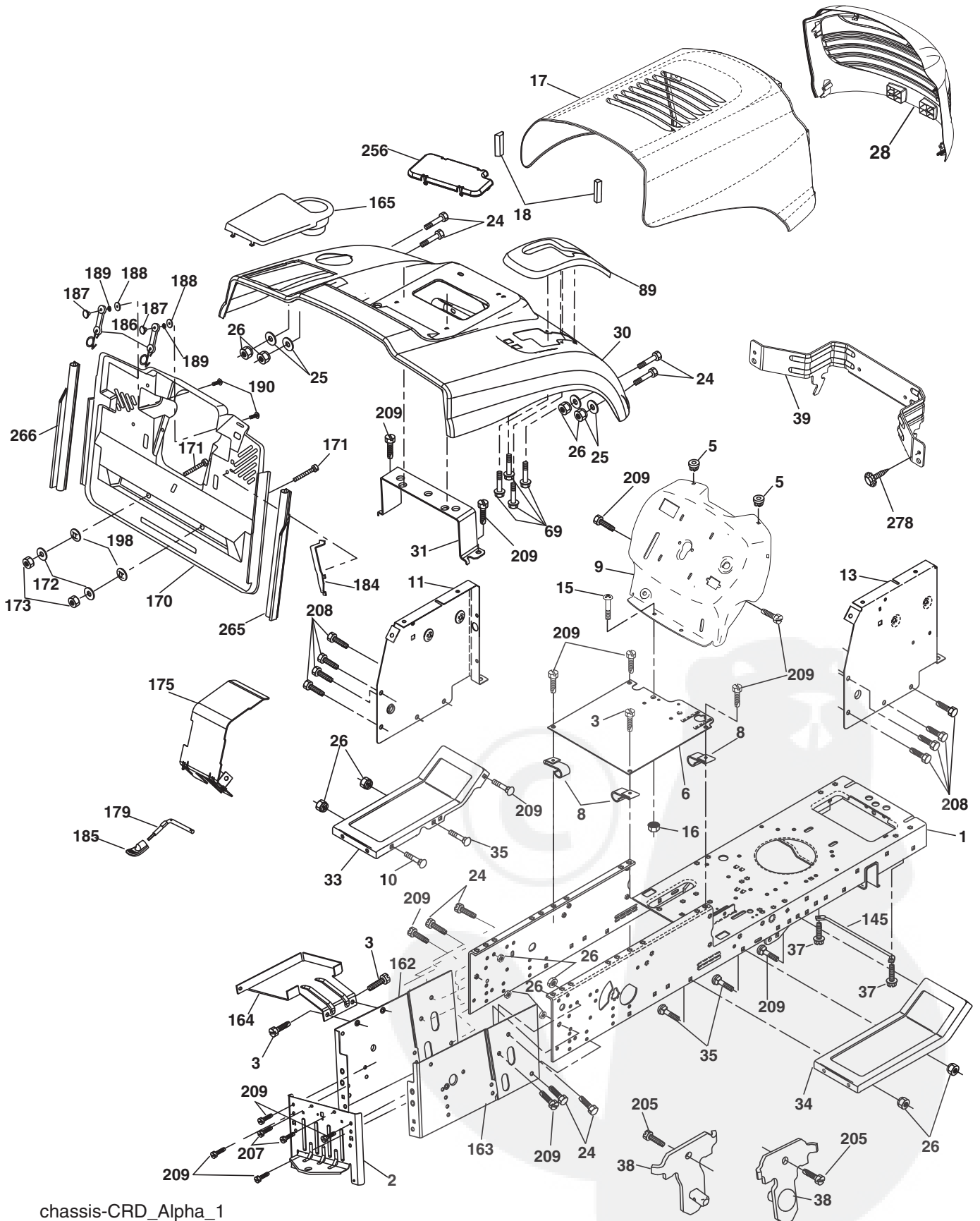

chassis-CRD_Alpha_1

REPAIR PARTS

TRACTOR- -MODEL NO. LZ12597RB (96061029700), PRODUCT NO. 960 61 02-97 CHASSIS AND ENCLOSURES

KEY NO.	PART NO.	DESCRIPTION	KEY NO.	PART NO.	DESCRIPTION
1	532 17 46-20	Chassis	165	532 18 13-56	Cover Battery CRD Lt.
2	532 18 03-84	Drawbar	170	532 19 94-88	Backplate CRD
3	817 06 06-12	Screw 3/8-16 x .75	171	872 14 06-20	Bolt Rdhd Sqnk 3/8-16 x 2-1/2 Gr. 5
5	532 15 52-72	Bumper Hood/Dash	172	819 13 20-16	Washer 13/32 x 1-1/4 x 16 Ga.
6	532 18 44-19	Saddle	173	873 51 06-00	Nut, Keps Hex 3/8-16 unc
8	532 12 64-71	Clip Insulator 13/32 Mtg. Hole	175	532 18 82-03	Trap Door CRD
9	532 19 46-88	Dash	179	532 18 82-02	Rod Pivot FBI CRD
10	872 14 06-08	Bolt, Carriage 3/8-16 x 3/4	184	532 17 46-62	Bracket Actuator Bagger CRD
11	532 17 49-96	Panel, Dash, L.H.	185	532 18 11-01	Knob Rod
13	532 18 17-19	Panel, Asm. Dash, R.H.	186	532 16 07-93	Latch Asm. Multch Bagger
15	874 18 05-12	Screw, Machine, Truss Head 5/16-18 unc x 3/4	187	532 12 50-04	Nut Weld .327/.304 #10-24
16	873 51 05-00	Nut	188	819 06 12-16	Washer #10
17	532 19 47-97	Hood Assembly	189	810 07 10-00	Washer Lock #10
18	532 18 49-21	Bumper Hood	190	871 08 10-10	Screw Pan Hd. Phillips 10-24 x 5/8
24	874 78 06-16	Bolt	198	532 16 89-37	Nut Push
25	819 13 13-12	Washer 13/32 x 13/16 x 12 Ga.	205	817 49 06-08	Screw 3/8-16 x 1/2
26	873 80 06-00	Nut	207	817 67 05-08	Screw 5/16-18 x 1/2
28	532 19 47-98	Grille	208	817 67 06-08	Screw Thdrol 3/8-16 x 1/2
30	532 19 73-44	Fender	209	817 00 06-12	Screw Hex Wsh. Thdrol 3/8-16 x 3/4
31	532 16 51-56	Bracket, Fender Support	256	532 18 13-61	Cover Fender Rack CRD
33	532 18 11-93	Footrest, L.H.	265	532 18 57-04	Seal RH Side Bagger
34	532 18 11-94	Footrest, R.H.	266	532 18 57-03	Seal LH Side Bagger
35	872 11 06-06	Bolt	278	532 41 63-58	Screw #10 x 0.750
37	817 49 05-08	Screw Thdrol 5/16-18 x 1/2 TYT	--	532 19 39-35	Plug Switch Light
38	532 18 17-48	Bracket Asm. Pivot Mower Rear	--	532 00 54-79	Plug, Button
39	532 18 75-68	Bracket Pivot			
69	532 14 24-32	Screw Hex 1/4-1/2			
89	532 19 73-39	Console			
145	532 40 91-67	Rod Pivot Chassis/Hood			
162	532 18 03-82	Bracket Exten. Chassis LH CRD			
163	532 18 03-83	Bracket Exten. Chassis RH CRD			
164	532 16 56-05	Support Battery CRD			

NOTE: All component dimensions given in U.S. inches.
1 inch = 25.4 mm.

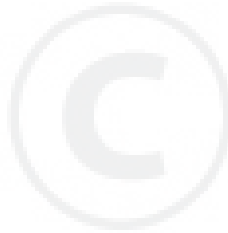

REPAIR PARTS

TRACTOR- -MODEL NO. LZ12597RB (96061029700), PRODUCT NO. 960 61 02-97
DRIVE

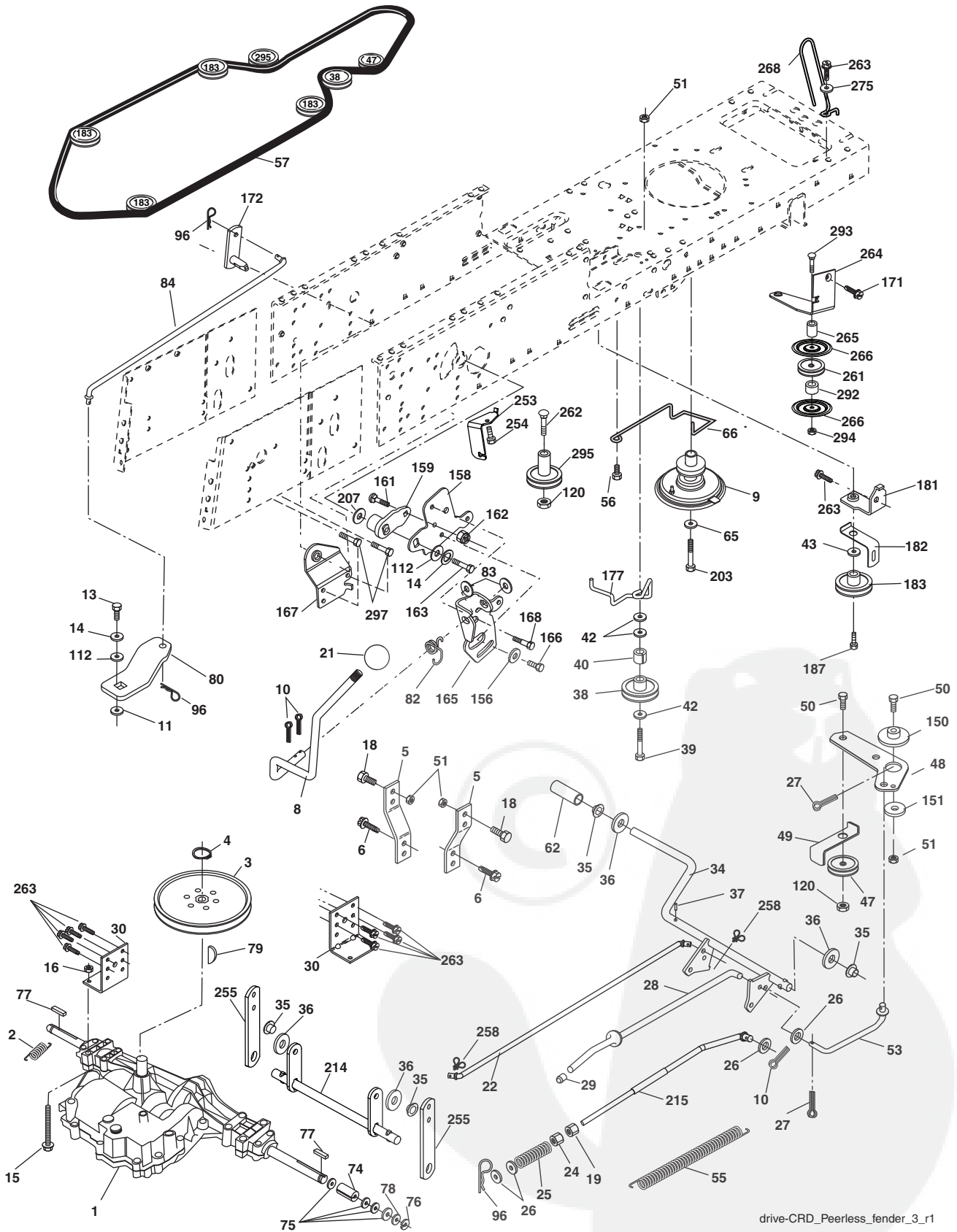

drive-CRD_Peerless_fender_3_r1

REPAIR PARTS

TRACTOR- -MODEL NO. LZ12597RB (96061029700), PRODUCT NO. 960 61 02-97 DRIVE

KEY NO.	PART NO.	DESCRIPTION	KEY NO.	PART NO.	DESCRIPTION
1	-----	Transaxle Peerless 206-546	79	532 12 50-96	Key Woodruff
2	532 14 66-82	Spring Brake Return	80	532 14 50-90	Arm Shift PMST 20 Tires
3	532 16 59-99	Pulley Transaxle	82	532 16 57-11	Spring, Torsion
4	812 00 00-28	Ring Retainer #5100-62	83	819 17 12-16	Washer 17/32 x 3/4 x 16 Ga.
5	532 12 15-20	Strap torque 30 degrees	84	532 16 56-21	Link Shift CRD
6	817 06 05-12	Screw 5/16-18 x 3/4	96	532 12 47-88	Spring, Retainer 1"
8	532 19 27-06	Rod Shift Fender Adjust Lt.	112	819 09 12-10	Washer 9/32 x 3/4 x 10 Ga.
9	532 40 85-79	Clutch Asm. Noram	120	873 90 06-00	Nut Lock 3/8-16
10	876 02 04-16	Pin, Cotter 1/8 x 1	150	532 16 58-50	Bushing, Bellcrank Grnd. Dr.
11	532 10 57-01	Washer Plate Shf .3888 sq. hole	151	819 13 32-10	Washer 13/32 x 2 x 10 Ga.
13	874 55 04-12	Bolt 1/4-28 unf Gr. 8 w/patch	156	532 16 60-02	Washer Srred. 5/16 ID x 1.125
14	810 04 04-00	Washer, Lock Hvy. Helical	158	532 16 55-89	Bracket Shift Mount
15	874 49 05-44	Bolt Hex FGHD 5/16-18 x Gr. 5	159	532 18 39-00	Hub Tapered Flange Shift Lt.
16	873 80 05-00	Nut, Lock Hex w/lns 5/16-18 unc	161	872 14 04-06	Bolt Rdhd Sqnk. 1/4-20 x 3/4 Gr. 5
18	874 78 06-16	Bolt Hex 3/8-16 unc x 1 Gr. 5	162	873 68 04-00	Nut Crownlock 1/4-20 unc
19	873 80 06-00	Nut, Lock Hex w/Wsh. 3/8-16 unc	163	874 78 04-16	Bolt Hex Fin 1/4-20 unc x 1 Gr. 5
21	532 10 69-33	Knob Round 1/2-13 unc Blk.	165	532 16 56-23	Bracket Pivot Lever
22	532 17 56-07	Rod, Brake CRD Main	166	817 49 05-10	Screw 5/16-18 x 5/8
24	873 35 06-00	Nut	167	532 16 55-88	Bracket Support Shift CRD
25	532 10 68-88	Spring, Rod, Brake	168	532 16 54-92	Bolt Shoulder 5/16-18 x .561
26	819 13 13-16	Washer 13/32 x 13/16 x 16 Ga.	171	817 49 06-08	Screw Thdrol. 3/8-16 x 1/2 Ty-Tt
27	876 02 04-12	Pin, Cotter 1/8 x 3/4	172	532 16 56-35	Shaft Asm. Shift Front CRD
28	532 17 57-65	Rod, Parking Brake	177	532 16 59-32	Keeper Flat Idler 3.06 CRD
29	532 07 16-73	Cap, Parking Brake	181	532 18 02-11	Bracket Idler Ground Drive CRD
30	532 17 49-73	Bracket, Mfg. Transaxle	182	532 18 26-82	Keeper Belt 2.5 Od V-Idler CRD
34	532 17 55-78	Shaft, Asm. Pedal Foot CRD	183	532 19 95-34	Pulley V-Idler
35	532 12 01-83	Bearing, Nylon	187	817 58 05-20	Screw 5/16-18 x 1.25
36	819 21 16-16	Washer 21/32 x 1 x 16 Ga.	203	871 17 07-80	Bolt Hex 7/16-20 x 5
37	532 12 49-63	Pin, Roll 3/16 x 1 "	207	532 16 98-45	Washer Nylon
38	532 16 59-36	Pulley, Flat	214	532 17 56-09	Shaft Asm. Brake
39	874 76 06-44	Bolt Fin Hex 3/8-16 unc x 2-3/4	215	532 41 01-42	Rod Brake Secondary
40	532 12 49-65	Spacer, Split 395 x 59 Bzp	253	532 17 50-28	Bracket Cable Chassis
42	819 13 13-12	Washer 13/32 x 13/16 x 12 Ga.	254	817 00 06-16	Screw 3/8-16 x 1
43	819 11 10-12	Washer 11/32 x 5/8 x 12 Ga.	255	532 17 56-08	Brace Shaft Brake
47	532 12 77-83	Pulley, Idler, V Groove Plastic	258	532 17 80-62	Clip Retainer
48	532 15 44-07	Bellcrank Clutch Grnd. Drv.	261	532 13 14-94	Pulley Idler Flat Plated
49	532 12 32-05	Retainer, Belt Style Spring	262	872 11 06-22	Bolt Rdhd. 3/8-16 unc x 2-3/4 Gr. 5
50	872 11 06-12	Bolt Carr. Sh. 3/8-16 x 1-1/2 Gr. 5	263	817 00 06-12	Screw Hex Wsh. THDR 3/8-16 x 3/4
51	873 68 06-00	Nut, Crownlock 3/8-16 unc	264	532 43 11-74	Bracket Idler Chassis
53	532 19 96-52	Link, Clutch 7.66	265	532 40 46-07	Spacer Idler Chassis
55	532 10 57-09	Spring, Return, Clutch	266	532 18 20-61	Shield Idler
56	817 06 06-20	Screw 3/8-16 x 1-1/4	268	532 18 24-02	Guard Muffler OHV B&S RH
57	532 16 56-31	V-Belt CRD	275	819 13 16-14	Washer 13/32 x 1 x 14 Ga.
62	532 12 48-72	Cover, Pedal	292	532 40 02-71	Spacer Noram
65	810 04 07-00	Washer	293	872 14 06-28	Bolt Rdhd. Sqnk. 3/8-16 x 3-1/2
66	532 15 47-78	Keeper, Belt Engine F-Proof	294	532 19 70-33	Nut Jam 3/8-16
74	532 13 70-57	Spacer Axle	295	532 17 91-14	Pulley Idler Composite
75	532 12 17-49	Washer 25/32 x 1-1/4 x 16 Ga.	297	817 49 06-10	Screw Hxwsh Thdr 3/8-16 x 5/8
76	812 00 00-01	Ring, E			
77	532 12 35-83	Key, Square			
78	532 12 17-48	Washer 25/32 x 1-5/8 x 16 Ga.			

NOTE: All component dimensions given in U.S. inches
1 inch = 25.4 mm

REPAIR PARTS

TRACTOR- -MODEL NO. LZ12597RB (96061029700), PRODUCT NO. 960 61 02-97
ENGINE

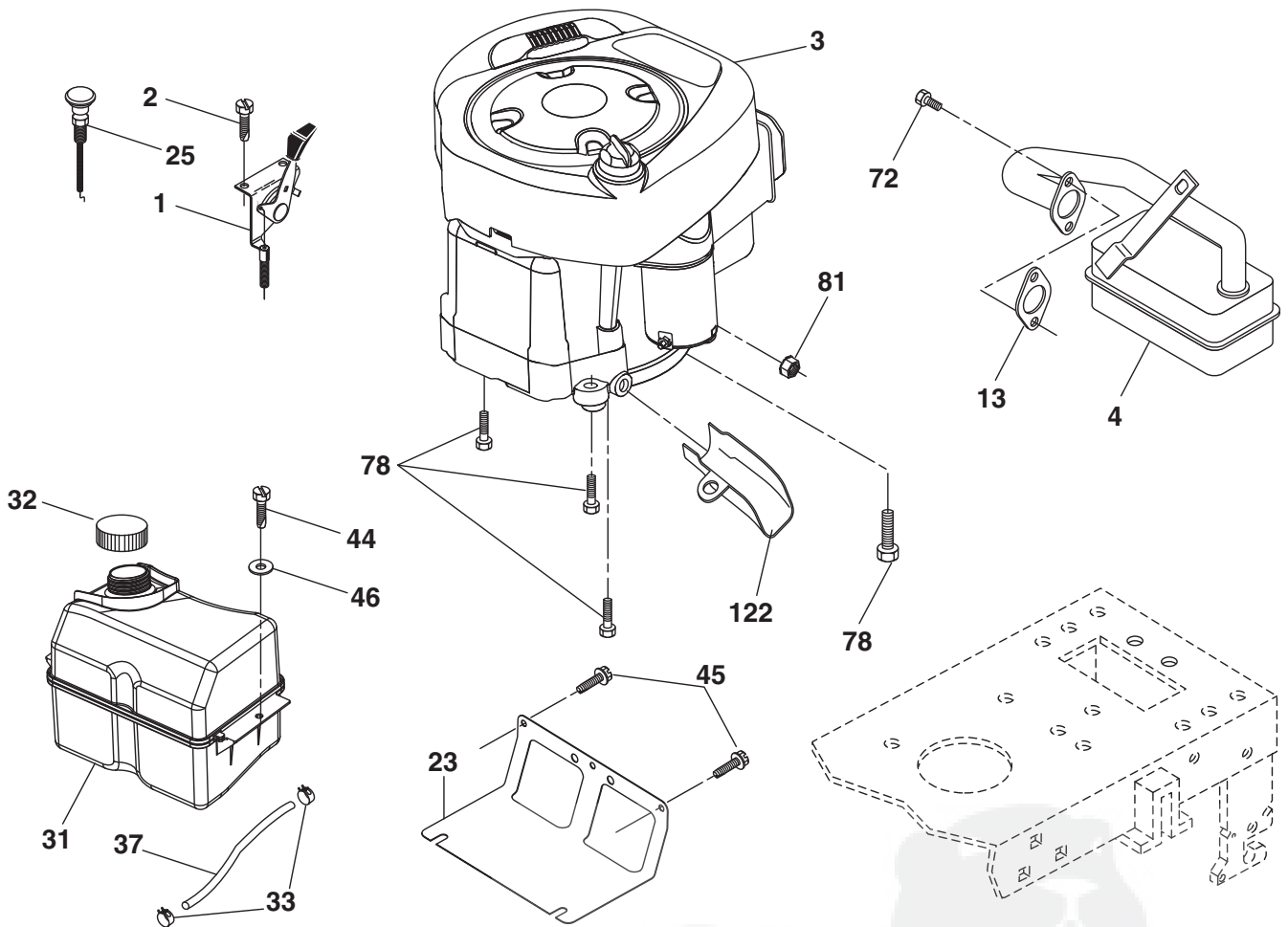

29

OPTIONAL EQUIPMENT

Spark Arrester

engine-CRD_bs_20

REPAIR PARTS

TRACTOR- -MODEL NO. LZ12597RB (96061029700), PRODUCT NO. 960 61 02-97
ENGINE

KEY NO.	PART NO.	DESCRIPTION
1	532 17 05-51	Control Throttle /Choke
2	817 72 04-08	Screw Hex Thd. Cut 1/4-20 x 5/8 T
3	-----	Engine B&S Model 219707-0380-B1
4	532 17 97-58	Muffler Exhaust
13	532 16 52-91	Gasket
23	532 16 98-37	Shield Browning/Debris Guard
25	532 19 06-95	Control Choke
29	532 13 71-80	Arrester Spark
31	532 40 75-51	Tank Fuel
32	532 43 20-20	Cap Asm. Fuel Top
33	532 12 34-87	Clamp Hose Blk.
37	532 13 70-40	Line Fuel 20 "
44	817 67 04-12	Screw Hex. Wsh. Thdrol. 3/8-16 x 3/4
45	817 00 06-12	Screw 3/8-16 x 3/4
46	819 09 14-16	Washer 9/32 x 7/8 x 16 Ga.
72	532 19 23-34	Screw Socket Head 5/16-18 x .75
78	817 06 06-20	Screw 3/8-16 x 1-1/4
81	873 51 04-00	Nut Keps Hex 1/4-20 unc
122	532 42 19-22	Extension Drain Oil

NOTE: All component dimensions given in U.S. inches
1 inch = 25.4 mm

Engine Power Rating Information

The gross power rating for individual gas engine models is labeled in accordance with SAE (Society of Automotive Engineers) code J1940 (Small Engine Power & Torque Rating Procedure), and rating performance has been obtained and corrected in accordance with SAE J1995 (Revision 2002-05). Torque values are derived at 3060 RPM; horsepower values are derived at 3600 RPM. Actual gross engine power will be lower and is affected by, among other things, ambient operating conditions and engine-to-engine variability. Given both the wide array of products on which engines are placed and the variety of environmental issues applicable to operating the equipment, the gas engine will not develop the rated gross power when used in a given piece of power equipment (actual "on-site" or net power). This difference is due to a variety of factors including, but not limited to, accessories (air cleaner, exhaust, charging, cooling, carburetor, fuel pump, etc.), application limitations, ambient operating conditions (temperature, humidity, altitude), and engine-to-engine variability. Due to manufacturing and capacity limitations, Briggs & Stratton may substitute an engine of higher rated power for this Series engine.

REPAIR PARTS

TRACTOR- -MODEL NO. LZ12597RB (96061029700), PRODUCT NO. 960 61 02-97
STEERING ASSEMBLY

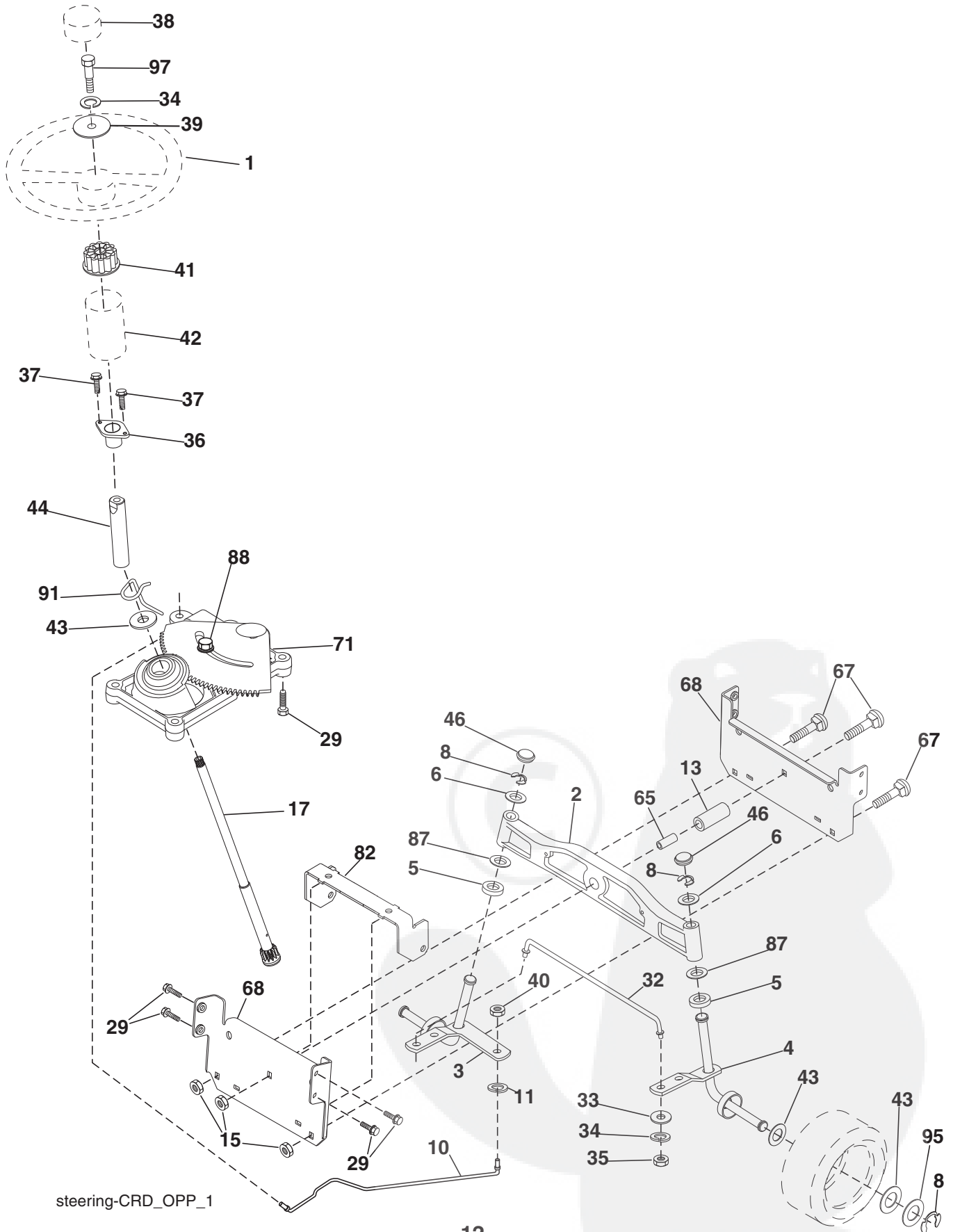

steering-CRD_OPP_1

REPAIR PARTS

TRACTOR- -MODEL NO. LZ12597RB (96061029700), PRODUCT NO. 960 61 02-97
STEERING ASSEMBLY

KEY NO.	PART NO.	DESCRIPTION
1	532 18 67-80	Steering Wheel
2	532 18 47-06	Cast Iron Axle Assembly
3	532 16 98-40	Spindle Assembly, L.H.
4	532 16 98-39	Spindle Assembly, R.H.
5	532 12 49-31	Washer Thrust .75 x 1.230
6	532 12 17-48	Washer 25/32 x 1-5/8 x 16 Ga.
8	812 00 00-29	Ring, Clip
10	532 17 51-21	Link, Drag
11	810 04 06-00	Washer, Lock
13	532 13 65-18	Spacer Brg. Axle Front
15	873 90 06-00	Nut, Lock Flg. 3/8-16
17	532 19 07-53	Shaft, Steering
29	817 00 06-12	Screw, 3/8-16 x 3/4
32	532 17 01-62	Rod, Tie
33	819 11 12-16	Washer 11/32 x 3/4 x 16 Ga.
34	810 04 05-00	Washer Lock Hvy. Hlcl. Spr. 5/16
35	873 54 05-00	Nut Crownlock 5/16-24 unf
36	532 15 50-99	Bushing, Steering
37	532 15 29-27	Screw TT #10-32 x 5 x 3/8 Flange
38	532 19 29-16	Cap Wheel Steer
39	819 11 38-12	Washer 11/32 x 2-3/8 x 12 Ga.
40	873 54 06-00	Nut Crownlock 3/8-24
41	532 18 67-37	Adaptor, Steering Wheel
42	532 16 96-33	Boot, Steering Dash P/L Mtl.
43	532 12 17-49	Washer 25/32 x 1-1/4 x 16 Ga.
44	532 19 07-52	Extension Steering
46	532 12 12-32	Cap, Spindle
65	532 41 47-36	Spacer Brace Axle
67	872 11 06-18	Bolt Rdhd. Sq. 3/8-16 unc x 2-1/4
71	532 17 51-46	Steering Asm.
68	532 16 98-27	Brace Axle
82	532 19 99-78	Bracket Susp. Chassis Front
87	532 17 39-66	Washer Flat .781 x 1-1/2 x .14
88	532 17 51-18	Bolt Shoulder 7/16-20 unc
91	532 17 55-53	Clip Steering
95	532 18 89-67	Washer Harden .793 x 1.637 x 060
97	532 42 89-82	Bolt Fin Hx 5/16-18 x 4

NOTE: All component dimensions given in U.S. inches.
1 inch = 25.4 mm.

REPAIR PARTS

TRACTOR- -MODEL NO. LZ12597RB (96061029700), PRODUCT NO. 960 61 02-97
MOWER

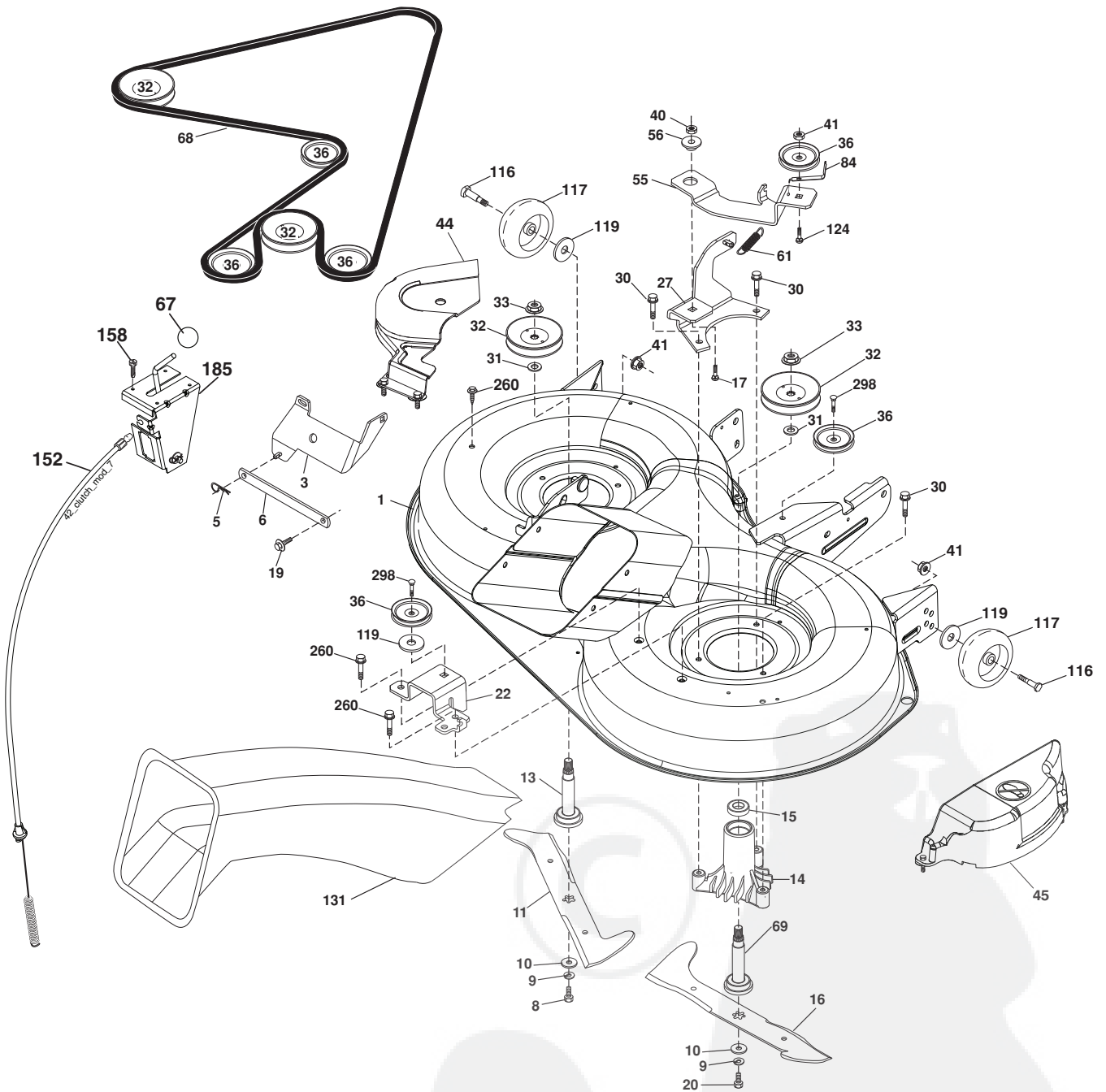

Deck-CRD_97cm_Elect_2_r3

REPAIR PARTS

TRACTOR- -MODEL NO. LZ12597RB (96061029700), PRODUCT NO. 960 61 02-97
MOWER

KEY NO.	PART NO.	DESCRIPTION	KEY NO.	PART NO.	DESCRIPTION
1	532 42 91-21	Housing Asm. Mower	67	532 10 69-32	Knob Rd 3/8-16
3	532 43 18-64	Bracket Asm. S-Bar Chass	68	532 42 95-32	Drive Belt
5	532 12 46-70	Retainer Spring	69	532 16 54-82	Shaft Asm w/Lwr Brg RH Thd
6	532 16 55-57	Bar Sway	84	532 15 60-85	Keeper Belt Idler
8	532 18 17-12	Bolt 3/8-24 x 1.25 Gr. 8 Patched	116	532 19 34-06	Bolt Shoulder
9	810 03 06-00	Washer Lock Hvy 3/8 Unplated	117	532 17 48-73	Wheel Gauge
10	532 14 02-96	Washer Hard Blade Mower Vented	119	819 13 20-12	Washer 13/32 x 1-1/4 x 12 Ga.
11	532 42 79-84	Blade 3-1 LH	124	872 11 06-12	Bolt Carr Sh 3/8-16 x 1-1/2 Gr. 5
13	532 13 76-45	Shaft Asm. w/Lower Bearing	131	532 16 56-61	Chute Bagger
14	532 12 87-74	Housing Mandrel Vented (Machd)	152	532 17 60-74	Cable Clutch CRD
15	532 11 04-85	Bearing Ball Mandrel	158	817 72 04-08	Screw Hex Thd Cut 1/4-20 x 1/2
16	532 42 79-85	Blade 3-1 RH	185	532 18 82-34	Head Asm Cable Clutch
17	872 14 06-10	Bolt Carriage 3/8-16 x 1-1/4	260	817 67 06-08	Screw 3/8-16 x 1/2
19	532 13 28-27	Bolt Shoulder 5/16-18 Thd Form	298	817 49 06-28	Screw 3/8-16 x 1-3/4
20	532 18 17-13	Bolt 3/8-24 x 1.25 Gr. 8 Ptch Lhthd	--	532 18 18-57	Mandrel Assembly (Includes housing, shaft assembly, and bearing only - pulley/nut/washer and blade bolt/washers not included)
22	532 43 11-69	Bracket Idler Sprt Rear RH	--	532 18 18-58	Mandrel Asm CRD LH Threads SVC
27	532 42 79-81	Bracket Asm. Susp. Rear RH	--	532 43 15-80	Replacement Mower, Complete (Std. Deck - Order separately gauge wheel components key nos. 116-119)
30	532 17 39-84	Screw Thd Rolling			
31	532 18 76-90	Washer Spacer Mower Vented			
32	532 15 35-32	Mandrel Pulleys			
33	532 40 02-34	Nut Flg Top Lock			
36	532 14 67-63	Pulley Idler V-Groove Dim 4.25			
40	873 68 06-00	Nut Crownlock 3/8-16 unc			
41	873 90 06-00	Nut Lock Flg. 3/8-16 unc			
44	532 43 11-70	Cover Mandrel LH			
45	532 42 91-66	Cover Mandrel RH			
55	532 19 94-98	Arm Idler			
56	532 16 57-23	Spacer Retainer Mower			
61	532 19 94-86	Spring Tension Belt			

NOTE: All component dimensions given in U.S. inches
1 inch = 25.4 mm

REPAIR PARTS

TRACTOR- -MODEL NO. LZ12597RB (96061029700), PRODUCT NO. 960 61 02-97
MOWER LIFT

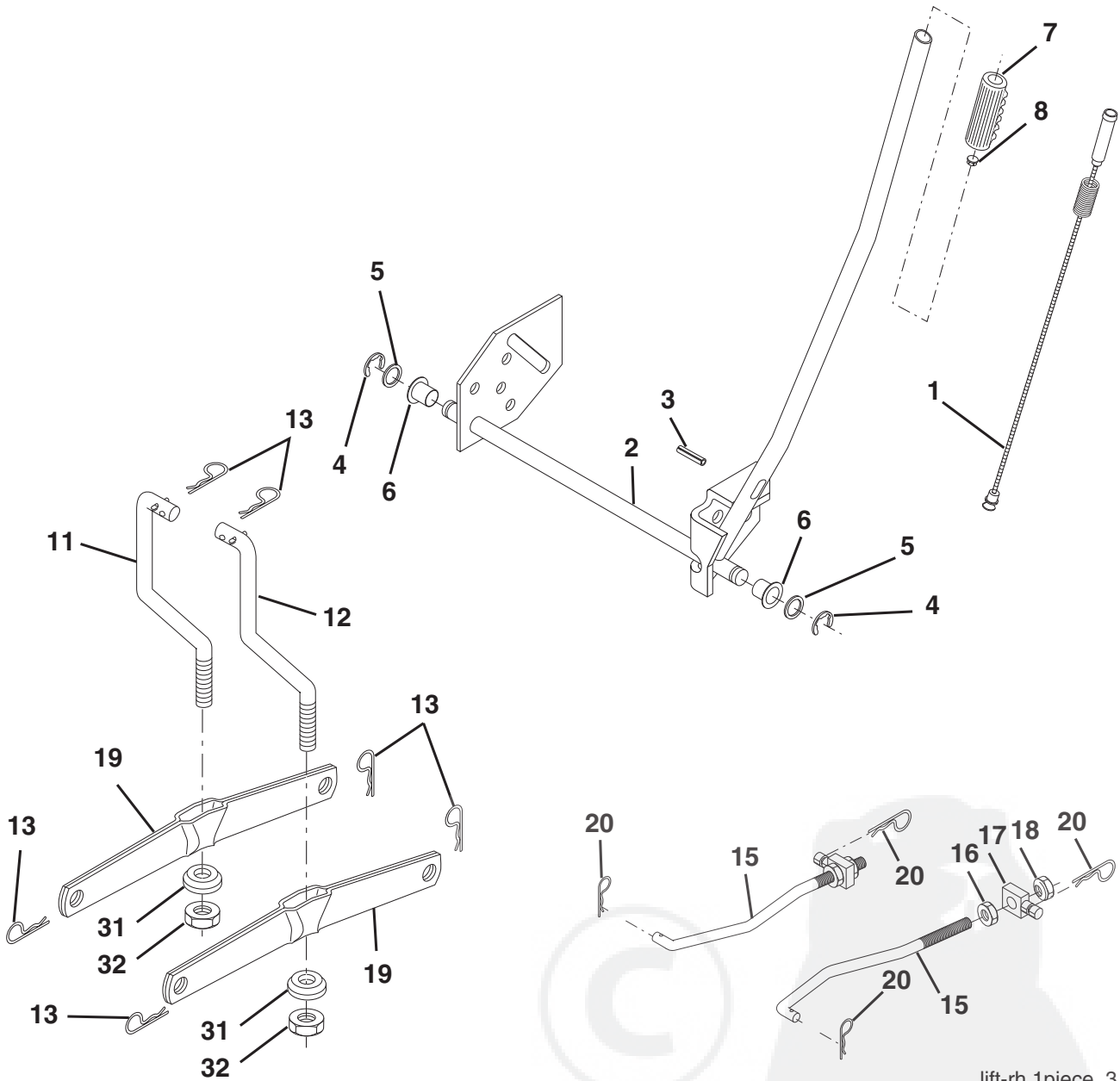

lift-rh.1piece_3

KEY NO.	PART NO.	DESCRIPTION
1	532 40 49-81	Plunger Asm. Lift Lever
2	532 15 94-71	Shaft Asm. Lift
3	532 10 57-67	Pin Groove
4	812 00 00-02	E Ring #5133-62
5	819 21 16-21	Washer 21/32 x 1 x 21 Ga.
6	532 12 01-83	Bearing Nylon
7	532 10 94-13	Grip Handle Bicycle
8	532 12 45-26	Button Plunger Black
11	532 13 98-65	Link Asm. Lift L.H.
12	532 13 98-66	Link Asm. Lift R.H.
13	532 12 46-70	Retainer Spring
15	532 17 32-88	Link Front

KEY NO.	PART NO.	DESCRIPTION
16	873 35 08-00	Nut Jam Hex 1/2-13 unc
17	532 17 56-89	Trunion Blk. Zinc
18	873 80 08-00	Nut Lock w/Wsh. 1/2-13 unc
19	532 13 98-68	Arm Suspension Mower
20	532 19 42-09	Retainer Spring
31	532 16 98-65	Bearing, Pvt. Lift.
32	873 54 06-00	Nut Crownlock 3/8-24

NOTE: All component dimensions given in U.S. inches
1 inch = 25.4 mm

REPAIR PARTS

TRACTOR- -MODEL NO. LZ12597RB (96061029700), PRODUCT NO. 960 61 02-97
SEAT ASSEMBLY

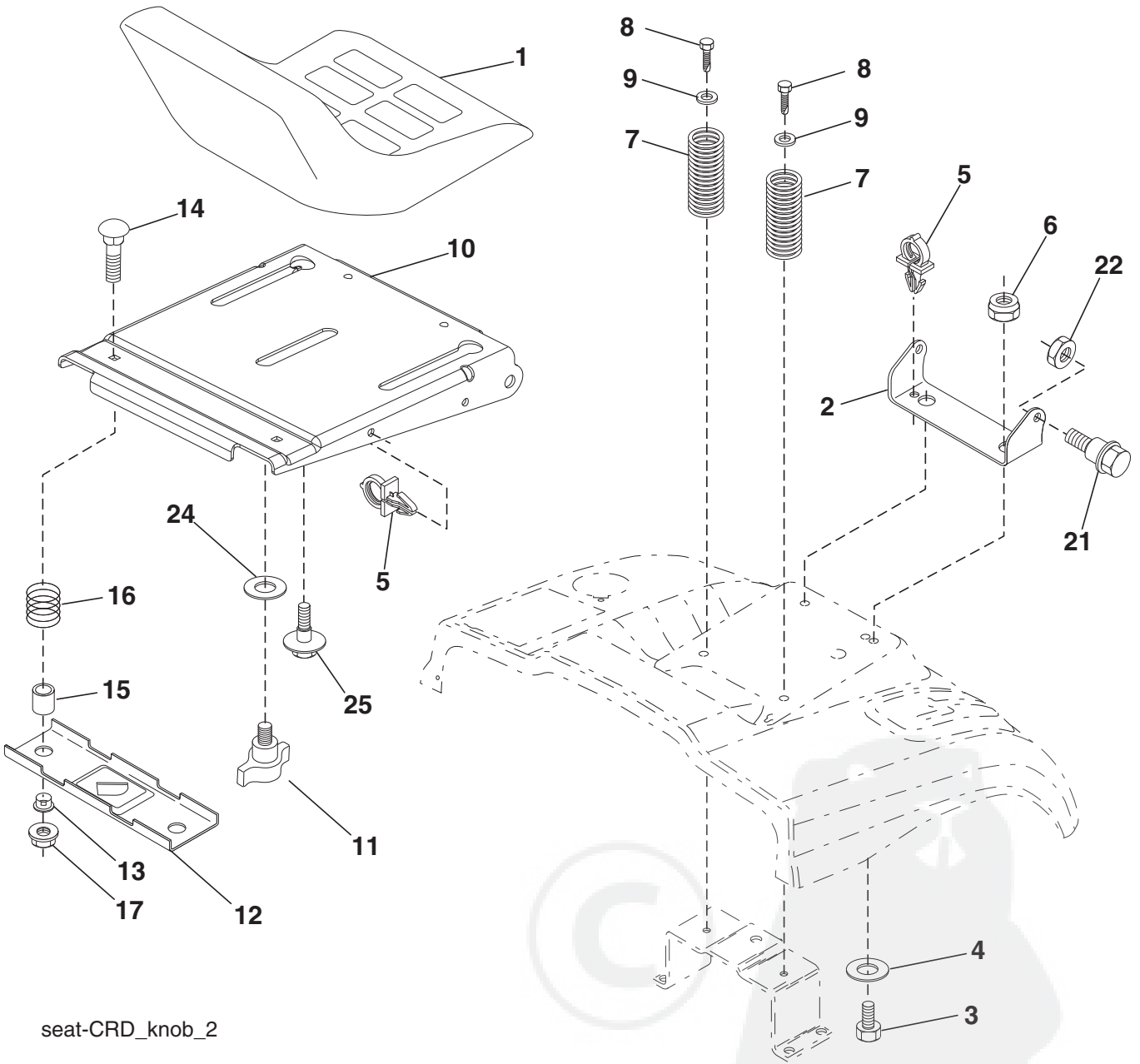

seat-CRD_knob_2

KEY NO.	PART NO.	DESCRIPTION	KEY NO.	PART NO.	DESCRIPTION
1	532 40 10-42	Seat	13	532 12 12-48	Bushing Snap Blk. Nyl. 50 Id
2	532 14 05-51	Bracket Pnt Pivot Seat (blk.)	14	872 05 04-12	Bolt Rdhd. Sht. Nk. 1/4-20 x 1-1/2
3	871 11 06-16	Bolt Fin Hex 3/8-16 unc x 1	15	532 13 43-00	Spacer Split
4	819 13 16-10	Washer Flat 13/32 x 1 x 10 Ga.	16	532 12 12-50	Spring Cprsn. Plate SW 1.3 10 Ga.
5	532 14 50-06	Clip Push In Hinged	17	532 12 39-76	Nut Lock 1/4 Lge. Flg. Gr. 5 Zinc
6	873 80 06-00	Nut Lock Hex 3/8-16 unc	21	532 17 18-52	Bolt Shoulder 5/16-18 unc-2A
7	532 12 41-81	Spring Seat Cprsn. 2 250 Blk. Zi	22	873 80 05-00	Nut Hex Lock w/Ins. 5/16-18
8	817 00 06-16	Screw 3/8-16 x 1-1/2	24	819 17 19-12	Washer 17/32 x 1-3/16 x 12 Ga.
9	819 13 16-14	Washer 13/32 x 1 x 14 Ga.	25	532 12 70-18	Bolt Shoulder 5/16-18 x 62
10	532 19 55-30	Pan Pnt. Seat (blk.)			
11	532 16 63-69	Knob Seat			
12	532 17 46-48	Bracket Pnt. Mounting Switch			

NOTE: All component dimensions given in U.S. inches.
1 inch = 25.4 mm

REPAIR PARTS

TRACTOR- -MODEL NO. LZ12597RB (96061029700), PRODUCT NO. 960 61 02-97
DECALS

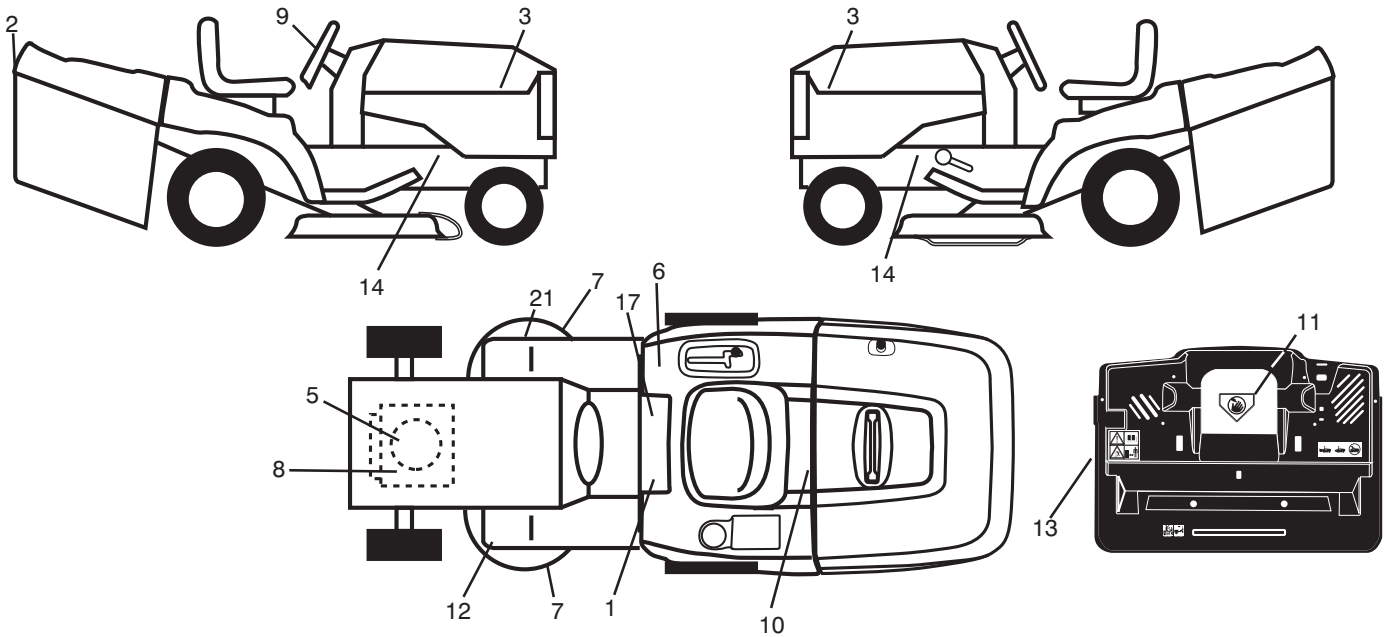

KEY NO.	PART NO.	DESCRIPTION	KEY NO.	PART NO.	DESCRIPTION
1	532 40 03-89	Decal, Warning Syms. CE	13	532 14 08-35	Decal, Backplate
2	532 43 35-13	Decal, Fender	12	532 15 97-37	Decal, Brake/Clutch Symbol Lt.
3	532 43 34-63	Decal, Hood RH/LH	14	532 15 97-36	Decal, Chassis Hot Muffler
5	532 19 68-41	Decal, Warning Eng. Symbols	17	532 14 08-37	Decal, Saddle Brake Parking
6	532 18 04-32	Decal, Fender 100 OB/CE	21	532 16 62-86	Decal, Hex Belt Sch. 92 CRD
8	532 41 79-26	Decal, Engine HP	--	532 13 83-11	Decal, Lift Handle
9	532 43 36-55	Decal, Strg. Whl.	--	532 43 13-20	Manual Operator's (Euro)
10	532 14 50-05	Decal, Bat. Dan./Poi. P/L Sym. Wprn.	--	532 43 32-19	Manual Parts
11	532 18 21-66	Decal, Mower Cut Finger Symbol			

WHEELS & TIRES

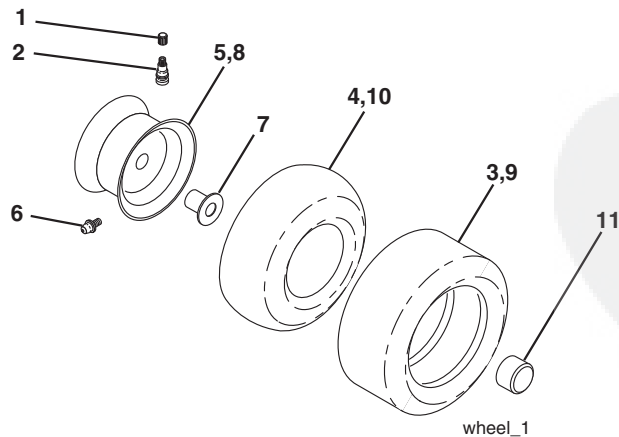

KEY NO.	PART NO.	DESCRIPTION
1	532 05 91-92	Cap Valve Tire
2	532 06 51-39	Stem Valve
3	532 10 62-22	Tire F Ts 15 x 6 0 - 6
4	532 05 99-04	Tube Inner Front #35060
5	532 18 33-37	Rim Asm. 6" Front
6	532 12 49-57	Fitting Grease
7	532 12 49-59	Bearing Flange
8	532 18 33-38	Rim Asm. 8" Rear
9	532 42 05-31	Tire R Ts 18 x 9.5-8 Turf Saver LT
10	532 12 49-26	Tube Rear 9 5 x 8
11	532 17 50-39	Cap Axle Blk. 1 50 x 1 00
--	532 14 43-34	Sealant, Tire (10 oz. tube)

NOTE: All component dimensions given in U.S. inches
1 inch = 25.4 mm

REPAIR PARTS

TRACTOR- -MODEL NO. LZ12597RB (96061029700), PRODUCT NO. 960 61 02-97
BAGGER

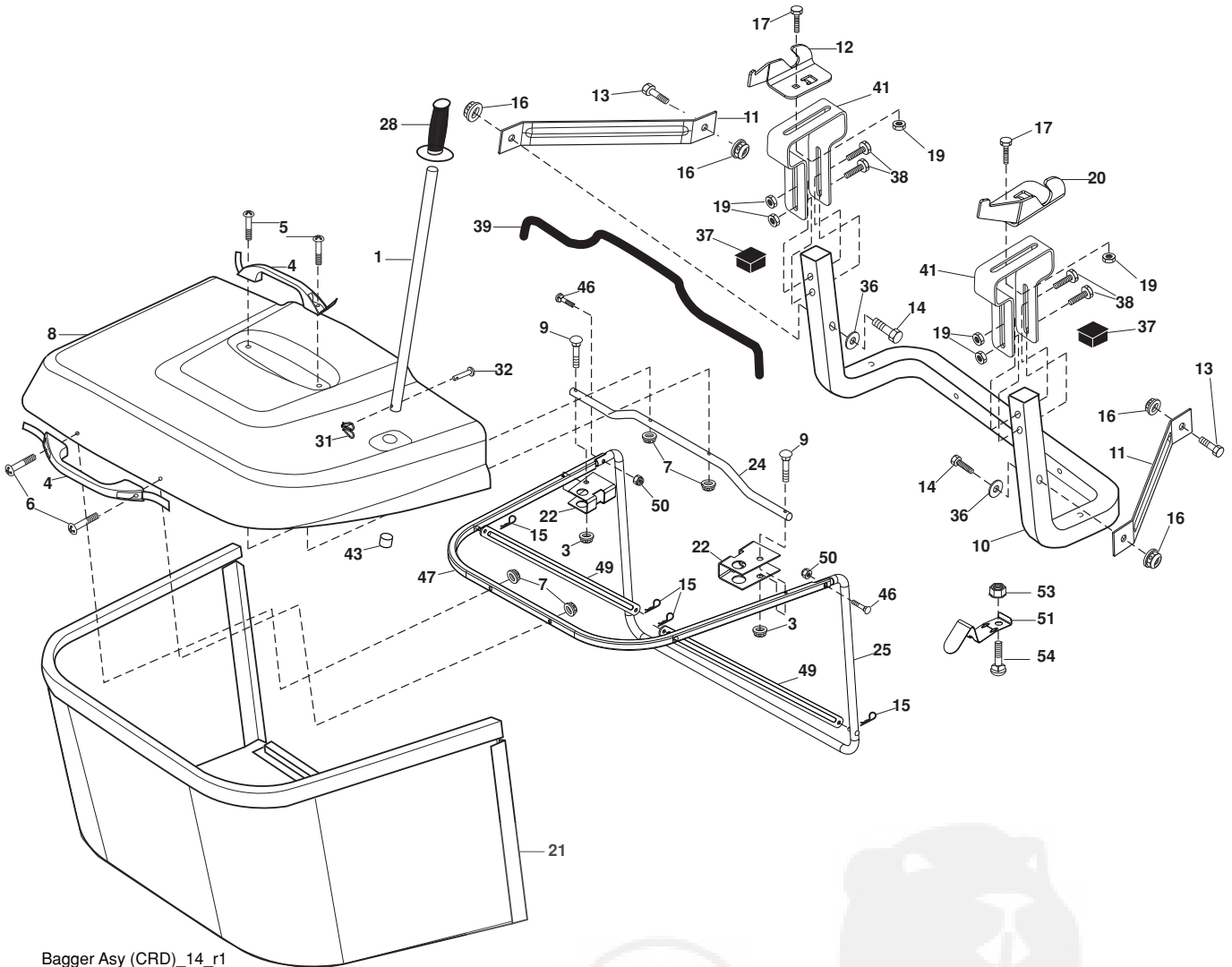

Bagger Asy (CRD)_14_r1

KEY NO.	PART NO.	DESCRIPTION	KEY NO.	PART NO.	DESCRIPTION
1	532 42 86-10	Tube Handle Bagger CRD	25	532 19 37-05	Tube Front Bagger CRD
3	532 12 39-76	Nut Lock 1/4 Lge. Flg. Gr. 5 Zinc	28	532 16 57-87	Grip Handle Black
4	532 16 99-16	Handle Bagger w/Lvrs. Gr. 5 Zinc	31	532 16 94-84	Retainer Clip
5	874 98 10-24	Screw Pan Head #10-24 x 1.50 Blk.	32	532 12 68-75	Rivet Rd. Hd. Drilled 3/8 Dia.
6	874 98 10-32	Screw Pan Head	36	819 13 20-12	Washer 13/32 x 1-1/4 x 12 Ga.
7	873 40 10-00	Nut Wiz Lock Hex Serr/Hd. #10-24	37	532 17 54-01	Plug Support Bagger CRD
8	532 18 13-54	Cover Bagger Steel	38	872 01 05-20	Bolt 5/16-18 x 2-1/2
9	872 14 04-18	Bolt Carriage 1/4-20 x 2.25d x Gr. 5	39	532 41 62-57	Seal Trim 37"
10	532 18 12-82	Tube Support Bagger CRD	41	532 43 27-55	Bracket Bagger CRD
11	532 16 57-19	Bracket Support Upper Bag CRD	43	532 17 40-83	Plug Tubing End
12	532 18 88-48	Bracket Pivot LH	46	872 11 05-10	Bolt Carr. 5/16-18 x 1-1/4 Gr. 5
13	874 76 06-12	Bolt Hex 3/8-16 unc x 3/4	47	532 19 37-05	Tube Upper Bagger
14	874 52 06-36	Bolt Fin Hex 3/8-16 x 2-1/4 Gr. 5	49	532 19 33-05	Spreader Bar Bagger
15	532 12 46-70	Retainer Spring	50	873 80 05-00	Nut Lock Hex W/Insert 5/16-18 unc
16	873 90 06-00	Nut Latch Flg. 3/8-16 unc	51	532 19 99-03	Latch Spring
17	872 14 05-06	Bolt Rdhd. Sht. Sqnk. 5/16-18uncx3/4	53	873 51 04-00	Nut Keps Hex 1/4-20 unc
19	873 90 05-00	Nut Lock Hex Flange 5/16-18	54	872 14 04-06	Bolt Rdhd. Sqnk. 1/4-20 x 3/4 Gr. 5
20	532 18 88-47	Bracket Pivot RH			
21	532 40 61-80	Bag Asm. CRD			
22	532 16 57-81	Bracket Side Bagger CRD			
24	532 16 57-83	Tube Pivot Bagger CRD			

NOTE: All component dimensions given in U.S. inches
1 inch = 25.4 mm

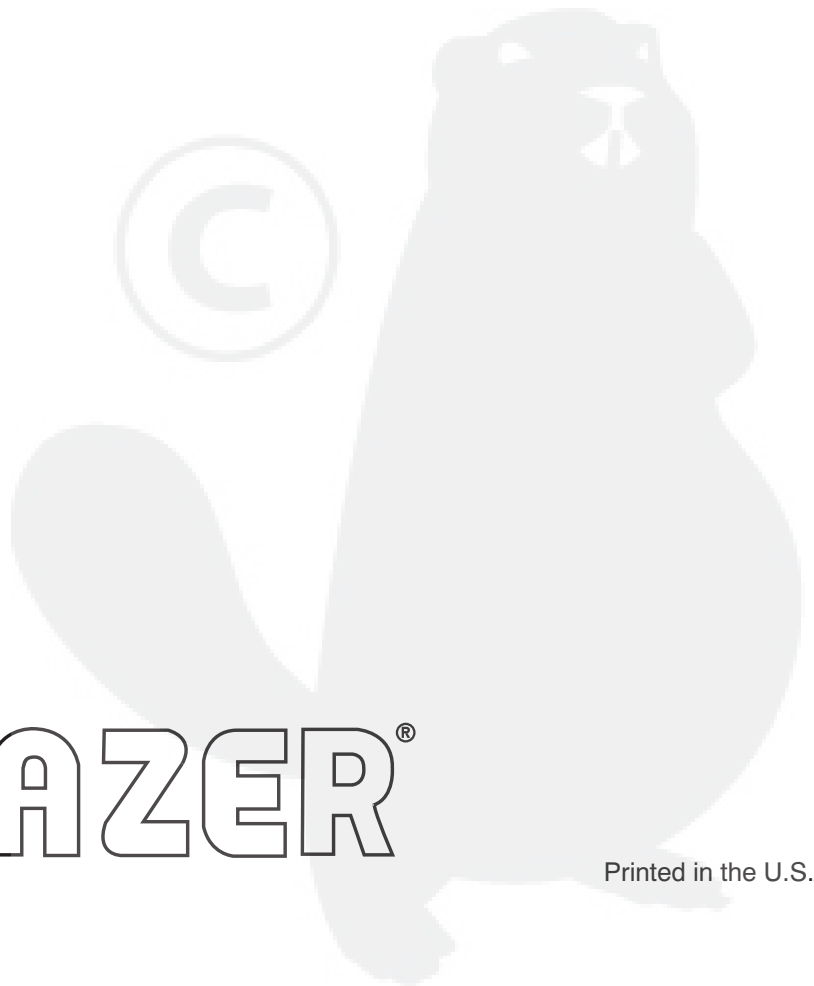
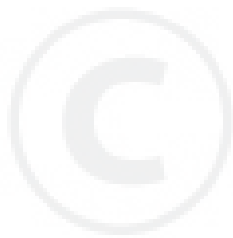

LAZER[®]