

**REPAIR PARTS MANUAL**  
**MODEL NO. PF135B97 (96011025701)**  
**Lawn Tractor**



**PERFORMANCE**  
**POWER** 

# HOW TO USE THIS MANUAL

This manual is designed to provide the customer with a means to identify the parts on his/her tractor when ordering repair parts. The illustrations may or may not represent the actual assemblies; therefore, it is not recommended to use this manual as a guide to assemble or disassemble the tractor. Some hardware and parts are drawn larger in order to more readily identify them.

Each tractor has its own model number.

The model number for your tractor can be found on the fender under the seat.

When ordering parts, always give the following information:

- Product - "Lawn Tractor"
- Model Number - PF135B97 (96011025701)
- Part Number
- Part Description

## TABLE OF CONTENTS

<b>SCHEMATIC .....</b>	<b>3</b>
<b>ELECTRICAL.....</b>	<b>4-5</b>
<b>CHASSIS AND ENCLOSURES.....</b>	<b>6-7</b>
<b>DRIVE.....</b>	<b>8-9</b>
<b>STEERING WHEEL .....</b>	<b>10-11</b>
<b>ENGINE.....</b>	<b>12-13</b>
<b>SEAT ASSEMBLY.....</b>	<b>14</b>
<b>MOWER LIFT.....</b>	<b>15</b>
<b>MOWER DECK .....</b>	<b>16-17</b>
<b>DECALS.....</b>	<b>18</b>

# TRACTOR-MODEL NUMBER PF135B97 (96011025701), PRODUCT NO. 960 11 02-57 SCHEMATIC

SCH03

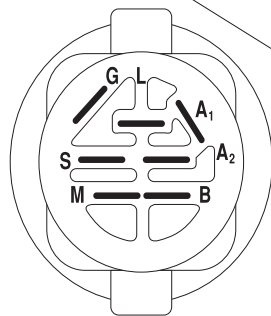
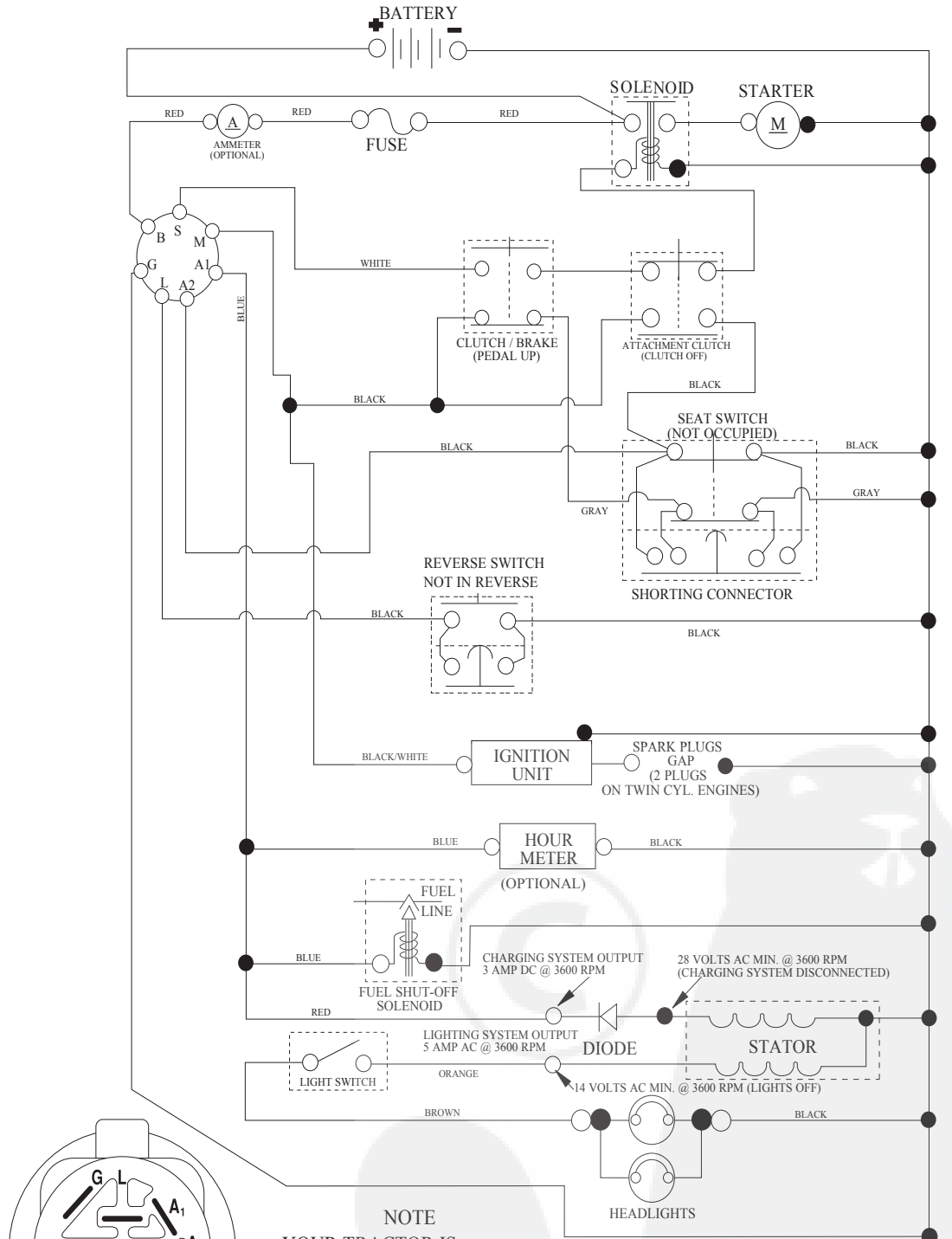

IGNITION SWITCH

POSITION	CIRCUIT "MAKE"
OFF	M+G+A1
RUN/OVERRIDE	B+A1
RUN	B+A1 L+A2
START	B+S+A1

## NOTE

YOUR TRACTOR IS EQUIPPED WITH A SPECIAL ALTERNATOR SYSTEM. THE LIGHTS ARE NOT CONNECTED TO THE BATTERY, BUT HAVE THEIR OWN ELECTRICAL SOURCE. BECAUSE OF THIS, THE BRIGHTNESS OF THE LIGHTS WILL CHANGE WITH ENGINE SPEED. AT IDLE THE LIGHTS WILL DIM. AS THE ENGINE IS SPEEDED UP, THE LIGHTS WILL BECOME THEIR BRIGHTEST.

●  
NON-REMOVABLE CONNECTIONS

○  
REMOVABLE CONNECTIONS

WIRING INSULATED CLIPS  
NOTE: IF WIRING INSULATED CLIPS WERE REMOVED FOR SERVICING OF UNIT, THEY SHOULD BE RE-INSTALLED TO PROPERLY SECURE YOUR WIRING.

# REPAIR PARTS

TRACTOR-MODEL NUMBER PF135B97 (96011025701), PRODUCT NO. 960 11 02-57

## ELECTRICAL

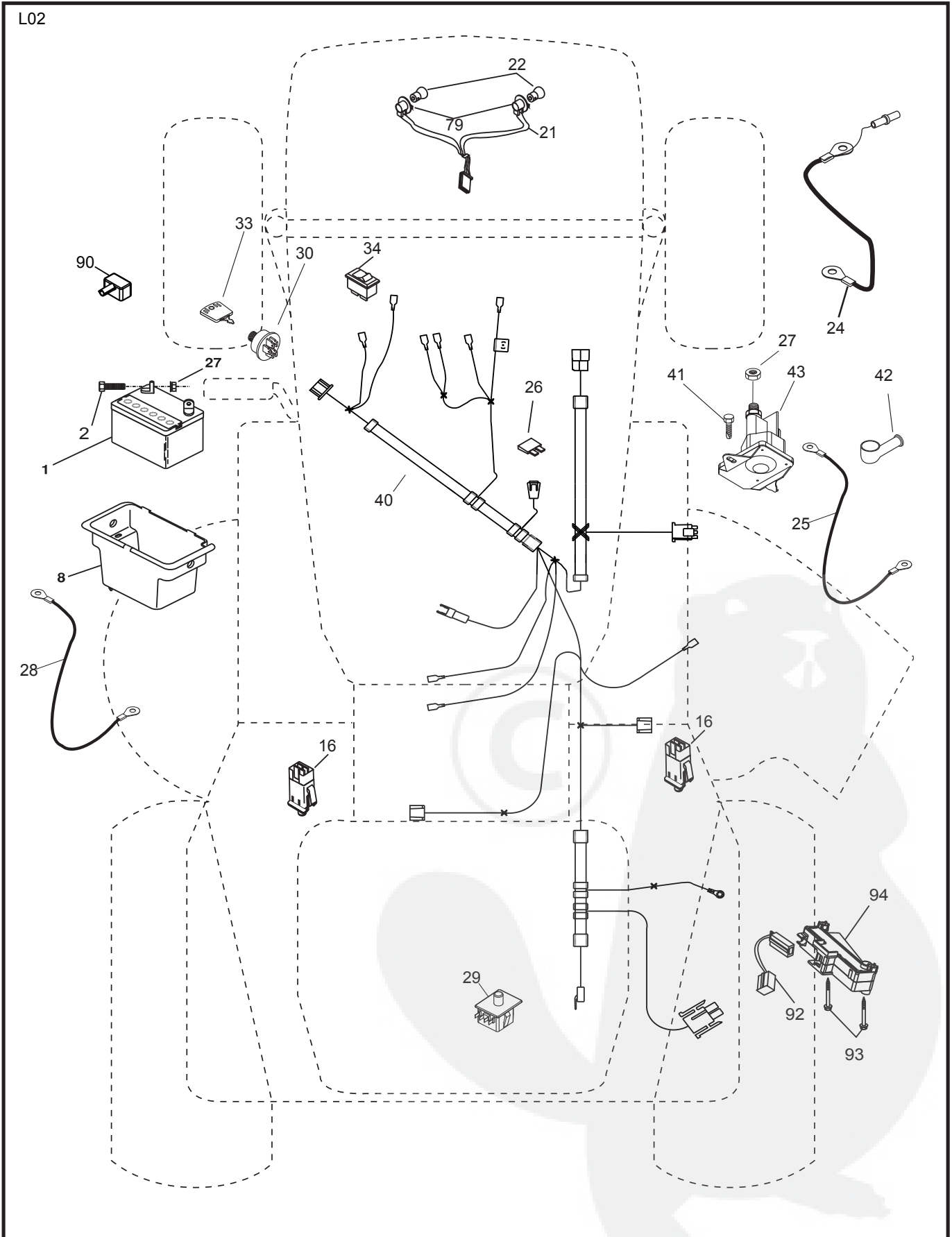

# REPAIR PARTS

TRACTOR-MODEL NUMBER PF135B97 (96011025701), PRODUCT NO. 960 11 02-57  
ELECTRICAL

KEY NO.	PART NO.	DESCRIPTION
1	532 16 34-65	Battery 12 Volt 25 Amp
2	874 76 04-12	Bolt Hex Hd. 1/4-20 unc x 3/4
8	532 17 66-89	Battery Box
16	532 17 61-38	Switch Interlock Push-In
21	532 18 37-59	Harness Asm. Light w/4152J
22	532 00 41-52	Bulb
24	532 12 47-80	Cable Battery 6 Ga. 11" Red
25	532 14 61-47	Cable Battery
26	532 17 51-58	Fuse
27	873 51 04-00	Nut Keps Hex 1/4-20 unc
28	532 12 47-73	Cable Ground 6 Ga. 12" Black
29	532 19 27-49	Switch Seat
30	532 19 33-50	Switch Ign.
33	<b>532 41 19-35</b>	Key/Chain
34	532 11 07-12	Switch Light
40	532 19 74-28	Harness Ign.
41	871 11 04-08	Bolt Blk. Fin. Hex 1/4-20
42	532 13 15-63	Cover Terminal Red
43	532 19 25-07	Solenoid
79	<b>532 17 52-42</b>	Socket Asm. Bulb Twistlock
90	532 18 04-49	Cover Terminal Battery
92	532 19 66-15	Harness Pigtail Consle ROS
93	532 19 25-40	Screw Plastite 10-14 x 2.0
94	532 19 18-34	Module Reverse ROS

**NOTE:** All component dimensions given in U. S. inches  
1 inch = 25.4 mm.

# REPAIR PARTS

TRACTOR-MODEL NUMBER PF135B97 (96011025701), PRODUCT NO. 960 11 02-57  
CHASSIS AND ENCLOSURES

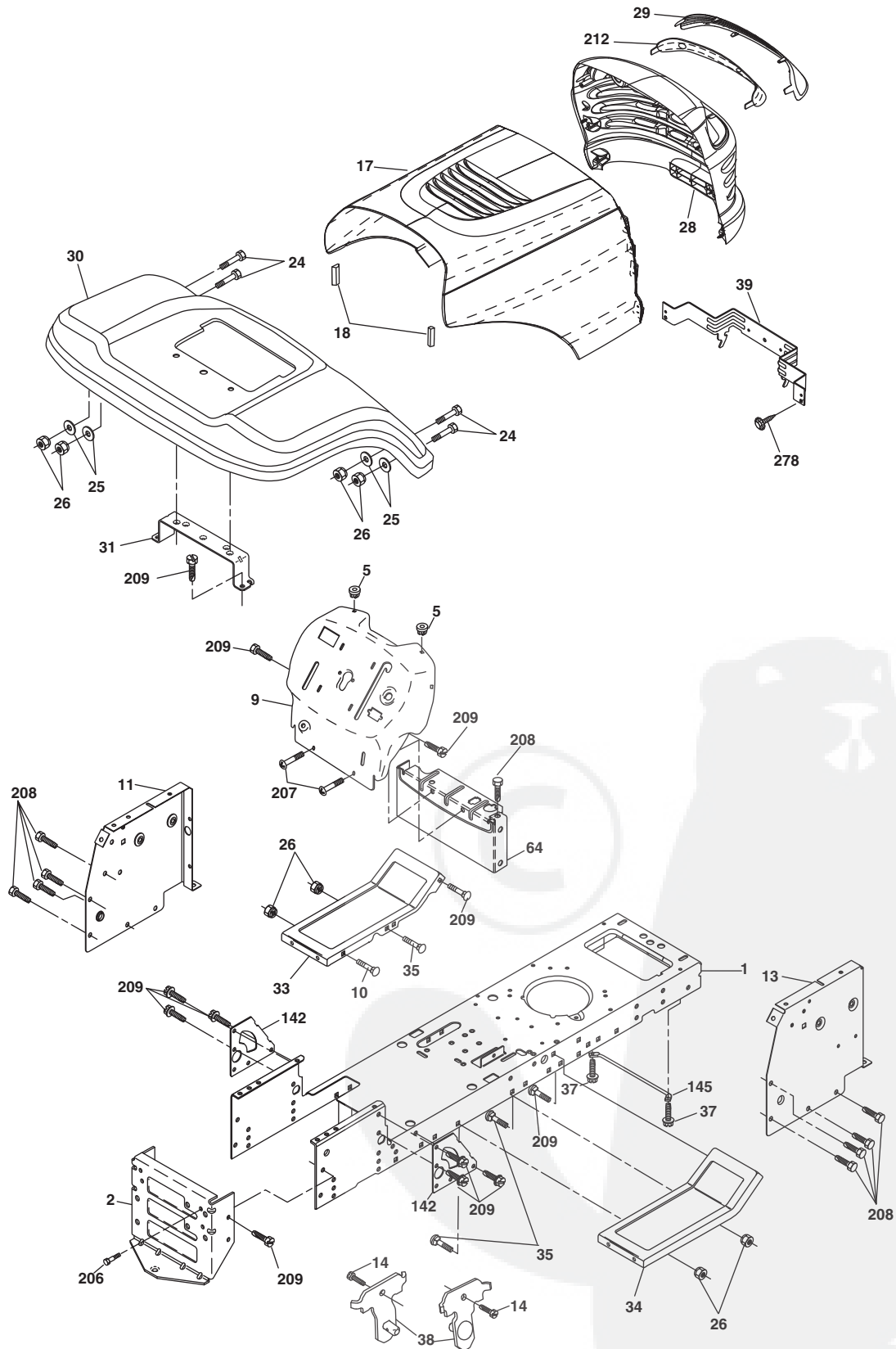

chassis-stlt\_elite value\_2

# REPAIR PARTS

TRACTOR-MODEL NUMBER PF135B97 (96011025701), PRODUCT NO. 960 11 02-57  
CHASSIS AND ENCLOSURES

KEY NO.	PART NO.	DESCRIPTION
1	532 17 46-19	Chassis
2	532 17 65-54	Drawbar
5	532 15 52-72	Bumper, Hood/Dash
9	532 19 48-22	Dash
10	872 14 06-08	Bolt 3/8-16 x 1
11	532 17 49-96	Panel Dash LH
13	532 18 69-52	Panel Silkscr. Dash RH
14	817 49 06-08	Screw 3/8-16 x 1/2
17	532 40 73-70	Hood
18	532 18 49-21	Bumper Hood
24	874 78 06-16	Bolt Fin. Hex 3/8-16 unc x 1 Gr. 5
25	819 13 13-12	Washer 13/32 x 13/16 x 12 Ga.
26	873 80 06-00	Nut Lock Hex w/Ins. 3/8-16 unc
28	532 18 35-52	Grille Asm.
29	532 18 58-46	Lens Grille
30	532 40 34-09	Fender
31	532 13 66-19	Bracket Fender Repl. 109873x
33	532 40 34-11	Footrest Pnt. LH
34	532 40 34-10	Footrest Pnt. RH
35	872 11 06-06	Bolt Rdhd. Sht. Sqnk. 3/8-16 x 3/4
37	817 49 05-08	Screw Thdrol. 5/16-18 x 1/2 TYT
38	532 17 57-10	Bracket Asm. Pivot Mower Rear
39	532 40 78-07	Bracket Pivot
64	532 15 47-98	Dash Lower
142	532 17 57-02	Plate Reinforcement
145	<b>532 40 91-67</b>	Rod Pivot Chassis/Hood
206	532 17 01-65	Bolt Shoulder 5/16-18
207	817 06 05-08	Screw 5/16-18 x 1/2
208	817 67 06-08	Screw Thdrol. 3/8-16 x 1/2
209	817 00 06-12	Screw Hex Wsh. Thdrol. 3/8-16
212	532 18 35-50	Insert Lens
278	<b>532 41 63-58</b>	Screw #10 x 0.075 BOS Thread
--	532 00 54-79	Plug Button Blk. 359 Dia. Choke

**NOTE:** All component dimensions given in U.S. inches  
1 inch = 25.4 mm.

# REPAIR PARTS

TRACTOR-MODEL NUMBER PF135B97 (96011025701), PRODUCT NO. 960 11 02-57  
DRIVE

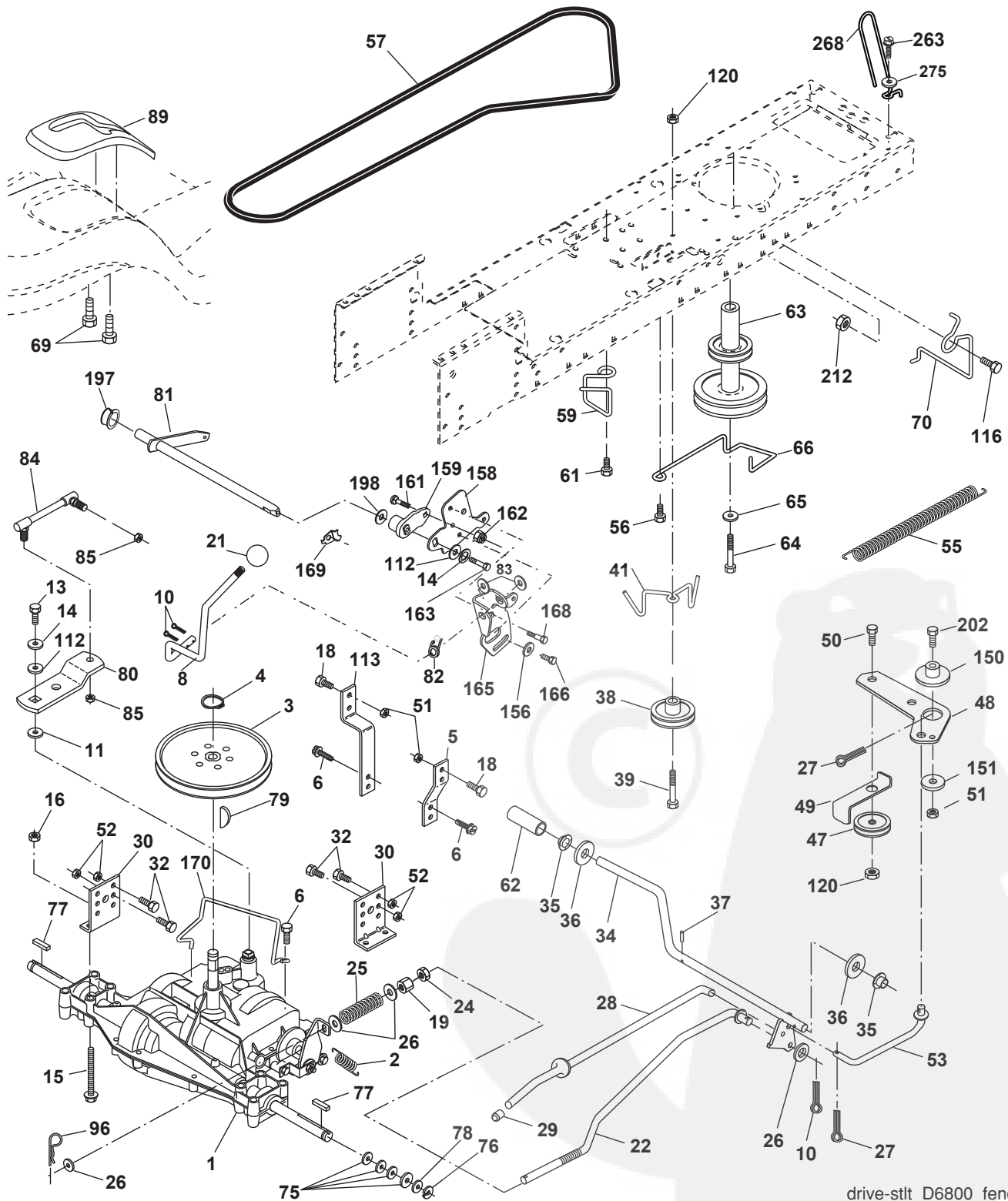

drive-stlt\_D6800\_fender\_3\_r1



# REPAIR PARTS

TRACTOR-MODEL NUMBER PF135B97 (96011025701), PRODUCT NO. 960 11 02-57  
DRIVE

KEY NO.	PART NO.	DESCRIPTION	KEY NO.	PART NO.	DESCRIPTION
1	-----	Transaxle, DANA D6800-2	66	532 15 47-78	Keeper Belt Engine Fire Proof
2	532 14 66-82	Spring Return Brake T/A Zinc	69	532 14 24-32	Screw Hex Wsh. Hi-Lo 1/4 x 1/2 unc
3	532 12 36-66	Pulley Transaxle 18" Tires	70	532 13 46-83	Guide Belt Mower Drive RH
4	812 00 00-28	Ring Retainer # 5100-62	75	532 12 17-49	Washer 25/32 x 1 1/4 x 16 Ga.
5	532 12 15-20	Strap Torque 30 Degrees	76	812 00 00-01	E-Ring #5133-75
6	817 06 05-12	Screw 5/16-18 x 3/4	77	532 12 35-83	Key Square 2 0 x 1845/ 1865
8	532 19 27-06	Rod Shifter	78	532 12 17-48	Washer 25/32 x 1-5/8 x 16 Ga.
10	876 02 04-16	Pin Cotter 1/8 x 1 Cad	79	532 12 50-96	Key Woodruff
11	532 10 57-01	Washer Plate Shf. 388 Sq. Hole	80	532 13 14-88	Arm Shift Transaxle
13	874 55 04-12	Bolt 1/4-28 unf Gr. 8 w/Patch	81	532 16 55-94	Shaft Asm. Cross Taper
14	810 04 04-00	Washer Lock Hvy. Helical 1/4	82	532 16 57-11	Spring Torsion Shift
15	874 49 05-44	Bolt Hex Flghd. 5/16-18 Gr. 5	83	819 17 12-16	Washer 17/32 x 3/4 x 16 Ga.
16	873 80 05-00	Nut Lock Hx. w/Ins. 5/16-18 unc	84	532 16 62-29	Link Transaxle
18	874 78 06-16	Bolt, Fin. Hex 3/8-16 unc x 1 Gr. 5	85	532 15 03-60	Nut Lock Center 1/4-28
19	873 80 06-00	Nut Lock 3/8-16 unc	89	532 19 49-71	Console SVC Shift
21	532 10 69-33	Knob	96	532 12 47-88	Retainer Spring 1"
22	532 13 08-04	Rod Brake Blk. Zinc 26 840	112	819 09 12-10	Washer 9/32 x 3/4 x 10 Ga.
24	873 35 06-00	Nut Hex Jam 3/8-16 unc	113	532 12 72-85	Strap Torque LH
25	532 10 68-88	Spring Rod Brake 2 00 Zinc	116	872 14 06-08	Bolt Rdhd. Sqnk. 3/8-16 x 1.00
26	819 13 13-16	Washer 13/32 x 13/16 x 16 Ga.	120	873 90 06-00	Nut Lock Flg. 3/8-16
27	876 02 04-12	Pin Cotter 1/8 x 3/4 Cad.	150	532 17 54-56	Spacer Retainer
28	532 17 57-65	Rod Brake Parking	151	819 13 32-10	Washer 13/32 x 2 x 10
29	532 07 16-73	Cap Brake Parking	156	532 16 60-02	Washer Srtd. 5/16 ID x 1.0 x .125TK
30	532 17 49-73	Bracket Mtg. Transaxle	158	532 16 55-89	Bracket Shift Mount
32	874 76 05-12	Bolt Hex Hd. 5/16-18 unc x 3/4	159	532 18 39-00	Hub Shift
34	532 17 55-78	Shaft Asm. Pedal Foot	161	872 14 04-06	Bolt Rdhd. Sqnk. 1/4-20 x 3/4 Gr. 5
35	532 12 01-83	Bearing Nylon Blk. 629 Id.	162	873 68 04-00	Nut Crownlock 1/4-20 unc
36	819 21 16-16	Washer 21/32 x 1 x 16 Ga.	163	874 78 04-16	Bolt Hex Fin. 1/4-20 unc x 1 Gr. 5
37	532 12 49-63	Pin Roll 3/16 x 1"	165	532 16 56-23	Bracket Pivot Lever
38	532 17 91-14	Pulley Idler Composite	166	817 49 05-10	Screw 5/16-18 x 5/8 TT Yellow
39	872 11 06-22	Bolt Rdhd. 3/8-16 unc x 2-3/4 Gr. 5	168	532 16 54-92	Shoulder Bolt 5/16 -18 x .561
41	532 17 55-56	Keeper Belt Retainer Idler	169	532 16 55-80	Plate Fastening
47	532 12 77-83	Pulley Idler V Groove Plastic	170	532 18 74-14	Keeper Belt T/A
48	532 15 44-07	Bellcrank Asm.	197	532 16 96-13	Nyliner Snap-In 5/8" ID
49	532 12 32-05	Retainer Belt Style Spring	198	532 16 95-93	Washer Nylon
50	872 11 06-12	Bolt Carr. Sh. 3/8-16 x 1-1/2 Gr. 5	202	872 11 06-14	Bolt, 3/8 - 16 x 1-3/4 Gr. 5
51	873 68 06-00	Nut Crownlock 3/8-16 unc	212	532 14 52-12	Nut Flange Hex Lock
52	873 68 05-00	Nut Crownlock 5/16-18 unc	263	817 00 06-12	Screw 3/8-16 x 3/4
53	532 19 96-52	Link Clutch	268	532 18 24-02	Guard Muffler
55	532 10 57-09	Spring Return Clutch 6 75	275	819 13 16-14	Washer 13/32 x 1 x 14 Ga.
56	817 06 06-20	Screw 3/8-16 x 1-1/4			
57	532 40 16-03	V-Belt Ground Drive			
59	532 16 96-91	Keeper Belt Span Ctr.			
61	817 12 06-14	Screw 3/8-16 x .875			
62	532 12 48-72	Cover Pedal Blk. Round			
63	532 17 54-10	Engine Pulley			
64	532 17 39-37	Bolt Hex			
65	810 04 07-00	Washer Lock Hvy. Hlcl. Spr. 7/16			

**NOTE:** All component dimensions given in U.S. inches  
1 inch = 25.4 mm

# REPAIR PARTS

TRACTOR-MODEL NUMBER PF135B97 (96011025701), PRODUCT NO. 960 11 02-57

## STEERING

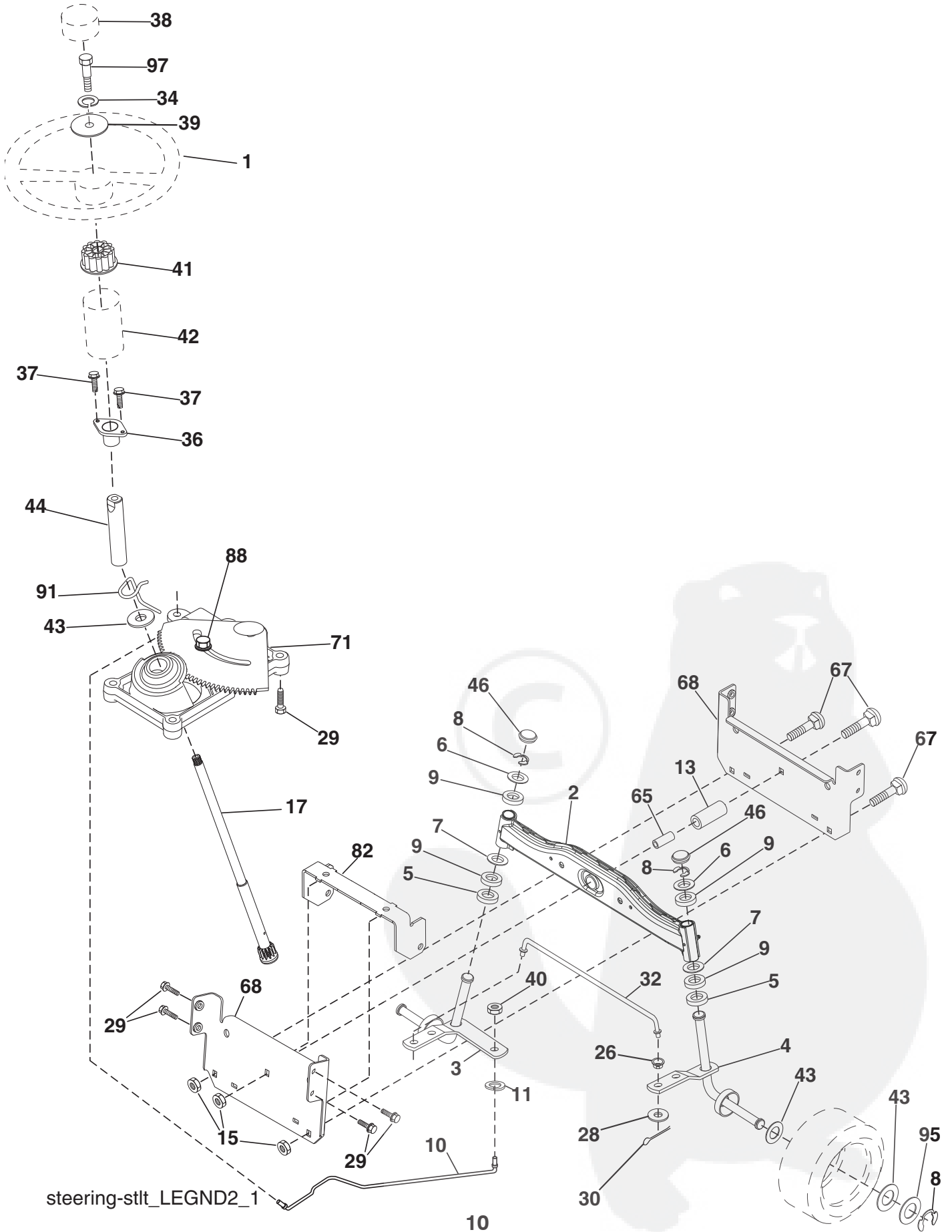

# REPAIR PARTS

TRACTOR-MODEL NUMBER PF135B97 (96011025701), PRODUCT NO. 960 11 02-57  
STEERING

KEY NO.	PART NO.	DESCRIPTION
1	532 19 45-95	Wheel Steering
2	532 19 56-73	Axle Asm.
3	532 16 98-40	Spindle Asm. LH
4	532 16 98-39	Spindle Asm. RH
5	532 12 49-31	Bearing Race Thrust Harden
6	532 12 17-48	Washer 25/32 x 1-5/8 x 16 Ga.
7	819 27 20-16	Washer 27/32 x 1-1/4 x 16 Ga.
8	812 00 00-29	Ring Clip #T5304-75
9	532 12 49-37	Bearing Col. Strg. Blk.
10	532 17 51-21	Link Drag
11	810 04 06-00	Washer Lock Hvy. Hlcl. Spr. 3/8
13	532 13 65-18	Spacer Bearing Axle Front
15	532 14 52-12	Hex Flange Lock
17	532 19 07-53	Shaft Asm. Strg.
26	532 12 68-47	Bushing Link Drag. Blk. LR
28	819 13 14-16	Washer 13/32 x 7/8 x 16 Ga.
29	817 00 06-12	Screw 3/8-16 x 3/4
30	876 02 04-12	Pin Cotter 1/8 x 3/4 Cad.
32	532 19 27-57	Rod Tie Wire Form 19 75 Mech.
34	810 04 05-00	Washer Lock 5/16
36	532 15 50-99	Bushing Strg. 5/8 Id. Dash
37	532 15 29-27	Screw
38	532 19 46-03	Cap Wheel Steering
39	819 11 38-12	Washer 11/32 ID x 2 3/8 OD x 12 Ga.
40	873 54 06-00	Nut Crownlock 3/8-24
41	532 18 67-37	Adapter Wheel Strg.
42	532 16 96-33	Boot Steering
43	532 12 17-49	Washer 25/32 x 1 1/4 x 16 Ga.
44	532 19 07-52	Extension Steering
46	532 12 12-32	Cap Spindle Fr. Top Blk.
65	<b>532 41 47-36</b>	Spacer Brace Axle
67	872 11 06-18	Bolt Rdhd. Sqnk. 3/8-16 x 2-1/4
68	532 16 98-27	Brace Axle
71	532 17 51-46	Steering Asm.
82	532 19 99-78	Bracket Susp. Chassis Front
88	532 17 51-18	Bolt Shoulder 7/16-20
91	532 17 55-53	Clip Steering
95	532 18 89-67	Washer Hardened
97	874 78 05-64	Bolt 5/16-18 unc x 4" L Gr. 5

**NOTE:** All component dimensions given in U.S. inches  
1 inch = 25.4 mm.

# REPAIR PARTS

TRACTOR-MODEL NUMBER PF135B97 (96011025701), PRODUCT NO. 960 11 02-57  
ENGINE

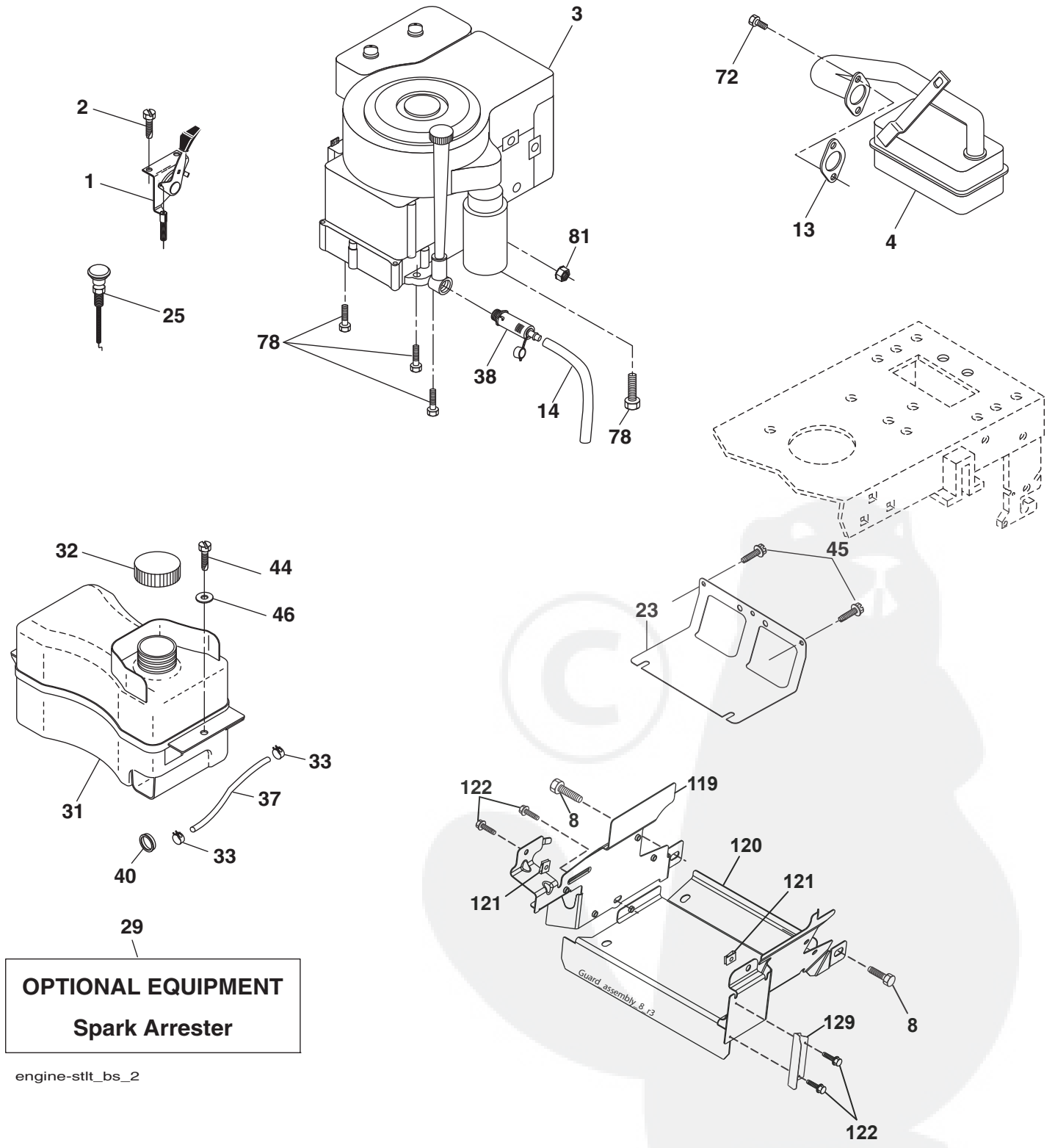

**OPTIONAL EQUIPMENT**  
**Spark Arrester**

engine-stlt\_bs\_2

# REPAIR PARTS

TRACTOR-MODEL NUMBER PF135B97 (96011025701), PRODUCT NO. 960 11 02-57  
ENGINE

KEY NO.	PART NO.	DESCRIPTION
1	532 17 05-51	Control Throttle/Choke
2	817 72 04-08	Screw Hex Thd. Cut 1/4-20 x 5/8 T
3	-----	Engine Briggs Model 21B807
4	532 17 97-58	Muffler Exhaust
8	532 17 18-77	Bolt 5/16-18 unc x 3/4 w/Sems. Blk.
13	532 16 52-91	Gasket
14	532 14 84-56	Tube Drain Oil Easy
23	532 16 98-37	Shield Browning/Debris Guard
25	532 19 06-95	Choke Control
29	532 13 71-80	Arrester Spark
31	532 40 75-16	Tank Fuel
32	532 19 77-25	Cap Asm. Fuel Top
33	532 12 34-87	Clamp Hose Blk.
37	532 13 70-40	Line Fuel 20"
38	532 18 16-54	Plug Drain Oil Easy
40	532 12 40-28	Bushing Snap
44	817 67 04-12	Screw Hex. Wsh. Thdrol. 3/8-16 x 3/4
45	817 00 06-12	Screw 3/8-16 x 3/4
46	819 09 14-16	Washer 9/32 x 7/8 x 16 Ga.
72	532 19 23-34	Screw
78	817 06 06-20	Screw 3/8-16 x 1-1/4
81	873 51 04-00	Nut Keps Hex 1/4-20 unc
119	532 19 79-49	Guard Asm. Eng LH
120	<b>532 19 79-48</b>	Guard Asm. Eng RH
121	532 19 66-88	Clip Threaded
122	532 13 77-29	Screw Thdrol. 1/4-20 x 5/8
129	532 40 03-28	Guard Pulley Eng. Adapter

**NOTE:** All component dimensions given in U.S. inches  
1 inch = 25.4 mm

## Engine Power Rating Information

The gross power rating for individual gas engine models is labeled in accordance with SAE (Society of Automotive Engineers) code J11940 (Small Engine Power & Torque Rating Procedure), and rating performance has been obtained and corrected in accordance with SAE J1995 (Revision 2002-5). Actual gross engine power will be lower and is affected by, among other things, ambient operating conditions and engine-to-engine variability. Given both the wide array of products on which engines are placed and the variety of environmental issues applicable to operating the equipment, the gas engine will not develop the rated gross power when used in a given piece of power equipment (actual "on-site" or net horsepower). This difference is due to a variety of factors including, but not limited to, accessories (air cleaner, exhaust, charging, cooling, carburetor, fuel pump, etc.), application limitations, ambient operating conditions (temperature, humidity, altitude), and engine-to-engine variability. Due to manufacturing and capacity limitations, Briggs & Stratton may substitute an engine of higher rated power for this Series engine.

# REPAIR PARTS

TRACTOR-MODEL NUMBER PF135B97 (96011025701), PRODUCT NO. 960 11 02-57  
SEAT ASSEMBLY

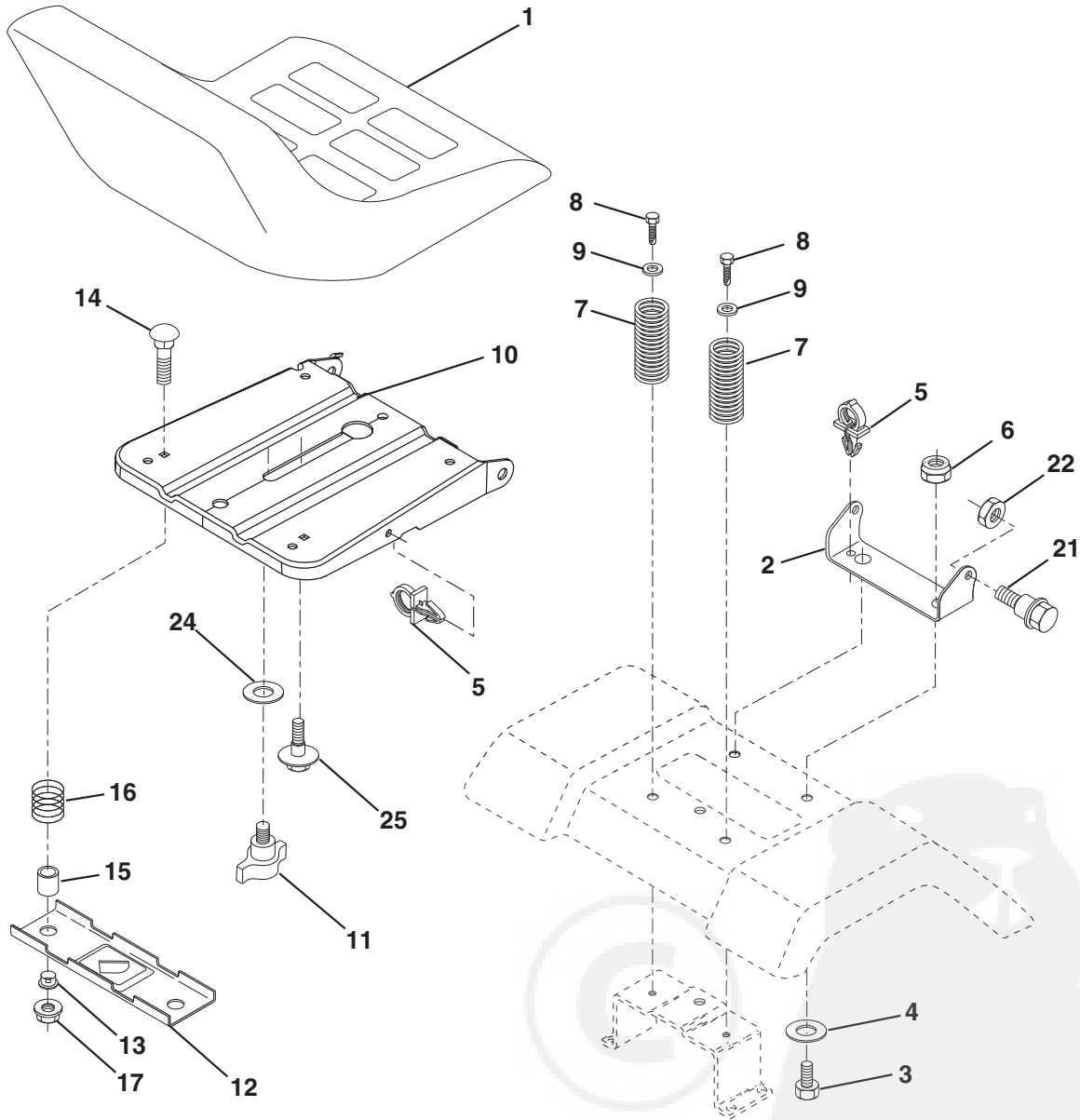

seat-stlt\_knob\_1

KEY NO.	PART NO.	DESCRIPTION
1	532 40 10-42	Seat
2	532 14 05-51	Bracket Seat Pivot
3	871 11 06-16	Bolt Hex 3/8 - 16 x 1
4	819 13 16-10	Washer 13/32 x 1 x 10 Ga.
5	532 14 50-06	Clip Push-In Hinged
6	873 80 06-00	Nut Lock Hex w/Ins. 3/8 - 16
7	532 12 41-81	Spring Seat Cprsn. 2 250 Blk. Zi.
8	817 00 06-16	Screw 3/8-16 x 1.5
9	819 13 16-14	Washer 13/32 x 1 x 14 Ga.
10	532 19 55-30	Pan Pnt. Seat (Blk.)
11	532 16 63-69	Knob Seat
12	532 17 46-48	Bracket Pnt. Mounting Switch

KEY NO.	PART NO.	DESCRIPTION
13	532 12 12-48	Bushing Snap Blk. Nylon
14	872 05 04-12	Bolt Rdhd. Sht. Nk. 1/4 - 20 x 1 -1/2
15	532 13 43-00	Spacer Split .28 x .96
16	532 12 12-50	Spring Cprsn.
17	532 12 39-76	Nut Lock 1/4 Lge. Flg.
21	532 17 18-52	Bolt Shoulder 5/16-18 unc-2A
22	873 80 05-00	Nut Lock Hex w/Ins. 5/16 - 18
24	819 17 19-12	Washer 17/32 x 1-3/16 x 12 Ga.
25	532 12 70-18	Bolt Shoulder 5/16-18 x .62

**NOTE:** All component dimensions given in U.S. inches  
1 inch = 25.4 mm.

# REPAIR PARTS

TRACTOR-MODEL NUMBER PF135B97 (96011025701), PRODUCT NO. 960 11 02-57  
MOWER LIFT

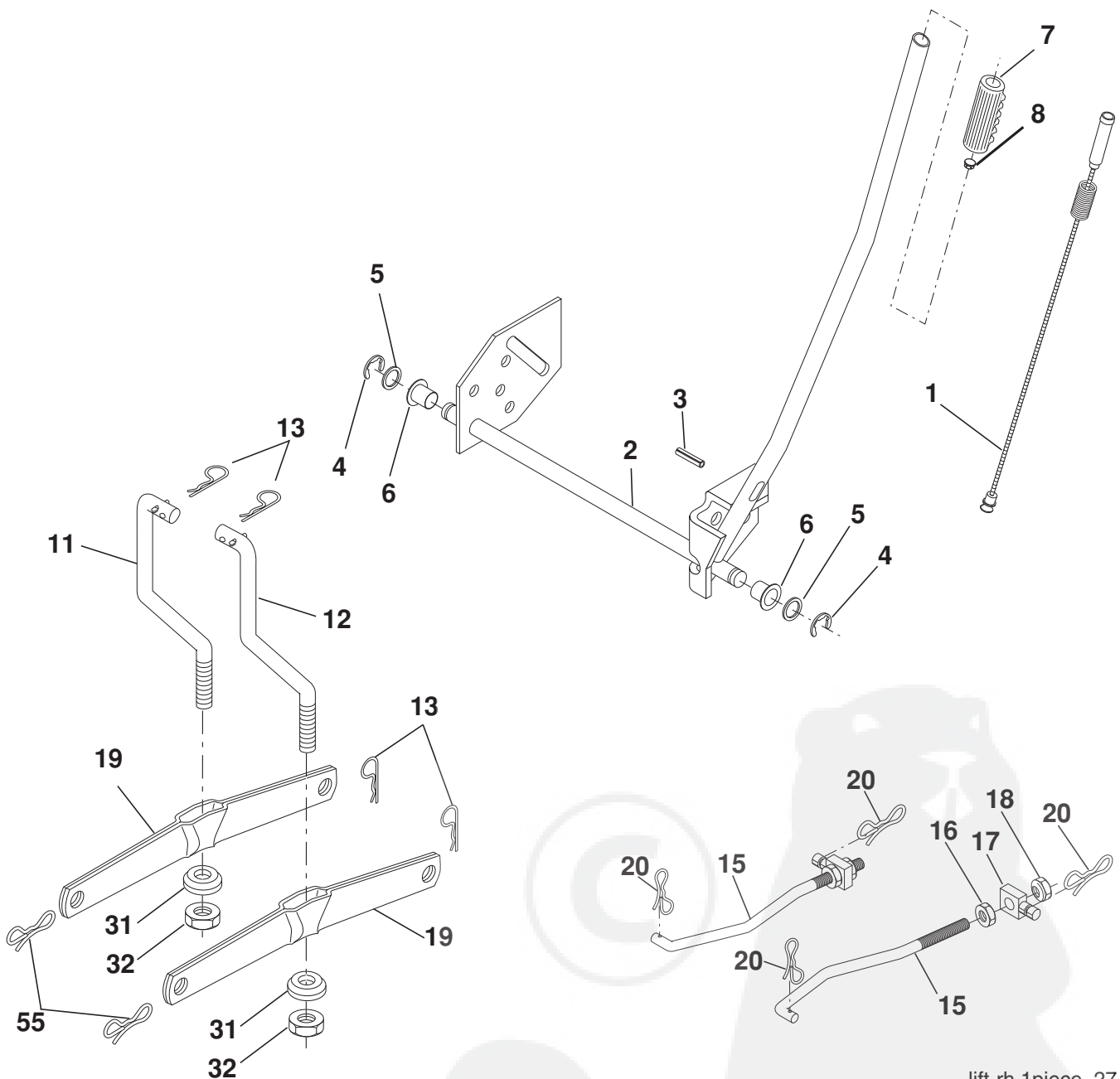

lift-rh.1piece\_27

KEY NO.	PART NO.	DESCRIPTION
1	532 19 84-17	Wire Asm. Inner/Sprg. w/Plunger
2	532 19 80-70	Shaft Asm. Lift RH
3	532 18 88-22	Pin Groove
4	812 00 00-02	E Ring #5133-62
5	819 21 16-21	Washer 21/32 x 1 x 21 Ga.
6	532 12 01-83	Bearing Nylon Blk. 629 Id.
7	532 10 94-13	Grip Handle Bicycle Matte Blk.
8	532 12 45-26	Button Plunger Black
11	532 13 98-65	Link Lift LH Fixed Length
12	532 13 98-66	Link Lift RH Fixed Length
13	532 12 46-70	Retainer Spring

KEY NO.	PART NO.	DESCRIPTION
15	532 17 32-88	Link Front
16	873 35 08-00	Nut Jam Hex 1/2-13 unc
17	532 17 56-89	Trunnion
18	873 80 08-00	Nut Lock w/Wsh. 1/2-13 unc
19	532 13 98-68	Arm Suspension Rear
20	532 19 42-09	Retainer, Spring
31	532 16 98-65	Bearing Pvt. Lift
32	873 54 06-00	Nut Crownlock 3/8-24
55	532 19 24-08	Pin, Cotter 5/16 Bow Tie Lock

**NOTE:** All component dimensions given in U.S. inches  
1 inch = 25.4 mm.





# REPAIR PARTS

TRACTOR-MODEL NUMBER PF135B97 (96011025701), PRODUCT NO. 960 11 02-57  
MOWER DECK

KEY NO.	PART NO.	DESCRIPTION	KEY NO.	PART NO.	DESCRIPTION
1	532 19 25-56	Mower Housing Assembly	122	532 41 01-89	Rod, Brake LH
2	872 14 05-06	Bolt Carriage 5/16-18 x 3/4	123	532 41 01-90	Rod, Brake RH
3	532 13 80-17	Bracket Asm. Fr. Sway Bar	144	532 19 34-14	Keeper Belt Idler Tension
4	532 19 25-68	Bracket Deck Sway Bar 38"/42"	148	532 16 90-22	Spring Return Idler
5	532 12 46-70	Retainer Spring	149	532 16 58-98	Retainer Spring Yellow
6	532 17 80-24	Bar Sway Deck	150	819 09 12-10	Washer 9/32 x 3/4 x 10 Ga.
7	873 80 05-00	Nut Lock Hex w/Ins. 5/16-18 unc	152	532 19 32-35	Clutch Cable 38"/46"
8	532 19 30-03	Bolt 3/8-24 x 1.25 Gr. 8	158	817 72 04-08	Screw Hex Thd. Cut .1/4-20 x 1/2
11	532 19 39-57	Blade Mower	185	532 18 82-34	Head Asm. Cable Clutch
13	532 19 28-72	Shaft Assembly, Mandrel, Vented	186	817 49 06-44	Screw Hex Wsh. Thdrol. 3/8-16 x 2-3/4
14	532 18 72-81	Housing, Mandrel, Vented	187	532 19 34-12	Keeper Belt
15	532 11 04-85	Bearing, Ball, Mandrel	188	532 16 58-91	Bolt Carriage Idler
18	872 14 05-05	Bolt Rdhd. Sqnk. 5/16-18 x 5/8	189	532 19 25-59	Stand, Brake
19	532 13 28-27	Bolt, Shoulder	190	532 19 25-60	Arm, Brake
20	532 40 00-95	Baffle Vortex Front	191	532 19 25-61	Spacer, Brake
21	873 68 05-00	Nut	193	532 19 34-13	Keeper Belt RH Mandrel
23	532 19 25-57	Bracket, Mower Deflector	194	532 19 41-05	Guard Brake
24	532 10 53-04	Cap, Sleeve	195	819 13 32-10	Washer
25	532 19 70-26	Spring, Torsion, Deflector	205	817 49 04-16	Screw 1/4-20 x 1
26	532 11 04-52	Nut, Push	206	819 09 14-16	Washer 9/32 x 7/8 x 16 Ga.
27	532 40 16-18	Shield, Deflector	208	817 67 06-08	Screw 3/8-16 x 1/2
29	532 13 14-91	Rod, Hinge	209	532 40 92-56	Cover Mandrel LH
30	532 17 39-84	Screw Thdrol.	210	532 40 92-57	Cover Mandrel RH
31	532 18 76-90	Washer, Spacer	214	532 19 37-82	Bolt/Washer Asm. 5/16-18
32	532 15 35-32	Pulley, Mandrel	304	<b>532 41 05-20</b>	Shield Side LH
33	532 40 02-34	Nut, Toplock	305	<b>532 41 05-21</b>	Shield Side RH
36	532 13 14-94	Pulley, Idler, Flat	--	532 19 25-58	Brake Assembly (Includes Stand, Arm and Guard Components)
37	532 19 31-98	Pulley Idler Flat	--	532 19 28-70	Mandrel Assembly (Includes Housing, Shaft and Shaft Hardware Only - Pulley Not Included)
40	873 68 06-00	Nut, Crownlock 3/8-16 unc	--	532 19 36-46	Replacement Mower, Complete
45	532 12 47-88	Retainer			
46	532 13 77-29	Screw 1/4-20 x 5/8			
55	532 13 38-40	Idler Arm Assembly			
56	532 16 57-23	Spacer, Retainer			
67	532 10 69-32	Knob			
68	532 19 32-14	V-Belt			
72	532 19 32-16	Spring Brake Return			
89	819 13 13-11	Washer 13/32 x 13/16 x 11 Ga.			
107	532 13 35-02	Spacer Retainer			
108	532 13 35-03	Stiffener, Idler Arm			

**NOTE:** All component dimensions given in U.S. inches  
1 inch = 25.4 mm

# REPAIR PARTS

TRACTOR-MODEL NUMBER PF135B97 (96011025701), PRODUCT NO. 960 11 02-57  
DECALS

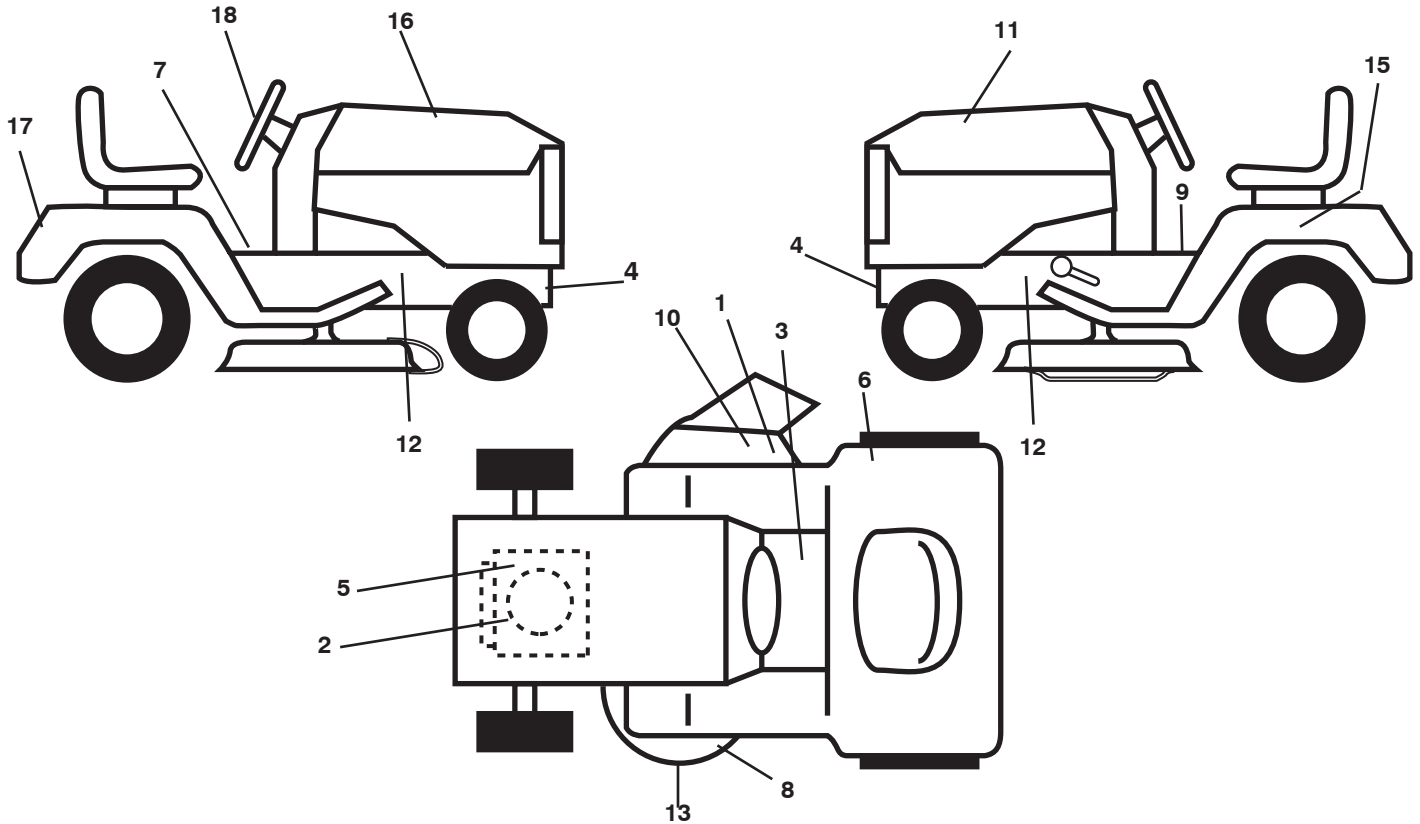

KEY NO.	PART NO.	DESCRIPTION	KEY NO.	PART NO.	DESCRIPTION
1	532 19 63-57	Decal, Deflect Wrn. Cutfinger Sym.	12	532 19 68-42	Decal, Chassis
2	532 40 88-15	Decal, Engine HP	13	532 13 49-99	Decal, Enviro
3	532 15 97-37	Decal, Brake/Clutch	15	532 14 50-05	Decal, Caution, Battery
4	532 15 97-36	Decal, Hot Muffler	16	532 41 00-98	Decal, Hood RH
5	532 19 68-41	Decal, Warning Engine Sym.	17	532 40 29-11	Decal, Fender
6	532 18 04-32	Decal, DB/CE	18	532 40 29-13	Decal, Wheel Steering
7	532 40 03-89	Decal, Read Owner's Manual	--	532 16 25-98	Decal, Drawbar
8	532 19 43-02	Decal, V-Belt Sch.	--	532 13 83-11	Decal, Handle Lft Height Adj.
9	532 14 08-37	Decal, Parking Brake	--	532 18 10-90	Pad, Footrest RH
10	532 18 21-66	Decal, Cutfinger	--	532 18 10-91	Pad, Footrest LH
11	532 41 00-99	Decal, Hood LH	--	<b>532 41 69-22</b>	Manual, Parts
			--	532 41 01-14	Manual, Operator's, Euro

## WHEELS & TIRES

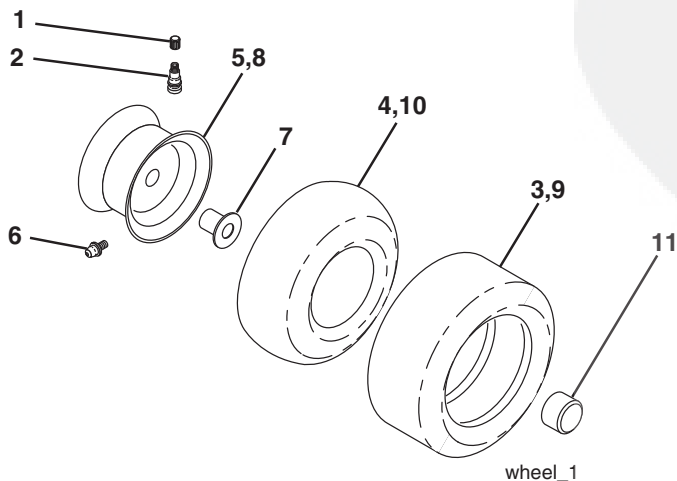

KEY NO.	PART NO.	DESCRIPTION
1	532 05 91-92	Cap, Tire Valve
2	532 06 51-39	Stem, Valve
3	532 12 41-57	Tire, Front
4	532 05 99-04	Tube, Front (Service Item Only)
5	532 13 83-36	Rim Assembly, 6" Front
6	532 12 49-57	Fitting, Grease (Front Wheel Only)
7	532 12 49-59	Bearing, Flange (Front Wheel Only)
8	532 13 83-37	Rim Assembly, 8" Rear
9	532 12 39-69	Tire, Rear
10	532 12 49-26	Tube, Rear (Service Item Only)
11	532 17 50-39	Cap, Hub Axle
--	532 14 43-34	Sealant, Tire (10 oz. Tube)

**NOTE:** All component dimensions given in U.S. inches  
1 inch = 25.4 mm

---

# SERVICE NOTES

---

