

**REPAIR PARTS MANUAL**  
**MODEL NO. BM155B107HK (96011024301)**  
**Lawn Tractor**

---

***BESTGREEN***

# HOW TO USE THIS MANUAL

This manual is designed to provide the customer with a means to identify the parts on his/her tractor when ordering repair parts. The illustrations may or may not represent the actual assemblies; therefore, it is not recommended to use this manual as a guide to assemble or disassemble the tractor. Some hardware and parts are drawn larger in order to more readily identify them.

Each tractor has its own model number.

The model number for your tractor can be found on the fender under the seat.

When ordering parts, always give the following information:

- Product - "Lawn Tractor"
- Model Number - BM155B107HK (96011024301)
- Part Number
- Part Description

## TABLE OF CONTENTS

<b>SCHEMATIC .....</b>	<b>3</b>
<b>ELECTRICAL.....</b>	<b>4-5</b>
<b>CHASSIS AND ENCLOSURES.....</b>	<b>6-7</b>
<b>DRIVE.....</b>	<b>8-9</b>
<b>STEERING ASSEMBLY.....</b>	<b>10-11</b>
<b>ENGINE.....</b>	<b>12-13</b>
<b>MOWER DECK .....</b>	<b>14-15</b>
<b>MOWER LIFT.....</b>	<b>16-17</b>
<b>SEAT ASSEMBLY .....</b>	<b>18</b>
<b>DECALS.....</b>	<b>19</b>

# TRACTOR-MODEL NO. BM155B107HK(96011024301),PRODUCT NO. 960 11 02-43 SCHEMATIC

SCH03

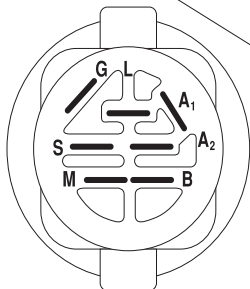
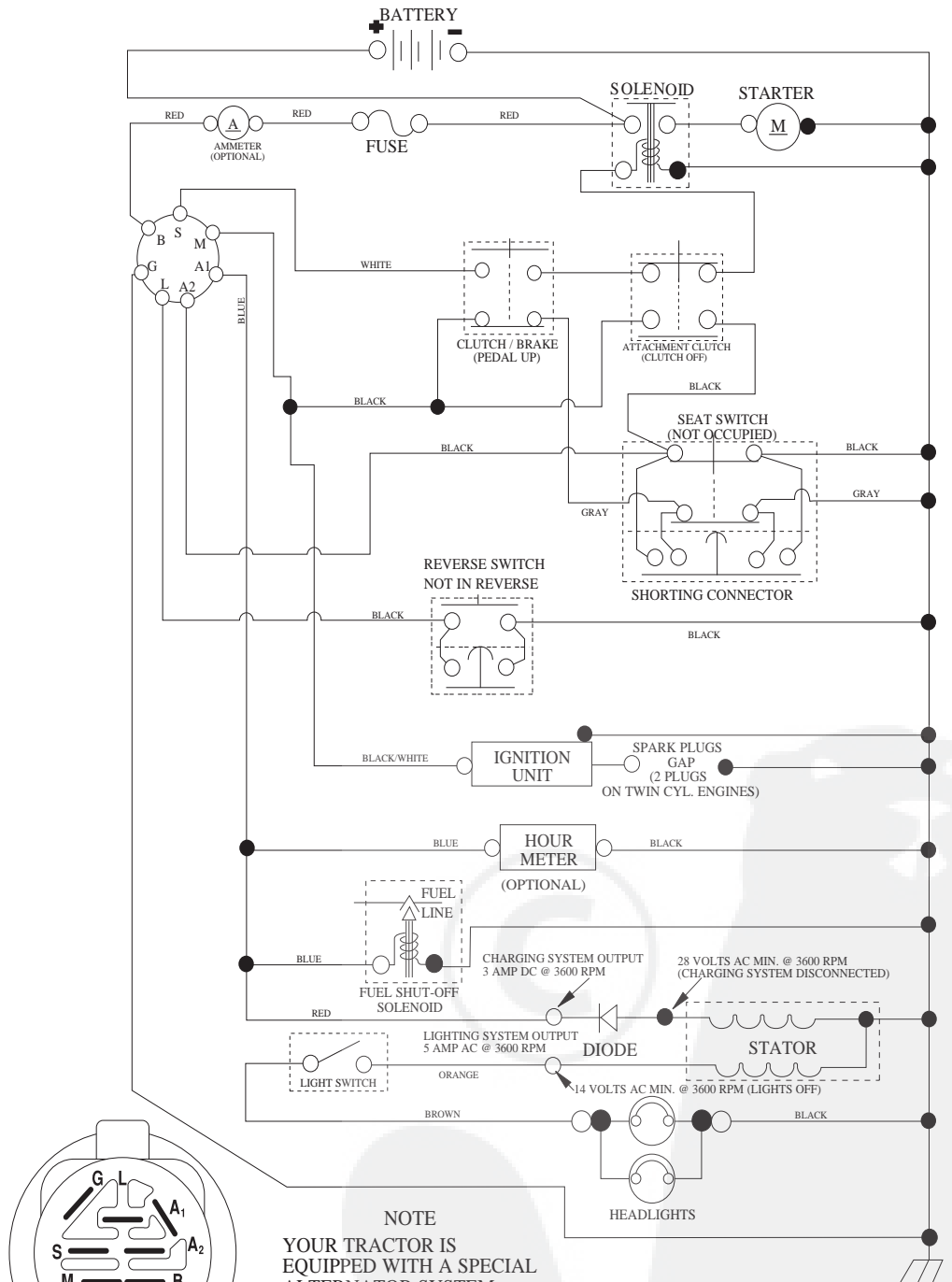

IGNITION SWITCH

POSITION	CIRCUIT	"MAKE"
OFF	M+G+A1	
RUN/OVERRIDE	B+A1	
RUN	B+A1	L+A2
START	B + S + A1	

**NOTE**  
YOUR TRACTOR IS EQUIPPED WITH A SPECIAL ALTERNATOR SYSTEM. THE LIGHTS ARE NOT CONNECTED TO THE BATTERY, BUT HAVE THEIR OWN ELECTRICAL SOURCE. BECAUSE OF THIS, THE BRIGHTNESS OF THE LIGHTS WILL CHANGE WITH ENGINE SPEED. AT IDLE THE LIGHTS WILL DIM. AS THE ENGINE IS SPEEDED UP, THE LIGHTS WILL BECOME THEIR BRIGHTEST.

NON-REMOVABLE CONNECTIONS  
REMOVABLE CONNECTIONS

WIRING INSULATED CLIPS  
NOTE: IF WIRING INSULATED CLIPS WERE REMOVED FOR SERVICING OF UNIT, THEY SHOULD BE RE-INSTALLED TO PROPERLY SECURE YOUR WIRING.

**TRACTOR-MODEL NO. BM155B107HK(96011024301),PRODUCT NO. 960 11 02-43  
ELECTRICAL**

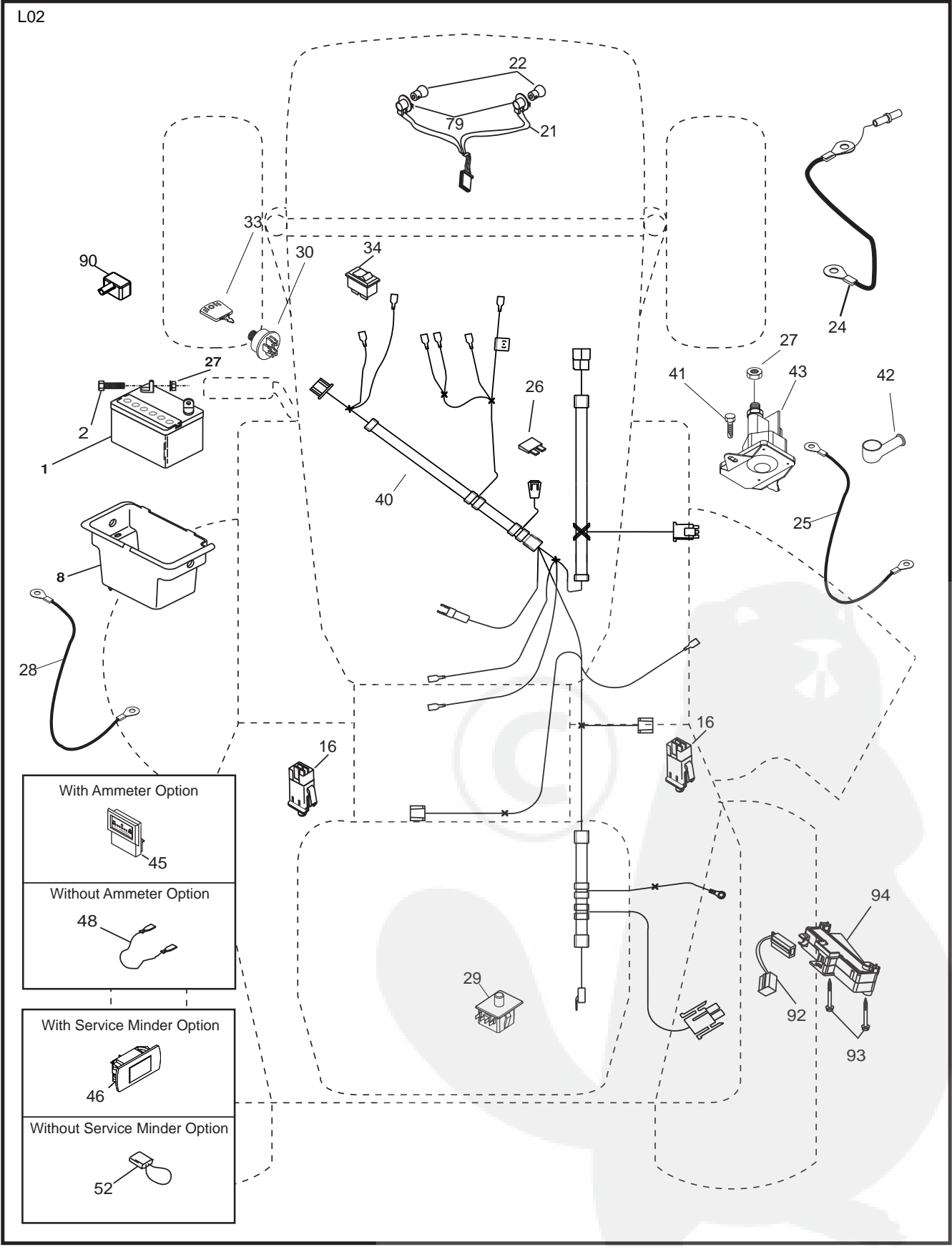

**TRACTOR-MODEL NO. BM155B107HK(96011024301),PRODUCT NO. 960 11 02-43  
ELECTRICAL**

<b>KEY NO.</b>	<b>PART NO.</b>	<b>DESCRIPTION</b>
1	532 16 34-65	Battery
2	874 76 04-12	Bolt Hex Hd 1/4-20 unc x 3/4
8	532 17 66-89	Box Battery
16	532 17 61-38	Switch Interlock
21	532 18 37-59	Harness Asm Light W/4152j
22	532 00 41-52	Bulb Light
24	532 12 47-80	Cable Battery 6 Ga. 11" red
25	532 14 61-47	Cable Battery 6 Ga. 44" red w/16 wire
26	532 17 51-58	Fuse 20 AMP
27	873 51 04-00	Nut Keps Hex 1/4-20 unc
28	532 12 47-73	Cable Ground 6 Ga. 12" black
29	532 19 27-49	Switch Seat
30	532 19 33-50	Switch Ign
33	<b>532 41 19-35</b>	Key/Chain
34	532 11 07-12	Switch Light/Reset B/B/Red
40	532 19 74-28	Harness Ign.
41	871 11 04-08	Bolt Blk Fin Hex 1/4 - 20 x 1/2
42	532 13 15-63	Cover Terminal Red
43	532 19 25-07	Solenoid
48	532 14 08-44	Adapter Ammeter
52	532 14 19-40	Protection Wire Loop
79	<b>532 17 52-42</b>	Socket Asm Bulb Twistock
90	532 18 04-49	Cover Terminal Battery
92	532 19 66-15	Harness Pigtail Console
93	532 19 25-40	Screw Plastite 10-14 x 2.0
94	532 19 18-34	Module Reverse

**NOTE:** All component dimensions given in U.S. inches.  
1 inch = 25.4 mm.



**TRACTOR-MODEL NO. BM155B107HK(96011024301),PRODUCT NO. 960 11 02-43  
CHASSIS AND ENCLOSURES**

<b>KEY NO.</b>	<b>PART NO.</b>	<b>DESCRIPTION</b>
1	532 17 46-20	Chassis Weldment
2	532 17 65-54	Drawbar
5	532 15 52-72	Bumper Hood/Dash
6	532 18 44-19	Saddle
8	532 15 51-38	Clip Retainer
9	532 19 46-88	Dash P/L
10	872 14 06-08	Bolt Carriage 3/8-16 x 1
11	532 17 49-96	Panel Dash LH
13	532 18 69-52	Panel Dash RH
15	<b>874 18 05-12</b>	Screw 5/16-18 x 3/4
16	<b>873 51 05-00</b>	Nut Keps 5/16-18
17	532 19 24-37	Hood
18	532 18 49-21	Bumper Hood
24	874 78 06-16	Bolt 3/8-16 x 1 Gr. 5
25	819 13 13-12	Washer 13/32 x 13/16 x 12 Ga.
26	873 80 06-00	Nut Lock Hex W/Ins 3/8-16 unc
28	532 18 38-26	Grill/Lens Asm. (Includes key #'s 29 and 212)
29	532 18 98-37	Lens Grille
30	532 40 30-26	Fender
31	532 13 66-19	Bracket Support Fender
33	532 18 64-57	Footrest LH
34	532 18 64-58	Footrest RH
35	872 11 06-06	Bolt 3/8-16 x 3/4
37	817 49 05-08	Screw Thdrol 6/16-18 x 1/2 TYT
38	532 17 57-10	Bracket, Asm. Pivot
39	532 40 78-07	Bracket Pivot
145	<b>532 40 91-67</b>	Rod Pivot Chassis/Hood
205	817 49 06-08	Screw Thdrol 3/8-16 x 1/2
206	532 17 01-65	Bolt Shoulder 5/16-18
208	817 67 06-08	Screw Thdrol 3/8-16 x 1/2
209	817 00 06-12	Screw Hexwsh Thdr 3/8-16 x 3/4 Bl.
212	532 18 38-23	Insert Lens Reflective
278	532 19 16-11	Screw 10 x 3/4 Single Lead-Hex
--	532 00 54-79	Plug Button

**NOTE:** All component dimensions given in U.S. inches  
1 inch = 25.4 mm





**TRACTOR-MODEL NO. BM155B107HK(96011024301),PRODUCT NO. 960 11 02-43  
DRIVE**

KEY NO.	PART NO.	DESCRIPTION	KEY NO.	PART NO.	DESCRIPTION
1	-----	Transaxle Hydro Gear 314-0510 (Order parts from transaxle manufacturer)	71	532 16 91-83	Strap Torque LH Hydro
8	532 19 27-06	Rod Shift Fender STLT	73	532 16 91-82	Strap Torque RH Hydro
10	876 02 04-16	Pin Cotter 1/8 x 1 CAD	74	532 13 70-57	Spacer, Axle
14	810 04 04-00	Washer Lock Hvy Helical 1/4	75	532 12 17-49	Washer 25/32 x 1-1/4 x 16 Ga.
15	874 49 05-44	Bolt Hex Flg Hd 5/16-18 x Gr. 5	76	812 00 00-01	E-Ring
16	873 80 05-00	Nut Lock Hex W/Ins. 5/16-18 unc P	77	532 12 35-83	Key, Square
19	873 80 06-00	Nut Lock Hex W/Wsh 3/8-16 unc	78	532 12 17-48	Washer 25/32 x 1-5/8 x 16 Ga.
21	532 10 69-33	Knob	81	532 16 55-96	Shaft Asm. Cross Hydro
22	532 16 94-98	Rod, Brake Hydro	82	532 16 57-11	Spring Torsion T/A
24	873 35 06-00	Nut	83	819 17 12-16	Washer 17/32 x 3/4 x 16 Ga.
25	532 10 68-88	Spring, Brake Rod	84	532 16 95-94	Link Transaxle
26	819 13 13-16	Washer	89	532 19 49-72	Console, Shift
27	876 02 04-12	Pin Cotter 1/8 x 3/4 CAD.	95	532 17 02-01	Control Asm Bypass Hydro
28	532 17 57-65	Rod, Parking Brake	96	532 12 47-88	Retainer Spring 1" Zinc/Cad
29	532 07 16-73	Cap, Parking Brake	112	819 09 12-10	Washer 9/32 x 3/4 x 10 Ga.
30	532 16 95-92	Bracket, Transaxle	116	872 14 06-08	Bolt Rdhd 3/8-16 x 1
32	874 76 05-12	Bolt Hex Hd 5/16-18 unc x 3/4	120	873 90 06-00	Nut Lock Flg 3/8-16
34	532 17 55-78	Shaft, Foot Pedal, Nibbed	150	532 17 54-56	Spacer Retainer
35	532 12 01-83	Bearing, Nylon	151	819 13 32-10	Washer 13/32 x 2 x 10 Ga.
36	819 21 16-16	Washer	156	532 16 60-02	Washer Srrtd 5/16 ID x 1.0 x .125 Tk
37	532 12 49-63	Pin, Roll	158	532 16 55-89	Bracket Shift Mount
38	532 17 91-14	Pulley, Composite, Flat	159	532 18 39-00	Hub Shift
39	872 11 06-22	Bolt Rdhd 3/8-16 unc x 2-3/4 Gr. 5	161	872 14 04-06	Bolt Rdhd Sqnk 1/4-20 x 3/4 Gr. 5
41	532 17 55-56	Keeper, Belt Idler	162	873 68 04-00	Nut Crownlock 1/4-20 unc
47	532 12 77-83	Pulley, Idler, V-Groove	163	874 78 04-16	Bolt Hex Fin 1/4-20 unc x 1 Gr. 5
48	532 15 44-07	Bellcrank Clutch Grnd Drv Stl	165	532 16 56-23	Bracket Pivot Lever
49	532 12 32-05	Retainer, Belt	166	817 49 05-10	Screw 5/16-18 x 5/8
50	872 11 06-12	Bolt 3/8-16 x 1-1/2 Gr. 5	168	532 16 54-92	Bolt Shoulder 5/16-18 x .561 TT
51	873 68 06-00	Nut Crownlock 3/8-16	169	532 16 55-81	Plate Fastening
52	873 68 05-00	Nut Crownlock 5/16-18	197	532 16 96-13	Nyliner Snap-In 5/8" ID
53	532 19 96-52	Link, Clutch	199	532 16 96-12	Bolt Shoulder 5/16-18 unc
55	532 10 57-09	Spring, Return, Clutch	200	872 14 05-08	Bolt Rdhd Sqnk 5/16-18 unc x 1
56	817 06 06-20	Screw 3/8-16 x 1	202	872 11 06-14	Bolt Carr 3/8-16 x 1-3/4 Gr. 5
57	532 14 02-94	V-Belt, Ground Drive	207	532 16 98-45	Washer Nyl
59	532 16 96-91	Keeper, Center Span	212	532 14 52-12	Nut Hex Flange Lock
61	817 12 06-14	Screw 3/8-16 x 3/4	263	817 00 06-12	Screw 3/8-16 x 3/4
62	532 12 48-72	Cover, Pedal	268	532 18 24-02	Guard Muffler
63	532 18 02-19	Pulley, Eng	275	819 13 16-14	Washer 13/32 x 1 x 14 Ga.
64	532 17 39-37	Bolt Hex 7/16-20 x 4 Ga. 5			
65	810 04 07-00	Washer			
66	532 15 47-78	Keeper Belt Engine			
69	532 14 24-32	Screw Hex Wsh Hi-Lo 1/4 x 1/2 unc			
70	532 18 02-18	Guide Belt Mower Drive RH			

**NOTE:** All component dimensions given in U.S. inches.  
1 inch = 25.4 mm.

TRACTOR-MODEL NO. BM155B107HK(96011024301),PRODUCT NO. 960 11 02-43  
STEERING ASSEMBLY

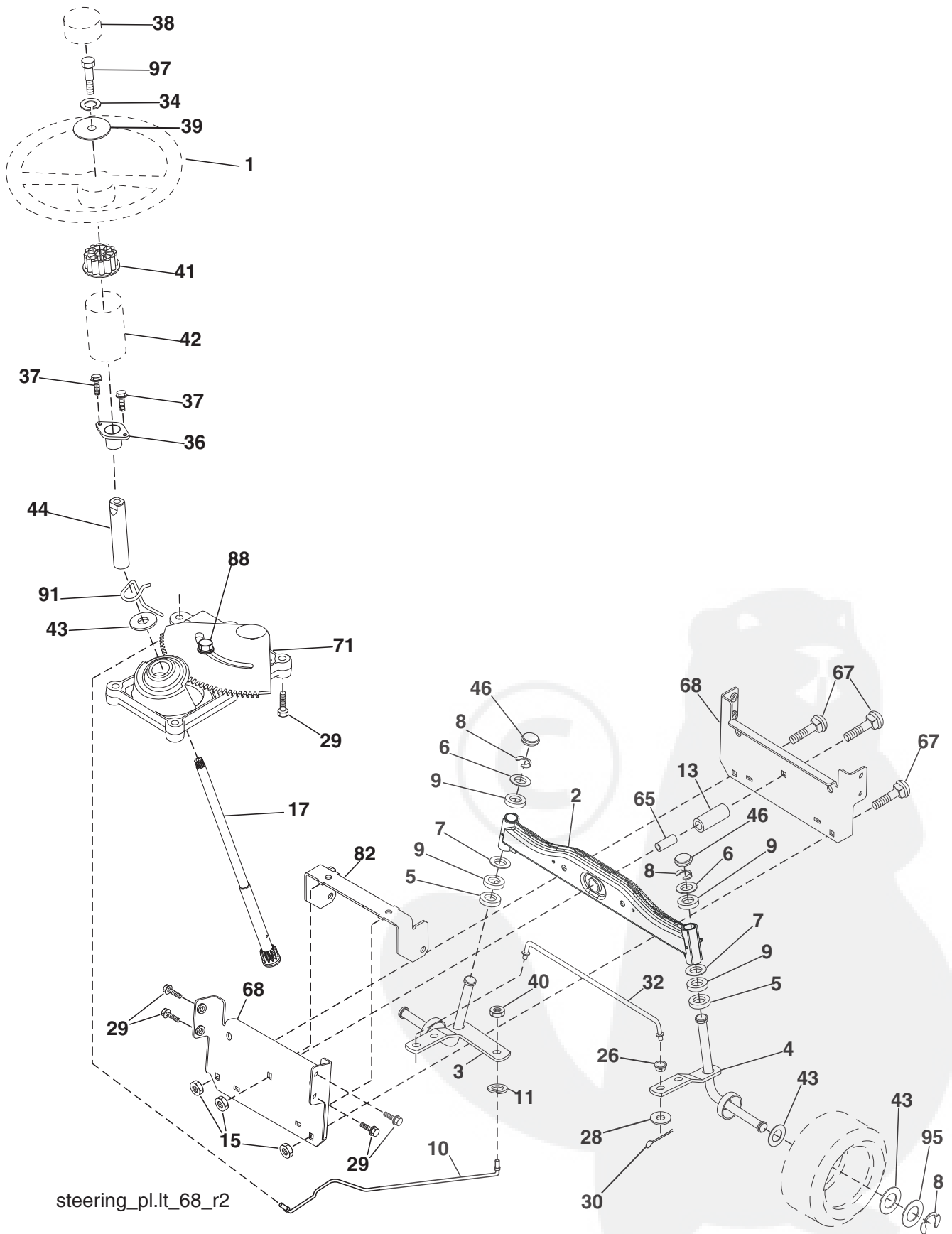

steering\_pl.lt\_68\_r2

**TRACTOR-MODEL NO. BM155B107HK(96011024301),PRODUCT NO. 960 11 02-43  
STEERING ASSEMBLY**

<b>KEY NO.</b>	<b>PART NO.</b>	<b>DESCRIPTION</b>
1	532 19 45-95	Wheel Steering
2	532 19 56-73	Axle Asm
3	532 16 98-40	Spindle Asm LH
4	532 16 98-39	Spindle Asm RH
5	532 12 49-31	Bearing Race Thrust Harden
6	532 12 17-48	Washer 25/32 x 1-5/8 x 16 Ga.
7	819 27 20-16	Washer 27/32 x 1-1/4 x 16 Ga.
8	812 00 00-29	Ring Klip #t5304-75
9	532 12 49-37	Bearing Col Strg Blk
10	532 17 51-21	Link Drag
11	810 04 06-00	Washer Lock Hvy Hlcl Spr 3/8
13	532 13 65-18	Bearing Axle STLT/GT
15	532 14 52-12	Nut Hexflange Lock
17	532 19 07-53	Shaft Strg
26	532 12 68-47	Bushing
28	819 13 14-16	Washer 13/32 x 7/8 x 16 Ga.
29	817 00 06-12	Screw 3/8-16 x 3/4 SMGML
30	876 02 04-12	Pin Cotter 1/8 x 3/4
32	532 19 27-57	Rod Tie
34	810 04 05-00	Washer Lock 5/16
36	532 15 50-99	Bushing Strg
37	532 15 29-27	Screw
38	532 19 46-03	Insert Cap Strg Wh
39	819 11 38-12	Washer 11/32 ID x 2-3/8 OD x 12 Ga.
40	873 54 06-00	Lock nut
41	532 18 67-37	Adaptor Wheel Strg
42	532 16 96-33	Boot Steering Shaft
43	532 12 17-49	Washer 25/32 x 1 1/4 x 16 Ga.
44	532 19 07-52	Extension Steering Shaft Spline
46	532 12 12-32	Cap Spindle Fr Top Blk
65	532 16 03-67	Spacer Axle
67	872 11 06-18	Bolt RDHD SqNK 3/8-16 x 2-1/4
68	532 16 98-27	Axle, Brace
71	532 17 51-46	Steering Asm.
82	532 19 99-78	Bracket Susp Chassis Front
88	532 17 51-18	Bolt Shoulder 7/16-20 unc
91	532 17 55-53	Clip Steering
95	532 18 89-67	Washer Hardened
97	874 78 05-64	Bolt 5/16-18 unc x 4" L Gr. 5

**NOTE:** All component dimensions given in U.S. inches.  
1 inch = 25.4 mm.

**TRACTOR-MODEL NO. BM155B107HK(96011024301),PRODUCT NO. 960 11 02-43  
ENGINE**

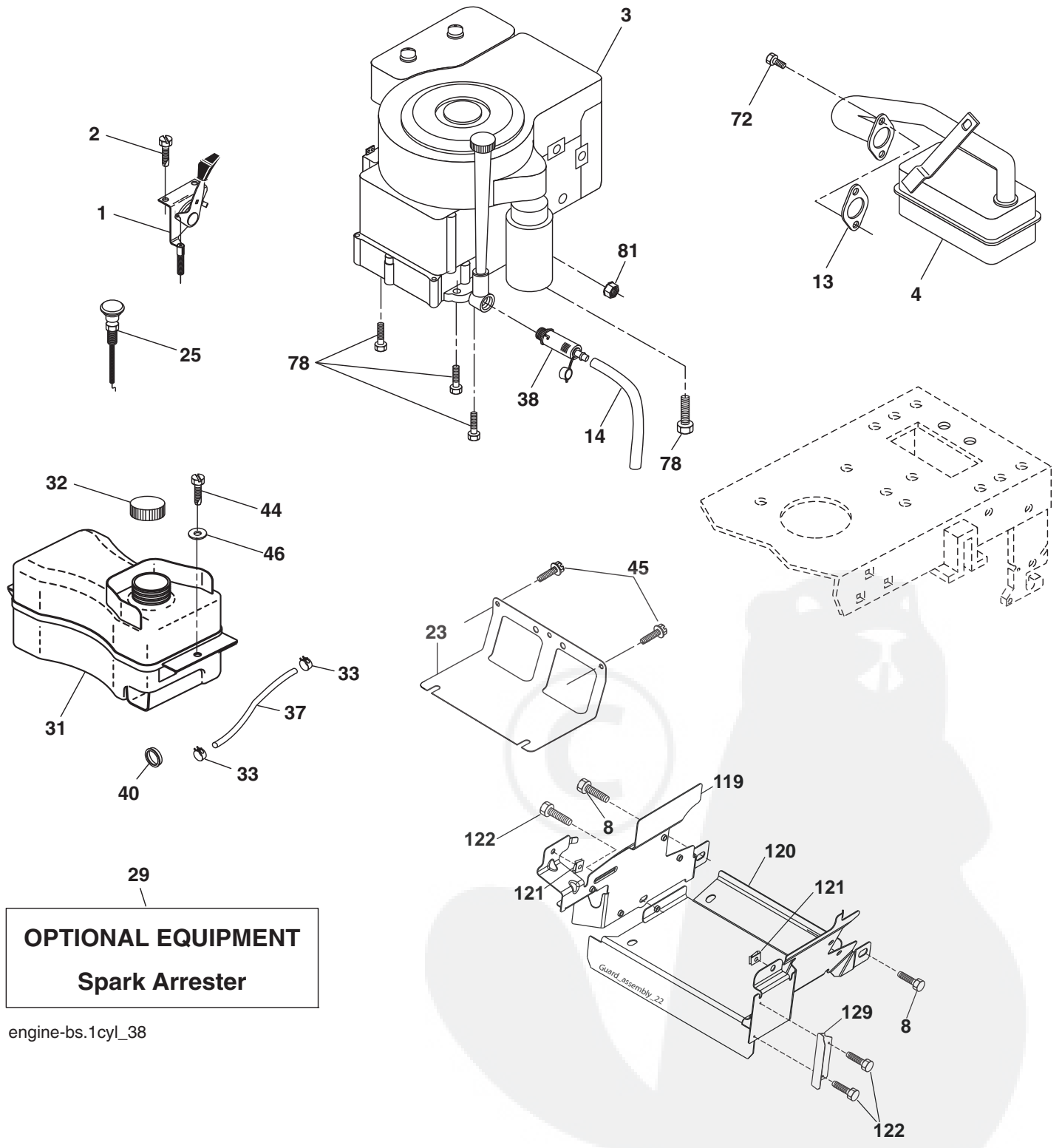

**OPTIONAL EQUIPMENT**  
**Spark Arrester**

engine-bs.1cyl\_38

**TRACTOR-MODEL NO. BM155B107HK(96011024301),PRODUCT NO. 960 11 02-43  
ENGINE**

<b>KEY NO.</b>	<b>PART NO.</b>	<b>DESCRIPTION</b>
1	532 17 05-51	Control, Throttle/Choke
2	817 72 04-08	Screw, Hex Thd Cut 1/4-20 x 1/2
3	-----	Engine, B & S Model No. 31A607 (Order parts from engine manufacturer)
4	532 13 73-52	Muffler Exhaust
8	532 17 18-77	Bolt
13	532 16 52-91	Gasket, Muffler
14	532 14 84-56	Tube Drain Oil Easy
23	532 16 98-37	Shield, Brn/Dbr Guard
25	532 19 06-95	Control Choke
29	532 13 71-80	Arrestor, Spark
31	532 40 75-16	Tank, Fuel
32	532 19 77-25	Cap Fuel
33	532 12 34-87	Clamp, Hose
37	532 13 70-40	Line, Fuel
38	532 18 16-54	Plug, Oil Drain Easy
40	532 12 40-28	Bushing Snap
44	817 67 04-12	Screw 1/4-20 x 3/4
45	817 00 06-12	Screw Hex Wsh 3/8-16 x 3/4
46	819 09 14-16	Washer 9/32 x 7/8 x 16 Ga.
72	532 19 23-34	Screw Socket Head 5/16-18 x .75
78	817 06 06-20	Screw 3/8-16 x 1-1/4
81	873 51 04-00	Nut Keps Hex 1/4-20 Starter Nut
119	532 19 79-49	Guard Asm Engine LH CRD
120	532 19 79-48	Guard Asm Engine RH CRD
121	532 19 66-88	Clips Threaded
122	532 13 77-29	Screw THDROL 1/4 - 20 X 5/8
129	532 40 03-28	Guard Pulley Eng Adapter

**NOTE:** All component dimensions given in U. S.  
inches 1 inch = 25.4 mm

**Engine Power Rating Information**

The gross power rating for individual gas engine models is labeled in accordance with SAE (Society of Automotive Engineers) code J11940 (Small Engine Power & Torque Rating Procedure), and rating performance has been obtained and corrected in accordance with SAE J1995 (Revision 2002-5). Actual gross engine power will be lower and is affected by, among other things, ambient operating conditions and engine-to-engine variability. Given both the wide array of products on which engines are placed and the variety of environmental issues applicable to operating the equipment, the gas engine will not develop the rated gross power when used in a given piece of power equipment (actual "on-site" or net horsepower). This difference is due to a variety of factors including, but not limited to, accessories (air cleaner, exhaust, charging, cooling, carburetor, fuel pump, etc.), application limitations, ambient operating conditions (temperature, humidity, altitude), and engine-to-engine variability. Due to manufacturing and capacity limitations, Briggs & Stratton may substitute an engine of higher rated power for this Series engine.

TRACTOR-MODEL NO. BM155B107HK(96011024301),PRODUCT NO. 960 11 02-43  
MOWER DECK

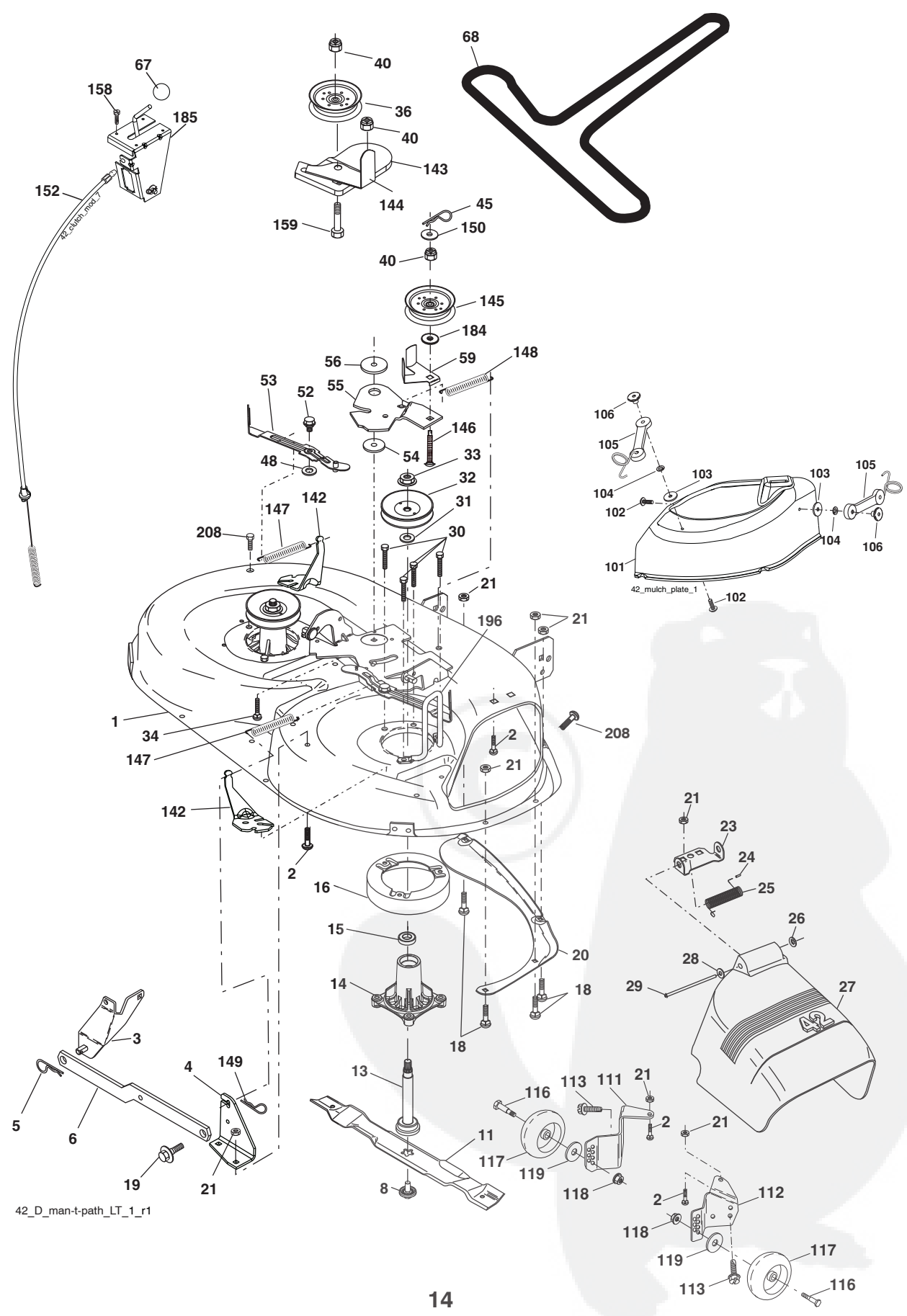

42\_D\_man-t-path\_LT\_1\_r1

**TRACTOR-MODEL NO. BM155B107HK(96011024301),PRODUCT NO. 960 11 02-43  
MOWER DECK**

KEY NO.	PART NO.	DESCRIPTION	KEY NO.	PART NO.	DESCRIPTION
1	532 16 58-92	Deck Asm MWR 42"weldment	101	532 19 31-07	Cover Mulching
2	872 14 05-06	Bolt Rdhd Sqnk 5/16-18 unc x 3/4	102	871 08 10-10	Screw 10-24 x 5/8
3	532 13 80-17	Bracket Asm Fr Sway Bar 38/42	103	819 06 12-16	Washer
4	532 16 54-60	Bracket Asm Deck 42"sway Bar	104	810 07 10-00	Washer Lock
5	532 12 46-70	Retainer Spring	105	532 16 07-93	Latch Asm
6	532 17 80-24	Bar Sway Deck	106	532 12 50-04	Nut Weld
8	532 19 30-03	Bolt/Washer Asm 7/16-20 unf	111	532 40 47-84	Bracket Wheel Gauge LH 42" Deck
11	532 13 41-49	Blade Mulching	112	532 40 47-85	Bracket Gauge Wheel RH 42" Deck
13	532 19 28-72	Shaft Asm Mandrel	113	817 00 05-10	Screw 5/16-18
14	532 18 72-81	Housing Mandrel	116	532 12 48-42	Bolt Shoulder
15	532 11 04-85	Bearing Ball Mandrel	117	532 18 86-06	Wheel Gauge
16	532 17 44-93	Stripper Mower Vented	118	873 93 06-00	Nut Centerlock 3/8-16 unc
18	872 14 05-05	Bolt Rdhd Sqnk 5/16-18 x 5/8	119	819 12 14-14	Washer 3/8 x 7/8 x 14 Ga.
19	532 13 28-27	Bolt Shoulder	142	532 19 57-84	Arm Spring Brake Mower
20	532 15 97-70	Baffle Vortex 42	143	532 15 71-09	Bracket Arm Idler 42"
21	873 68 05-00	Nut Crownlock 5/16-18 unc	144	532 15 86-34	Keeper Belt 42" Clutch Idler
23	532 17 75-63	Bracket Deflector Mower 42"	145	532 16 58-88	Pulley Idler Flat
24	532 10 53-04	Cap Sleeve 80x 112 Blk Mower	146	532 17 19-77	Bolt Carriage Idler
25	532 12 37-13	Spring Torsion Deflector 2 52	147	532 17 97-48	Spring Extension
26	532 11 04-52	Nut Push Phos & Oil	148	532 16 90-22	Spring Return Idler
27	532 40 14-31	Shield Deflector Mower	149	532 16 58-98	Retainer Spring Yellow
28	819 11 10-16	Washer 11/32 x 5/8 x 16 Ga.	150	819 09 12-10	Washer 9/32 x 3/4 x 10 Ga.
29	532 13 14-91	Rod Hinge 42"6 75 Wlg	152	532 18 15-55	Clutch Cable 42"
30	532 17 39-84	Screw Thd Rolling Washer Head	158	817 72 04-08	Screw Hex Thd Cut 1/4-20 x 1/2
31	532 18 76-90	Washer Spacer	159	872 14 06-14	Bolt Rdhd Sqn 3/8-16 unc x 1-3/4
32	532 15 35-35	Pulley Mandrel 42"	184	819 13 14-10	Washer 13/32 x 7/8 x 10 Ga.
33	532 40 02-34	Nut Flange Lock Top	185	532 18 82-34	Head Asm. Cable Clutch
34	872 11 06-12	Bolt Rdhd 3/8-16 unc x 1-1/2 Gr. 5	208	817 67 06-08	Screw 3/8-16 x 1/2
36	532 13 14-94	Pulley Idler Flat 3 060	210	<b>532 40 92-59</b>	Mandrel Cover RH
40	873 90 06-00	Nut Lock Flg 3/8-16 unc	211	<b>532 40 92-58</b>	Mandrel Cover LH
45	532 12 47-88	Spring Retainer 1" Zinc/cad	--	532 19 28-70	Mandrel Asm Service (Includes Housing, Shaft and Shaft Hardware Only-Pulley Not Included)
46	532 13 77-29	Screw Hex Thd Cut 1/4-20 x 5/8 T			Replacement Mower, Complete (Std. Deck - Order separately gauge wheel components key nos. 116-119)
48	532 13 39-44	Washer Hardened Smaller			
52	532 13 98-88	Bolt Shoulder 5/16-18 unc Blkz	--	532 40 15-32	
53	532 18 49-07	Arm Asm Pad Brake			
54	532 17 85-15	Washer Hardened			
55	532 15 50-46	Arm Idler 42"mower LT/YT			
56	532 16 57-23	Spacer Retainer Mower			
59	532 14 10-43	Guard TUV Idler			
67	532 10 69-32	Knob Rd 3/8-16 Plstc Thds Blk			
68	532 18 02-15	V-Belt Mower 42"			

**NOTE:** All component dimensions given in U.S. inches  
1 inch = 25.4 mm

TRACTOR-MODEL NO. BM155B107HK(96011024301),PRODUCT NO. 960 11 02-43  
MOWER LIFT

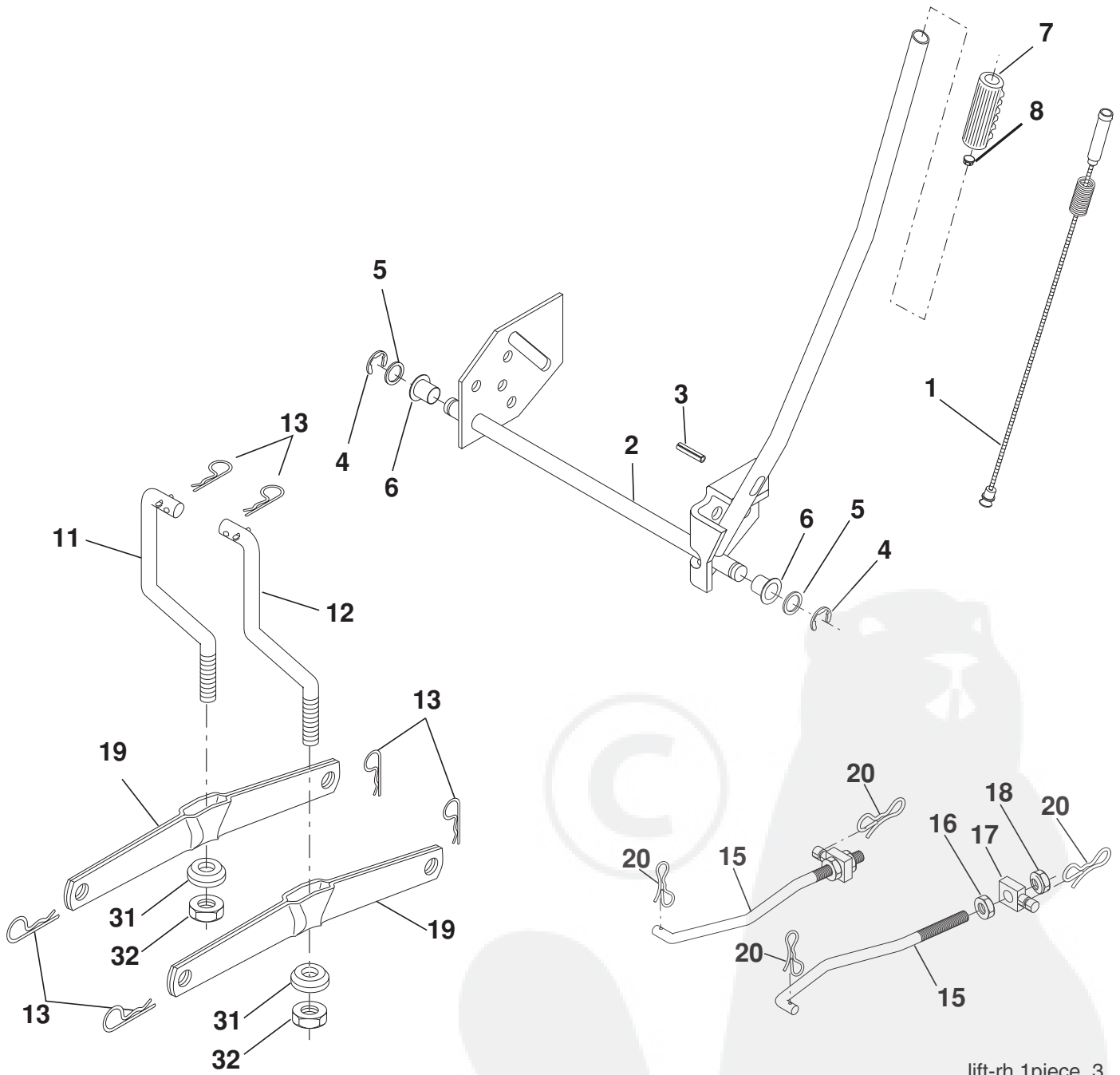

lift-rh.1piece\_3



**TRACTOR-MODEL NO. BM155B107HK(96011024301),PRODUCT NO. 960 11 02-43  
MOWER LIFT**

<b>KEY NO.</b>	<b>PART NO.</b>	<b>DESCRIPTION</b>
1	532 19 84-17	Wire Asm Inner Spring W/Plunger
2	532 19 80-70	Shaft Asm. Lift
3	532 18 88-22	Pin Groove
4	812 00 00-02	E Ring #5133-62
5	819 21 16-21	Washer 21/32 x 1 x 21 Ga.
6	532 12 01-83	Bearing Nylon
7	532 10 94-13	Grip Handle
8	532 12 45-26	Button Plunger
11	532 13 98-65	Link Lift LH
12	532 13 98-66	Link Lift RH
13	532 12 46-70	Retainer Spring
15	532 17 32-88	Link Front
16	873 35 08-00	Nut Jam Hex 1/2-13 unc
17	532 17 56-89	Trunnion
18	873 80 08-00	Nut Lock W/Wsh 1/2-13 unc
19	532 13 98-68	Arm Suspension Mower
20	532 19 42-09	Retainer Spring
31	532 16 98-65	Bearing Pvt. Lift
32	873 54 06-00	Nut Crownlock 3/8-24

**NOTE:** All component dimensions given in U.S. inches  
1 inch = 25.4 mm



**TRACTOR-MODEL NO. BM155B107HK(96011024301),PRODUCT NO. 960 11 02-43  
SEAT ASSEMBLY**

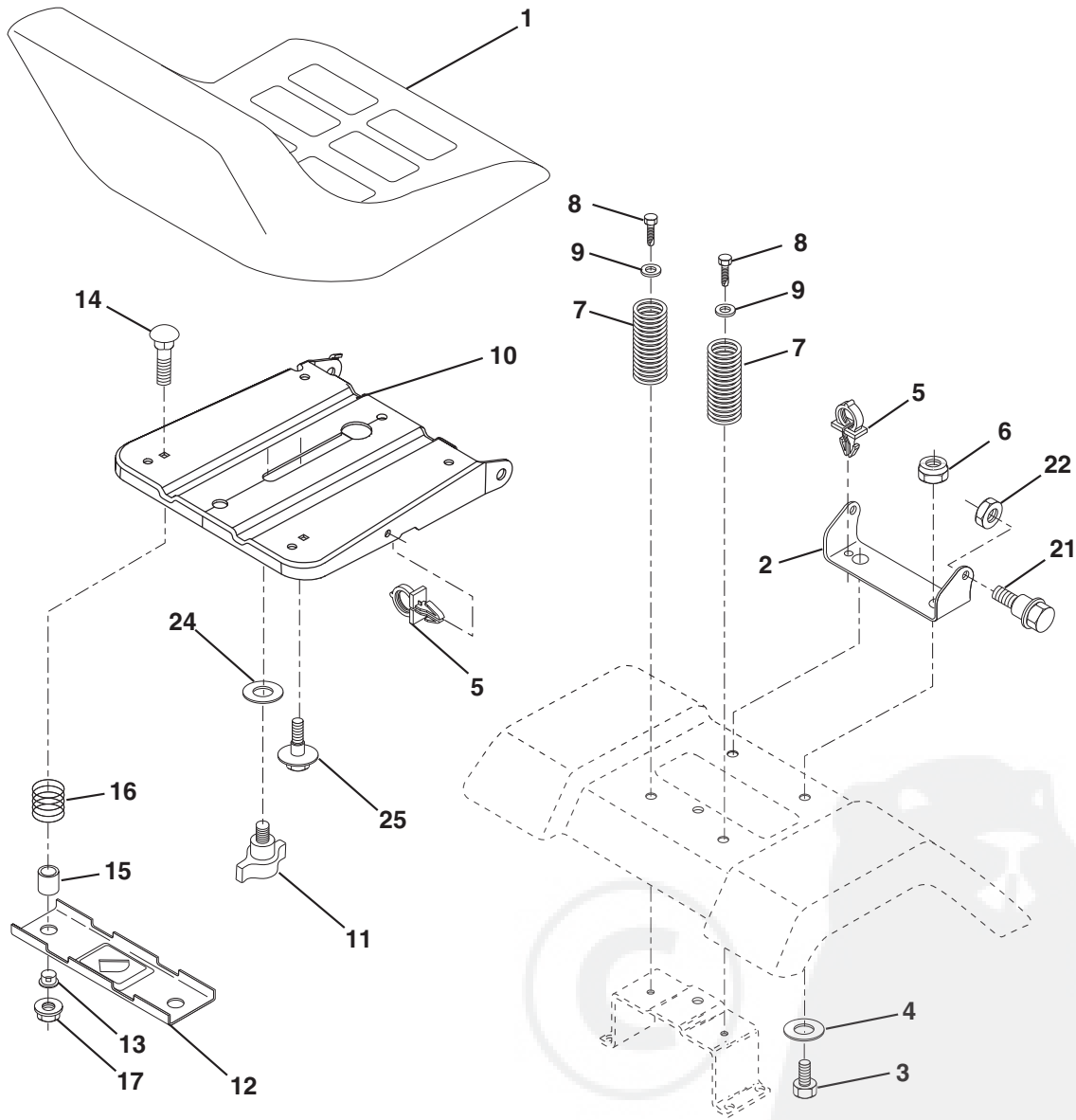

seat\_lt.knob\_13

KEY NO.	PART NO.	DESCRIPTION
1	532 18 87-13	Seat
2	532 14 05-51	Bracket Pivot Seat
3	871 11 06-16	Bolt 3/8-16 x 1
4	819 13 16-10	Washer 13/32 x 1 x 10 Ga.
5	532 14 50-06	Clip Push-In
6	873 80 06-00	Nut Hex w/Ins. 3/8-16 unc
7	532 12 41-81	Spring Seat Cprsn 2 250 Blk Zi
8	817 00 06-16	Screw 3/8-16 x 1.5 SMGML
9	819 13 16-14	Washer 13/32 x 1 x 14 Ga.
10	532 19 55-30	Pan Seat
11	532 16 63-69	Knob Seat
12	532 17 46-48	Bracket Mounting Switch

KEY NO.	PART NO.	DESCRIPTION
13	532 12 12-48	Bushing Snap Blk Nyl 50 Id
14	872 05 04-12	Bolt 1/4-20 x 1-1/2
15	532 13 43-00	Spacer Split 28 x 96 Yel Zinc
16	532 12 12-50	Spring Cprsn 1.27 Blk Pnt
17	532 12 39-76	Nut Lock 1/4 Lge Flg Gr. 5 Zinc
21	532 17 18-52	Bolt SHLD 5/16-18 unc-2A
22	873 80 05-00	Nut Hex Lock W/Ins 5/16-18
24	819 17 19-12	Washer 17/32 x 1-3/16 x 12 Ga.
25	532 12 70-18	Bolt Shoulder 5/16-18 x .62

**NOTE:** All component dimensions given in U.S. inches.  
1 inch = 25.4 mm

**TRACTOR-MODEL NO. BM155B107HK(96011024301),PRODUCT NO. 960 11 02-43  
DECALS**

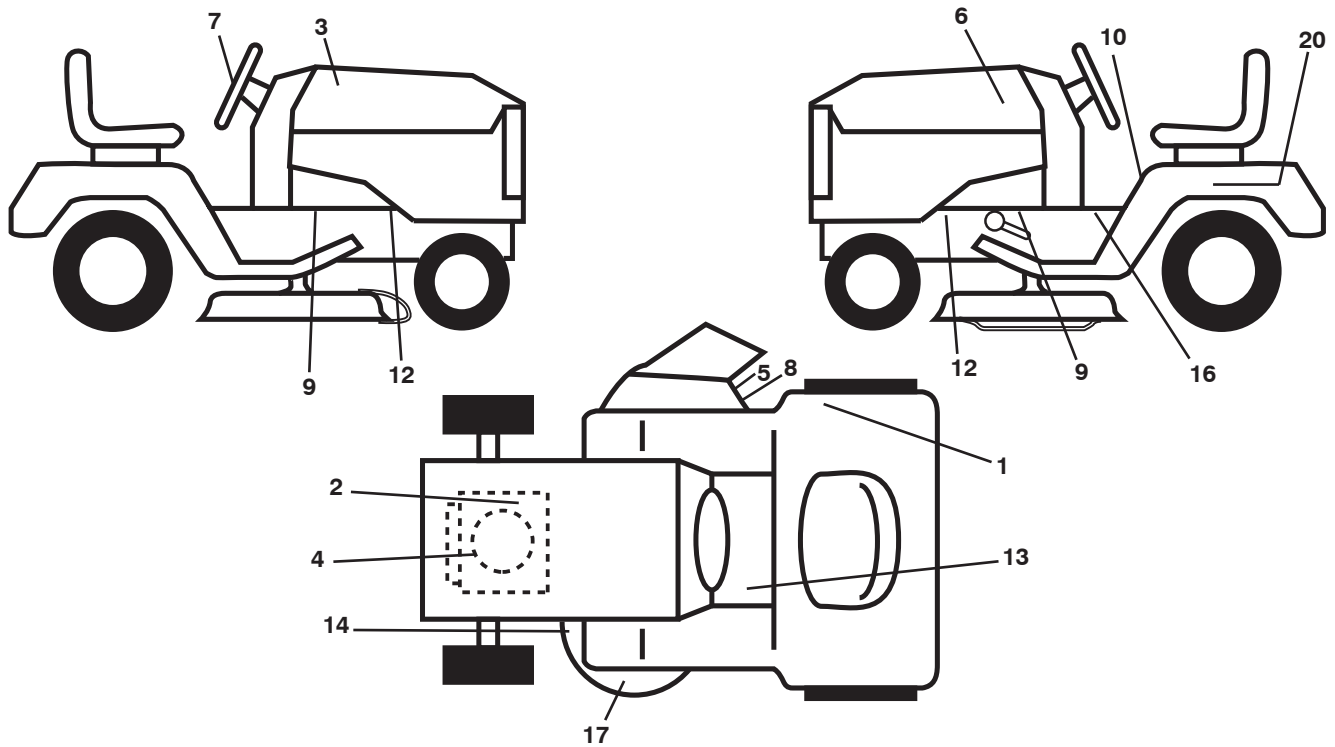

KEY NO.	PART NO.	DESCRIPTION
1	532 18 04-32	Decal, DBA
2	532 19 68-41	Decal, Warning Eng. Sym.
3	532 40 84-83	Decal, Hood RH
4	<b>532 41 67-26</b>	Decal, Eng. HP
5	532 18 21-66	Decal, Mower Cuttinger
6	532 40 84-84	Decal, Hood LH
7	532 19 44-19	Decal, Ins. Strg Whl.
8	532 19 63-57	Decal, Deflect Wrn. Cuttinger Sym
9	<b>532 19 68-42</b>	Decal, SDL/CRD Sym Cuttinger
10	532 40 03-89	Decal, Warning Sym. CE
12	532 15 97-36	Decal, Chassis Hot Muffler

KEY NO.	PART NO.	DESCRIPTION
13	532 15 97-37	Decal, Brake/Clutch Symbol LT
14	532 16 03-96	Decal, V-Belt Schematic
16	532 14 08-37	Decal, Saddle Brake Parking
17	532 13 49-99	Decal, Mower Enviro
20	532 14 50-05	Decal, Bat Dan/Psn
--	532 16 69-60	Decal, Bypass
--	532 16 25-98	Decal, Drawbar Load Limit
--	532 13 83-11	Decal, Handle Lift Height Adjust
--	532 18 10-91	Pad, Footrest LH STLT
--	532 18 10-90	Pad, Footrest RH STLT
--	532 40 82-71	Manual Operator's (Euro.)
--	<b>532 41 65-03</b>	Manual Parts

**WHEELS & TIRES**

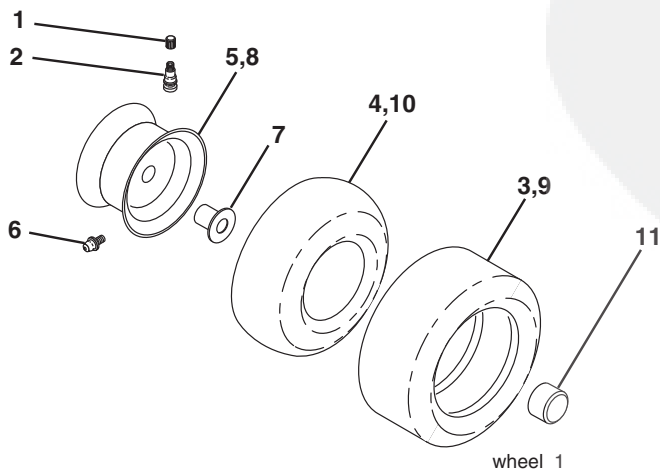

KEY NO.	PART NO.	DESCRIPTION
1	532 05 91-92	Cap Valve Tire
2	532 06 51-39	Stem Valve
3	532 10 62-22	Tire F Ts 15 x 6 0 - 6 Service
4	532 05 99-04	Tube Front (Service Item Only)
5	532 13 83-36	Rim Asm 6" Front Service
6	532 12 49-57	Fitting Grease (Front Wheel Only)
7	532 12 49-59	Bearing Flange (Front Wheel Only)
8	532 13 83-37	Rim Asm 8" Rear Service
9	532 13 84-68	Tire R Ts 20 x 8-8 x 8 5-8 C Service
10	532 12 49-26	Tube Rear (Service Item Only)
11	532 17 50-39	Cap Axle Blk 1 50 x 1 00
--	532 14 43-34	Sealant, Tire ( 10 oz. Tube)

**NOTE:** All component dimensions given in U.S. inches  
1 inch = 25.4 mm

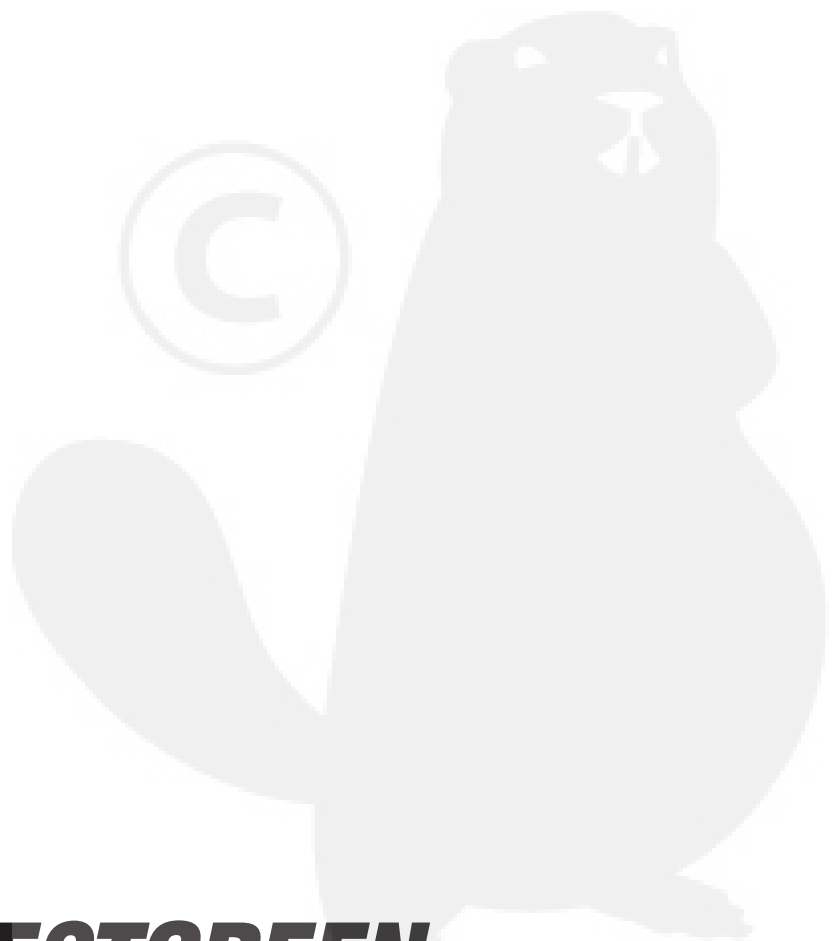

***BESTGREEN***