

REPAIR PARTS MANUAL
MODEL NO. RE20H122 (96011017202)
Lawn Tractor

Rally

HOW TO USE THIS MANUAL

This manual is designed to provide the customer with a means to identify the parts on his/her tractor when ordering repair parts. The illustrations may or may not represent the actual assemblies; therefore, it is not recommended to use this manual as a guide to assemble or disassemble the tractor. Some hardware and parts are drawn larger in order to more readily identify them.

Each tractor has its own model number.

The model number for your tractor can be found on the fender under the seat.

When ordering parts, always give the following information:

- Product - "Tractor"

- Model Number - "RE20H122(96011017202)"
- Part Number
- Part Description

TABLE OF CONTENTS

SCHEMATIC	3
ELECTRICAL.....	4-5
CHASSIS	6-7
DRIVE.....	8-9
STEERING	10-11
SEAT	12
ENGINE.....	13
MOWER DECK	14-15
MOWER LIFT.....	16-17
DECALS.....	18

TRACTOR - MODEL NO. RE20H122 (96011017202), PRODUCT NO. 960 11 01-72 SCHEMATIC

SCH04

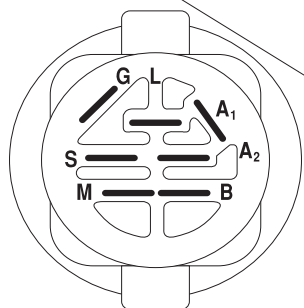
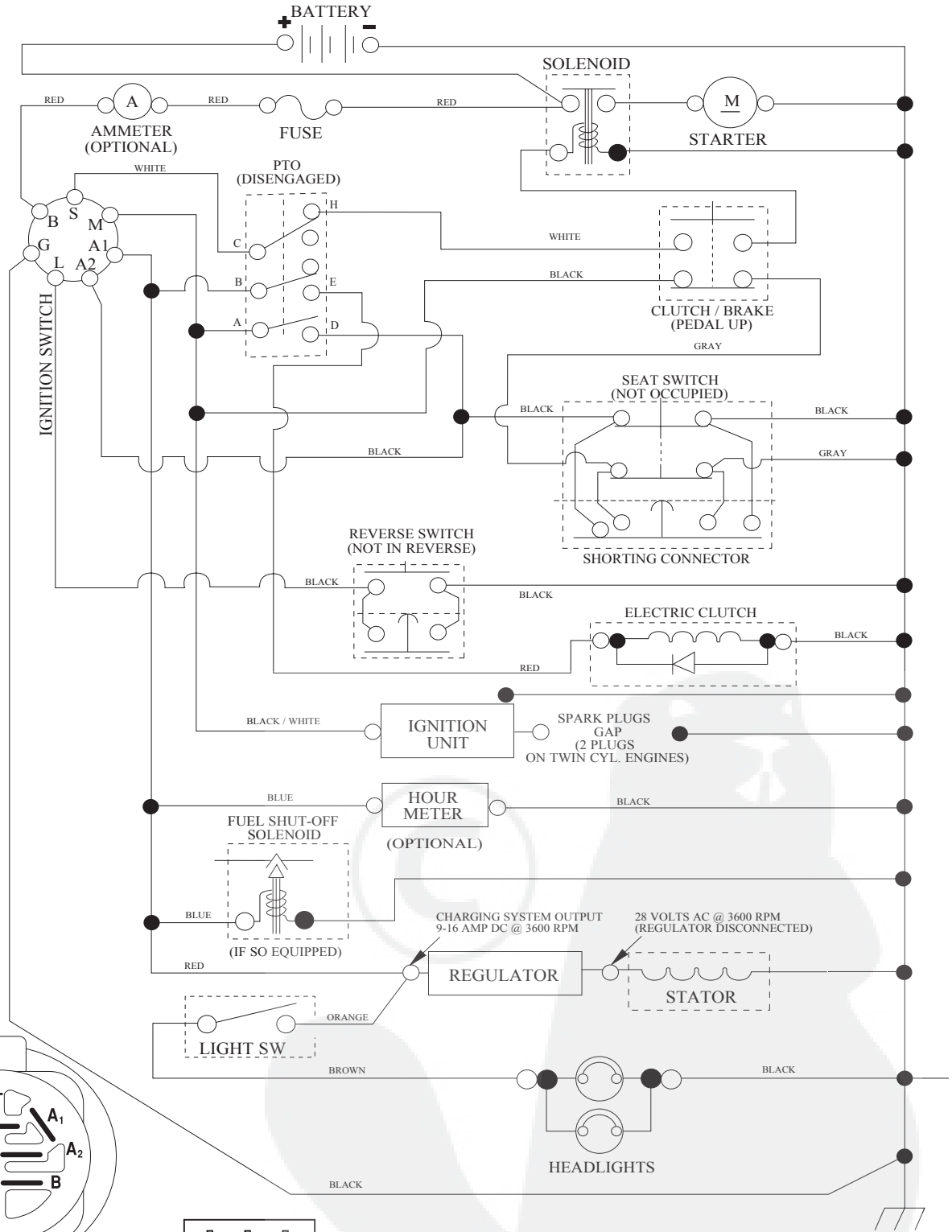

IGNITION SWITCH

POSITION	CIRCUIT	"MAKE"
OFF	M+G+A1	NONE
RUN/OVERRIDE	B+A1	NONE
RUN	B+A1	L+A2
START	B + S + A1	NONE

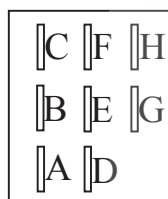

PTO SWITCH
(MATING SIDE)

WIRING INSULATED CLIPS
NOTE: IF WIRING INSULATED CLIPS
WERE REMOVED FOR SERVICING OF
UNIT, THEY SHOULD BE RE-INSTALLED
TO PROPERLY SECURE YOUR WIRING.

○
REMOVABLE
CONNECTIONS

●
NON-REMOVABLE
CONNECTIONS

**TRACTOR - MODEL NO. RE20H122 (96011017202), PRODUCT NO. 960 11 01-72
ELECTRICAL**

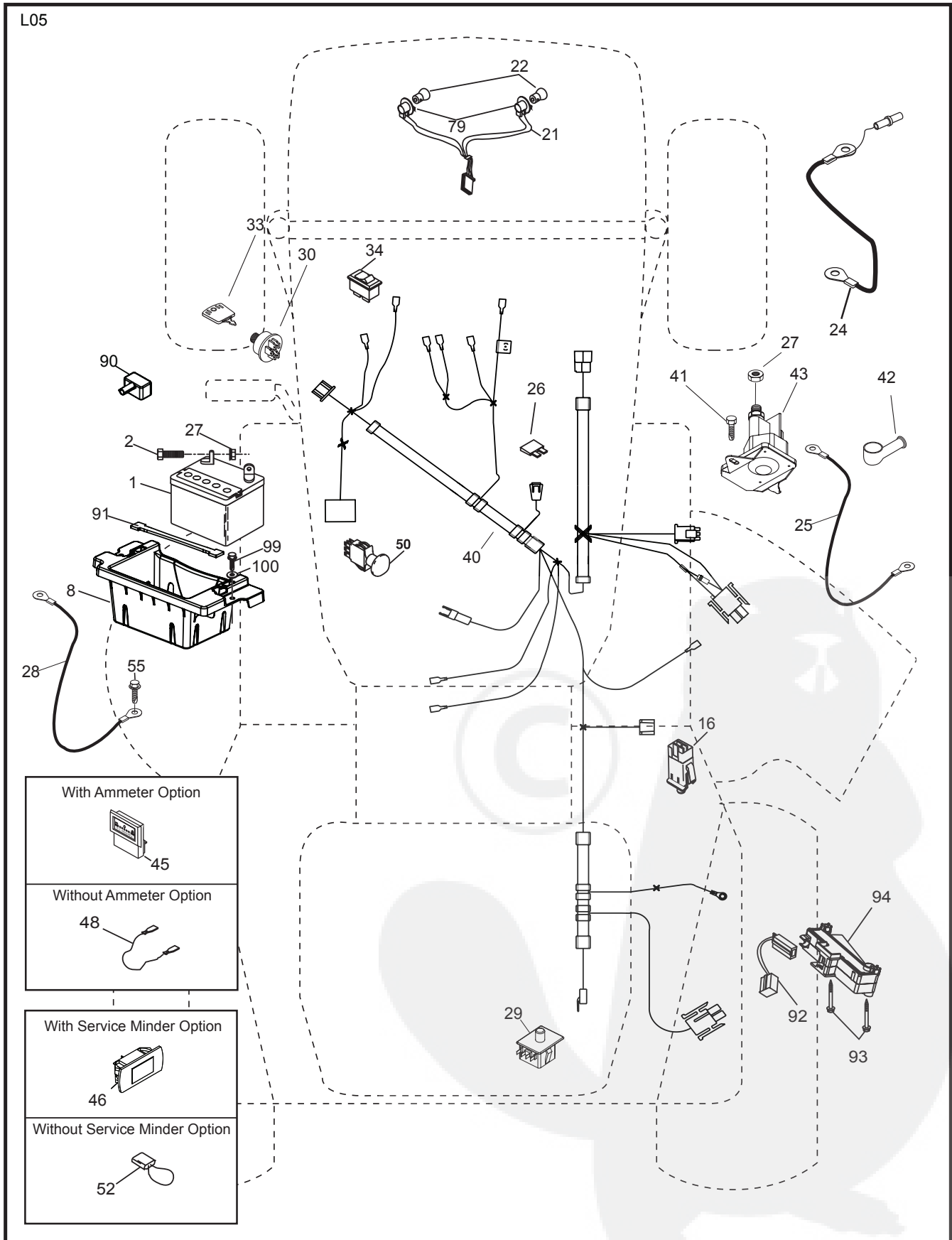

**TRACTOR - MODEL NO. RE20H122 (96011017202), PRODUCT NO. 960 11 01-72
ELECTRICAL**

KEY NO.	PART NO.	DESCRIPTION
1	532 14 49-27	Battery
2	874 76 04-12	Bolt Hex Hd 1/4-20 unc x 3/4
8	532 18 64-91	Box Battery
16	532 17 61-38	Switch Interlock
21	532 18 37-59	Harness Socket Light
22	532 00 41-52	Bulb, Light # 1156
24	532 12 47-80	Cable Battery
25	532 14 61-48	Cable Battery
26	532 17 51-58	Fuse
27	873 51 04-00	Nut Keps Hex 1/4-20 unc
28	532 14 54-91	Cable Ground
29	532 19 27-49	Switch Seat
30	532 19 33-50	Switch Ign
33	532 41 19-35	Key/Chain
34	532 11 07-12	Switch Light/Reset B/B/Red
40	532 19 74-29	Harness Ign
41	871 11 04-08	Bolt Fin Hex 1/4-20 unc x 1/2
42	532 13 15-63	Cover Terminal Red
43	532 19 25-07	Solenoid
48	532 14 08-44	Adapter Ammeter
50	532 17 46-51	Switch PTO
51	532 14 04-05	Ring Retainer PTO
52	532 14 19-40	Protection Loop
55	817 49 05-08	Screw Thdrol 5/16-18 x 1/2
79	532 17 52-42	Socket Asm. Bulb Twistlock
90	532 18 04-49	Cover Terminal Battery
91	532 19 02-70	Strap Battery Mount Front
92	532 19 66-15	Harness Pigtail Console ROS
93	532 19 25-40	Screw Plastite 10-14 x 2.0
94	532 19 18-34	Module Reverse ROS

NOTE: All component dimensions given in U.S. inches
1 inch = 25.4 mm

**TRACTOR - MODEL NO. RE20H122 (96011017202), PRODUCT NO. 960 11 01-72
CHASSIS**

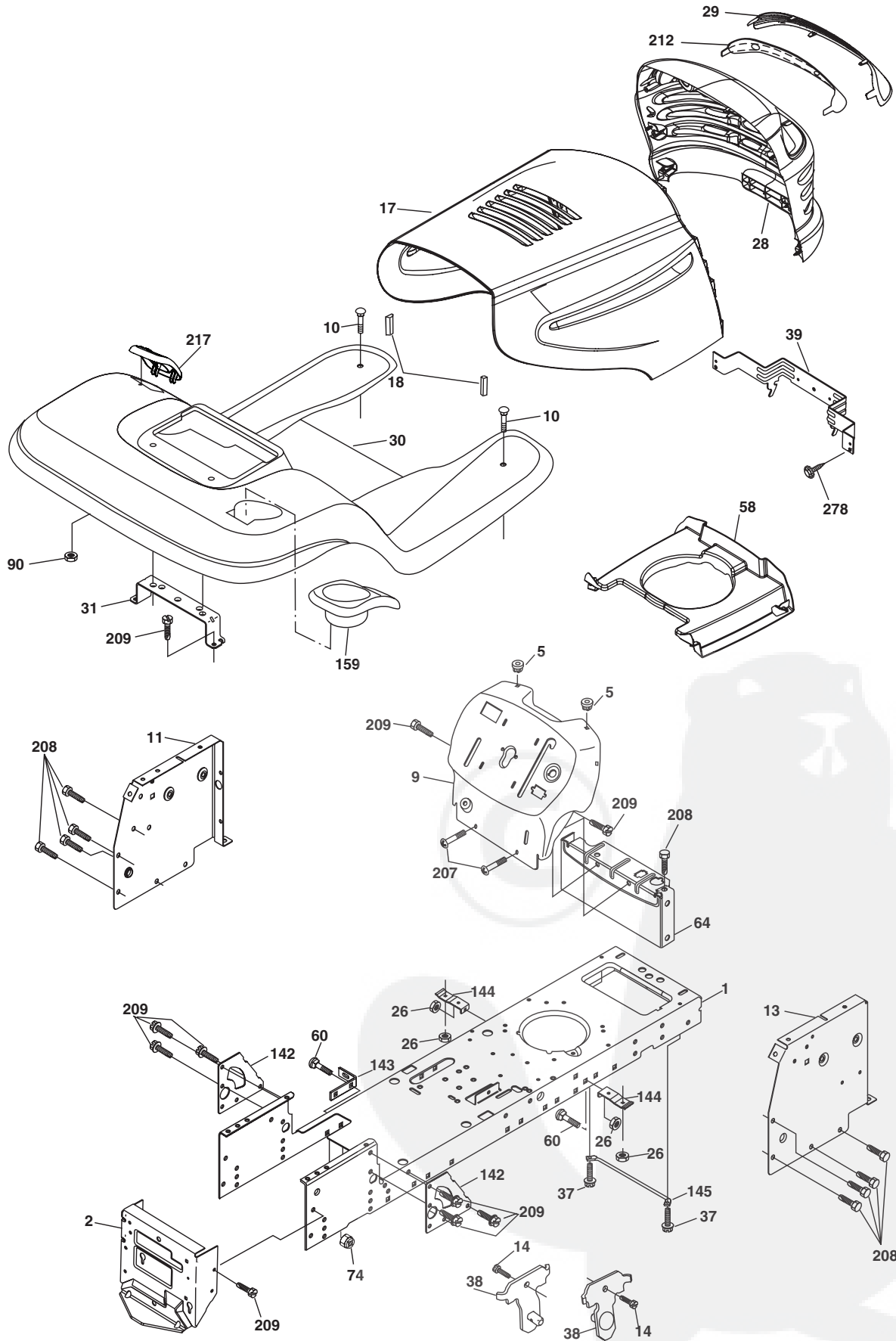

chassis-stlt_elite value_1

**TRACTOR - MODEL NO. RE20H122 (96011017202), PRODUCT NO. 960 11 01-72
CHASSIS**

KEY NO.	PART NO.	DESCRIPTION
1	532 17 46-19	Chassis
2	532 17 65-54	Drawbar
5	532 15 52-72	Bumper Hood/Dash
9	532 19 50-27	Dash P/L
10	872 14 06-08	Bolt Carriage 3/8-16 x 1
11	532 17 49-96	Panel Dash LH
13	532 17 52-55	Panel Dash RH
14	817 49 06-08	Screw Thdrol 3/8-16 x 1/2
17	532 18 67-07	Hood
18	532 18 49-21	Bumper Hood
26	873 80 06-00	Nut Lock Hex w/Ins 3/8-16 unc
28	532 18 35-52	Grille/Lens Asm (Includes Key Nos. 29 and 212)
29	532 18 58-46	Lens Bar
30	532 40 44-27	Fender
31	532 13 99-76	Bracket Fender
37	817 49 05-08	Screw Thdrol 6/16-18 x 1/2 TYT
38	532 17 57-10	Bracket Asm Pivot Mower Rear
39	532 40 78-07	Bracket Pivot Laser LT
58	532 18 44-61	Duct Air
60	872 14 06-06	Bolt RDHD SQNK 3/8-16 unc x 3/4
64	532 15 47-98	Dash Lower STLT
74	873 68 06-00	Nut Crownlock 3/8-16 unc
90	532 12 43-46	Nut Self-THD WSH-HD 1/4
142	532 17 57-02	Plate Reinforcement STLT
143	532 19 66-89	Bracket Swaybar Chassis Notch
144	532 17 55-82	Bracket Footrest
145	532 40 91-67	Rod Pivot Chassis/Hood
159	532 19 46-22	Cupholder
207	817 67 05-08	Screw Thdrol 5/16-18 x 1/2
208	817 67 06-08	Screw Thdrol 3/8-16 x 1/2
209	817 00 06-12	Screw Hex Wsh Thdrol 3/8-16 x 3/4
212	532 18 35-50	Insert Lens Relect
217	532 19 46-19	Console Fuel Window
278	532 41 63-58	Screw #10 x 0.750. BOS

NOTE: All component dimensions given in U.S. inches
1 inch = 25.4 mm

TRACTOR - MODEL NO. RE20H122 (96011017202), PRODUCT NO. 960 11 01-72
DRIVE

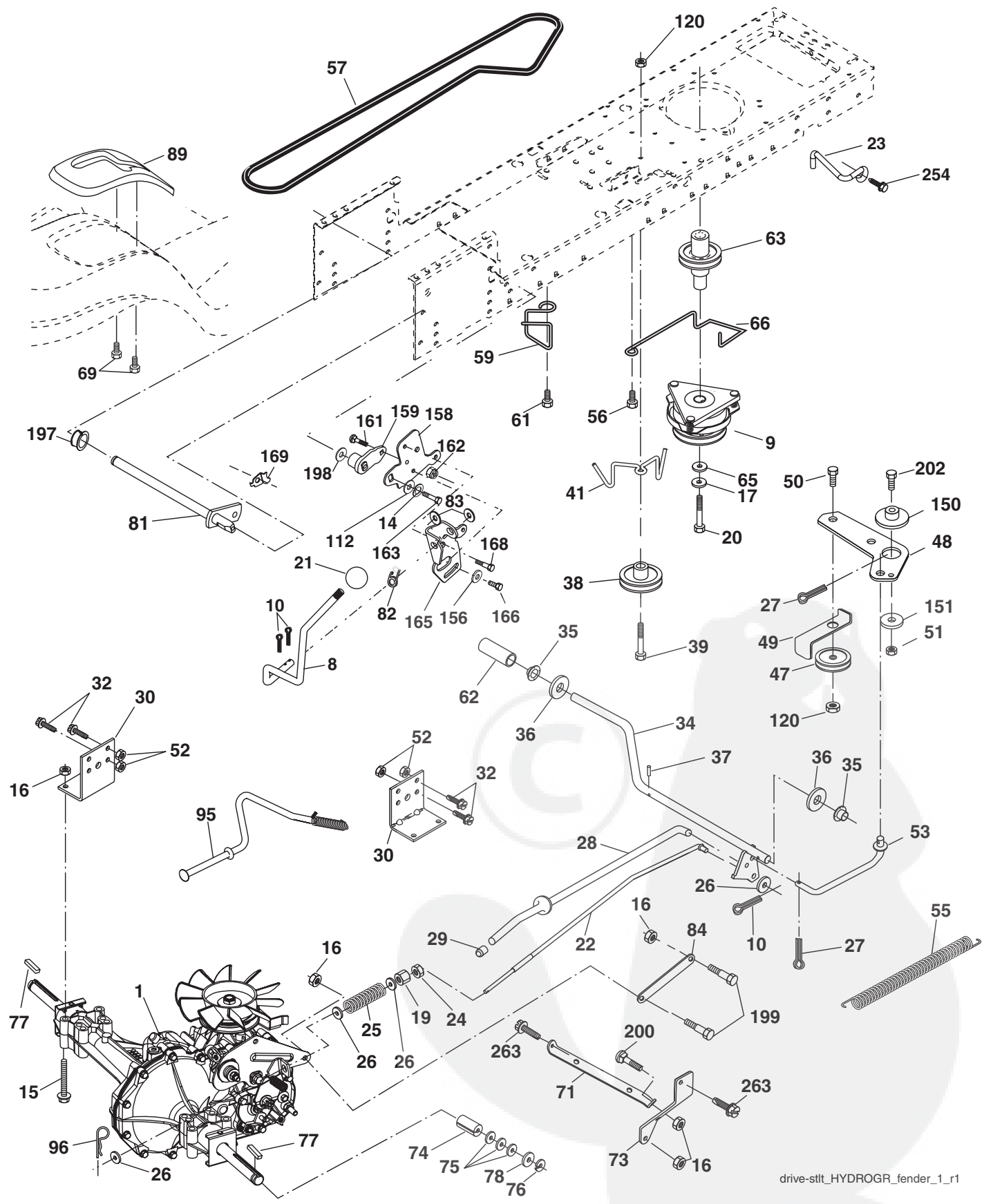

drive-sttt_HYDROGR_fender_1_r1

**TRACTOR - MODEL NO. RE20H122 (96011017202), PRODUCT NO. 960 11 01-72
DRIVE**

KEY NO.	PART NO.	DESCRIPTION	KEY NO.	PART NO.	DESCRIPTION
1	-----	Transaxle, Hydro Gear 314-0510 (Order Parts From Transaxle Manufacturer)	63	532 17 46-07	Pulley, Engine
8	532 19 25-02	Rod Shift Fender	64	532 17 39-37	Bolt, Hex 7/16-20 x 4
9	532 17 93-34	Clutch Electric	65	810 04 07-00	Washer
10	876 02 04-16	Pin Cotter 1/8 x 1 CAD	66	532 15 47-78	Keeper Belt Engine Hydro
14	810 04 04-00	Washer Lock Hvy Helical	69	532 14 24-32	Screw Hex Wsh Hi-Lo 1/4-1/2
15	874 49 05-44	Bolt Hex Flghd 5/16-18 Gr. 5	71	532 16 91-83	Strap Torque LH Hydro
16	873 80 05-00	Nut Lock Hex w/Ins. 5/16-18 unc	73	532 16 91-82	Strap Torque RH Hydro
19	873 80 06-00	Nut Lock Hex w/Wsh 3/8-16 unc	74	532 13 70-57	Spacer, Axle
17	532 12 61-97	Washer 1-1/2 OD x 15/32 ID x 250	75	532 12 17-49	Washer 25/32 x 1-1/4 x 16 Ga.
21	532 14 08-45	Knob	76	812 00 00-01	E-Ring
22	532 16 94-98	Rod, Brake Hydro	77	532 12 35-83	Key, Square
23	532 19 07-36	Bracket Asm. Anti-Rot	78	532 12 17-48	Washer 25/32 x 1-5/8 x 16 Ga.
24	873 35 06-00	Locknut	81	532 16 55-96	Shaft Asm. Cross Hydro
25	532 10 68-88	Spring, Brake Rod	82	532 16 57-11	Spring Torsion T/A
26	819 13 13-16	Washer	83	819 17 12-16	Washer 17/32 x 3/4 x 16 Ga.
27	876 02 04-12	Pin Cotter 1/8 x 3/4 CAD.	84	532 16 95-94	Link Transaxle
28	532 17 57-65	Rod, Parking Brake	89	532 19 57-46	Console, Shift
29	532 07 16-73	Cap, Parking Brake	95	532 17 02-01	Control Asm. Bypass Hydro
30	532 16 95-92	Bracket, Transaxle	96	532 12 47-88	Retainer Spring 1" Zinc/Cad
32	874 76 05-12	Bolt Hex Hd 5/16-18 unc x 3/4	112	819 09 12-10	Washer 9/32 x 3/4 x 10 Ga.
34	532 17 55-78	Shaft, Foot Pedal Nibbed	120	873 90 06-00	Nut Lock 3/8-16
35	532 12 01-83	Bearing, Nylon	150	532 17 54-56	Spacer Retainer
36	819 21 16-16	Washer	151	819 13 32-10	Washer 13/32 x 2 x 10 Ga.
37	532 12 49-63	Pin, Roll	156	532 16 60-02	Washer Srrtd 5/16 ID x 1.125
38	532 17 91-14	Pulley, Idler, Flat Composite	158	532 16 55-89	Bracket Shift Mount
39	872 11 06-22	Bolt RDHD 3/8-16 unc x 2-3/4 Gr. 5	159	532 18 39-00	Hub Tapered Flange Shift Lt
41	532 17 55-56	Keeper, Belt Idler Fool-Proof	161	872 14 04-06	Bolt Rdhd Sqnk 1/4-20 x 3/4 Gr. 5
47	532 12 77-83	Pulley, Idler, V-Groove	162	873 68 04-00	Nut Crownlock 1/4-20 unc
48	532 15 44-07	Bellcrank Clutch Grnd Drv Stl	163	874 78 04-16	Bolt Hex Fin 1/4-20 unc x 1 Gr. 5
49	532 12 32-05	Retainer, Belt	165	532 16 56-23	Bracket Pivot Lever
50	872 11 06-12	Bolt Carr Sh 3/8-16 x 1-1/2	166	817 49 05-10	Screw 5/16-18 x 5/8
51	873 68 06-00	Nut	168	532 16 54-92	Bolt Shoulder 5/16-18 x .561
52	873 68 05-00	Nut Crown Lock 5/16-18	169	532 16 55-80	Plate Fastening Lt
53	532 19 96-52	Link, Clutch	197	532 16 96-13	Nyliner Snap-In 5/8 ID
55	532 10 57-09	Spring, Return, Clutch	198	532 16 95-93	Washer Nyliner 7/8 ID x .105
56	817 06 06-20	Screw 3/8-16 x 1-1/4	199	532 16 96-12	Bolt Shoulder 5/16-18 unc
57	532 14 02-94	V-Belt, Ground Drive	200	872 14 05-08	Bolt Rdhd Sq Neck 5/16-18 unc x 1
59	532 16 96-91	Keeper, Center Span	202	872 11 06-14	Bolt RDHD 3/8-16 unc x 1-3/4 Gr. 5
61	817 12 06-14	Screw 3/8-16 x .875	254	817 00 06-16	Screw 3/8-16 x 1
62	532 12 48-72	Cover, Pedal	263	817 00 06-12	Screw 3/8-16 x 3/4

NOTE: All component dimensions given in U.S. inches
1 inch = 25.4 mm

TRACTOR - MODEL NO. RE20H122 (96011017202), PRODUCT NO. 960 11 01-72
STEERING ASSEMBLY

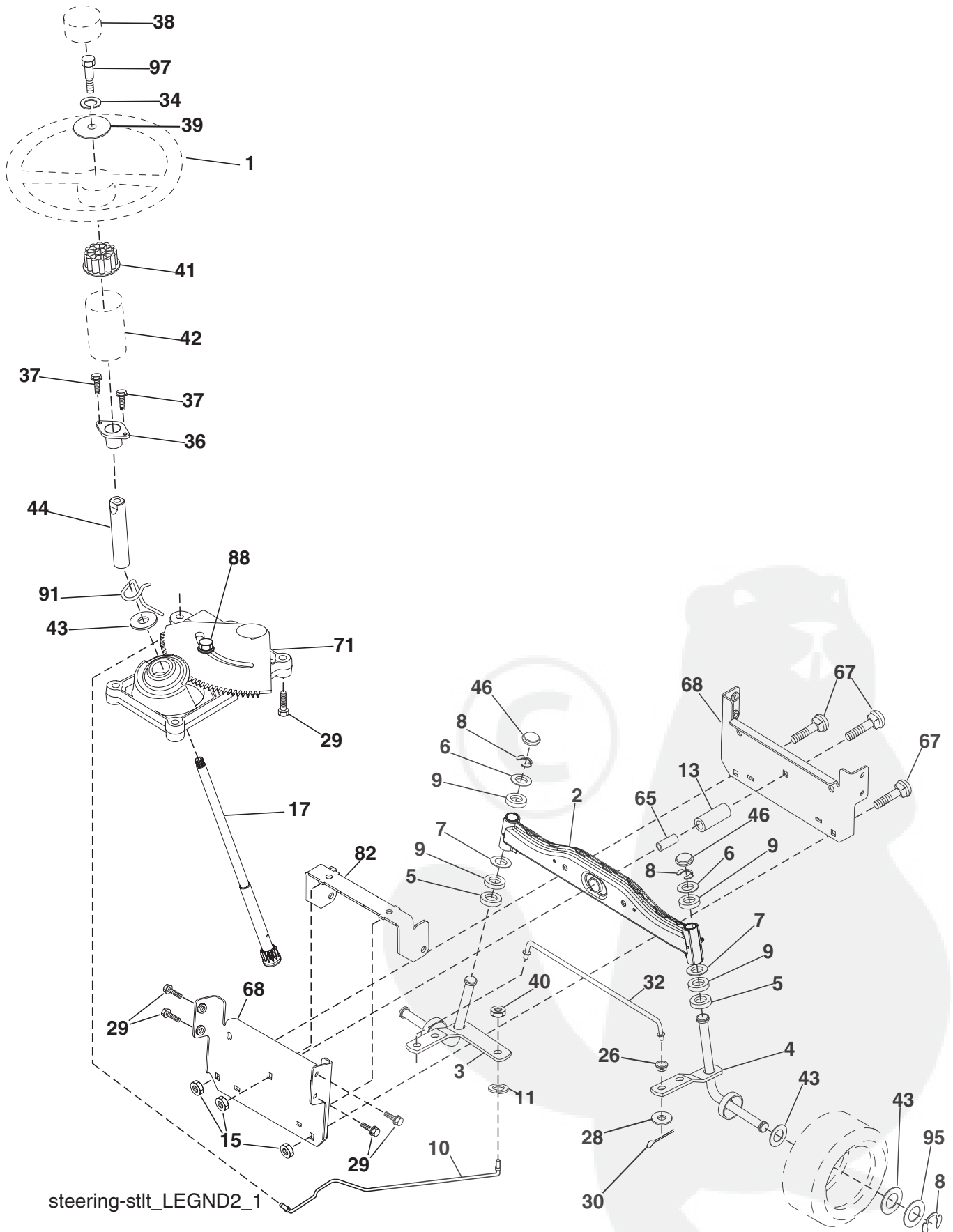

**TRACTOR - MODEL NO. RE20H122 (96011017202), PRODUCT NO. 960 11 01-72
STEERING ASSEMBLY**

KEY NO.	PART NO.	DESCRIPTION
1	532 19 45-95	Wheel Steering
2	532 18 47-06	Axle Casting Iron Lt
3	532 16 98-40	Spindle Asm LH
4	532 16 98-39	Spindle Asm RH
5	532 12 49-31	Washer Thrust .75 x 1.230
6	532 12 17-48	Washer 25/32 x 1-5/8 x 16 Ga.
8	812 00 00-29	Ring Clip #t5304-75
10	532 17 51-21	Draglink
11	810 04 06-00	Washer Lock Hvy Hlcl Spr 3/8
13	532 13 65-18	Spacer Bearing Axle Front
15	532 14 52-12	Nut Hex Flange Lock
17	532 19 07-53	Shaft Asm Strg
26	532 12 68-47	Bushing Link Drag
28	819 13 14-16	Washer 13/32 x 7/8 x 16 Ga.
29	817 00 06-12	Screw 3/8-16 x 3/4
30	876 02 04-12	Pin Cotter 1/8 x 3/4
32	532 19 27-57	Rod Asm Tie
34	810 04 05-00	Washer Lock Hvy Hlcl Spr. 5/16
36	532 15 50-99	Bushing Strg
37	532 15 29-27	Screw TT #32.5 x 5 x 3/8 Flange
38	532 19 46-03	Insert Cap Strg Wh
39	819 11 38-12	Washer 11/32 ID x 2-3/8 OD 12 Ga.
40	873 54 06-00	Nut Crownlock 3/8-24
41	532 18 67-37	Adapter Wheel Strg
42	532 16 96-33	Boot Steering
43	532 12 17-49	Washer 25/32 x 1 1/4 x 16 Ga.
44	532 19 07-52	Extension Steering
46	532 12 12-32	Cap Spindle Fr Top Blk
65	532 41 47-36	Spacer Axle Brace
67	872 11 06-18	Bolt Rdhd Sqnk 3/8-16 unc x 2-1/4
68	532 16 98-27	Brace Axle
71	532 17 51-46	Steering Asm.
82	532 19 99-78	Bracket Susp Chassis Front
87	532 17 39-66	Washer Flat .781 x 1-1/2 x .14
88	532 17 51-18	Bolt Shoulder 7/16-20
91	532 17 55-53	Clip Steering
95	532 18 89-67	Washer Harden .739 x 1.63 x 060
97	874 78 05-64	Bolt 5/16-18 unc x 4"L Gr. 5

NOTE: All component dimensions given in U.S. inches
1 inch = 25.4 mm

**TRACTOR - MODEL NO. RE20H122 (96011017202), PRODUCT NO. 960 11 01-72
SEAT ASSEMBLY**

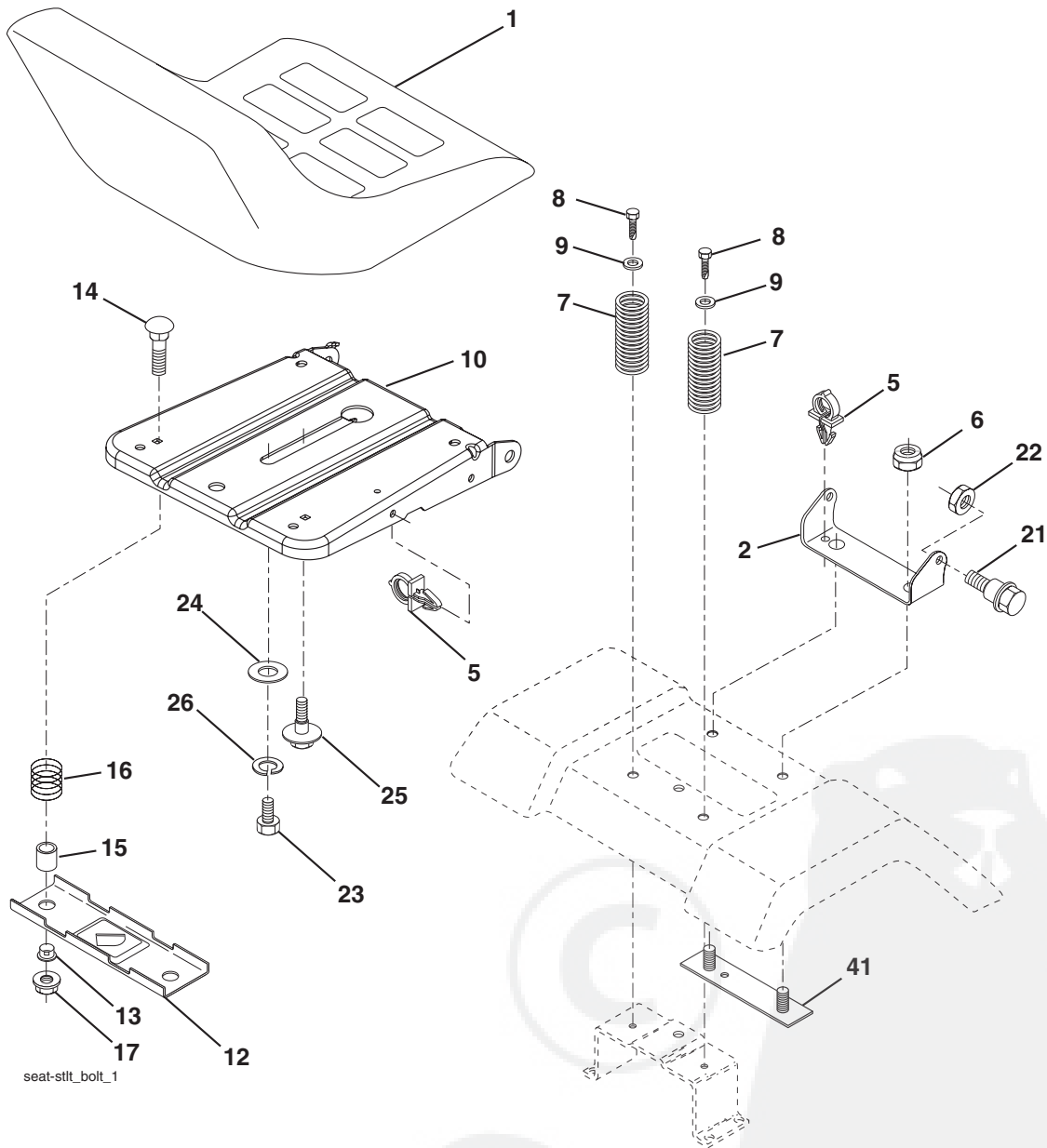

seat-stlt_bolt_1

KEY NO.	PART NO.	DESCRIPTION
1	532 40 10-43	Seat
2	532 14 05-51	Bracket Pivot Seat
5	532 14 50-06	Clip Push-In Hinged
6	873 80 06-00	Nut Lock Hex w/Ins. 3/8-16 unc
7	532 12 41-81	Spring Seat Cprsn 2 250 Blk Zi
8	817 00 06-16	Screw 3/8-16 x 1
9	819 13 16-14	Washer 13/32 x 1 x 14 Ga.
10	532 19 55-30	Pan Seat
12	532 17 46-48	Bracket Mounting Switch
13	532 12 12-48	Bushing Snap Blk Nyl 50 Id
14	872 05 04-12	Bolt Rdhd Sht Nk 1/4-20 x 1-1/2

KEY NO.	PART NO.	DESCRIPTION
15	532 12 12-49	Spacer Split 28 x 88 Zinc
16	532 12 37-40	Spring Cprsn Blk Pnt
17	532 12 39-76	Nut Lock 1/4 Lge Flg Gr. 5 Zinc
21	532 17 18-52	Bolt Shoulder 5/16-18 unc-2A
22	873 80 05-00	Nut Lock Hx w/Ins 5/16-18 unc
23	871 11 08-14	Bolt Hex
24	819 17 19-12	Washer 17/32 x 1-3/16 x 12 Ga.
25	532 12 70-18	Bolt Shoulder 5/16-18 x .62
26	810 04 08-00	Washer Lock Hvy HLCL SPR 1/2
41	532 14 06-75	Strap Asm.

NOTE: All component dimensions given in U.S. inches
1 inch = 25.4 mm

TRACTOR - MODEL NO. RE20H122 (96011017202), PRODUCT NO. 960 11 01-72 ENGINE

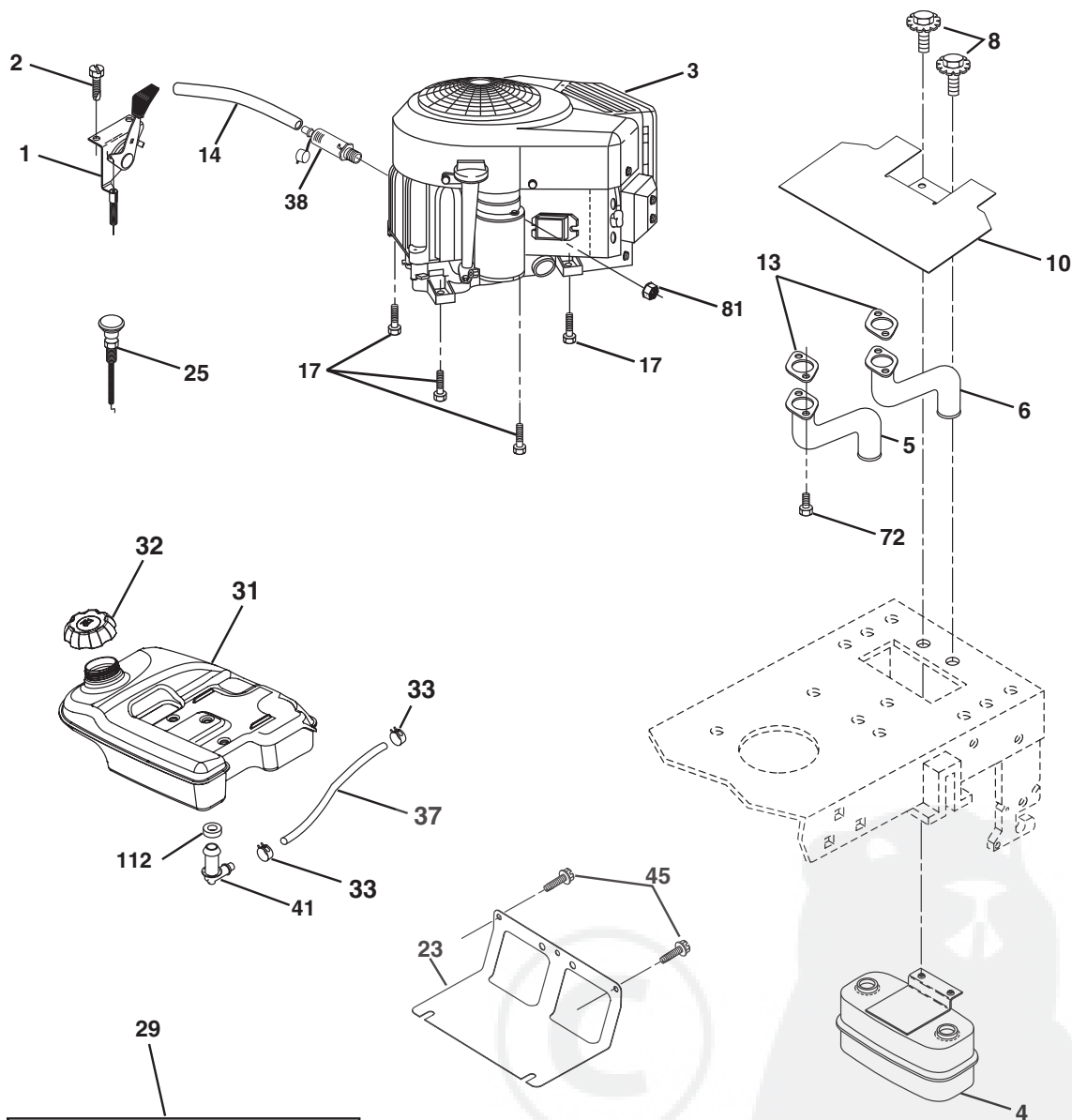

OPTIONAL EQUIPMENT
Spark Arrester

engine-stlt_bs-2_1

KEY NO.	PART NO.	DESCRIPTION
1	532 17 07-71	Control Throt
2	817 72 04-08	Screw Thd Cut 1/4-20 x 1/2
3	-----	Engine Briggs & Stratton Model 406777 (Order parts from engine manufacturer)
4	532 14 97-23	Muffler Twin Lo-Twin
5	532 15 99-55	Tube, Exhaust LH
6	532 16 05-89	Tube, Exhaust RH
8	532 17 18-77	Bolt 5/16-18 unc x 3/4 w/Sems
10	532 14 66-29	Shield Heat Muffler
13	532 16 53-91	Gasket Muffler
14	532 14 84-56	Tube Drain Oil Easy
17	817 06 06-24	Screw, Thdrol 3/8-16 x 1-1/2 Tytt
23	532 16 98-37	Shield Brn/Dbr Guard

KEY NO.	PART NO.	DESCRIPTION
25	532 19 17-17	Choke Control
29	532 13 71-80	Kit Spark Arrester
31	532 17 09-22	Tank Fuel
32	532 18 29-02	Cap Asm Fuel
33	532 12 34-87	Clamp Hose Blk
37	532 14 21-58	Line Fuel
38	532 18 16-54	Plug Drain Oil Easy
41	532 13 92-77	Stem Tank Fuel
45	817 00 06-12	Screw Hex Wsh Thdrol 3/8-16
72	532 18 39-06	Screw Socket Head 5/16-18 x 1
81	873 51 04-00	Nut Keps Hex 1/4-20 unc
112	532 12 49-52	Bushing

NOTE: All component dimensions given in U.S. inches
1 inch = 25.4 mm

**TRACTOR - MODEL NO. RE20H122 (96011017202), PRODUCT NO. 960 11 01-72
MOWER DECK**

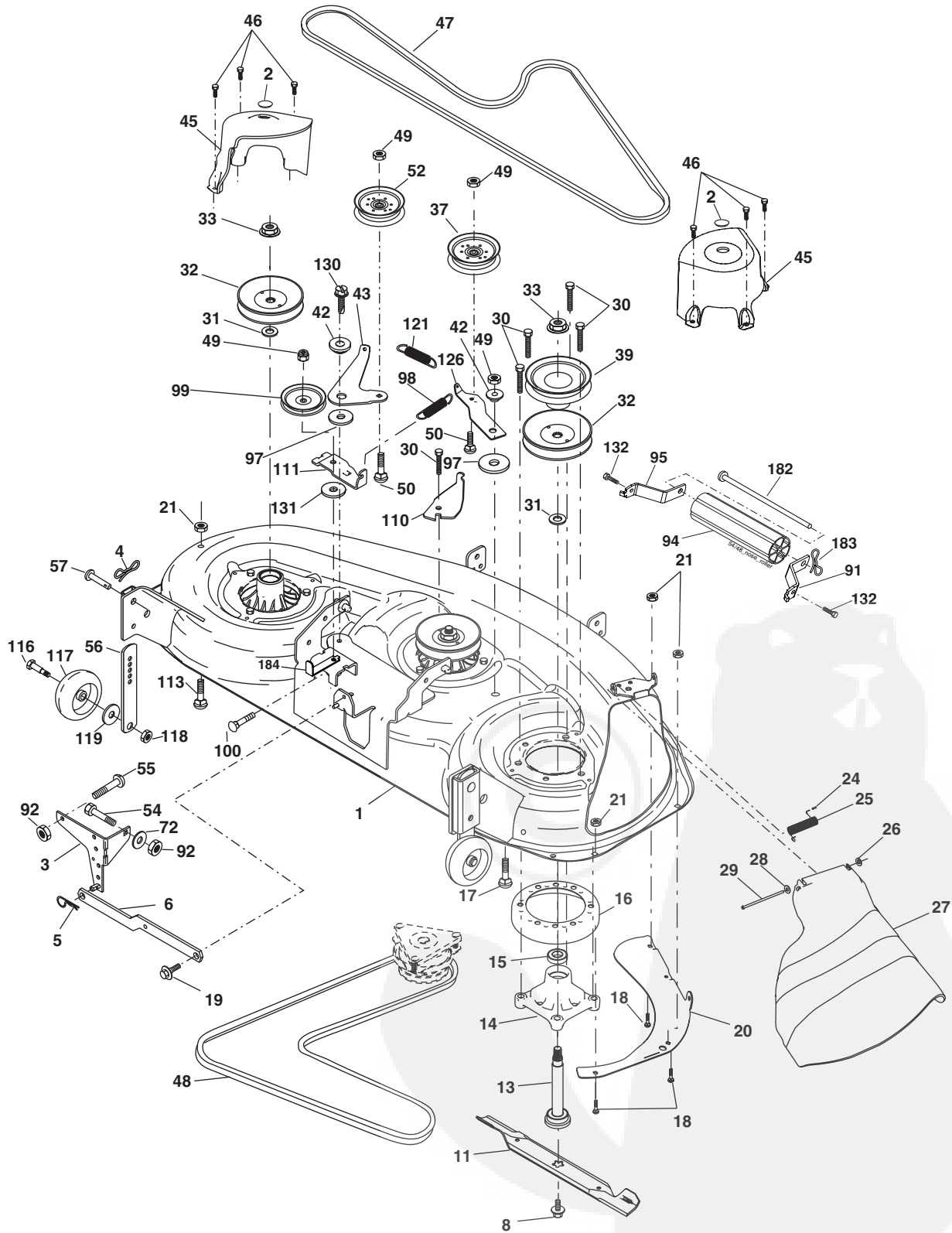

mower_deck.48lowcost_stlt_3_r1

**TRACTOR - MODEL NO. RE20H122 (96011017202), PRODUCT NO. 960 11 01-72
MOWER DECK**

KEY NO.	PART NO.	DESCRIPTION	KEY NO.	PART NO.	DESCRIPTION
1	532 18 03-59	Deck Weldment Mower 48	55	872 14 06-08	Bolt RDHD SQNK 3/8-16 unc x 1
2	532 17 83-45	Plug Hole Mandrel	56	532 15 59-86	Bar Pnt Adjusting Wheel Gauge
3	532 13 80-17	Bracket Asm., Sway Bar	57	532 15 69-41	Pin Head Rivet
4	532 19 42-08	Pin Cotter 5/16 Bowtie Lock	72	819 13 13-12	Washer 13/32 X 13/16 x 12 Ga.
5	532 12 46-70	Retainer Spring	91	532 18 05-35	Bracket, Asm Noseroller, RH 48
6	532 17 80-24	Bar Sway Deck	92	873 80 06-00	Nut Lock Hex w/lins 3/8-16 unc
8	532 17 43-65	Bolt, 7/16 Asm. Blade	94	532 17 60-66	Roller, Nose 48"
11	532 18 00-54	Blade	95	532 18 05-34	Bracket, Asm Noseroller LH 48
13	532 17 51-47	Shaft Asm.	97	532 17 85-15	Washer Hardened
14	532 17 43-58	Housing Mandrel 48"	98	532 17 94-79	Spring Primary Drive
15	532 11 04-85	Bearing, Ball, Mandrel	99	532 19 31-95	Pulley Idler "V"
16	532 17 44-93	Stripper, Mower	100	872 11 06-16	Bolt RDHD Sqnk 3/8-16 unc x 2
17	872 11 06-10	Bolt Rdhd Sq Neck 3/8-16 x 1.25	110	532 17 50-16	Arm Spring Secondary
18	872 14 05-05	Bolt, Carriage 5/16-18 x 5/8	111	532 17 46-10	Arm Spring Fixed Tension 48"
19	532 13 28-27	Bolt, Hex Head, Shoulder 5/16-18	113	872 11 05-06	Bolt Rdhd Sqnk 5/16-18 x 3/4
20	532 17 43-78	Baffle, Vortex Mower	116	532 19 34-06	Bolt, Shoulder
21	873 68 05-00	Nut, Crownlock 5/16-18 unc	117	532 17 48-73	Gauge Wheel
24	532 10 53-04	Cap, Sleeve	118	873 90 06-00	Nut Lock Flg 3/8-16 unc
25	532 17 81-02	Spring, Torsion	119	819 13 20-12	Washer 13/32 x 1-1/4 x 12 Ga.
26	532 11 04-52	Nut, Push	121	532 17 43-71	Spring Secondary Drive
27	532 18 17-07	Shield, Deflector Mower	126	532 17 43-72	Arm, Idler, Primary Deck
28	819 11 10-16	Washer 11/32 x 5/8 x 16 Ga.	130	817 00 06-16	Screw 3/8-16 x 1.0
29	532 13 14-91	Rod, Hinge	131	819 13 16-06	Washer 13/32 x 1 x 6 Ga.
30	532 17 39-84	Screw, Thdroll, Washer Head	132	874 76 05-16	Bolt, Fin, Hex 5/16-18 x 1.0
31	532 18 76-90	Washer, Spacer	180	873 80 05-00	Nut Lock 5/16-18
32	532 15 35-35	Pulley, Mandrel	182	532 17 91-27	Rod Roller Nose
33	532 40 02-34	Nut, Flg. Top Lock	183	532 19 42-09	Pin Cotter 7/16 Bow Tie Lock
37	532 19 31-97	Pulley, Idler, Flat	184	532 17 39-79	Keeper Belt Idler
39	532 17 43-75	Pulley, Idler, Driven	--	532 17 43-57	Mandrel Assembly (Includes hous- ing, shaft assembly, and bear- ing only - pulley/nut/washer and blade bolt/washers not included)
42	532 16 57-23	Spacer, Retainer	--	532 40 42-05	Replacement Mower, Complete (Std deck-order separately nose roller components key nos. 90, 91, 94, 95, 180, 182, 183)
43	532 17 43-73	Arm, Idler Secondary			
45	532 18 08-06	Cover, Mandrel Deck			
46	532 13 77-29	Screw, Thdroll. 1/4-20 x 5/8			
47	532 18 08-08	V-Belt, Mower, Secondary			
48	532 17 43-68	V-Belt, Mower, Primary			
49	873 90 06-00	Nut 3/8-16 unc			
50	872 11 06-12	Bolt, Carriage 3/8-16 x 1-1/2 Gr. 5			
52	532 19 31-98	Pulley Idler Flat 46 Pri. Drive			
54	874 78 06-16	Bolt Fin Hex 3/8-16 unc x 1 Gr. 5			

NOTE: All component dimensions given in U.S. inches
1 inch = 25.4 mm

TRACTOR - MODEL NO. RE20H122 (96011017202), PRODUCT NO. 960 11 01-72
MOWER LIFT

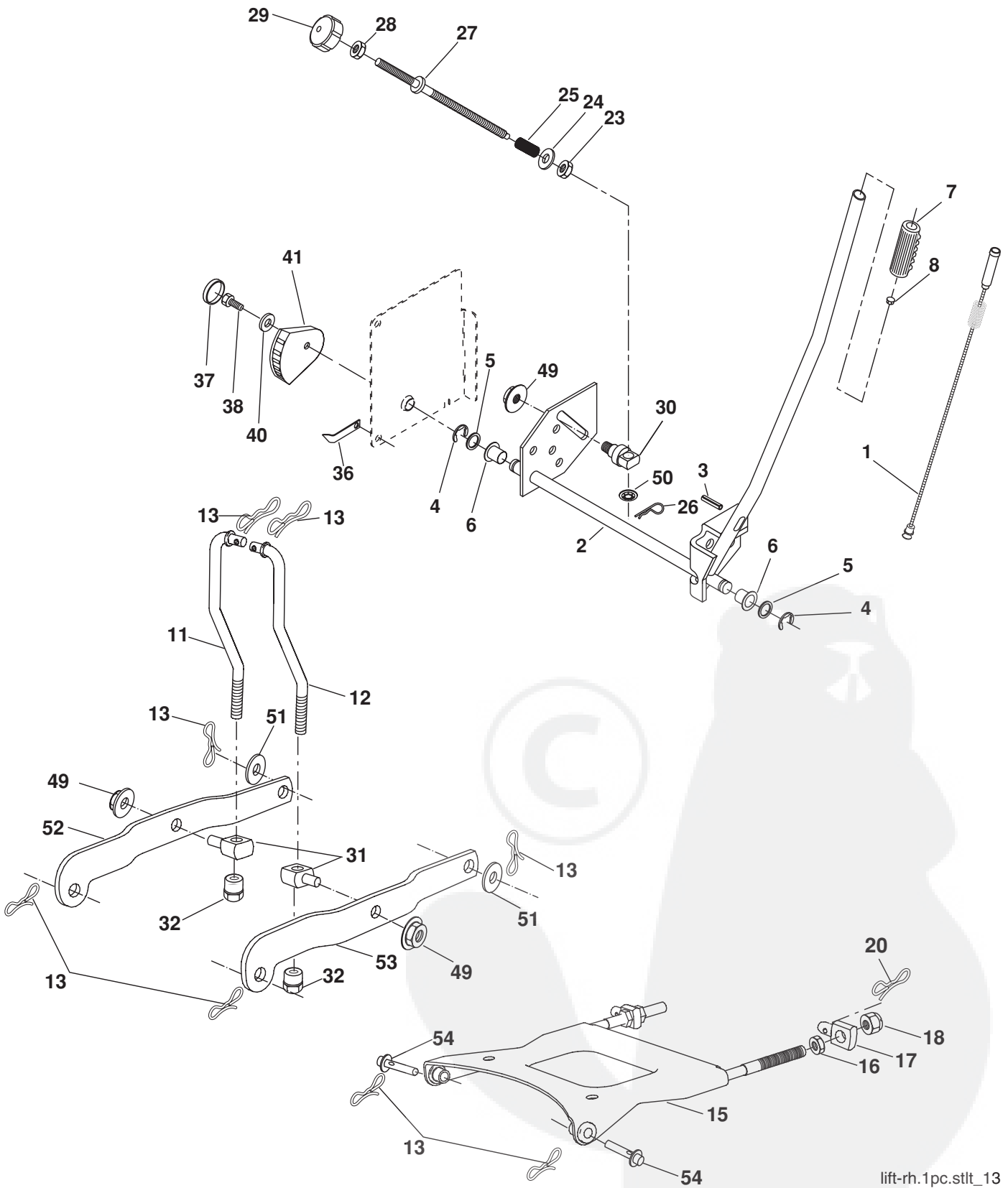

lift-rh.1pc.stlt_13

**TRACTOR - MODEL NO. RE20H122 (96011017202), PRODUCT NO. 960 11 01-72
MOWER LIFT**

KEY NO.	PART NO.	DESCRIPTION
1	532 19 84-17	Wire Asm Inner/Spring w/Plunger YT
2	532 19 80-70	Shaft Asm Lift RH w/Inf
3	532 18 88-22	Pin Groove 1 500 Zinc
4	812 00 00-02	E Ring #5133-62
5	819 21 16-21	Washer 21/32 x 1 x 21 Ga.
6	532 12 01-83	Bearing Nylon Blk 629 Id
7	532 12 56-31	Grip Handle Fluted Blk
8	532 12 45-26	Button Plunger
11	532 17 53-70	Link Lift LH
12	532 17 53-71	Link Lift RH
13	532 12 46-70	Retainer Spring
15	532 17 55-62	Plate Asm Susp Front
16	873 35 08-00	Nut Jam Hex 1/2-13 unc
17	532 17 56-89	Trunnion
18	873 80 08-00	Nut Lock w/Wsh 1/2-13 unc
20	532 19 42-09	Pin Cotter 7/16 Bow Tie Lock
23	532 11 08-07	Nut Special
24	819 13 10-16	Washer 13/32 x 5/8 x 16 Ga.
25	532 12 48-74	Spring
26	532 16 94-84	Retainer Clip
27	532 12 69-71	Rod Adj Lift
28	873 35 06-00	Nut Hex Jam 3/8-16 unc
29	532 13 80-57	Knob Inf 3/8-16 unc Blk w/Sym
30	532 15 02-33	Trunnion Infin Height
31	532 17 62-05	Trunnion
32	532 17 59-94	Nut Lift Link 7/16-20
36	532 15 50-97	Indicator Height STLT
37	532 12 39-35	Plug Hole Blk 1.485/1.515 Dia.
38	817 06 05-16	Screw 5/16-18 x 1
40	819 11 24-10	Washer 11/32 x 1-1/2 10 Ga.
41	532 15 50-98	Scale Ind. Height Blk.
49	532 14 52-12	Nut Hex Flange Lock
50	532 11 04-52	Nut, Push Phos & Oil
51	819 17 14-16	Washer 17/32 x 7/8 x 16 Ga.
52	532 17 53-78	Arm Susp. Rear LH
53	532 17 58-02	Arm Susp. Rear RH
54	532 17 55-60	Pin Flange

NOTE: All component dimensions given in U.S. inches
1 inch = 25.4 mm

**TRACTOR - MODEL NO. RE20H122 (96011017202), PRODUCT NO. 960 11 01-72
DECALS**

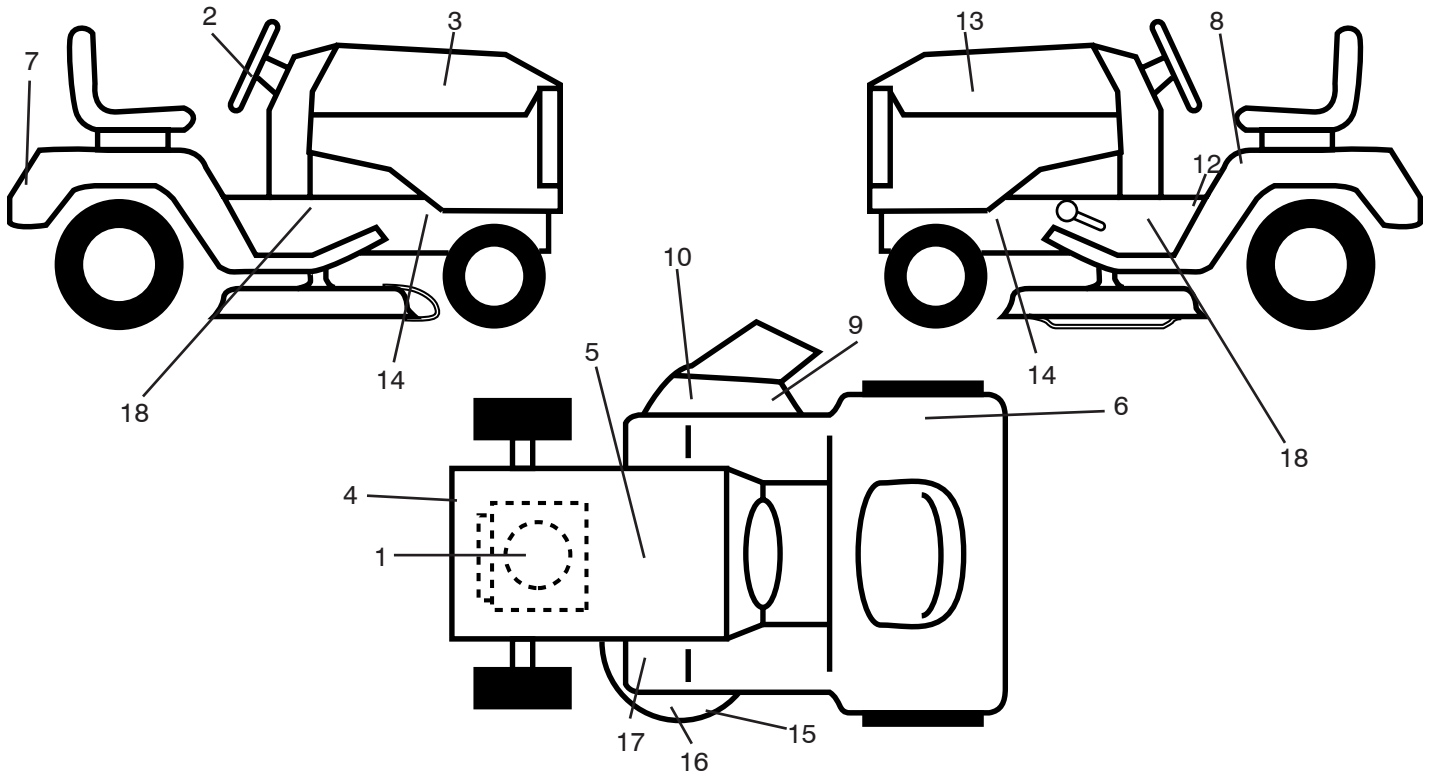

KEY NO.	PART NO.	DESCRIPTION	KEY NO.	PART NO.	DESCRIPTION
1	532 40 88-38	Decal, Engine	16	532 13 49-99	Decal, Mower Enviro
2	532 18 66-60	Decal, Ins. Strg. Whl.	17	532 15 97-37	Decal, Brake/Clutch Symbol LT
3	532 18 76-20	Decal, Hood RH	18	532 19 10-84	Decal, Chassis
4	532 19 68-41	Decal, Warning Eng. Syms.	--	532 18 82-52	Decal, Footrest Pad LH
5	532 14 50-05	Decal, Btry DNGR/PSN P/L Sym.	--	532 18 82-53	Decal, Footrest Pad RH
6	532 18 04-33	Decal, 105 DBA	--	532 16 25-98	Decal, Drawbar Load Limit
7	532 18 11-46	Decal, Fender	--	532 13 83-11	Decal, Lift Handle
8	532 40 03-89	Decal, Warning Syms. CE	--	532 16 69-60	Decal, By Pass Hydro
9	532 19 63-57	Decal, Deflect Warning Cutfinger	--	532 40 23-60	Manual Oper. Euro.
10	532 18 21-66	Decal, Mower Cutfinger	--	532 40 23-61	Manual Oper. Scan.
12	532 14 08-37	Decal, Saddle Brake Parking	--	532 41 69-19	Manual Parts
13	532 18 76-21	Decal, Hood LH	--	532 41 19-89	Manual Oper. E-Bloc
14	532 15 97-36	Decal, Chassis Hot Muffler	--	532 41 19-90	Manual Oper. Baltic
15	532 17 52-91	Decal, V-Belt			

WHEELS AND TIRES

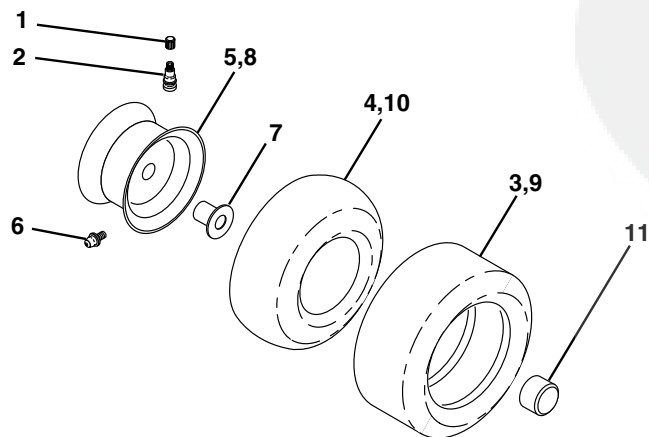

KEY NO.	PART NO.	DESCRIPTION
1	532 05 91-92	Cap Valve Tire
2	532 06 51-39	Stem Valve
3	532 10 62-22	Tire F Tm 15 x 6 0 - 6 Service
4	532 05 99-04	Tube Front (Service Item Only)
5	532 18 33-37	Rim Asm 6" Front Service
6	532 12 49-57	Fitting Grease (Front Wheel Only)
7	532 12 49-59	Bearing Flange (Front Wheel Only)
8	532 18 33-38	Rim Asm 8" Rear Service
9	532 13 84-68	Tire R. TS 20 x 8-8 C. Service
10	532 12 49-26	Tube Rear (Service Item Only)
11	532 17 50-39	Cap, Hub Axle Blk 1.50 x 1.00
--	532 14 43-34	Tire, Sealant (10 oz. Tube)

NOTE: All component dimensions given in U.S. inches
1 inch = 25.4 mm

SERVICE NOTES





Rally