

REPAIR PARTS MANUAL
MODEL NO. LZ145H107AK (96011017703)
Lawn Tractor

LAZER[®]

HOW TO USE THIS MANUAL

This manual is designed to provide the customer with a means to identify the parts on his/her tractor when ordering repair parts. The illustrations may or may not represent the actual assemblies; therefore, it is not recommended to use this manual as a guide to assemble or disassemble the tractor. Some hardware and parts are drawn larger in order to more readily identify them.

Each tractor has its own model number.

The model number for your tractor can be found on the fender under the seat.

When ordering parts, always give the following information:

- Product - "Lawn Tractor"
- Model Number - "LZ145H107AK" (96011017703)
- Part Number
- Part Description

TABLE OF CONTENTS

SCHEMATIC	3
ELECTRICAL.....	4-5
CHASSIS AND ENCLOSURES.....	6-7
DRIVE.....	8-9
STEERING WHEEL	10-11
ENGINE.....	12-13
SEAT	14
DECALS.....	15
MOWER DECK	16-17
MOWER LIFT	18-19

TRACTOR-MODEL NO. LZ145H107AK(96011017703), PRODUCT NO. 960 11 01-77 SCHEMATIC

SCH03

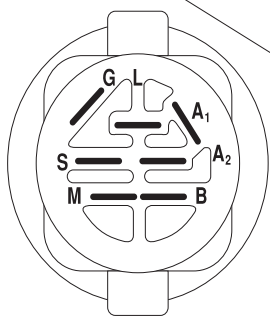
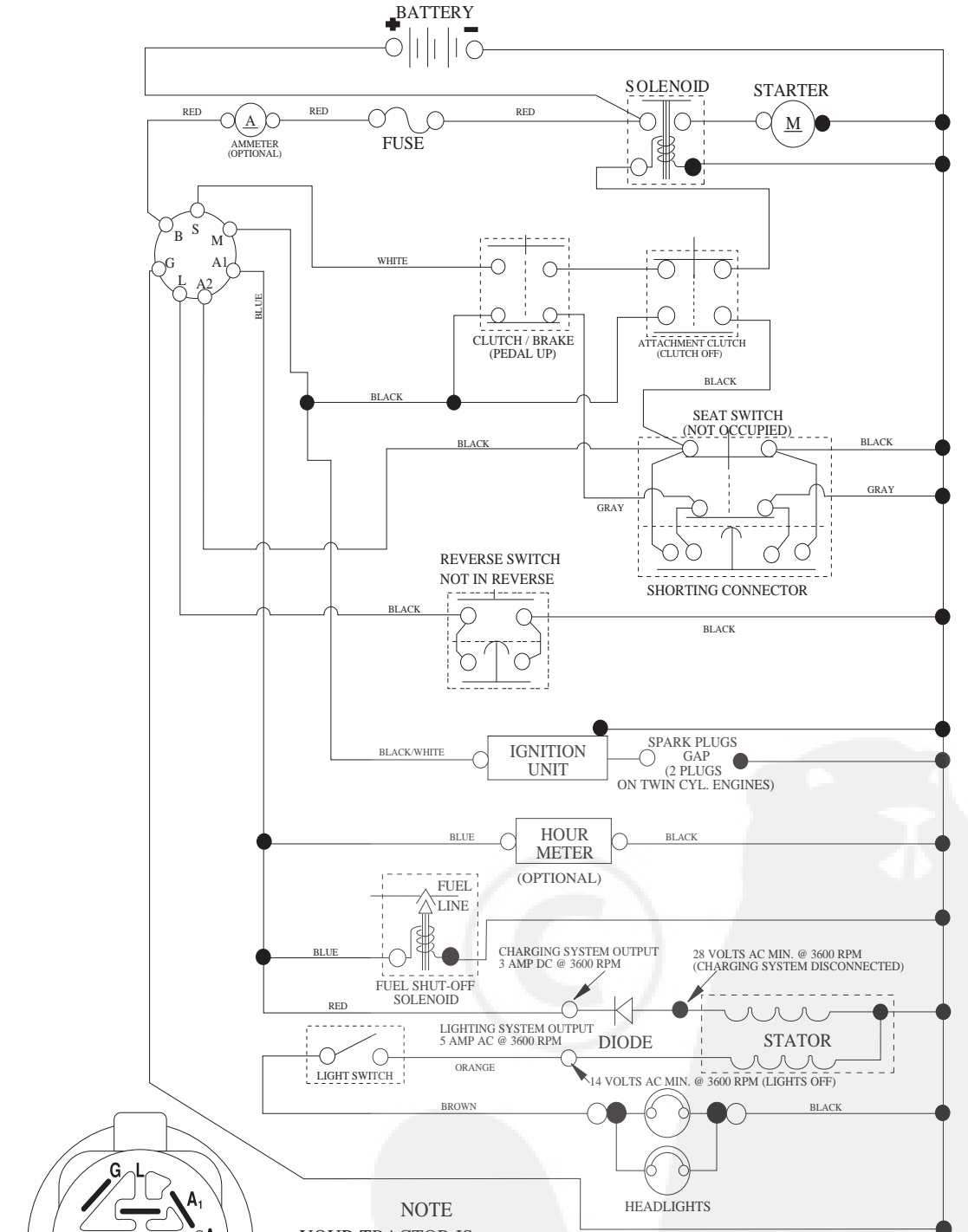

IGNITION SWITCH

POSITION	CIRCUIT	"MAKE"
OFF	M+G+A1	
RUN/OVERRIDE	B+A1	
RUN	B+A1	L+A2
START	B + S + A1	

NOTE

YOUR TRACTOR IS EQUIPPED WITH A SPECIAL ALTERNATOR SYSTEM. THE LIGHTS ARE NOT CONNECTED TO THE BATTERY, BUT HAVE THEIR OWN ELECTRICAL SOURCE. BECAUSE OF THIS, THE BRIGHTNESS OF THE LIGHTS WILL CHANGE WITH ENGINE SPEED. AT IDLE THE LIGHTS WILL DIM. AS THE ENGINE IS SPEEDED UP, THE LIGHTS WILL BECOME THEIR BRIGHTEST.

● NON-REMOVABLE CONNECTIONS

○ REMOVABLE CONNECTIONS

WIRING INSULATED CLIPS
NOTE: IF WIRING INSULATED CLIPS WERE REMOVED FOR SERVICING OF UNIT, THEY SHOULD BE RE-INSTALLED TO PROPERLY SECURE YOUR WIRING.

TRACTOR-MODEL NO. LZ145H107AK(96011017703), PRODUCT NO. 960 11 01-77
ELECTRICAL

L02

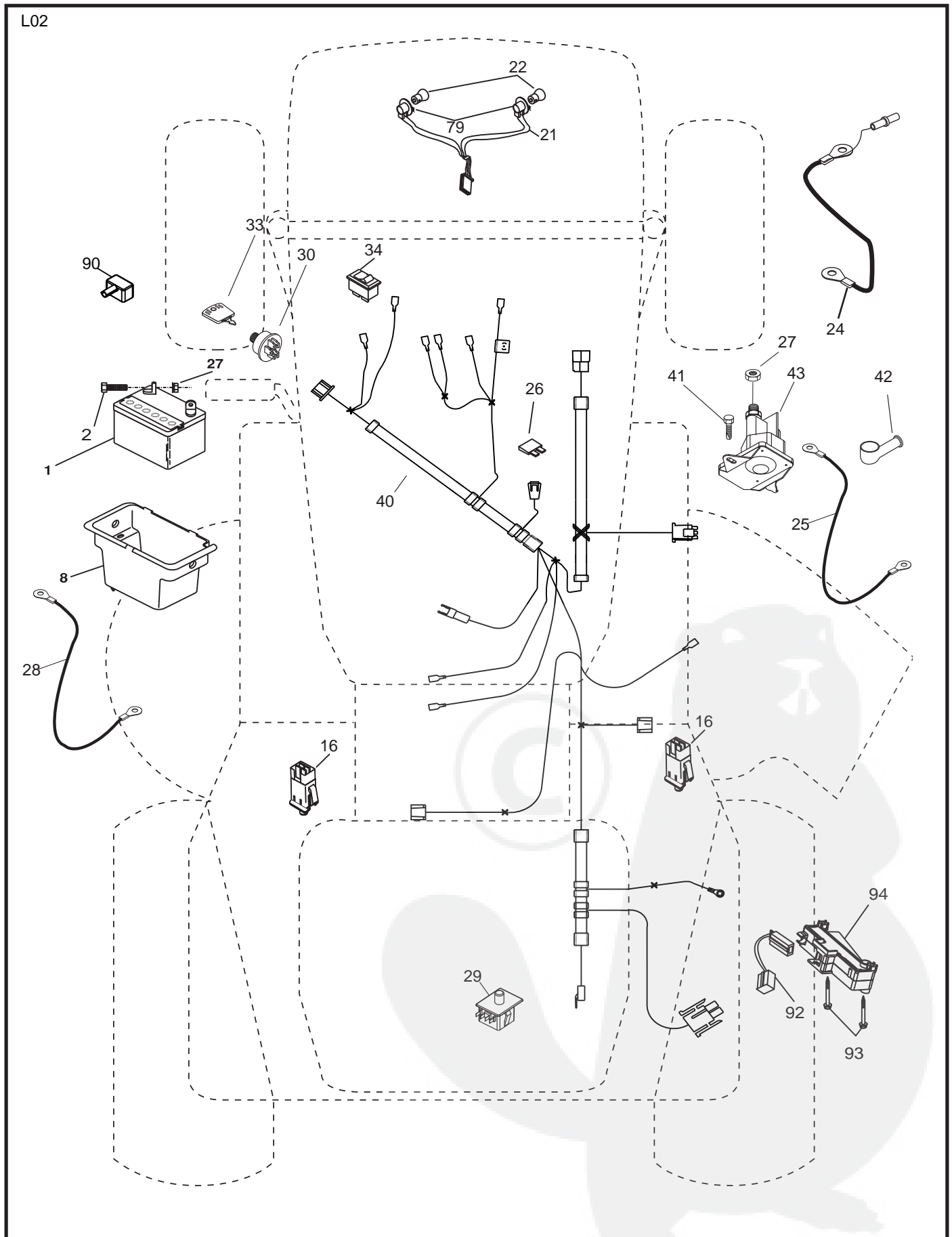

**TRACTOR-MODEL NO. LZ145H107AK(96011017703), PRODUCT NO. 960 11 01-77
ELECTRICAL**

KEY NO.	PART NO.	DESCRIPTION
1	532 16 34-65	Battery
2	874 76 04-12	Bolt Hex Hd 1/4-20 unc x 3/4
8	532 17 66-89	Battery Box
16	532 17 61-38	Switch Interlock Push-In
21	532 18 37-59	Harness Asm Light w/4152j
22	532 00 41-52	Bulb Light #1156
24	532 42 12-99	Cable Battery 6 Ga. 11" red
25	532 42 12-97	Cable Battery 6 Ga. 44" red w/16 wire
26	532 17 51-58	Fuse 20 AMP
27	873 51 04-00	Nut Keps Hex 1/4-20 unc
28	532 42 12-98	Cable Ground 6 Ga. 12" black
29	532 19 27-49	Switch Seat
30	532 19 33-50	Switch Ignition
33	532 41 19-35	Key/Chain
34	532 11 07-12	Switch Light/Reset B/B/Red
40	532 19 74-28	Harness Ignition
41	871 11 04-08	Bolt Blk Fin Hex 1/4 - 20 x 1/2
42	532 13 15-63	Cover Terminal Red
43	532 19 25-07	Solenoid
79	532 17 52-42	Socket Asm. Bulb
90	532 18 04-49	Cover Terminal Battery
92	532 19 66-15	Harness Pigtail Console ROS
93	532 19 25-40	Screw Plastite 10-14 x 2.0
94	532 19 18-34	Module Reverse ROS

NOTE: All component dimensions given in U.S. inches.
1 inch = 25.4 mm.

TRACTOR-MODEL NO. LZ145H107AK(96011017703), PRODUCT NO. 960 11 01-77
CHASSIS AND ENCLOSURES

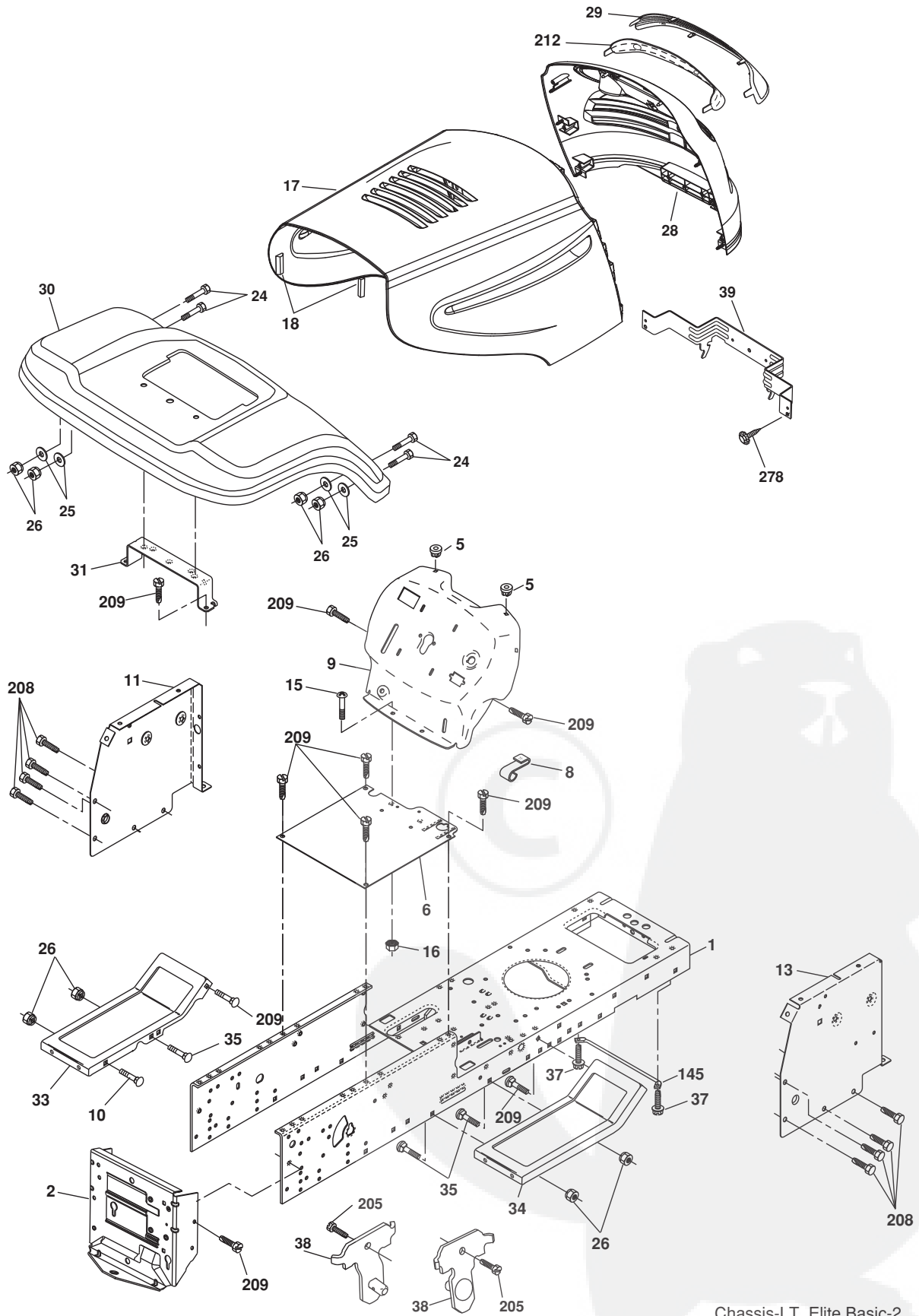

Chassis-LT_Elite Basic-2

**TRACTOR-MODEL NO. LZ145H107AK(96011017703), PRODUCT NO. 960 11 01-77
CHASSIS AND ENCLOSURES**

KEY NO.	PART NO.	DESCRIPTION
1	532 17 46-20	Chassis Stamping
2	532 17 65-54	Drawbar
5	532 15 52-72	Bumper Hood/Dash
6	532 18 44-19	Saddle
8	532 15 51-38	Clip Retainer
9	532 19 46-88	Dash
10	872 14 06-08	Bolt Carriage 3/8-16 x 1
11	532 17 49-96	Dashboard, Panel LH
13	532 18 69-52	Dashboard, Panel RH
15	874 18 05-12	Screw Mach Thdr 5/16-18 unc x 3/4
16	873 51 05-00	Nut Keps 5/16-18 unc
17	532 18 67-07	Hood Pnt
18	532 18 49-21	Bumper Hood
24	874 78 06-16	Bolt Fin Hex 3/8-16 unc x 1 Gr. 5
25	819 13 13-12	Washer 13/32 x 13/16 x 12 Ga.
26	873 80 06-00	Nut Lock Hex w/Ins 3/8-16 unc
28	532 18 38-26	Grille Asm. (Includes key nos. 29 & 212)
29	532 18 98-37	Lens Grille
30	532 19 58-55	Fender
31	532 13 66-19	Bracket Fender
33	532 18 11-93	Footrest LH
34	532 18 11-94	Footrest RH
35	872 11 06-06	Bolt Rdhd Sqnk 3/8-16 x 3/4
37	817 49 05-08	Screw Thdrol 5/16-18 x 1/2 TYT
38	532 17 57-10	Bracket Asm Pivot Mower Rear
39	532 40 78-07	Bracket Pivot
145	532 40 91-67	Rod Pivot Chassis/Hood
205	817 49 06-08	Screw Thdrol 3/8-16 x 1/2
208	817 67 06-08	Screw Thdrol 3/8-16 x 1/2 TYT Bl
209	817 00 06-12	Screw Hexwsh Thdr 3/8-16 x 3/4
212	532 18 38-23	Insert Lens Reflect
278	532 41 63-58	Screw #10 x 0.750
--	532 00 54-79	Plug Button

NOTE: All component dimensions given in U.S. inches
1 inch = 25.4 mm

TRACTOR-MODEL NO. LZ145H107AK(96011017703), PRODUCT NO. 960 11 01-77
DRIVE

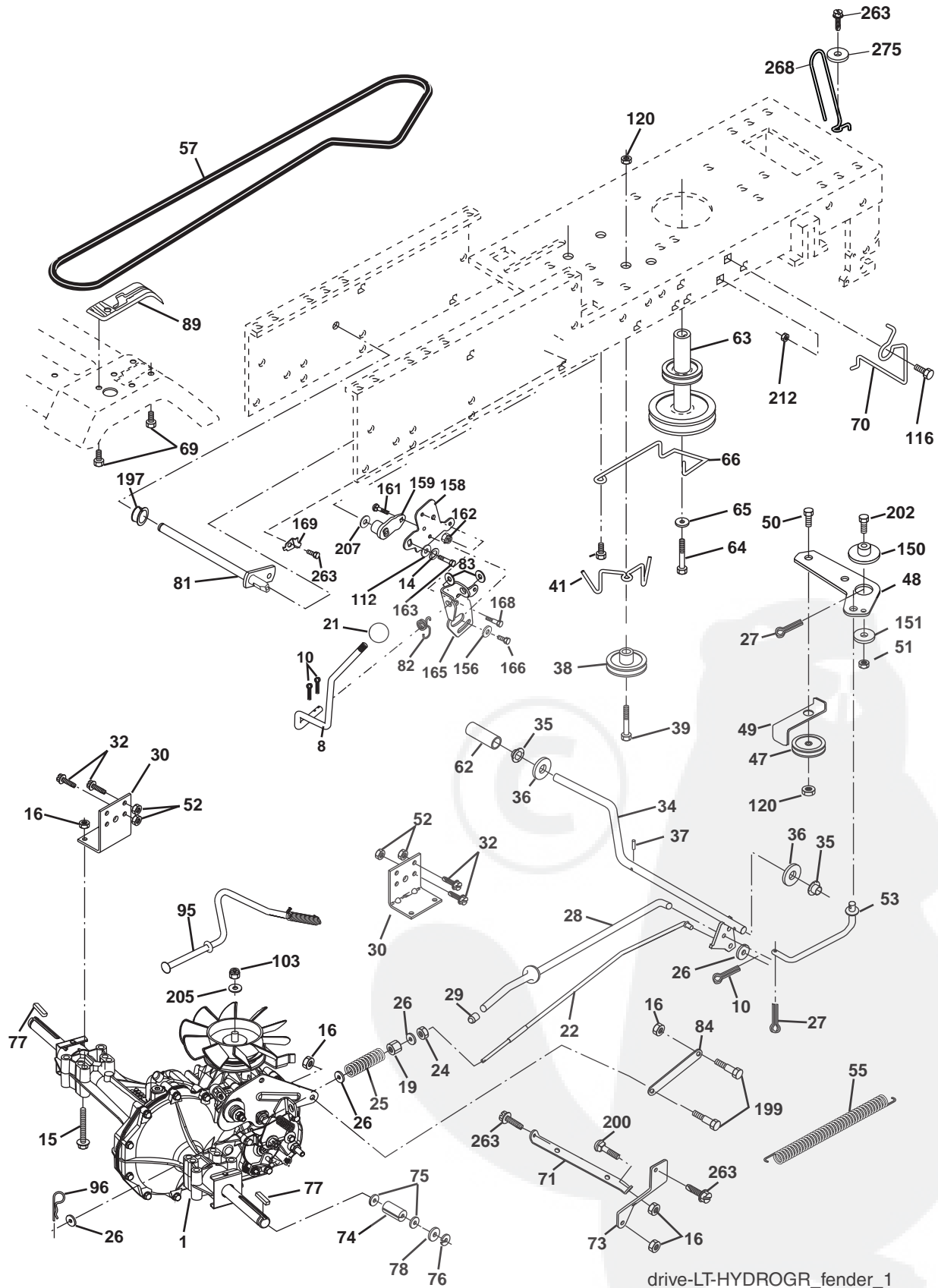

drive-LT-HYDROGR_fender_1

**TRACTOR-MODEL NO. LZ145H107AK(96011017703), PRODUCT NO. 960 11 01-77
DRIVE**

KEY NO.	PART NO.	DESCRIPTION	KEY NO.	PART NO.	DESCRIPTION
1	-----	Transaxle Hydro Gr 322-0510 (Order parts from transaxle manufacturer)	73	532 16 91-82	Strap Torque Rh Hydro
8	532 19 27-06	Rod Shift Fender	74	532 13 70-57	Spacer, Axle
10	876 02 04-16	Pin Cotter 1/8 x 1 CAD	75	532 12 17-49	Washer 25/32 x 1-1/4 x 16 Ga.
14	810 04 04-00	Washer Lock Hvy Helical 1/4	76	812 00 00-01	E-Ring
15	874 49 05-44	Bolt Hex Flg Hd 5/16-18 x Gr. 5	77	532 12 35-83	Key, Square
16	873 80 05-00	Nut Lock Hex w/Ins. 5/16-18 unc	78	532 12 17-48	Washer 25/32 x 1-5/8 x 16 Ga.
19	873 80 06-00	Nut Lock Hex w/Wsh 3/8-16 unc	81	532 16 55-96	Shaft Asm. Cross Hydro
21	532 10 69-33	Knob	82	532 16 57-11	Spring Torsion T/A
22	532 16 94-98	Rod, Brake Hydro	83	819 17 12-16	Washer 17/32 x 3/4 x 16 Ga.
24	873 35 06-00	Nut	84	532 16 98-43	Link Transaxle
25	532 10 68-88	Spring, Brake Rod	89	532 19 49-72	Console, Shift
26	819 13 13-16	Washer	95	532 17 02-01	Control Asm Bypass Hydro
27	876 02 04-12	Pin Cotter 1/8 x 3/4 CAD.	96	532 12 47-88	Retainer Spring 1" Zinc/Cad
28	532 17 57-65	Rod, Parking Brake	103	873 94 08-00	Nut Hex Jam Toplock 1/2-20 unf
29	532 07 16-73	Cap, Parking Brake	112	819 09 12-10	Washer 9/32 x 3/4 x 10 Ga.
30	532 17 49-73	Bracket, Transaxle	116	872 14 06-08	Bolt 3/8-16 unc x 1
32	874 76 05-12	Bolt Hex Hd 5/16-18 unc x 3/4	120	873 90 06-00	Nut Lock 3/8-16 unc
34	532 17 55-78	Shaft, Foot Pedal	150	532 17 54-56	Spacer Retainer
35	532 12 01-83	Bearing, Nylon	151	819 13 32-10	Washer 13/32 x 2 x 10 Ga.
36	819 21 16-16	Washer	156	532 16 60-02	Washer Srrtd 5/16 ID x 1.0 x .125 Tk
37	532 12 49-63	Pin, Roll	158	532 16 55-89	Bracket Shift Mount
38	532 17 91-14	Pulley, Idler, Composite	159	532 18 39-00	Hub Shift
39	872 11 06-22	Bolt Fin Hex 3/8-16 unc x 2-3/4	161	872 14 04-06	Bolt Rdhd Sqnk 1/4-20 x 3/4 Gr. 5
41	532 17 55-56	Keeper, Belt Idler	162	873 68 04-00	Nut Crownlock 1/4-20 unc
47	532 12 77-83	Pulley, Idler, V-Groove	163	874 78 04-16	Bolt Hex Fin 1/4-20 unc x 1 Gr. 5
48	532 15 44-07	Bellcrank Clutch Grnd Drv Stl	165	532 16 56-23	Bracket Pivot Lever
49	532 12 32-05	Retainer, Belt	166	817 49 05-10	Screw 5/16-18 x 5/8 TT Yellow
50	872 11 06-12	Bolt 3/8-16 unc x 1-1/2	168	532 16 54-92	Bolt Shoulder 5/16-18 x .561 TT
51	873 68 06-00	Nut Crownlock 3/8-16	169	532 16 55-81	Plate Fastening
52	873 68 05-00	Nut Crownlock 5/16-18	197	532 16 96-13	Nyliner Snap-In 5/8" ID
53	532 19 96-52	Link, Clutch	199	532 16 96-12	Bolt Shoulder 5/16-18 unc
55	532 10 57-09	Spring, Return, Clutch	200	872 14 05-08	Bolt Rdhd Sqnk 5/16-18 unc x 1
56	817 06 06-20	Bolt Fin Hex 3/8-16 unc x 1-1/4	202	872 11 06-14	Bolt Carr Sh 3/8-16 x 1-3/4 Gr. 5
57	532 14 02-94	V-Belt, Ground Drive	205	819 17 16-16	Washer 17/32 x 1 x 16 Ga.
62	532 12 48-72	Cover, Pedal	207	532 16 98-45	Washer Nyl
63	532 18 02-19	Pulley, Eng	212	532 14 52-12	Nut Hexflange Lock
64	532 17 39-37	Bolt Hex 7/16-20 x 4 Gr. 5-1.5	263	817 00 06-12	Screw 3/8-16 x 3/4
65	810 04 07-00	Washer	268	532 18 24-02	Guard Muffler
66	532 15 47-78	Keeper Belt Engine	275	819 13 16-14	Washer 13/32 x 1 x 14 Ga.
69	532 14 24-32	Screw Hex Wsh 1/4-1/2 unc			
70	532 18 02-18	Guide Belt Mower Drive RH			
71	532 16 91-83	Strap Torque Lh Hydro			

NOTE: All component dimensions given in U.S. inches
1 inch = 25.4 mm

TRACTOR-MODEL NO. LZ145H107AK(96011017703), PRODUCT NO. 960 11 01-77
STEERING ASSEMBLY

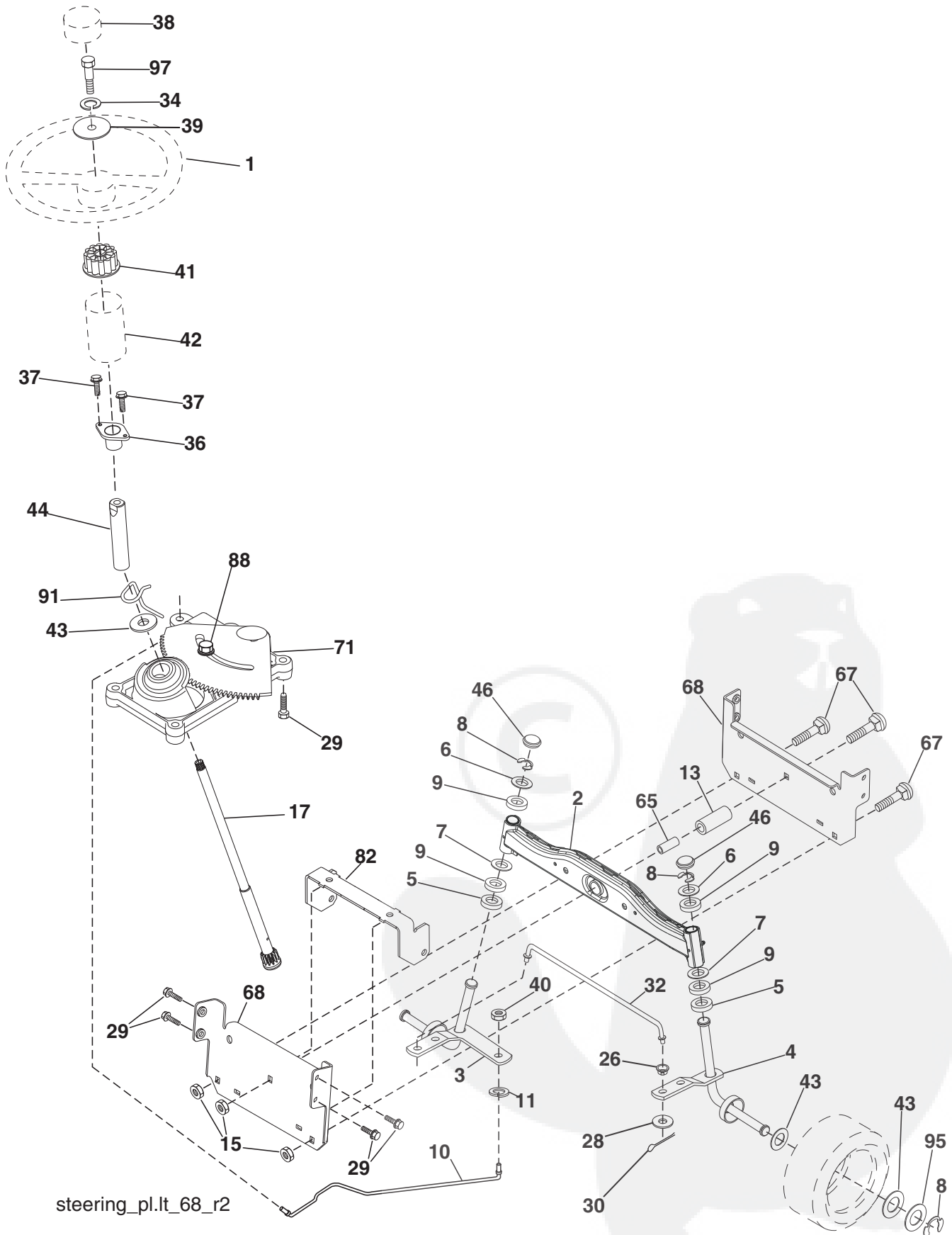

steering_pl.lt_68_r2

**TRACTOR-MODEL NO. LZ145H107AK(96011017703), PRODUCT NO. 960 11 01-77
STEERING ASSEMBLY**

KEY NO.	PART NO.	DESCRIPTION
1	532 19 45-95	Wheel Steering
2	532 41 81-68	Axle Asm
3	532 16 98-40	Spindle Asm LH
4	532 16 98-39	Spindle Asm RH
5	532 12 49-31	Bearing Race Thrust Harden
6	532 12 17-48	Washer 25/32 x 1-5/8 x 16 Ga.
7	819 27 20-16	Washer 27/32 x 1-1/4 x 16 Ga.
8	812 00 00-29	Ring Klip #t5304-75
9	532 12 49-37	Bearing Col Strg Blk
10	532 17 51-21	Link Drag
11	810 04 06-00	Washer Lock Hvy Hlcl Spr 3/8
13	532 13 65-18	Spacer Brg Axle Front
15	532 14 52-12	Nut Hex Flange Lock
17	532 19 07-53	Shaft Asm Strg
26	532 12 68-47	Bushing Link Drag Blk LR
28	819 13 14-16	Washer 13/32 x 7/8 x 16 Ga.
29	817 00 06-12	Screw 3/8-16 x 3/4
30	876 02 04-12	Pin Cotter 1/8 x 3/4 Cad
32	532 19 27-57	Rod Tie Wire Form 19 75 Mech
34	810 04 05-00	Washer Lock Hvy Hlcl Spr 5/16
36	532 15 50-99	Bushing Strg
37	532 15 29-27	Screw
38	532 19 46-03	Cap Strg Wh
39	819 11 38-12	Washer 11/32 ID- 2-3/8 OD x 12 Ga.
40	873 54 06-00	Lock nut
41	532 18 67-37	Adaptor Wheel Strg
42	532 16 96-33	Boot Steering Shaft
43	532 12 17-49	Washer 25/32 x 1-1/4 x 16 Ga.
44	532 19 07-52	Extension Steering Shaft LR/LT
46	532 12 12-32	Cap Spindle Fr Top Blk
65	532 41 47-36	Spacer Brace Axle
67	872 11 06-18	Bolt, Rdhd Sqnk 3/8-16 x 2-1/4
68	532 16 98-27	Axle, Brace
71	532 17 51-46	Steering Asm.
82	532 19 99-78	Bracket Susp Chassis Front
88	532 17 51-18	Bolt Shoulder 7/16-20
91	532 17 55-53	Clip Steering
95	532 18 89-67	Washer Hardened
97	874 78 05-64	Bolt 5/16-18 unc x 4"L Gr. 5

NOTE: All component dimensions given in U.S. inches.
1 inch = 25.4 mm.

**TRACTOR-MODEL NO. LZ145H107AK(96011017703), PRODUCT NO. 960 11 01-77
ENGINE**

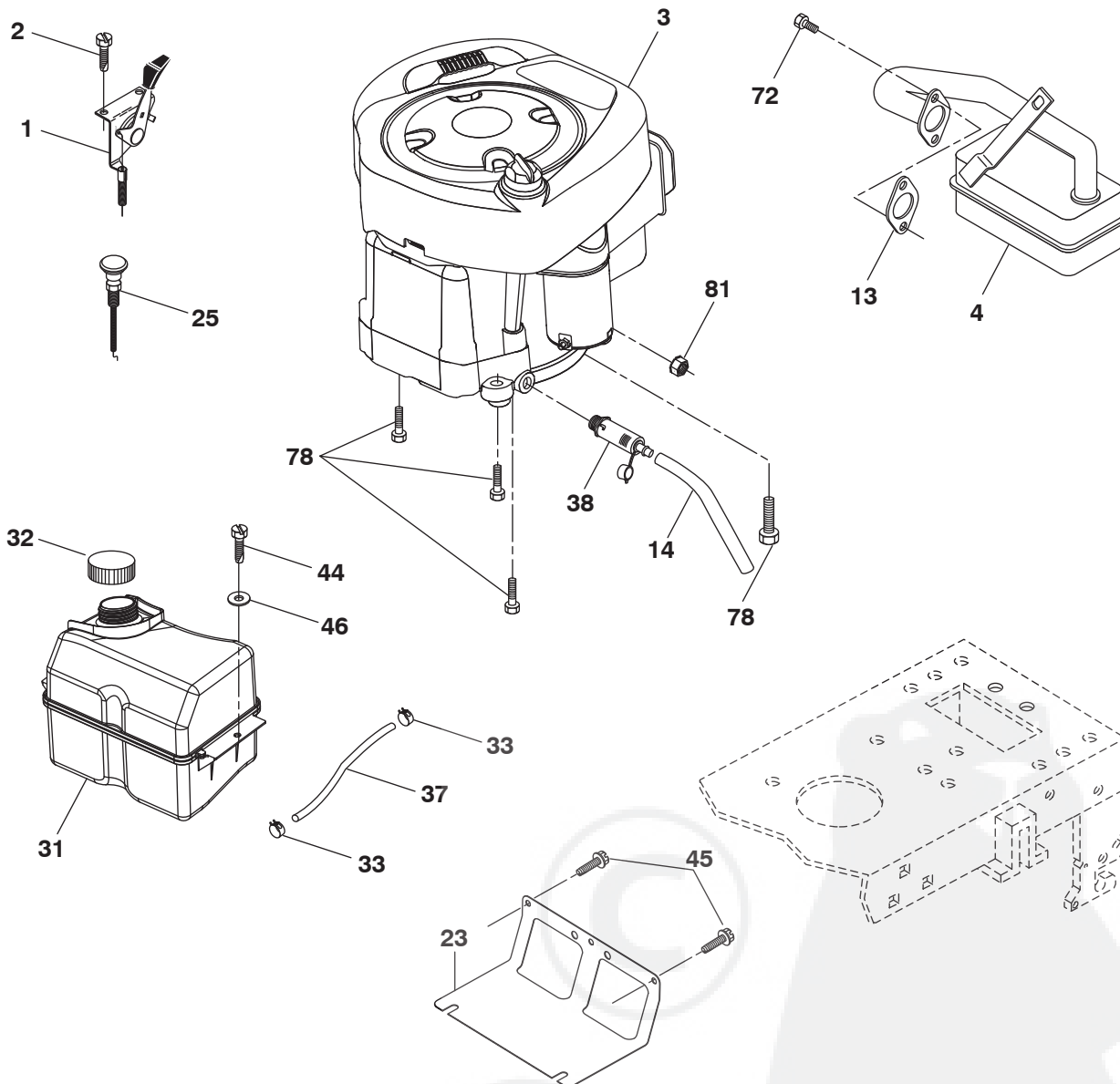

29

OPTIONAL EQUIPMENT
Spark Arrester

engine-bs.1cyl_59

TRACTOR-MODEL NO. LZ145H107AK(96011017703), PRODUCT NO. 960 11 01-77 ENGINE

KEY NO.	PART NO.	DESCRIPTION
1	532 17 05-51	Control Throttle/Choke
2	817 72 04-08	Screw Hex Thd Cut 1/4-20 x 1/2
3	-----	Engine B&S Model No. 31A507
4	532 13 73-52	Muffler
13	532 16 52-91	Gasket Eng 1 313 Id Tin Plated
14	532 14 84-56	Tube Drain Oil Easy
23	532 16 98-37	Shield Brn/Dbr Guard
25	532 19 06-95	Control Choke
29	532 13 71-80	Kit Spark Arrestor (Flat Scrn)
31	532 40 75-51	Tank Fuel
32	532 19 77-25	Cap Asm Fuel
33	532 12 34-87	Clamp Hose Black
37	532 13 70-40	Line Fuel 20"
38	532 18 16-54	Plug Drain Oil Easy
44	817 67 04-12	Screw Hexwsh Thdrol 1/4-20 x 3/4
45	817 00 06-12	Screw Hex Wsh Thdrol 3/8-16 x 3/4
46	819 09 14-16	Washer 9/32 x 7/8 x 16 Ga.
72	532 19 23-34	Screw Socket Hd 5/16-18 x .75
78	817 06 06-20	Screw 3/8-16 x 1-1/4
81	873 51 04-00	Nut 1/4-20

NOTE: All component dimensions given in U.S. inches
1 inch = 25.4 mm

Engine Power Rating Information

The gross power rating for individual gas engine models is labeled in accordance with SAE (Society of Automotive Engineers) code J11940 (Small Engine Power & Torque Rating Procedure), and rating performance has been obtained and corrected in accordance with SAE J1995 (Revision 2002-5). Actual gross engine power will be lower and is affected by, among other things, ambient operating conditions and engine-to-engine variability. Given both the wide array of products on which engines are placed and the variety of environmental issues applicable to operating the equipment, the gas engine will not develop the rated gross power when used in a given piece of power equipment (actual "on-site" or net horsepower). This difference is due to a variety of factors including, but not limited to, accessories (air cleaner, exhaust, charging, cooling, carburetor, fuel pump, etc.), application limitations, ambient operating conditions (temperature, humidity, altitude), and engine-to-engine variability. Due to manufacturing and capacity limitations, Briggs & Stratton may substitute an engine of higher rated power for this Series engine.

**TRACTOR-MODEL NO. LZ145H107AK(96011017703), PRODUCT NO. 960 11 01-77
SEAT ASSEMBLY**

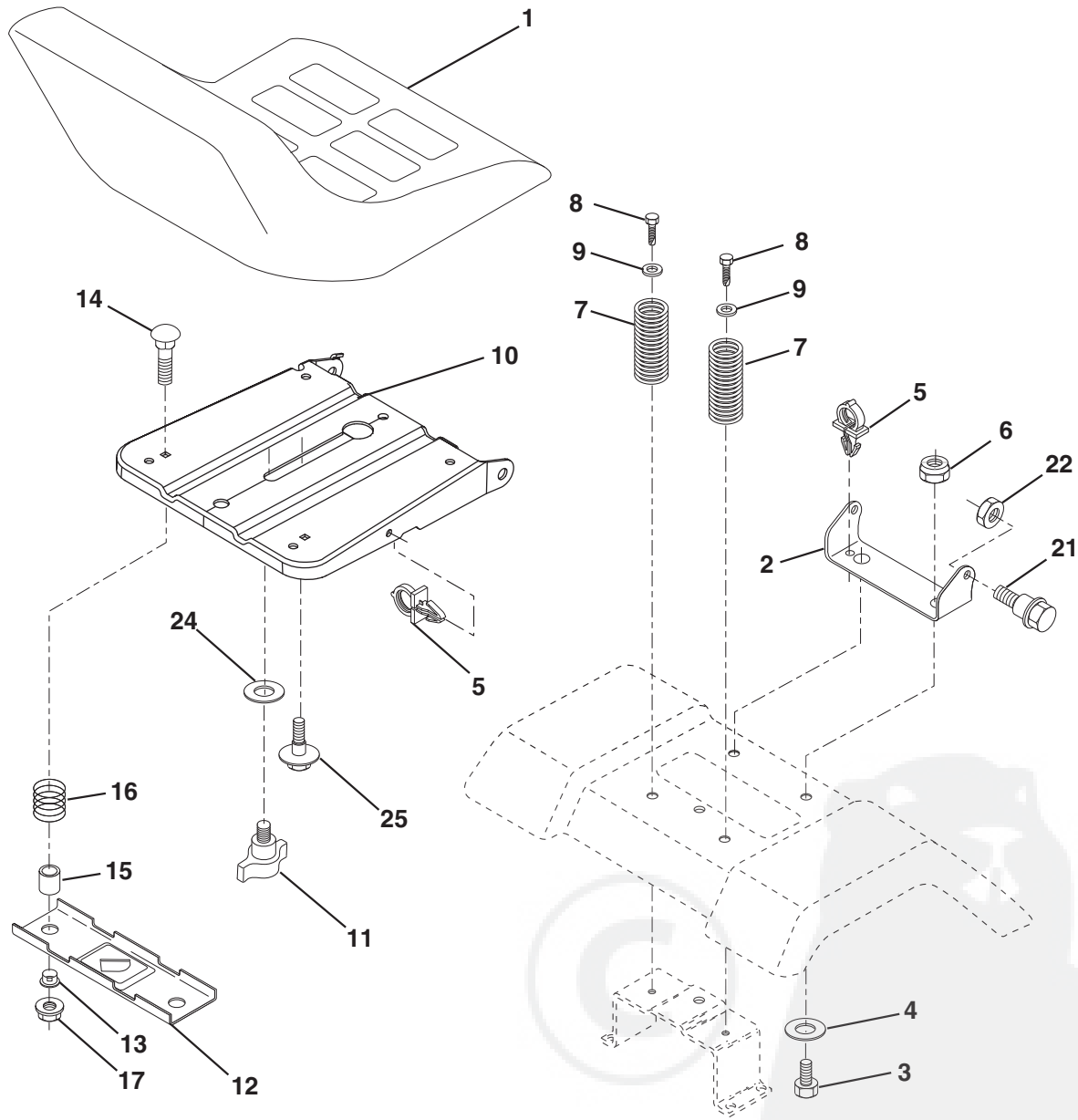

seat_lt.knob_13

KEY NO.	PART NO.	DESCRIPTION
1	532 18 87-13	Seat
2	532 14 05-51	Bracket Pivot Fender
3	871 11 06-16	Bolt Fin Hex 3/8-16 unc x 1
4	819 13 16-10	Washer 13/32 x 1 x 10 Ga.
5	532 14 50-06	Clip Push-In
6	873 80 06-00	Nut Hex w/Ins. 3/8-16 unc
7	532 12 41-81	Spring Seat Cprsn 2 250 Blk Zi
8	817 00 06-16	Screw 3/8-16 x 1-1/2
9	819 13 16-14	Washer 13/32 x 1 x 14 Ga.
10	532 19 55-30	Pan Seat
11	532 16 63-69	Knob Seat
12	532 17 46-48	Bracket Mounting Switch

KEY NO.	PART NO.	DESCRIPTION
13	532 12 12-48	Bushing Snap Blk Nyl 50 Id
14	872 05 04-12	Bolt Rdhd Sqnk 1/4-20 x 1-1/2
15	532 13 43-00	Spacer Split 28x 96 Yel Zinc
16	532 12 12-50	Spring Cprsn 1 27 Blk Pnt
17	532 12 39-76	Nut Lock 1/4 Lge Flg Gr. 5 Zinc
21	532 17 18-52	Bolt Shoulder 5/16-18 unc
22	873 80 05-00	Nut Hex Lock w/Ins 5/16-18
24	819 17 19-12	Washer 17/32 x 1-3/16 x 12 Ga.
25	532 12 70-18	Bolt Shoulder 5/16-18 x 62

NOTE: All component dimensions given in U.S. inches.
1 inch = 25.4 mm

**TRACTOR-MODEL NO. LZ145H107AK(96011017703), PRODUCT NO. 960 11 01-77
DECALS**

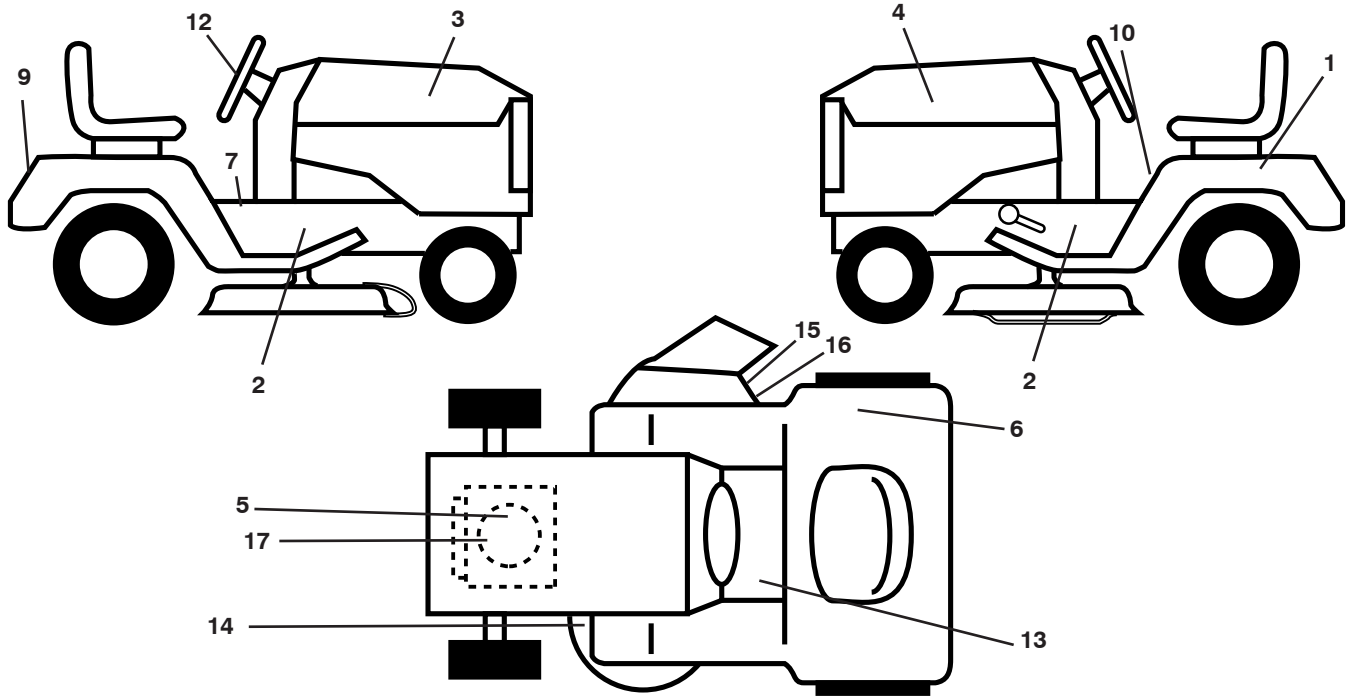

KEY NO.	PART NO.	DESCRIPTION
1	532 14 50-05	Decal, Battery Danger
2	532 15 97-36	Decal, Chassis
3	532 19 69-29	Decal, Hood RH
4	532 19 69-30	Decal, Hood LH
5	532 19 68-41	Decal, Warning Engine
6	532 18 04-32	Decal, Fender 100 DB/CE
7	532 14 08-37	Decal, Saddle Brake
9	532 19 56-99	Decal, Fender
10	532 40 03-89	Decal, Warning Syms. CE
12	532 40 20-35	Decal, Whl Strg.
13	532 15 97-37	Decal, Brake/Clutch Symbol LT
14	532 16 03-96	Decal, V-Belt Schematic

KEY NO.	PART NO.	DESCRIPTION
15	532 18 21-66	Decal, Mower Cutting Finger Symbol
16	532 19 63-57	Decal, Deck Warn.
17	532 41 67-25	Decal, Engine HP
--	532 16 25-98	Decal, Drawbar Load Limit
--	532 16 69-60	Decal, By-Pass
--	532 13 83-11	Decal, Handle Lft Height Adjust
--	532 18 10-90	Pad Footrest RH
--	532 18 10-91	Pad Footrest LH
--	532 40 08-95	Manual Operator's (Euro.)
--	532 40 08-96	Manual Operator's (Scand.)
--	532 45 21-87	Manual Parts

WHEELS & TIRES

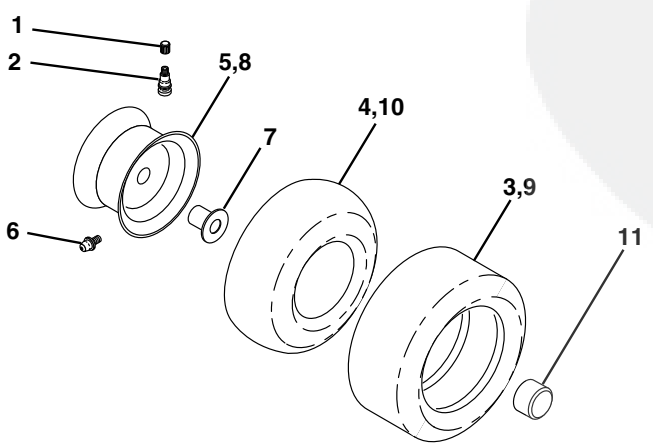

KEY NO.	PART NO.	DESCRIPTION
1	532 05 91-92	Cap Valve Tire
2	532 06 51-39	Stem Valve
3	532 10 62-22	Tire F Ts 15 x 6 0 - 6
4	532 05 99-04	Tube Front (Service Item Only)
5	532 18 33-37	Rim Asm 6" Front
6	532 12 49-57	Fitting Grease (Front Wheel Only)
7	532 12 49-59	Bearing Flange (Front Wheel Only)
8	532 18 33-38	Rim Asm 8" Rear Service
9	532 42 05-31	Tire Rear 18 x 9.5-8 "Turf Saver LT"
10	532 12 49-26	Tube Rear (Service Item Only)
11	532 17 50-39	Cap Axle Blk 1 50 x 1 00
--	532 14 43-34	Sealant, Tire (10 oz. Tube)

NOTE: All component dimensions given in U.S. inches
1 inch = 25.4 mm

TRACTOR-MODEL NO. LZ145H107AK(96011017703), PRODUCT NO. 960 11 01-77
MOWER DECK

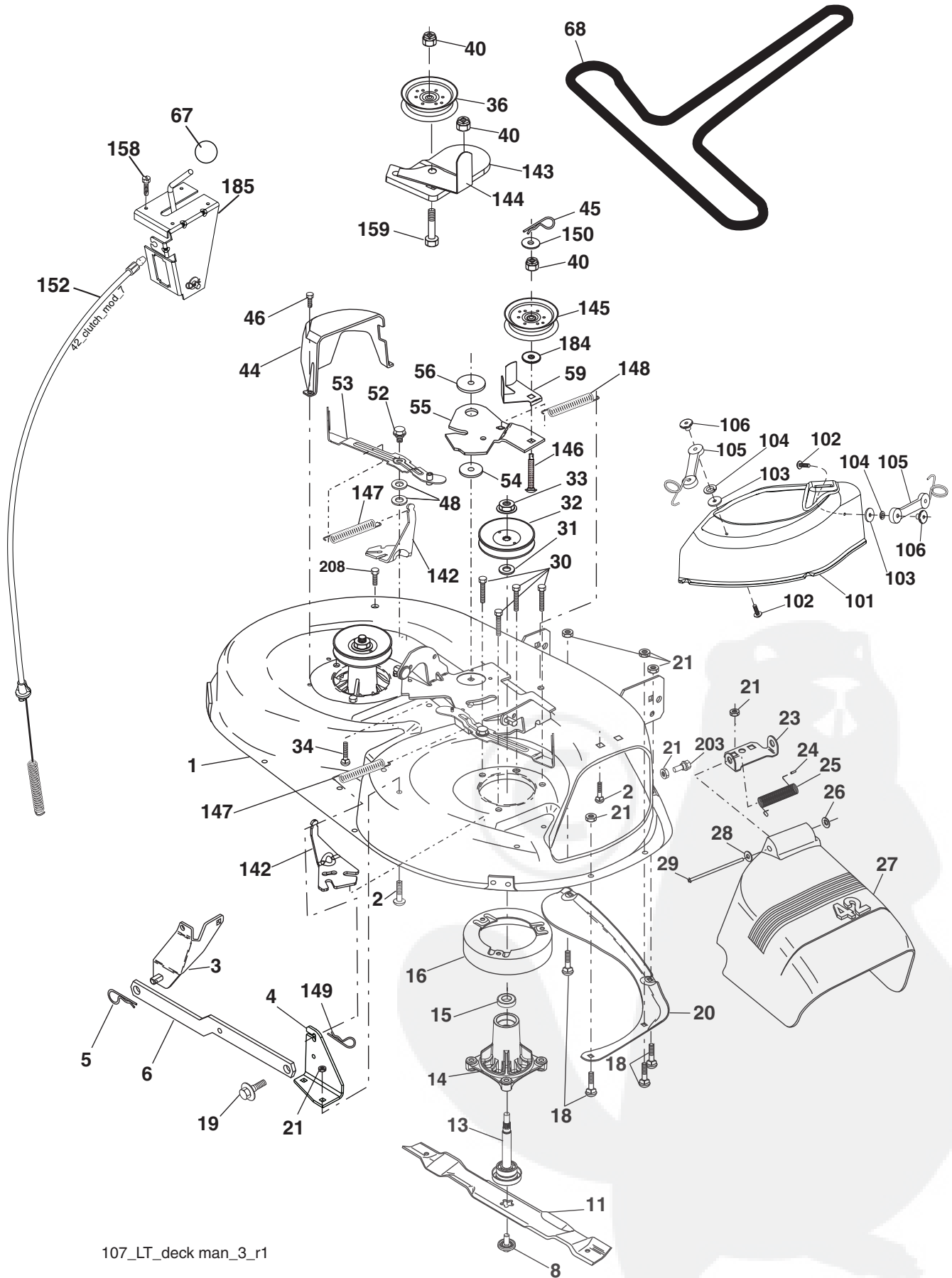

107_LT_deck man_3_r1

**TRACTOR-MODEL NO. LZ145H107AK(96011017703), PRODUCT NO. 960 11 01-77
MOWER DECK**

KEY NO.	PART NO.	DESCRIPTION	KEY NO.	PART NO.	DESCRIPTION
1	532 16 58-92	Deck Asm MWR 42"weldment	56	532 16 57-23	Spacer Retainer Mower
2	872 14 05-06	Bolt Rdhd Sqnk 5/16-18 unc x 3/4	59	532 14 10-43	Guard TUV Idler
3	532 13 80-17	Bracket Asm Fr Sway Bar 38/42	67	532 10 69-32	Knob Rd 3/8-16 Plstc Thds Blk
4	532 16 54-60	Bracket Asm Deck 42"sway Bar	68	532 18 02-15	V-Belt Mower 42"
5	532 12 46-70	Retainer Spring	101	532 19 31-07	Cover Mulching
6	532 17 80-24	Bar Sway Deck	102	871 08 10-10	Screw 10-24 x 5/8
8	532 19 30-03	Bolt/Washer Asm 7/16-20 UNF	103	819 06 12-16	Washer
11	532 13 41-49	Blade Mulching	104	810 07 10-00	Washer Lock
13	532 19 28-72	Shaft Asm Mandrel	105	532 16 07-93	Latch Asm
14	532 18 72-81	Housing Mandrel	106	532 12 50-04	Nut Weld
15	532 11 04-85	Bearing Ball Mandrel	142	532 19 57-84	Arm Spring Brake Mower
16	532 17 44-93	Stripper Mower Vented	143	532 15 71-09	Bracket Arm Idler 42"
18	872 14 05-05	Bolt Rdhd Sqnk 5/16-18 x 5/8	144	532 15 86-34	Keeper Belt 42" Clutch Idler
19	532 13 28-27	Bolt Shoulder	145	532 16 58-88	Pulley Idler Flat
20	532 15 97-70	Baffle Vortex 42	146	532 17 19-77	Bolt Carriage Idler
21	873 68 05-00	Nut Crownlock 5/16-18 unc	147	532 17 97-48	Spring Extension
23	532 17 75-63	Bracket Deflector Mower 42"	148	532 16 90-22	Spring Return Idler
24	532 10 53-04	Cap Sleeve 80x 112 Blk Mower	149	532 16 58-98	Retainer Spring Yellow
25	532 12 37-13	Spring Torsion Deflector 2 52	150	819 09 12-10	Washer 9/32 x 3/4 x 10 Ga.
26	532 11 04-52	Nut Push Phos & Oil	152	532 18 15-55	Clutch Cable 42"
27	532 17 18-59	Shield Deflector Mower	158	817 72 04-08	Screw Hex Thd Cut 1/4-20 x 1/2
28	819 11 10-16	Washer 11/32 x 5/8 x 16 Ga.	159	872 14 06-14	Bolt Rdhd Sqn 3/8-16 unc x 1-3/4
29	532 13 14-91	Rod Hinge 42"6 75 Wlg	184	819 13 14-10	Washer 13/32 x 7/8 x 10 Ga.
30	532 17 39-84	Screw Thd Rolling Washer Head	185	532 18 82-34	Head Asm. Cable Clutch
31	532 18 76-90	Washer Spacer	203	872 11 05-05	Bolt Carr. 5/16 - 18 x 5/8
32	532 15 35-35	Pulley Mandrel 42"	208	817 67 06-08	Screw THDROL 3/8-16 x 1/2
33	532 40 02-34	Nut Flange Lock Top	--	532 19 28-70	Mandrel Assembly (Includes hous- ing, shaft assembly, and bearing only - pulley/nut/washer and blade bolt/washers not included)
34	872 11 06-12	Bolt Rdhd 3/8-16 unc x 1-1/2 Gr. 5			
36	532 13 14-94	Pulley Idler Flat 3 060			
40	873 90 06-00	Nut Lock Flg 3/8-16 unc			
44	532 14 00-88	Guard Mandrel LH Black	--	532 41 66-11	Replacement Mower, Complete (Std. Deck-Order separately gauge wheel components key nos. 116-119)
45	532 12 47-88	Spring Retainer 1" Zinc/cad			
46	532 13 77-29	Screw Hex Thd Cut 1/4-20 x 5/8 T			
48	532 13 39-44	Washer Hardened Smaller			
52	532 13 98-88	Bolt Shoulder 5/16-18 unc Blkz			
53	532 18 49-07	Arm Asm Pad Brake			
54	532 17 85-15	Washer Hardened			
55	532 15 50-46	Arm Idler 42"mower LT/YT			

NOTE: All component dimensions given in U.S. inches
1 inch = 25.4 mm

TRACTOR-MODEL NO. LZ145H107AK(96011017703), PRODUCT NO. 960 11 01-77
MOWER LIFT

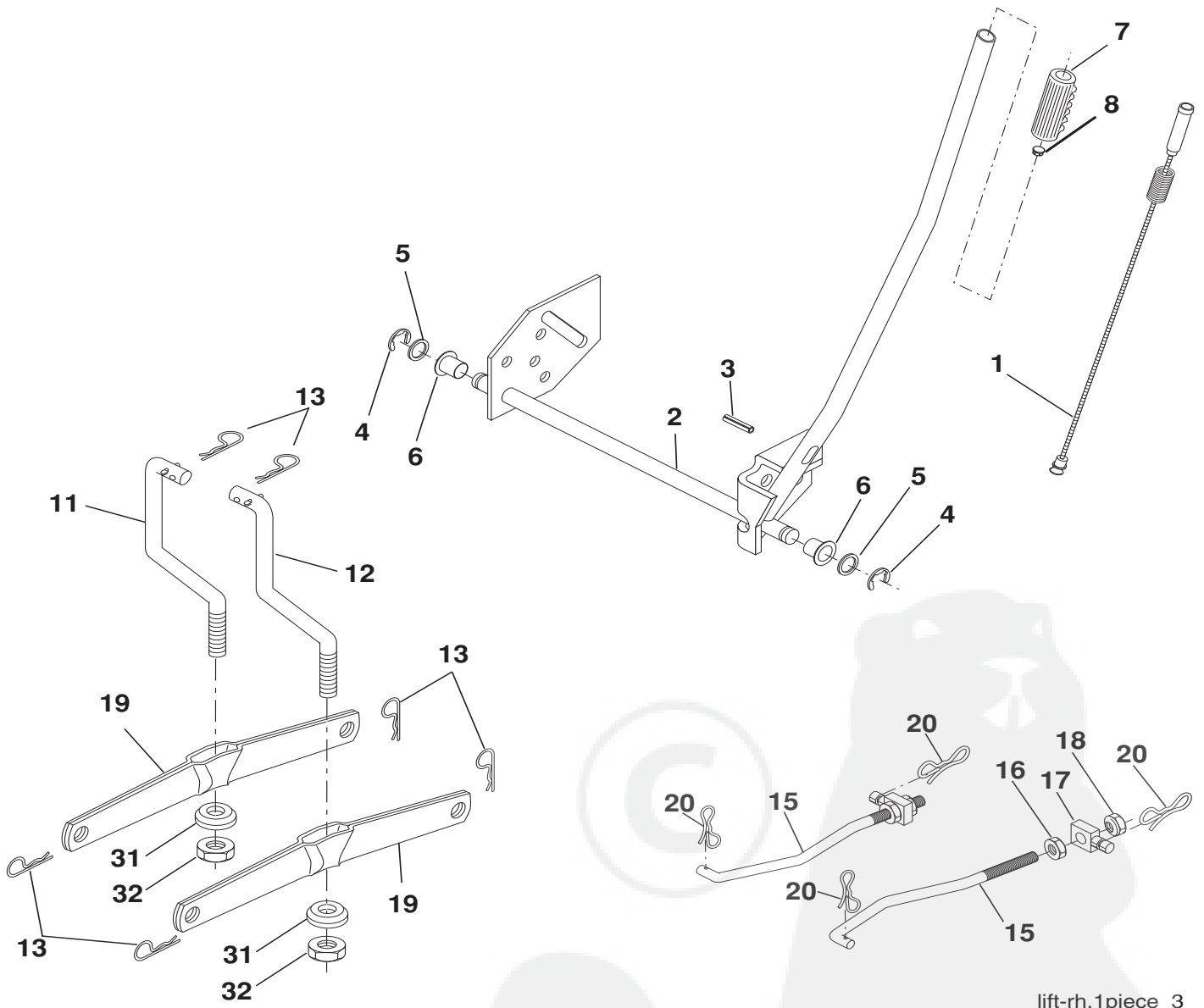

lift-rh.1piece_3

**TRACTOR-MODEL NO. LZ145H107AK(96011017703), PRODUCT NO. 960 11 01-77
MOWER LIFT**

KEY NO.	PART NO.	DESCRIPTION
1	532 40 50-07	Plunger Asm. Lift Lever
2	532 19 80-70	Shaft Asm Lift
3	532 18 88-22	Pin Groove
4	812 00 00-02	E Ring #5133-62
5	819 21 16-21	Washer 21/32 x 1 x 21 Ga.
6	532 12 01-83	Bearing Nylon Blk 629 Id
7	532 10 94-13	Grip Handle
8	532 12 45-26	Button Plunger
11	532 13 98-65	Link Lift LH
12	532 13 98-66	Link Lift RH
13	532 12 46-70	Retainer Spring
15	532 17 32-88	Link Front
16	873 35 08-00	Nut Jam Hex 1/2-13 unc
17	532 17 56-89	Trunnion Blk Zinc
18	873 80 08-00	Nut Lock W/wsh 1/2-13 unc
19	532 13 98-68	Arm Suspension Rear
20	532 19 42-09	Pin Cotter 7/16 Bow Tie Lock
31	532 16 98-65	Bearing pvt. Lift
32	873 54 06-00	Nut Crownlock 3/8-24

NOTE: All component dimensions given in U.S. inches
1 inch = 25.4 mm

GARANTIE LIMITÉE

Le Fabricant garantit son produit à l'acheteur initial comme exempt de tout défaut de matière et de fabrication. Pendant un (1) an, à compter de la date d'achat de la part de l'acheteur initial, nous réparerons où remplacerons à notre choix, gratuitement, toute pièce, sur laquelle nous estimerons qu'il existe un défaut de matière ou de fabrication. Cette garantie est soumise aux limitations suivants et exceptions:

1. Cette garantie ne couvre pas le moteur, la transmission/composants de transmission, la batterie (sauf comme mentionnée ci-dessous) ou les pièces détachées. Veuillez-vous consulter la garantie applicable du fabricant des articles.
2. L'acheteur est responsable de coût du transport de tous les équipements actionnés par moteur ou les accessoires. L'acheteur est responsable de coût aussi du transport de toutes les pièces (couvertes par cette garantie) soumiées pour remplacement à moins que Electrolux Home Products demande à l'acheteur de renvoyer les pièces.
3. Garantie de la batterie: Pour les produits équipés d'une batterie, nous remplacerons, gratuitement, toute batterie estimée défectueuse pendant les quatre-vingt-dix (90) jours initiaux suivant l'achat. Après quatre-vingt-dix (90) jours, nous échangerons la batterie, le coût pour vous être 1/12 du prix d'une nouvelle batterie pour chaque mois complet à compter de la date d'achat initial. La batterie doit être entretenue selon les directives données dans la documentation appropriée.
4. La période de garantie applicable aux produits proposés en location ou à des fins commerciales est limitée à quarante-cinq (90) jours à compter de la date d'achat initial.
5. Cette garantie ne s'applique qu'aux produits correctement assemblés, réglés, utilisés et entretenus conformément aux instructions données dans la documentation appropriée. Cette garantie ne s'applique pas aux produits qui ont été modifié, utilisés incorrectement, abusés, mal assemblés, mal installés ou endommagés lors de la livraison ou usage normal.
6. Exclusions: Les courroies, lames, moyeux de lames, usage normal, réglages normaux, quincaillerie ordinaire, et entretien normal sont exclus de cette garantie.
7. En cas de problème entrant dans le cadre de cette garantie, veuillez contacter votre point de vente, en indiquant le numéro du modèle, le numéro de série, la date d'achat de votre machine. Cette garantie ne s'applique pas aux dommages accidentels. Toutes garanties implicites sont limitées aux mêmes périodes de temps. Ou contactez:

E.M. Services
54 Rue Lambrechts
92400 Courbevoie - France
Telephone: (1) 46678078
Fax: (1) 46678095

CETTE GARANTIE NE S'APPLIQUE PAS AUX DOMMAGES ACCIDENTELS. TOUTES GARANTIES IMPLICITES SONT LIMITÉES AUX MEMES PERIODES DE TEMPS.



LAZER®