

**REPAIR PARTS MANUAL**  
**MODEL NO. 277321**  
**Lawn Tractor**

---

**CRAFTSMAN®**

# HOW TO USE THIS MANUAL

This manual is designed to provide the customer with a means to identify the parts on his/her tractor when ordering repair parts. The illustrations may or may not represent the actual assemblies; therefore, it is not recommended to use this manual as a guide to assemble or disassemble the tractor. Some hardware and parts are drawn larger in order to more readily identify them.

Each tractor has its own model number.

The model number for your tractor can be found on the fender under the seat.

When ordering parts, always give the following information:

- Product - "Tractor"
- Model Number - "277321"
- Part Number
- Part Description

## TABLE OF CONTENTS

SCHEMATIC .....	3
ELECTRICAL.....	4-5
CHASSIS.....	6-7
DRIVE.....	8-9
STEERING .....	10-11
SEAT .....	12
DECALS.....	13
ENGINE.....	14-15
MOWER LIFT .....	16-17
MOWER DECK .....	18-19
TRANSAXLE.....	20-21
ENGINE BREAKDOWN.....	22-27
WARRANTY .....	28

# TRACTOR- -MODEL NO. 917. 277321

## SCHEMATIC

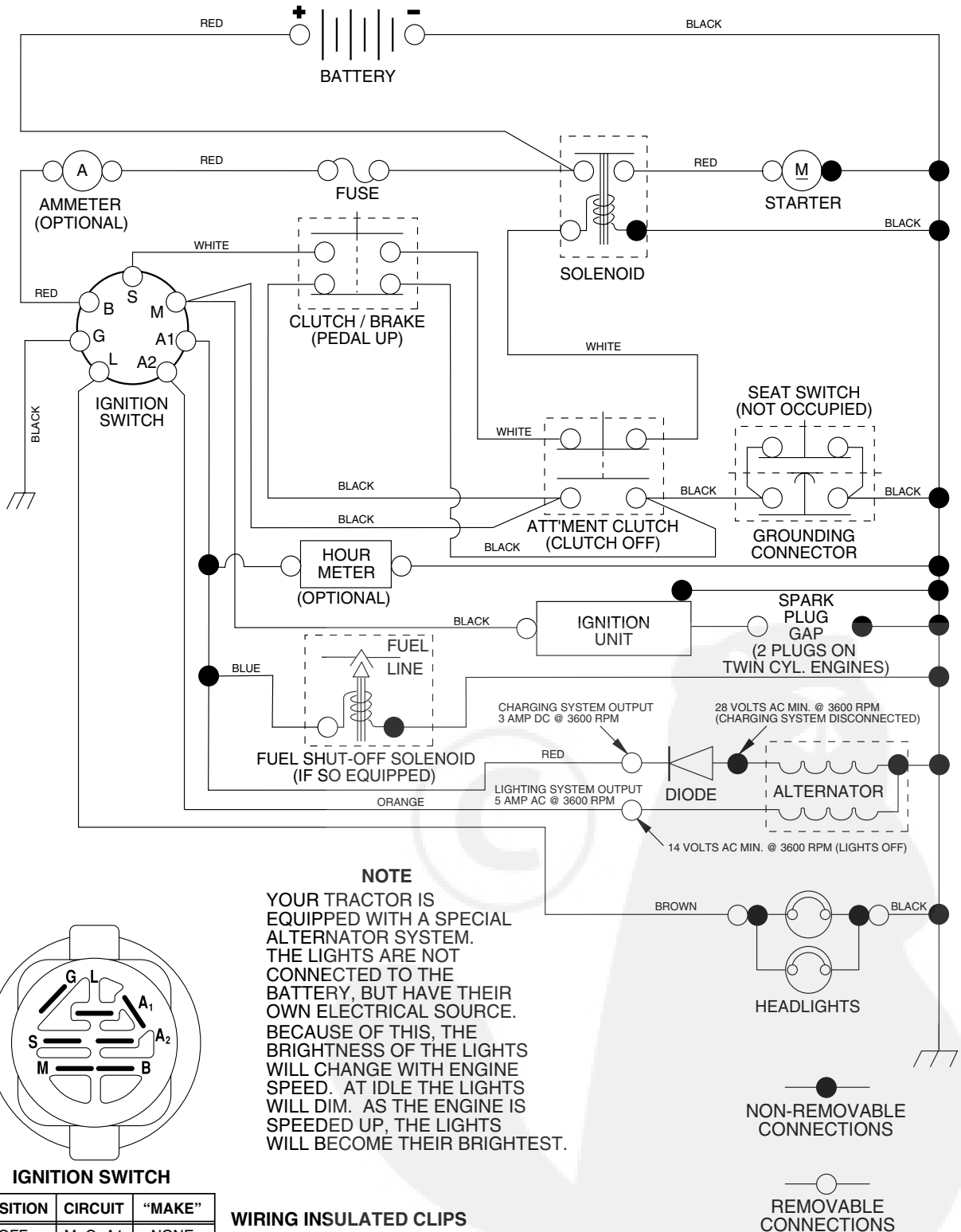

# REPAIR PARTS

TRACTOR- -MODEL NO. 917. 277321

## ELECTRICAL

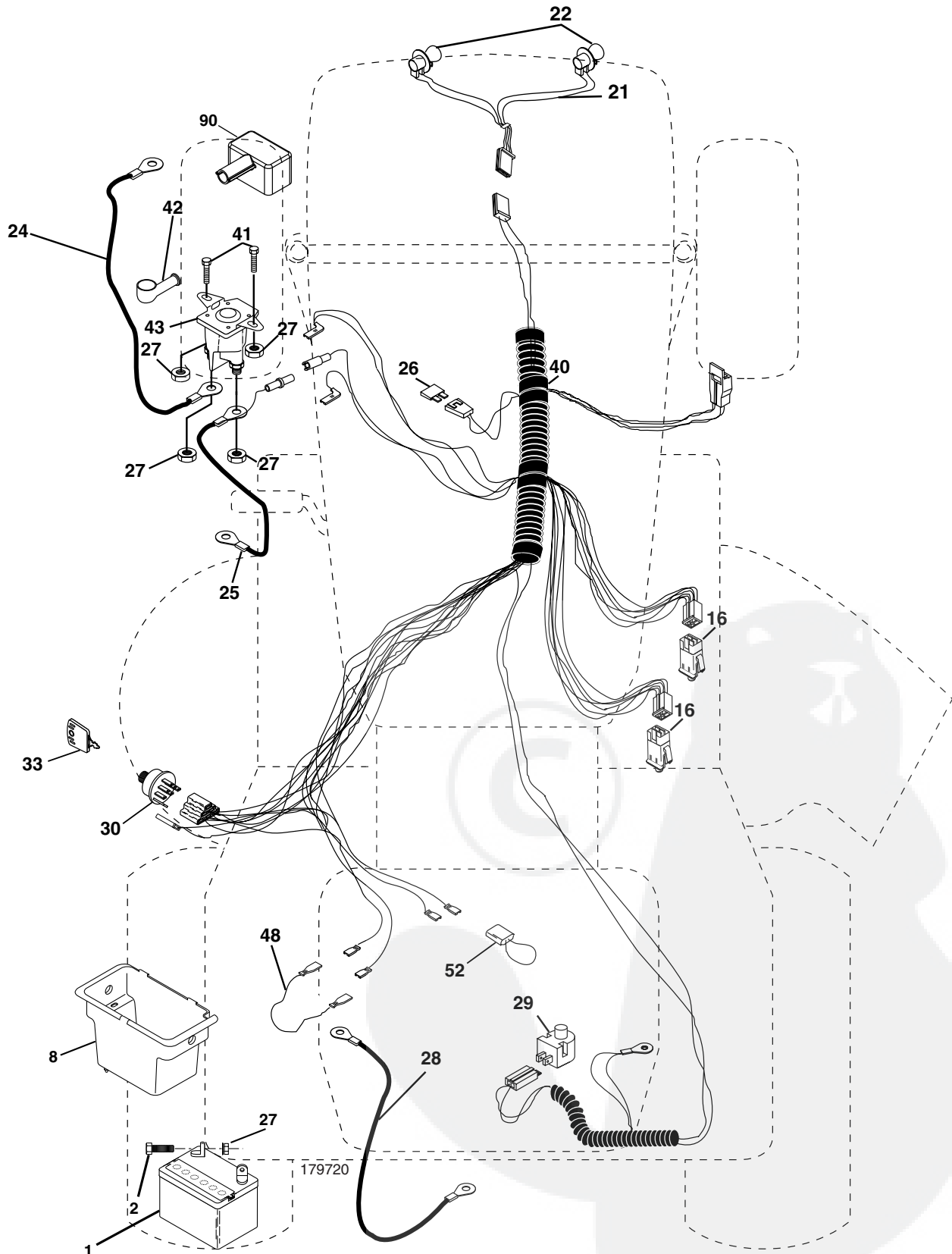

# REPAIR PARTS

TRACTOR- -MODEL NO. 917. 277321

## ELECTRICAL

KEY NO.	PART NO.	DESCRIPTION
1	163465	Battery
2	74760412	Bolt Hex Hd 1/4-20 unc x 3/4
8	176689	Box Battery Fender
16	176138	Switch, Interlock
21	175688	Harness Asm Light W/4152j
22	4152J	Bulb Light #1156
24	4799J	Cable Battery 6 Ga. 11" red
25	146147	Cable Battery 6 Ga. w/16 wire red
26	175158	Fuse 20 AMP
27	73510400	Nut, Keps Hex 1/4-20 unc
28	4207J	Cable Ground 6 Ga. 12" black
29	121305X	Switch Plunger Nc Gray
30	175566	Switch Ign
33	140403	Key Ign Molded Craftsman
40	179720	Harness Ign
41	71110408	Bolt Blk. Fin Hex 1/4-20 Unc x 1/2
42	131563	Cover Terminal Red
43	178861	Solenoid
48	140844	Ammeter Adapter
52	141940	Protection Wire Loop
90	180499	Cover Battery Terminal

**NOTE:** All component dimensions give in U.S. inches  
1 inch = 25.4 mm

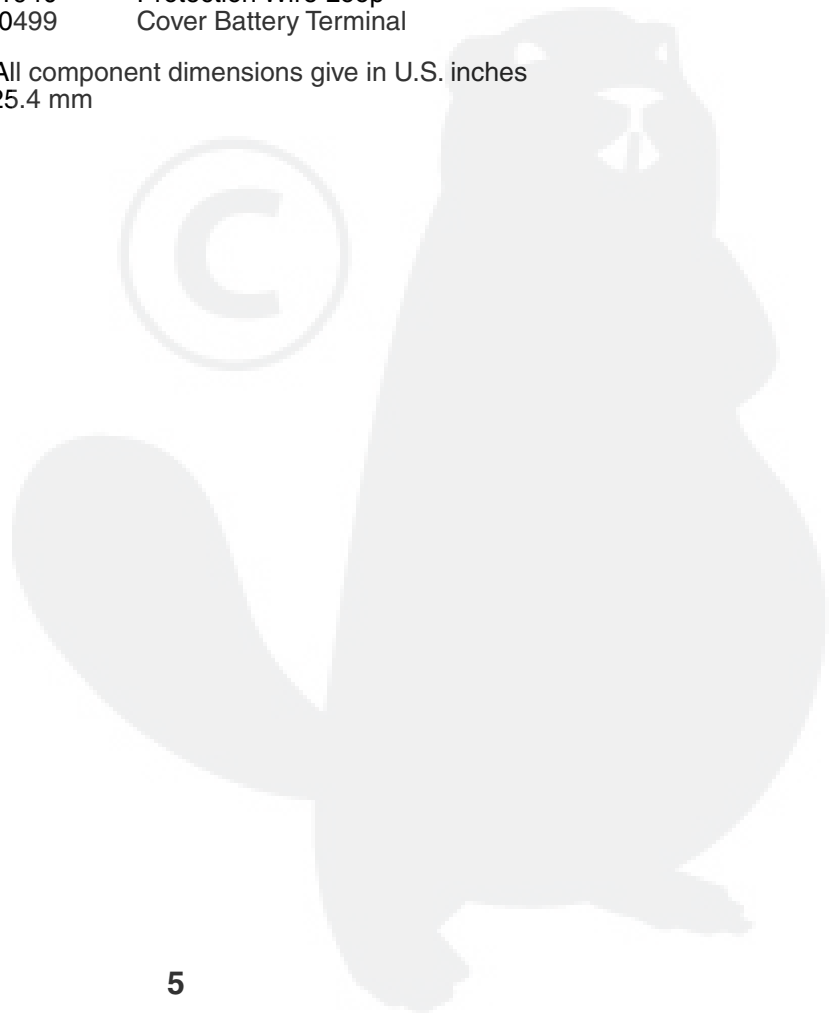
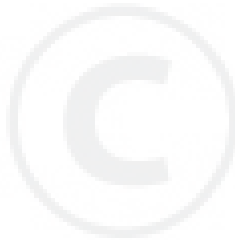

# REPAIR PARTS

## TRACTOR- -MODEL NO. 917. 277321

### CHASSIS AND ENCLOSURES

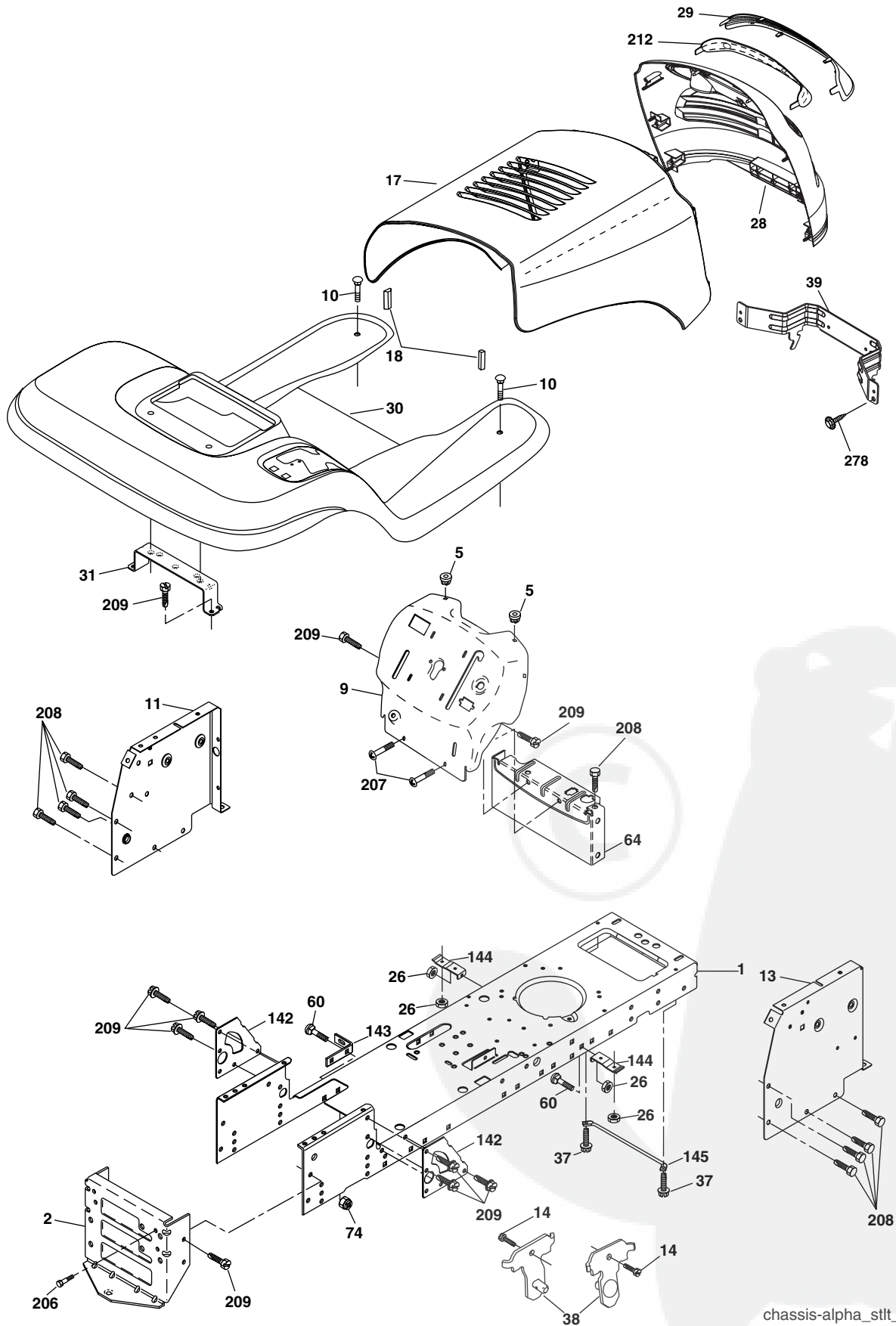

chassis-alpha\_stlit\_1

# REPAIR PARTS

## TRACTOR- -MODEL NO. 917. 277321

### CHASSIS AND ENCLOSURES

KEY NO.	PART NO.	DESCRIPTION
1	174619	Chassis Stamping
2	176554	Drawbar
5	155272	Bumper Hood/Dash
9	187845X013	Dash
10	STD533710	Bolt, Carriage 3/8-16 x 1
11	174996	Panel, Dash, L.H.
13	172105X010	Panel, Dash, R.H.
14	17490608	Screw Thdrol 3/8-16 x 1/2
17	187559X558	Hood Assembly Laser
18	184921	Bumper Extrusion
26	STD541437	Nut
28	187598	Grille Lens Asm (Include Key #'s 29 and 212)
29	187567X599	Lens, Laser
30	188571X558	Fend/Ftrest Pnt STLT
31	139976	Bracket, Fender Support
37	17490508	Screw Thdrol 5/16-18 x 1/2 Tyt
38	175710	Bracket Asm. Pivot Mower Rear
39	187568	Bracket Pivot
60	72140606	Bolt Rdhd Sqnk 3/8-16 unc x 3/4
64	154798	Dash Lower STLT
74	73680600	Nut Crownlock 3/8-16 unc
142	175702	Plate Reinforcement STLT
143	186689	Bracket Swaybar Chassis
144	175582	Bracket Pnt Footrest STLT
145	156524	Jod Pivot Chassis/Hood
206	170165	Bolt Shoulder 5/16 -18 TT
207	17670508	Screw Thdrol 5/16-18 x 1/2 TYTT
208	17670608	Screw Thdrol 3/8-16 x 1/2
209	17000612	Screw Thdrol 3/8-16 x 3/4
212	187569	Insert Lens Reflective
278	191611	Screw 10 x 3/4 Single Lead-Hex
--	5479J	Plug, Button

**NOTE:** All component dimensions given in U.S. inches  
1 inch = 25.4 mm

# REPAIR PARTS

TRACTOR- -MODEL NO. 917. 277321

## DRIVE

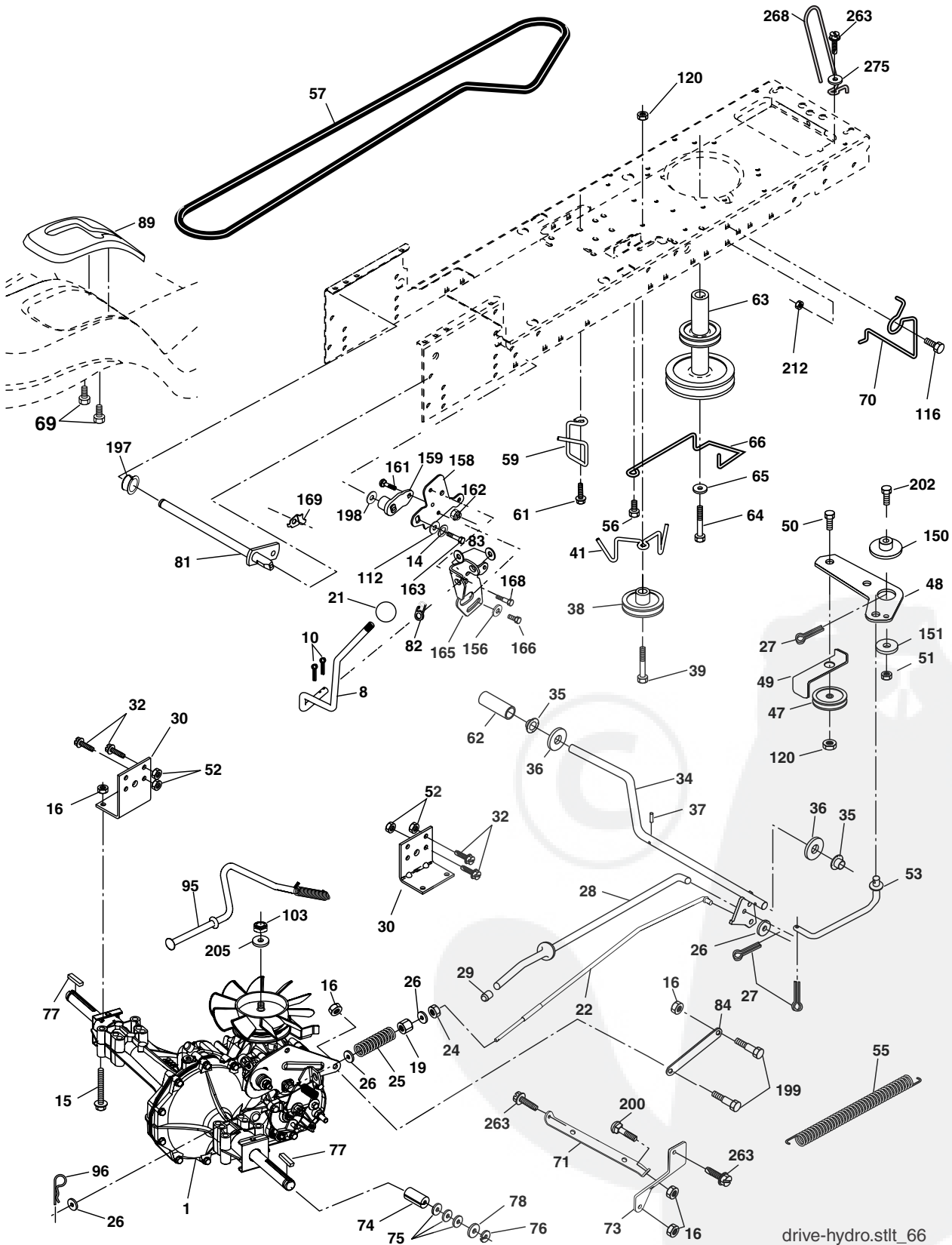

drive-hydro.stlt\_66



# REPAIR PARTS

## TRACTOR- -MODEL NO. 917. 277321

### DRIVE

KEY NO.	PART NO.	DESCRIPTION	KEY NO.	PART NO.	DESCRIPTION
1	-----	Transmission (See Breakdown) Hydro Gear Model 322-0510	70	180218	Guide, Belt, Mower Drive RH
8	165866	Rod, Shift	71	169183	Strap, Torque, Lh
10	STD561210	Pin, Cotter 1/8 x 1	73	169182	Strap, Torque, Rh
14	STD551125	Washer Lock 1/4	74	137057	Spacer, Axle
15	74490544	Bolt Hex Flghd 5/16-18 Gr. 5	75	121749X	Washer 25/32 x 1-1/4 x 16 Ga.
16	73800500	Nut, Lock Hex w/Ins 5/16-18 unc	76	12000001	Ring, E
19	73800600	Nut Lock Hex w/Ins 3/8-16	77	123583X	Key, Square
21	130564	Knob	78	121748X	Washer 25/32 x 1-5/8 x 16 Ga.
22	169498	Rod, Brake	81	165596	Shaft Asm Cross
24	73350600	Nut	82	165711	Spring, Torsion
25	106888X	Spring, Rod, Brake	83	19171216	Washer 17/32 x 3/4 x 16 Ga.
26	19131316	Washer 13/32 x 13/16 x 16 Ga.	84	169843	Link Transaxle
27	STD561210	Pin, Cotter 1/8 x 3/4	89	188309X428	Console, Shift
28	175765	Rod, Parking Brake	95	170201	Control Asm Bypass Hydro
29	71673	Cap, Parking Brake	96	STD624003	Spring, Retainer 1"
30	174973	Bracket, Transmission	103	73940800	Nut Hex Jam Toplock 1/2-20 unf
32	74760512	Bolt Hex 5/16-18 unc x 3/4	112	19091210	Washer 9/32 x 3/4 x 10 Ga.
34	175578	Shaft, Foot Pedal	116	72140608	Bolt Rdhd Sq Neck 3/8-16 x 1
35	120183X	Bearing, Nylon	120	73900600	Nut Lock Flg 3/8-16
36	19211616	Washer	150	175456	Spacer Retainer
37	1572H	Pin, Roll	151	19133210	Washer 13/32 x 2 x 10
38	179114	Pulley, Composite	156	166002	Washer 5/16 x 1.0 x 1.25
39	72110622	Bolt	158	165589	Bracket Shift Mount
41	175556	Keeper, Belt, Idler	159	183900	Hub Shift
47	127783	Pulley, Idler, V-Belt	161	72140406	Bolt Rdhd Sqnk 1/4-20 x 3/4 Gr. 5
48	154407	Bellcrank Clutch Grnd Drustl	162	73680400	Nut Crownlock 1/4-20 unc
49	123205X	Retainer, Belt	163	74780416	Bolt Hex Fin 1/4-20 x 1
50	72110612	Bolt Carr. Sh 3/8-16 x 1-1/2 Gr. 5	165	165623	Bracket Pivot Lever
51	STD541437	Nut	166	17490510	Screw 5/16 x 18 x 5/8
52	STD541431	Nut Crownlock 5/16-18	168	165492	Bolt Shoulder 5/16-18 x .561
53	105710X	Link, Clutch	169	165580	Plate Fastener Cross Shaft
55	105709X	Spring, Return, Clutch	197	169613	Nyliner Snap-In
56	17060620	Screw 3/8-16 x 1-1/4	198	169593	Washer Nyliner
57	140294	V-Belt, Drive	199	169612	Bolt Shoulder 5/16-18 unc
59	169691	Keeper, Belt, Center	200	72140508	Bolt RdHd Sqnk 5/16-18 unc x 1
61	17120614	Screw 3/8-16 x .875	202	72110614	Bolt Carr. Sh 3/8-16 x 1-3/4 Gr. 5
62	8883R	Cover, Pedal	205	19171616	Washer 17/32 x 1 x 16 Ga.
63	180219	Pulley, Engine	212	145212	Nut Hex Flange Lock
64	173937	Bolt Hex 7/16 x 4 Gr. 5	263	17000612	Screw 3/8-16 x 3/4
65	10040700	Washer	268	182402	Guard Muffler
66	154778	Keeper, Belt Engine Hydro	275	19131614	Washer 13/32 x 1 x 14 Ga.
69	142432	Screw Hex Wsh Hi-Lo 1/4 x 1/2 unc			

**NOTE:** All component dimensions given in U.S. inches  
1 inch = 25.4 mm

# REPAIR PARTS

TRACTOR- -MODEL NO. 917. 277321

## STEERING ASSEMBLY

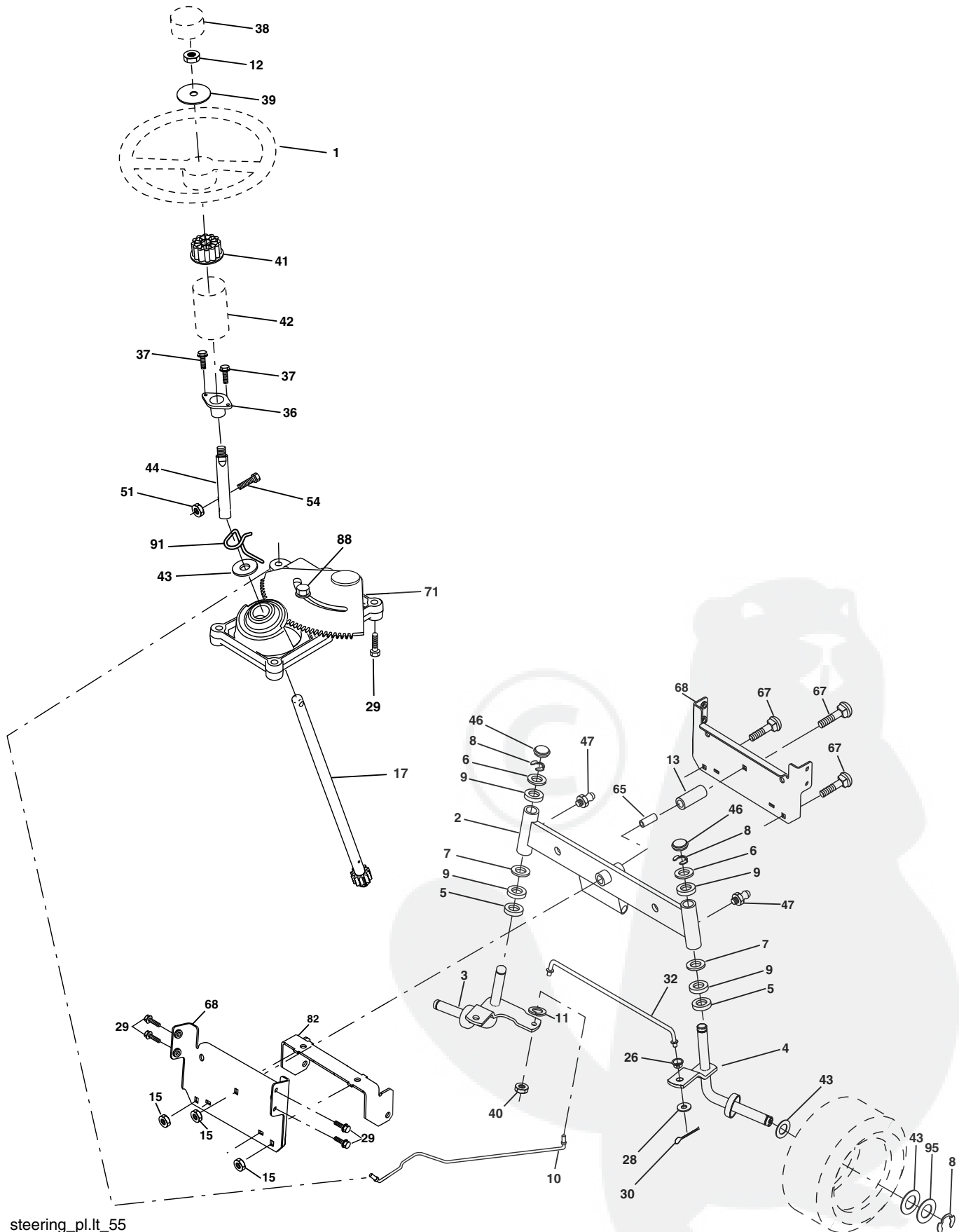

steering\_pl.lt\_55

# REPAIR PARTS

## TRACTOR- -MODEL NO. 917. 277321

### STEERING ASSEMBLY

KEY NO.	PART NO.	DESCRIPTION
1	140044X428	Steering Wheel
2	175131	Axle Assembly STMP Dropped STL
3	169840	Spindle Assembly, L.H.
4	169839	Spindle Assembly, R.H.
5	6266H	Bearing, Race, Thrust, Hardened
6	121748X	Washer 25/32 x 1-5/8 x 16 Ga.
7	19272016	Washer 27/32 x 1-1/4 x 16 Ga.
8	12000029	Ring, Klip
9	3366R	Bearing, Steering Column
10	175121	Draglink
11	10040600	Washer, Lock
12	73940800	Nut Hex Jam Toplock 1/2-20 unf
13	136518	Spacer Brg Axle Front
15	145212	Nut, Hexflange Lock
17	180641	Shaft Assembly, Steering
26	126847X	Bushing, Link, Drag
28	19131416	Washer 13/32 x 7/8 x 16 Ga.
29	17000612	Screw 3/8-16 x 3/4
30	STD561210	Pin
32	130465	Rod, Tie
36	155099	Bushing, Steering
37	152927	Screw
38	140045X428	Insert, Steering Wheel
39	19183812	Washer 9/16 x 2-3/8
40	73540600	Nut Crownlock 3/8-24
41	186737	Adaptor, Steering Wheel
42	145054x428	Boot, Steering Shaft
43	121749X	Washer 25/32 x 1-1/4 x 16 Ga.
44	180640	Extension Shaft Steering
46	121232X	Cap, Spindle
47	183226	Fitting, Grease
51	73540400	Nut Crownlock 1/4-28
54	71130420	Bolt Hex 1/4-28 UNF x 1-1/4 Gr. 8
65	160367	Spacer Brace Axle
67	72110618	Bolt Rdhd Sqnk 3/8-16 x 2-1/4
68	169827	Axle, Brace
71	175146	Steering Asm
82	169835	Bracket Susp Chassis Front
88	175118	Bolt Shoulder 7/16-20
91	175553	Clip Steering
95	188967	Washer Harden .793 x 1.637 x .060

**NOTE:** All component dimensions given in U.S. inches  
1 inch = 25.4 mm

# REPAIR PARTS

## TRACTOR- -MODEL NO. 917. 277321

### SEAT ASSEMBLY

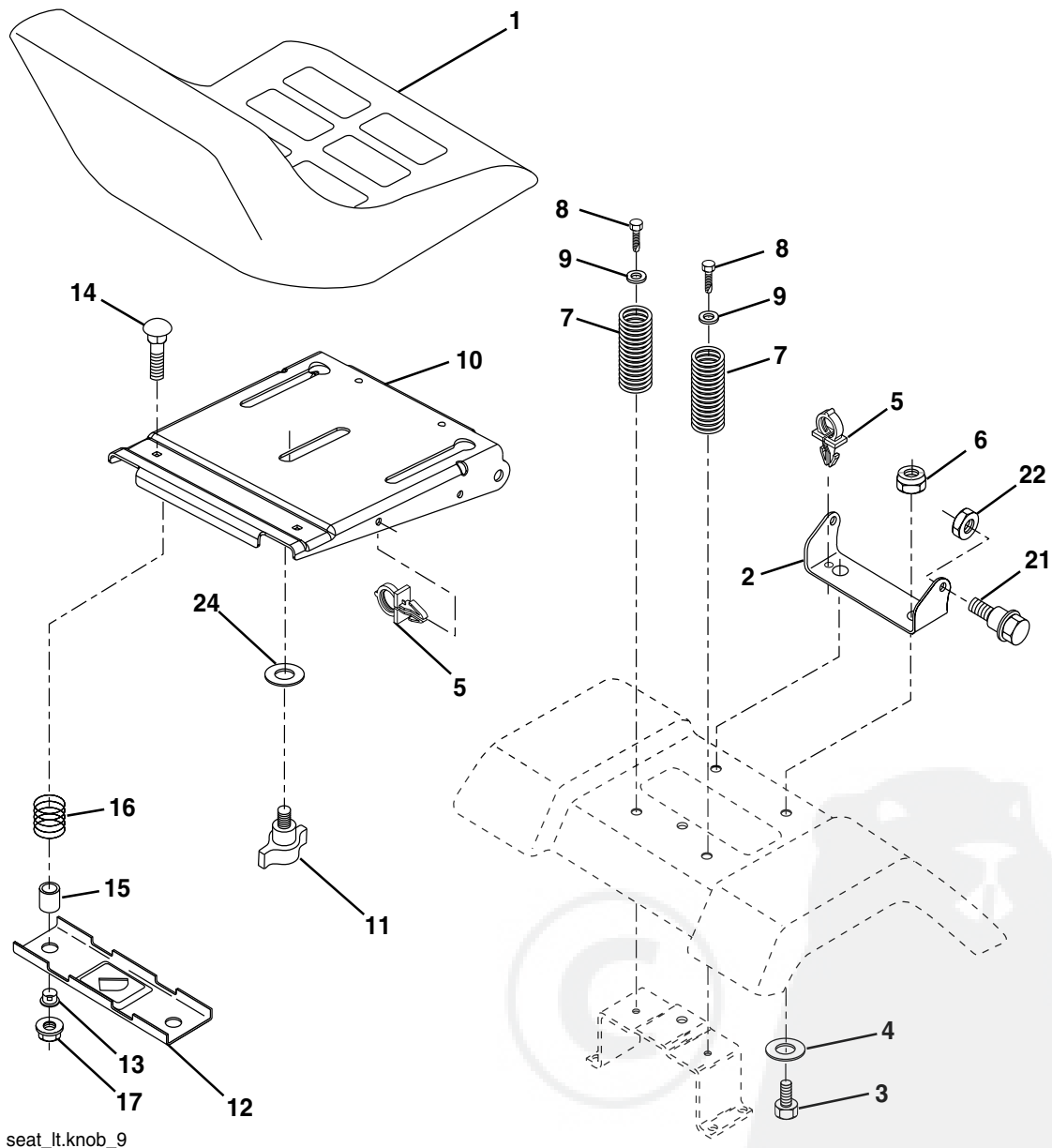

seat\_lt.knob\_9

KEY NO.	PART NO.	DESCRIPTION
1	188716	Seat
2	180166	Bracket, Pivot, Seat
3	71110616	Bolt
4	19131610	Washer 13/32 x 1 x 10 Ga.
5	145006	Clip, Push-In Hinged
6	STD541437	Nut
7	124181X	Spring, Seat
8	17000616	Screw 3/8-16 x 1-1/2
9	19131614	Washer 13/32 x 1 x 14 Ga.
10	180186	Pan, Seat
11	166369	Knob Seat
12	121246X	Bracket, Switch Mounting

KEY NO.	PART NO.	DESCRIPTION
13	121248X	Bushing, Snap
14	72050412	Bolt, Carriage 1/4-20 x 1-1/2
15	134300	Spacer, Split .28 x .88
16	121250X	Spring
17	123976X	Locknut, Flange 1/4 Gr. 5
21	171852	Bolt, Shoulder 5/16-18 unc
22	STD541431	Nut
24	19171912	Washer 17/32 x 1-3/16 x 12 Ga.

**NOTE:** All component dimensions given in U.S. inches  
1 inch = 25.4 mm

# REPAIR PARTS

## TRACTOR- -MODEL NO. 917. 277321

### DECALS

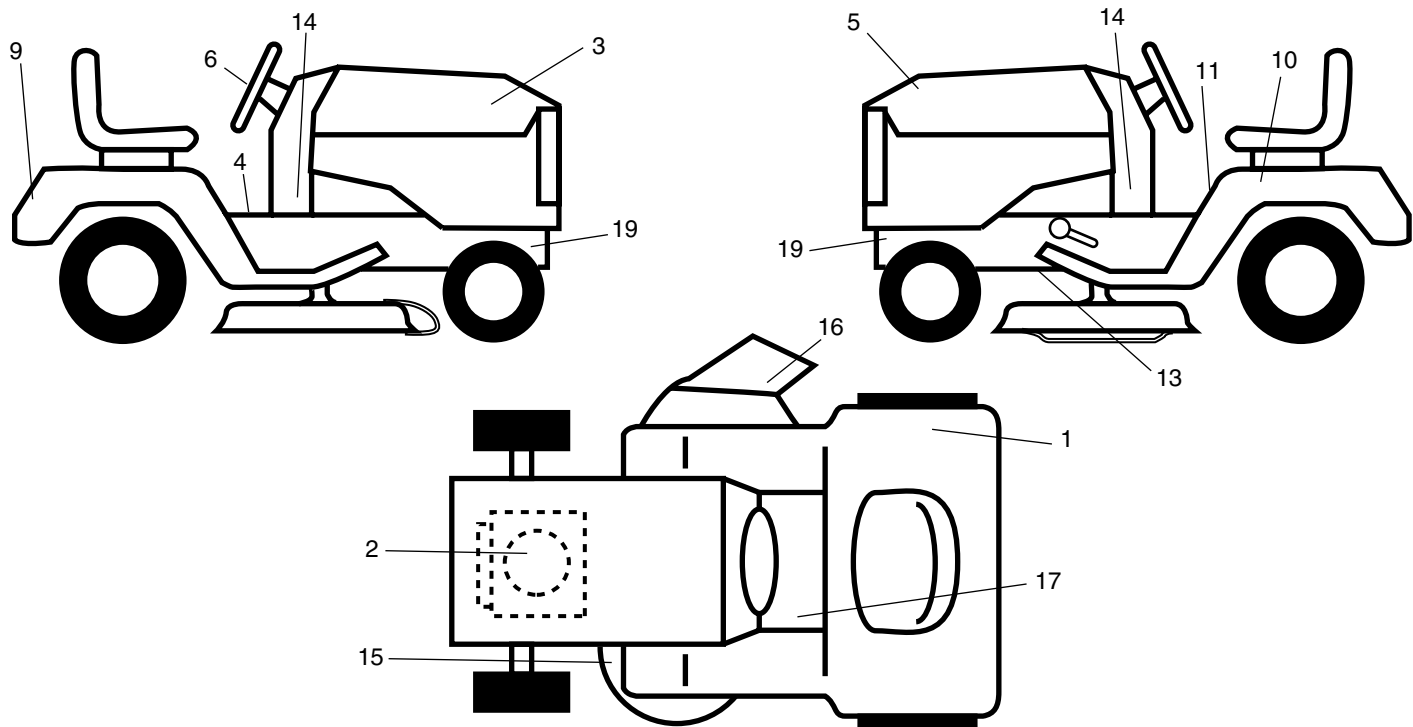

KEY NO.	PART NO.	DESCRIPTION
1	180432	Decal, Fender DB/CE
2	184847	Decal, HP Engine
3	190959	Decal, Hood RH
4	140837	Decal, Brake Parking
5	190960	Decal, Hood LH
6	172275	Decal, Steering Whl.
9	184899	Decal, Fender
10	145005	Decal, Battery, Dngr/Psn Eng
11	145498	Decal, Read Owner's Manual
13	146046	Decal, V-Belt Dr Sch Tractor
14	181685	Decal, Panel Dash

KEY NO.	PART NO.	DESCRIPTION
15	136832	Decal, V-Belt Sch
16	182166	Decal, Cutfinger
17	159737	Decal, Brake/Clutch Symbol
19	159736	Decal, Chassis Hot Muffler
--	162598	Decal Drawbar Load Limit
--	138311	Decal, Lift Handle
--	166960	Decal, Bypass
--	184310X428	Pad Footrest LH STLT
--	184311X428	Pad Footrest RH STLT
--	192222	Operator's Manual, Euro
--	192223	Operator's Manual, Scan
--	192224	Manual, Parts

### WHEELS & TIRES

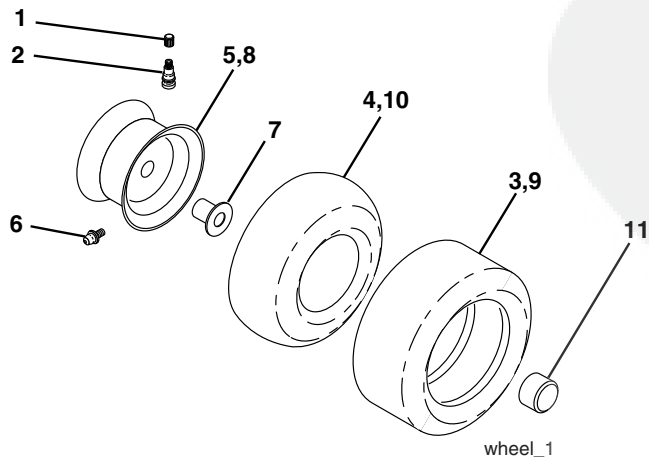

KEY NO.	PART NO.	DESCRIPTION
1	59192	Valve Cap, Tire
2	65139	Stem, Valve
3	106222X	Tire, Front
4	59904	Tube, Front Tire (Not Provided, Service Item Only)
5	106732X624	Rim, Front
6	278H	Fitting, Grease (Front Wheel Only)
7	9040H	Bearing, Flange (Front Wheel Only)
8	106108X624	Rim, Rear
9	124635X	Tire, Rear
10	7152J	Tube, Rear Tire (Not Provided, Service Item Only)
11	104757X428	Cap, Axle
--	144334	Sealant, Tire 10 oz.

**NOTE:** All component dimensions given in U.S. inches  
1 inch = 25.4 mm

# REPAIR PARTS

TRACTOR- -MODEL NO. 917. 277321

## ENGINE

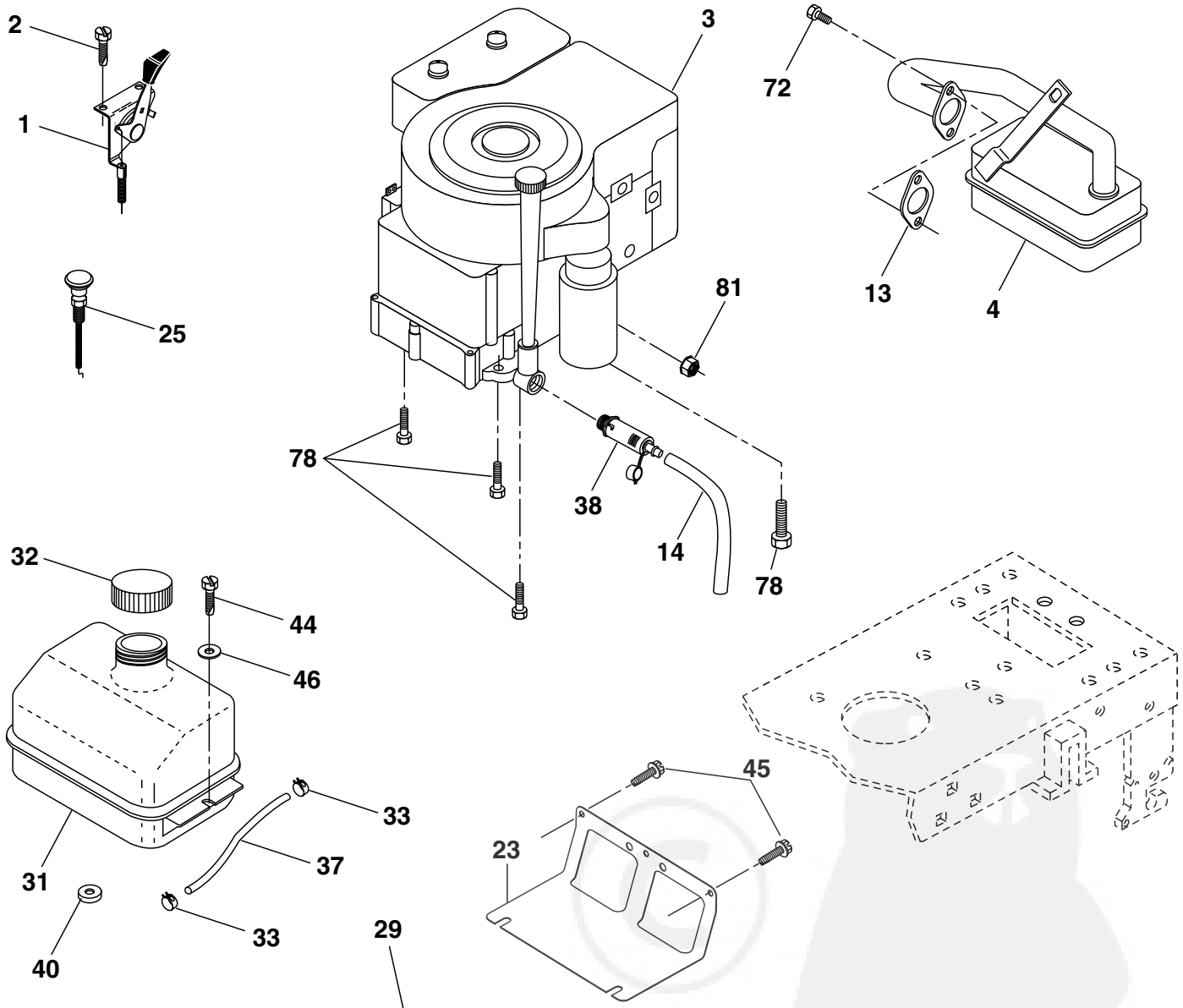

**OPTIONAL EQUIPMENT**  
**Spark Arrester**

engine-bs.1cyl\_37

# REPAIR PARTS

## TRACTOR- -MODEL NO. 917. 277321

### ENGINE

KEY NO.	PART NO.	DESCRIPTION
1	170551	Control, Throttle
2	17720408	Screw, Hex Head, Thread Cutting 1/4-20 x 5/8
3	- - - - -	Engine, (See Breakdown) Briggs Model No. 282H07-0239-E1
4	137352	Muffler
13	165291	Gasket
14	148456	Tube Drain Oil Easy
23	169837	Shield Brn/Dbr Guard
25	187770X428	Control, Choke
29	137180	Arrestor, Spark
31	184900	Tank, Fuel
32	140527	Cap Assembly Fuel
33	123487X	Clamp, Hose
37	137040	Line, Fuel
38	181654	Plug, Drain Oil Easy
40	124028X	Bushing Snap
44	17670412	Screw, Hex Washer Head, Thd., Roll. 1/4-20 x 3/4
45	17000612	Screw Hex Wsh Thdr 3/8-16 x 3/4
46	19091416	Washer 9/32 x 7/8 x 16 Ga.
72	183906	Screw Socket Head 5/16-18 x 1
78	17060620	Screw 3/8-16 x 1-1/4
81	73510400	Nut Keps Hex 1/4-20 unc

**NOTE:** All component dimensions given in U.S. inches 1 inch = 25.4 mm

# REPAIR PARTS

TRACTOR- -MODEL NO. 917. 277321

## MOWER LIFT

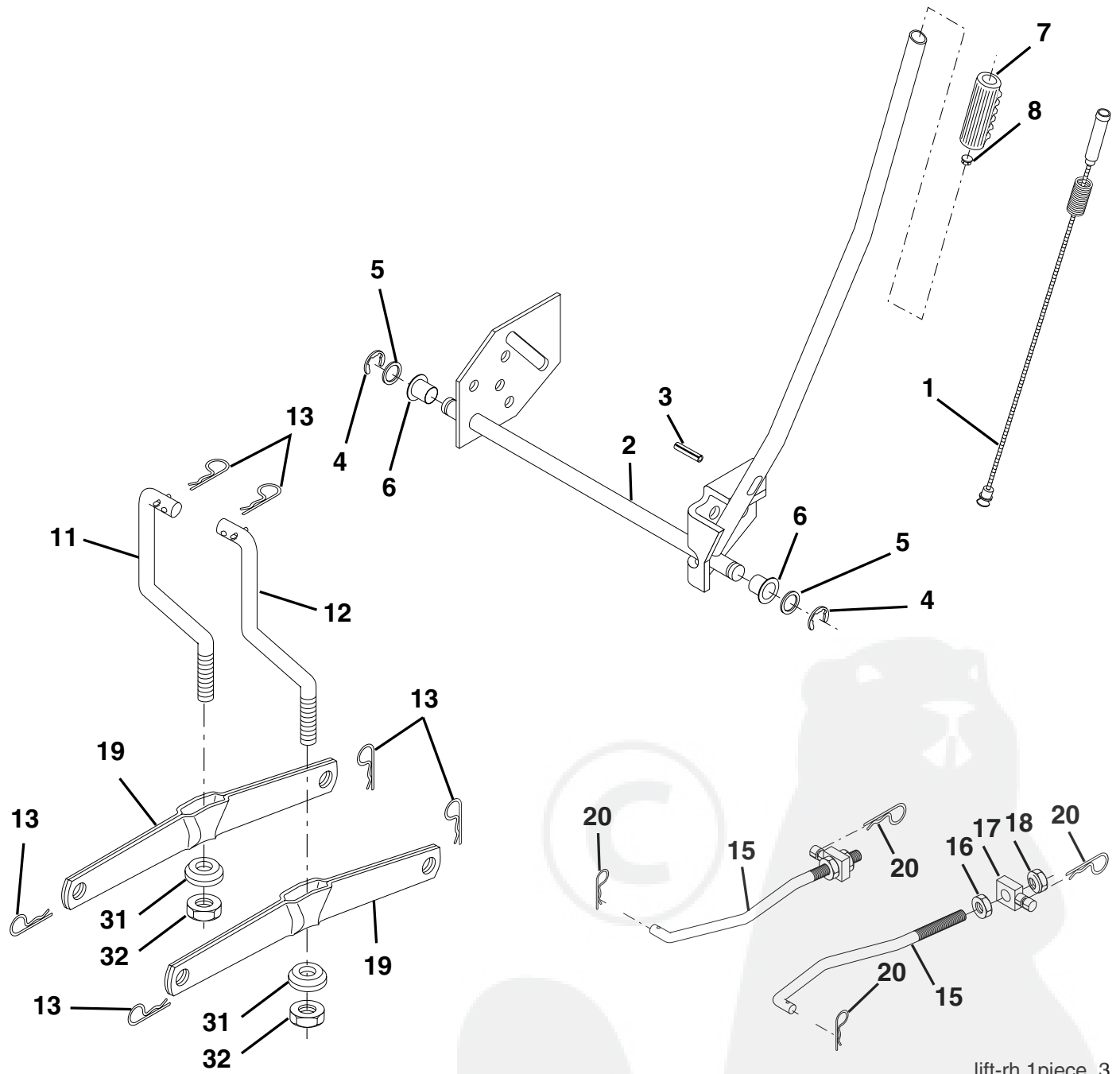

lift-rh.1piece\_3



# REPAIR PARTS

TRACTOR- -MODEL NO. 917. 277321

## MOWER LIFT

KEY NO.	PART NO.	DESCRIPTION
1	159460	Lift Lever Inner Wire Assembly
2	159471	Shaft Assembly, Lift
3	105767X	Pin, Groove
4	12000002	E-Ring
5	19211621	Washer 21/32 x 1 x 21 Ga.
6	120183X	Bearing, Nylon
7	125631X	Grip, Handle, Fluted
8	122365X	Button, Plunger, Red
11	139865	Link, Lift, L.H.
12	139866	Link, Lift, R.H.
13	STD624008	Retainer Spring
15	173288	Link, Front
16	73350800	Nut, Hex, Jam 1/2-13 unc
17	175689	Trunnion
18	73800800	Locknut, Hex, with Washer Insert 1/2-13 unc
19	139868	Arm, Suspension, Rear
20	163552	Retainer Spring
31	169865	Bearing, Pvt, Lift
32	73540600	Nut, Crownlock 3/8-24

**NOTE:** All component dimensions given in U.S. inches  
1 inch = 25.4 mm

# REPAIR PARTS

TRACTOR- -MODEL NO. 917. 277321

MOWER

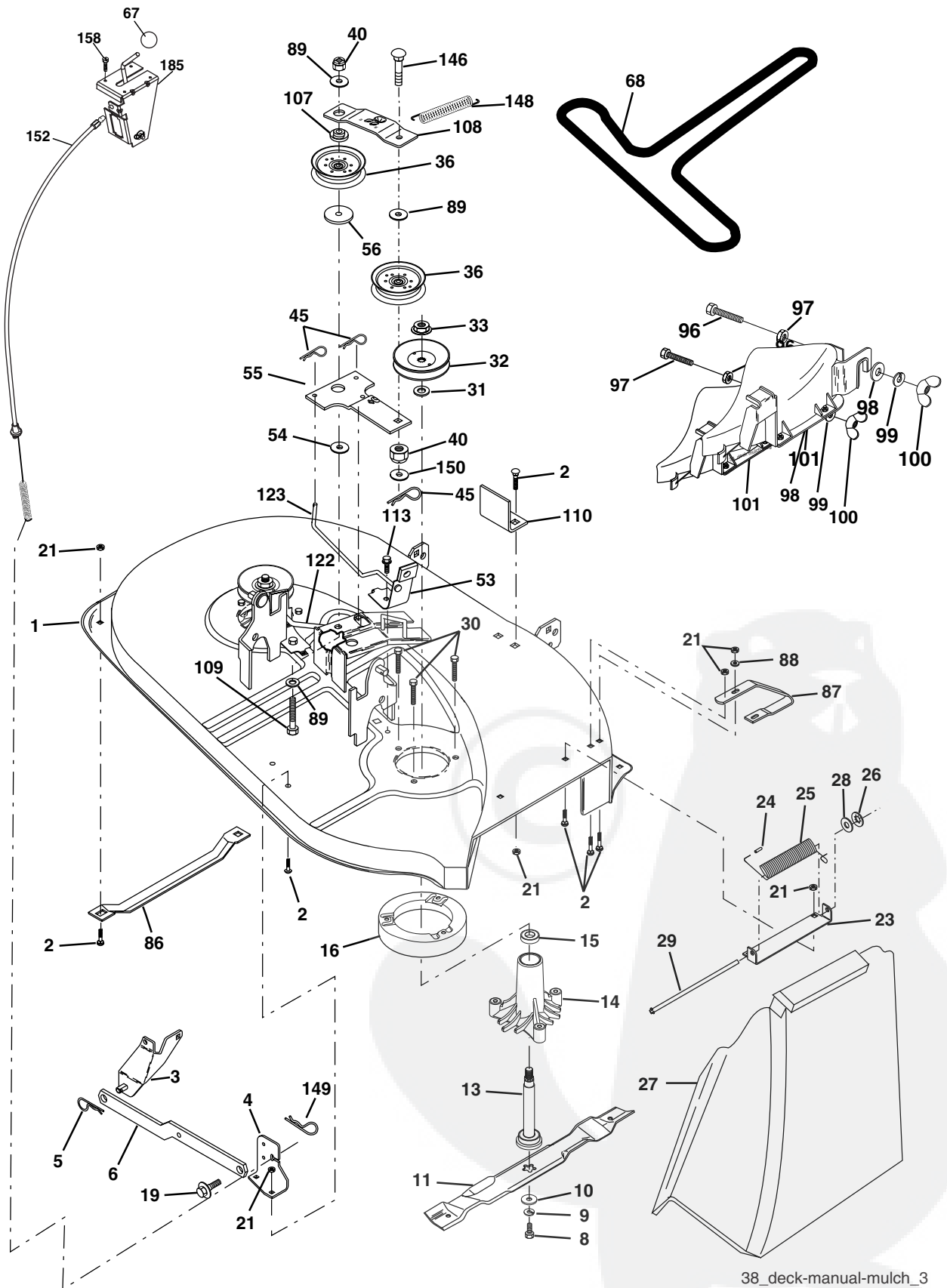

38\_deck-manual-mulch\_3

# REPAIR PARTS

## TRACTOR- -MODEL NO. 917. 277321

### MOWER

KEY NO.	PART NO.	DESCRIPTION	KEY NO.	PART NO.	DESCRIPTION
1	170280	Mower Housing Assembly	86	7631J	Runner, LH
2	72140506	Bolt, Carriage 5/16-18 x 3/4	87	128772	Runner, RH
3	138017	Bracket Asm. Fram Sway Bar	88	19111216	Washer 11/32 x 3/4 x 16 Ga.
4	169970	Bracket, Asm. Deck Sway Bar	89	19131311	Washer 13/32 x 13/16 x 11 Ga.
5	4939M	Retainer, Spring	92	73800600	Nut Lock Hex w/Ins. 3/8-16
6	178024	Bar Sway Deck	96	74930620	Bolt 3/8-16 x 1-1/4
8	850857	Bolt, Hex 3/8-24 x 1-1/4 Gr. 8	97	73930600	Nut Centerlock 3/8-16
9	10030600	Washer, Lock, Hlcl Sprg 3/8	98	19132016	Washer 13/32 x 1-1/4 x 16 Ga.
10	140296	Washer, Hard Blade Mower Vented (The following blades are available)	99	10040600	Washer Lock Hvy Hlcl Spr. 3/8
11	134148	Blade, 38" Mulching Std (For mulching mowers only)	100	135651	Nut Wing
13	137645	Shaft and Bearing Assembly (In- cludes Key Number 15)	101	132803	Cover Asm Mulching 38"
14	128774	Mandrel Housing, Vented	107	133502	Spacer, Retainer
15	110485X	Ball Bearing, Mandrel	108	133503	Stiffener, Idler Arm
16	174493	Stripper, Mower, Vented	109	74760640	Bolt, Hex Head 3/8-16 x2-1/2
19	132827	Bolt, Shoulder	110	142587	Upstop Deck Front 38"
21	73680500	Nut, Crownlock 5/16-18	113	17060512	Screw 5/16-18 x 3/4
23	137607	Bracket, Mower Deflector	122	131289	Rod, Brake, LH
24	105304X	Cap, Sleeve	123	169971	Rod, Brake, RH
25	123713X	Spring, Deflector	129	19131312	Washer 13/32 x 13/16 x 12 Ga.
26	110452X	Nut, Push	130	74780616	Bolt Fin Hex 3/8-16 unc x 1 Gr. 5
27	106736X428	Shield, Deflector	131	72140608	Bolt Rdhd Sqnk 3/8-16 unc x 1
28	19111016	Washer 11/32 x 3/4 x 16 Ga.	146	165891	Bolt Carriage Idler
29	106735X	Rod, Hinge	148	169022	Spring Return Idler
30	173984	Screw, Thdro	149	165898	Retainer Spring Yellow Zinc
31	187690	Washer, Spacer	150	19091210	Washer 9/32 x 3/4 x 10 Ga.
32	153532	Pulley, Mandrel	152	172758	Cable Clutch 38 In
33	178342	Nut, Flangelock 9/16	158	17720408	Screw Hex Thd Cut 1/4-20 x 1/2
36	131494	Pulley, Idler, Flat	185	188234	Head Asm. Cable Clutch
40	73680600	Nut Crownlock 3/8-16	--	130794	Mandrel Assembly (Includes Hous- ing, Shaft and Shaft Hardware Only-Pulley Not Included)
45	4497H	Retainer, Spring	--	181209	Replacement Mower, Complete (Std. Deck - Order separately mulcher cover components key nos. 96-101)
53	130840	Brake Assembly			
54	178515	Washer Hardened			
55	133840	Idler Arm Assembly			
56	165723	Spacer, Retainer			
67	149846	Knob			
68	180214	Belt			

**NOTE:** All component dimensions given in U.S. inches  
1 inch = 25.4 mm

# REPAIR PARTS

## TRACTOR- -MODEL NO. 917. 277321

### HYDRO TRANSAXLE - MODEL NUMBER 322-0510

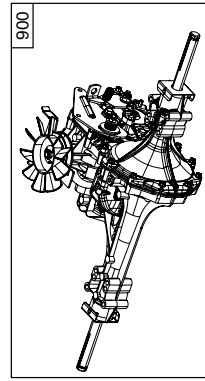
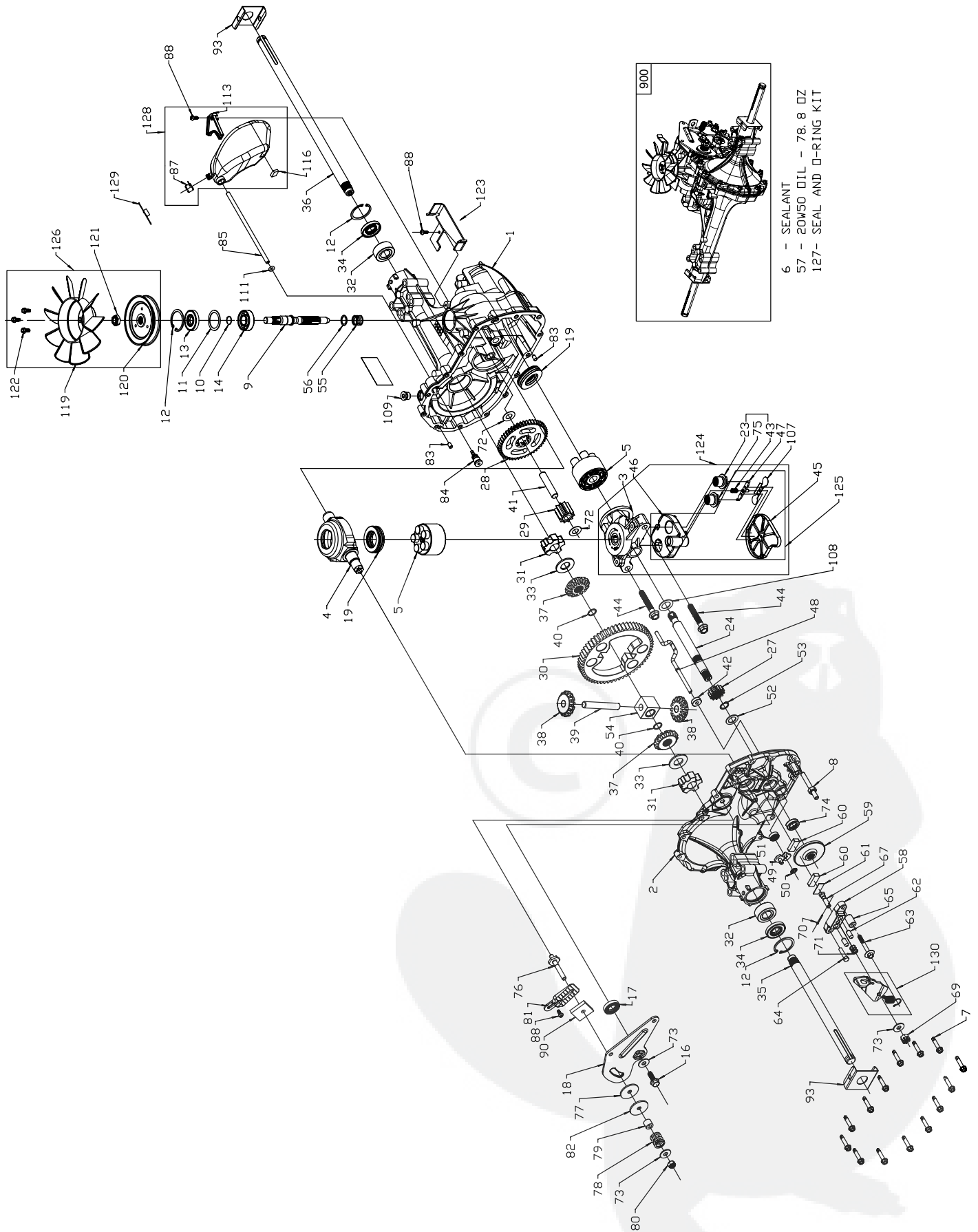

- 6 - SEALANT
- 57 - 20W50 OIL - 78.8 OZ
- 127 - SEAL AND O-RING KIT

# REPAIR PARTS

## TRACTOR- -MODEL NO. 917. 277321

### HYDRO TRANSAXLE - MODEL NUMBER 322-0510

KEY NO.	PART NO.	DESCRIPTION	KEY NO.	PART NO.	DESCRIPTION
1	170351	Kit, Main Housing, Machined Bushing .865 X .985 X .790	67	170413	Bolt, Square Head - Brake
2	170352	Kit, Side Housing, Machined Bushing .865 X .985 X .790	69	170415	Nut, Castle 5/16-24
		Bushing .624 X .719 X .562	70	170416	Pin, Cotter 3/32x3/4
3	170353	Kit, Center Section	71	170417	Brake Spring
		Center Section, Machined	72	170418	Washer (310-0750)
		Bushing .707 X .788 X .591	73	142884	Washer, Flat
4	170354	Swashplate, Trunnion Machined	74	170419	Seal, Oil
5	169898	Kit, Cylinder Block (10cc) Cylinder Piston Spring, Compression Washer - Thrust	75	170420	Ass'y Check Plug
6	178322	Sealant Tube	76	170421	Bolt, Stud 5/16-24
7	170356	Hexflange Screw 1/4-20 X 1.25	77	170422	Puck, Friction
8	170357	Stud, 5/16-24 Hex Double End	78	142969	Spring
9	170358	Shaft, Input	79	142980	Spacer
10	170359	Retaining Ring	80	150778	Nut, Nylon Insert Hex Lock 5/16-24
11	170360	Spacer	81	170423	Wedge, Friction
12	169870	Retaining Ring	82	170424	Clip, Washer
13	170361	Seal, Lip .67 X 1.58 X .276	83	161168	Pin
14	173158	Bearing, Ball 6203 (BDR)	84	170425	Fitting, 5/16 X Sae 5/32 Tube
16	170362	Hex Flange Head Screw 1/4-20 X 1.25	85	170426	Hose, Expansion Tank
17	170363	Seal, Lip 18 X 32 X 7	87	173160	Cap, Vent
18	170364	Arm, Control	88	178334	Bolt, Self Tapping (BDR)
19	173159	Bearing, Thrust (10cc)	90	170430	Puck, Inner Wedge
23	170365	Check Plug Assembly	93	170431	Spring Clip, Housing
24	170366	Shaft Motor	107	170432	Deflector
27	170367	Gear, Pinion, 13t	108	170433	Washer, Motor Shaft .71ID X 1.15OD X .03 Thick
28	170368	10t / 48t Gear	109	170434	Plug, Straight Thread 9/16-18
29	170369	Gear, 10t Jackshaft	111	170435	O-ring .7 X .301 ID
30	170370	60t Bullgear	113	170437	Bracket, Support Expansion Tank
31	170371	Sleeve Bearing .75 X 1.75 X .625	119	173161	Fan (310-3000)
32	170389	Sleeve Bearing (Outboard) .75 X 1.575 X .625	120	170440	Pulley
33	142991	Washer	121	170441	Hex Nut Locking
34	170390	Lip Seal, Axle Shaft	122	173162	Screw, #12-24 Hx Hd Self Tapping (310-3000)
35	170391	Shaft, Axle (Keyed, R.h.)	123	173163	Bracket, Belt Keeper
36	170392	Shaft, Axle (Keyed, L.h.)	124	170444	Kit, Center Section Filter Bypass, Center Section Machining, Base Filter W/ Poppet, Check Plug Assembly, 027 Washer, Check Plug Assembly, Washer Spring, Bypass, Actuator, Bypass Deflector Bottom, Filter Bushing .707 X .788 X .591
37	150792	Gear, Splined Diff. (210-1000 & 310-0750)	125	170445	Kit, Filter, Bottom, Filter Spring, Bypass Actuator, Bypass Deflector
38	150793	Gear, Miter Diff. (210-1000 & 310-0750)			Base, Filter W/ Poppet
39	150809	Differential Shaft (310-0750)	126	173164	Kit, Fan / Pulley, #12 T.f. Screw - Indented Hex Washer Head, Fan
40	170393	Retaining Ring			Pulley 4.315 X .801
41	170394	Pin, Jackshaft	127	170447	Kit, Seal
42	170395	Magnet, Ring			Lip Seal .67 X 1.58 X .276
43	170396	Spring, Bypass			Lip Seal 18 X 32 X 7
44	150797	Bolt 3/8-24 X 2-1/2			Lip Seal .706 X 1.584 X .25
45	170397	Filter			Lip Seal .741 X .250 X .250 TC
46	170398	Base, Filter			Oil Seal 625 X 1.0 X .25
47	170399	Actuator, Bypass			O-ring .07 X .301 ID
48	170400	Rod, Bypass Actuator	128	173165	Kit, Expansion Tank
49	170401	Arm, Bypass			Tank, Expansion
50	170402	Retaining Ring .25 External			Cap, Vent
51	170403	Seal, Lip .741 X .25 X .25			Bolt, Self Tapping 10-32 X 1/2
52	170404	Washer, Flat 0.050" (210-1000)			Bracket, Support Expansion Tank
53	170405	Retaining Ring			Silicon Sponge 1/2 X 1/2 X 3/16
54	170406	Bearing, Center Block	129	191032	Cap, Expansion Tank Shipping
55	142977	Spring, Helical Compression	130	186352	Kit, Brake Arm And Spring
56	142978	Washer, Block Thrust			Arm, Brake
57	-- --	20w-50 Oil 78.8 Oz			Spring, Brake Arm Bias
58	142929	Kit, Brake Yoke			Instruction Sheet
59	170408	Rotor, Brake	900	171613	Transaxle
60	142883	Brake Puck			
61	142882	Brake Puck Plate			
62	170409	Pin, Brake Actuating			
63	170410	HFHCS 1/4-20 X 2 W/patch, Special Flange			
64	142892	Bolt, Nylok			
65	170411	Spacer, Brake Torsion Spring			

**NOTE:** All Component Dimensions Given In U.s. Inches 1 Inch = 25.4 MM

# REPAIR PARTS

TRACTOR- -MODEL NO. 917. 277321

BRIGGS & STRATTON ENGINE - - MODEL NUMBER 282H07, TYPE NUMBER 0239-E1

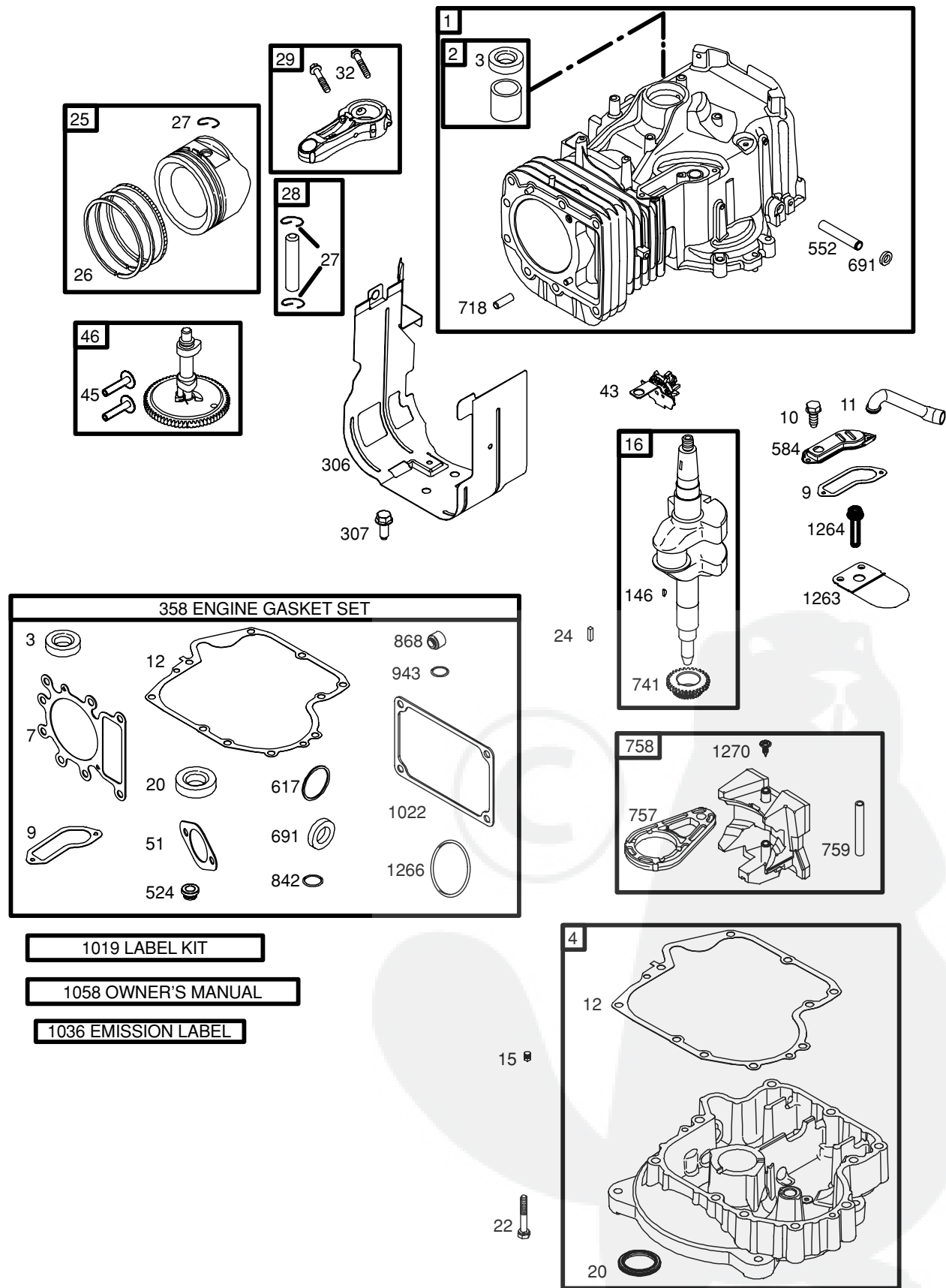

1019 LABEL KIT

1058 OWNER'S MANUAL

1036 EMISSION LABEL

# REPAIR PARTS

TRACTOR- -MODEL NO. 917. 277321

BRIGGS & STRATTON ENGINE - - MODEL NUMBER 282H07, TYPE NUMBER 0239-E1

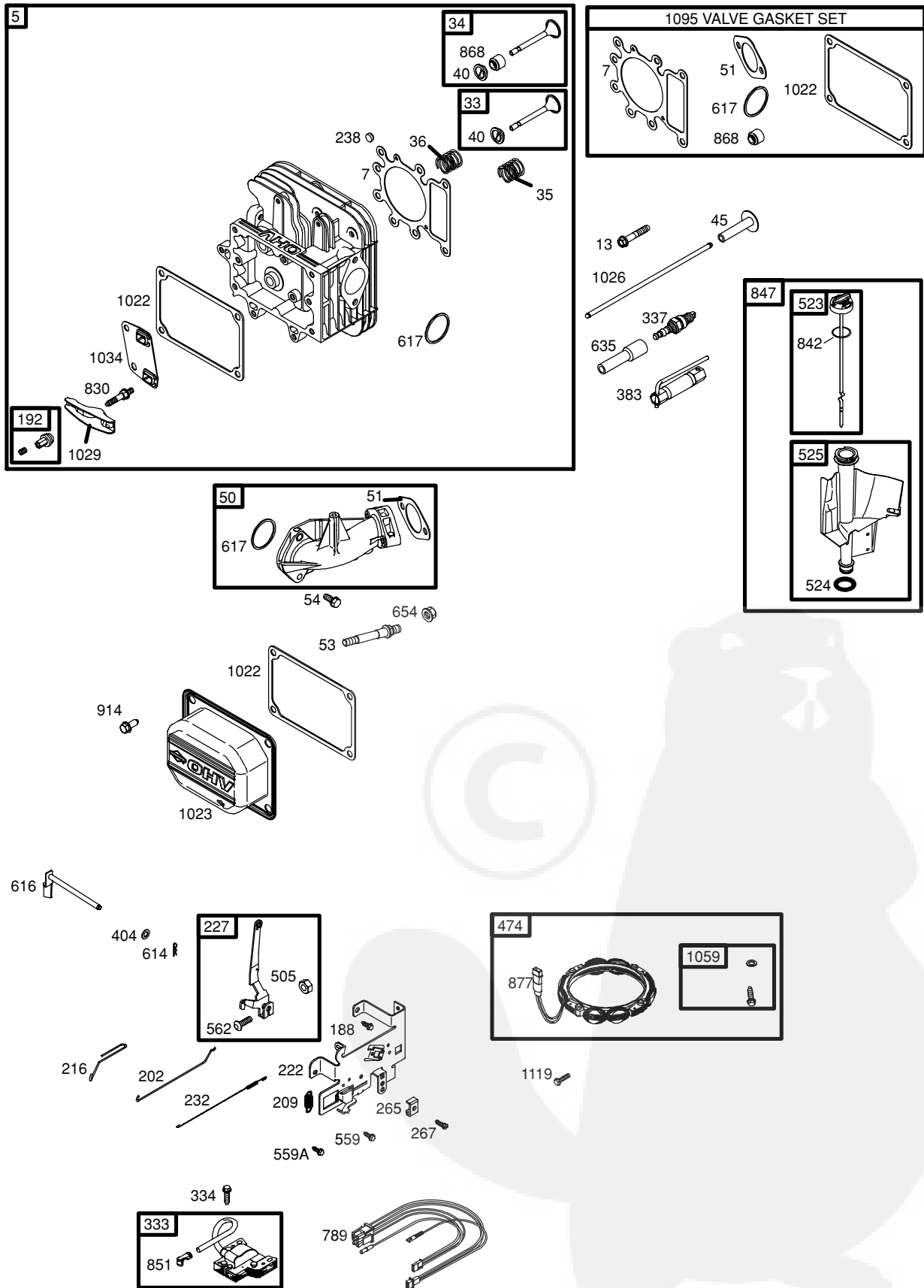

# REPAIR PARTS

TRACTOR- -MODEL NO. 917. 277321

BRIGGS & STRATTON ENGINE - - MODEL NUMBER 282H07, TYPE NUMBER 0239-E1

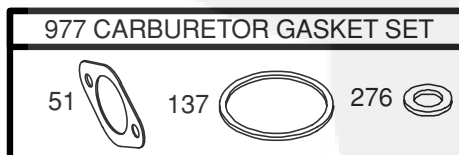
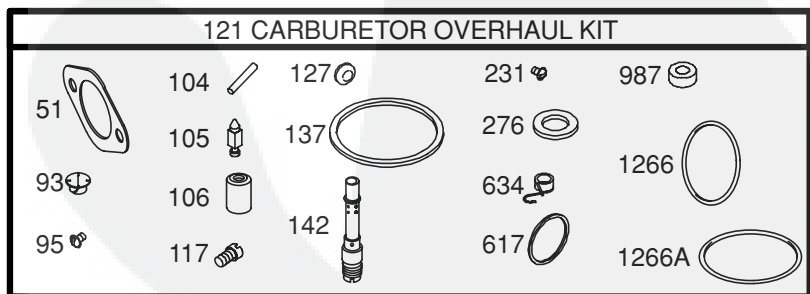
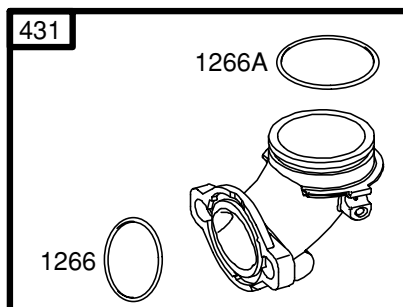
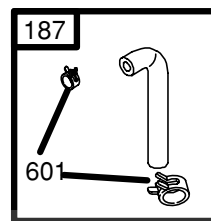
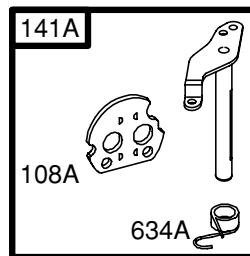
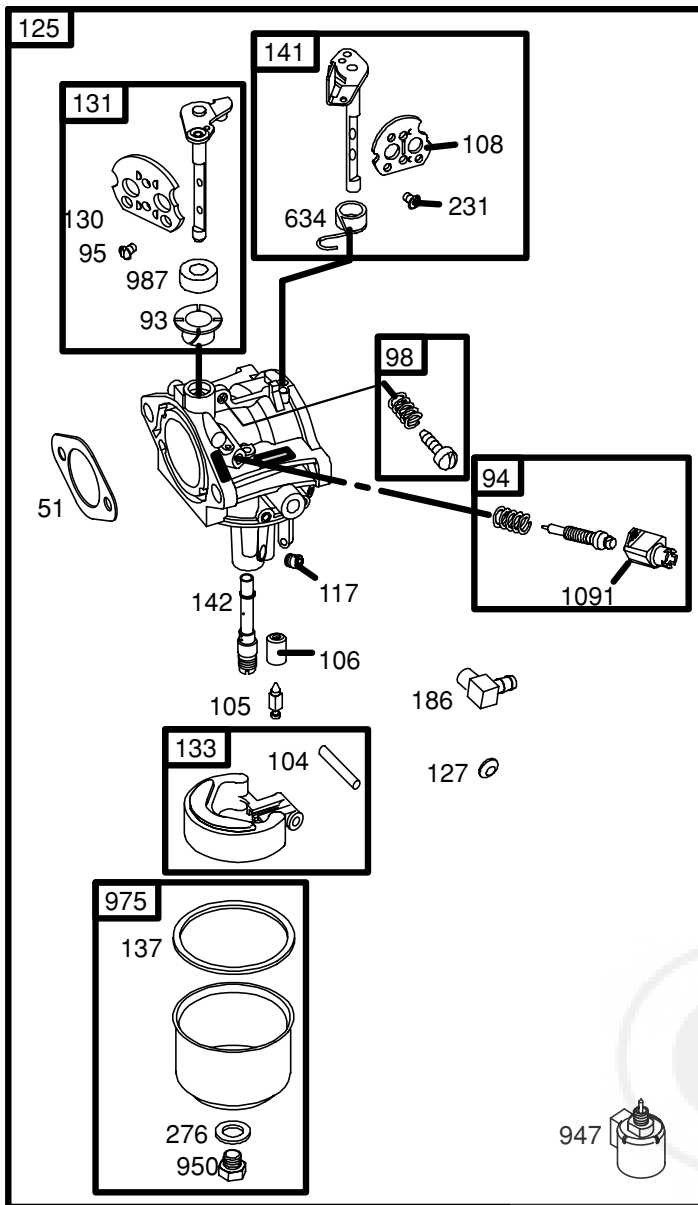



# REPAIR PARTS

TRACTOR- -MODEL NO. 917. 277321

BRIGGS & STRATTON ENGINE - - MODEL NUMBER 282H07, TYPE NUMBER 0239-E1

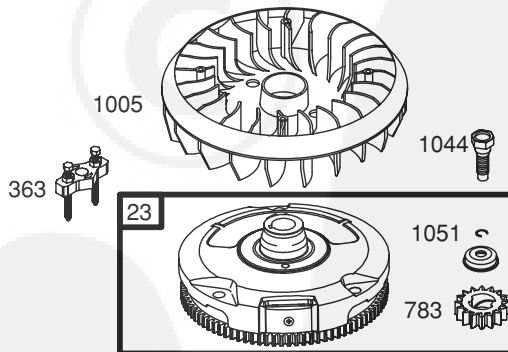
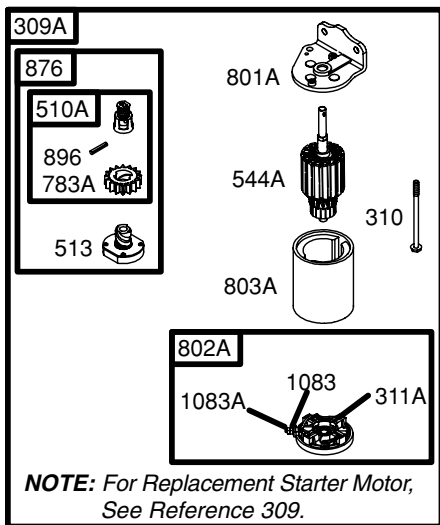
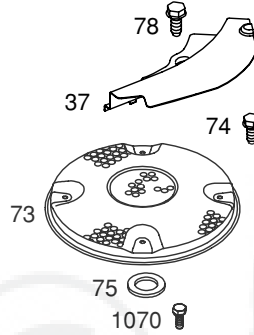
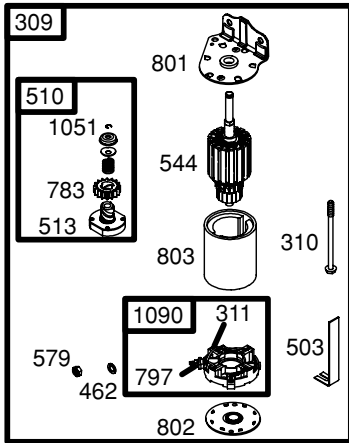
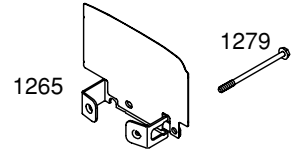
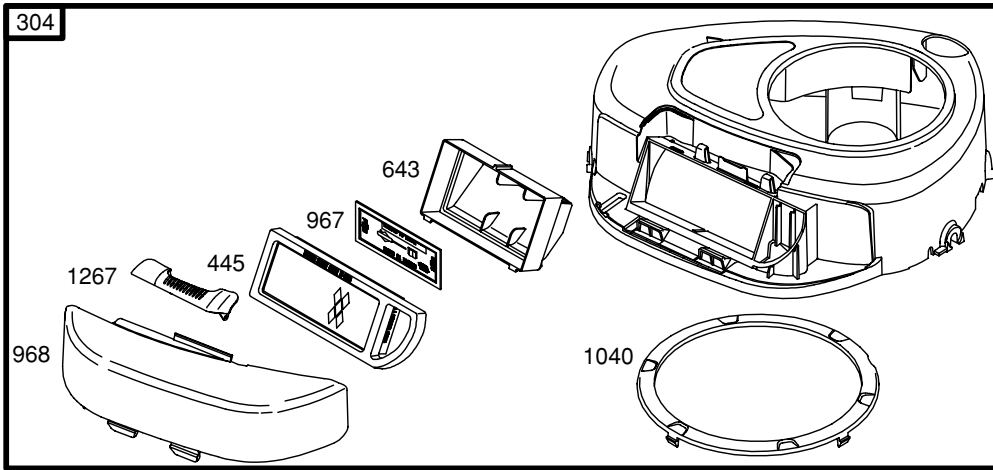
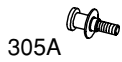

# REPAIR PARTS

## TRACTOR- -MODEL NO. 917. 277321

### BRIGGS & STRATTON ENGINE - - MODEL NUMBER 282H07, TYPE NUMBER 0239-E1

KEY NO.	PART NO.	DESCRIPTION	KEY NO.	PART NO.	DESCRIPTION
1	697132	Cylinder Assembly	108	690464	Valve-Choke (Manual Choke)
2	399265	Kit-Bushing/Seal (Magneto Side)	108A	692344	Valve-Choke (Choke A Matic)
3	391086	• Seal-Oil (Magneto Side)	117	694352	∅ Jet-Main (Standard)
4	697106	Sump-Engine	118	697228	Jet-Main (High Altitude)
5	698148	Head-Cylinder	121	697241	Kit-Carburetor Overhaul
7	273280	•+ Gasket-Cylinder Head	125	697190	Carburetor
9	697109	• Gasket-Breather	127	695005	Plug-Welch
10	697157	Screw (Breather Assembly)	130	691750	Valve-Throttle
11	697113	Tube-Breather	131	494379	Kit-Throttle Shaft
12	697110	• Gasket-Crankcase	133	494381	Float-Carburetor
13	690360	Screw (Cylinder Head)	137	281165	∅‡ Gasket-Float Bowl
15	690946	Plug-Oil Drain	141	495097	Kit-Choke Shaft (Manual Choke)
16	697127	Crankshaft	141A	495931	Kit-Choke Shaft (Choke A Matic)
20	690947	• Seal-Oil (PTO Side)	142	697140	∅ Nozzle-Carburetor
22	692125	Screw (Crankcase Cover/Sump)	146	691639	Key-Timing
23	693557	Flywheel	186	698174	Connector-Hose
24	222698	Key-Flywheel	187	697098	Line-Fuel
25	697114	Piston Assembly (Standard)	188	691693	Screw (Control Bracket)
	697116	Piston Assembly (.010" Oversize)	192	691986	Adjuster-Rocker Arm
	697117	Piston Assembly (.020" Oversize)	202	691841	Link-Mechanical Governor
	697118	Piston Assembly (.030" Oversize)	209	692208	Spring-Governor
26	697115	Ring Set (Standard)	216	691840	Link-Choke
	697119	Ring Set (.010" Oversize)	222	694042	Bracket-Control
	697120	Ring Set (.020" Oversize)	227	691374	Lever-Governor Control
	697121	Ring Set (.030" Oversize)	231	691636	Screw (Choke Valve)
27	698469	Lock-Piston Pin	232	691842	Spring-Governor
28	697099	Pin-Piston	238	691843	Cap-Valve
29	697126	Rod-Connecting (Standard)	240	394358	Filter-Fuel
32	692852	Screw (Connecting Rod)	265	691024	Clamp-Casing
33	495856	Valve-Exhaust	267	695134	Screw (Casing Clamp)
34	495857	Valve-Intake	276	692255	∅‡ Washer-Sealing
35	691279	Spring-Valve (Intake)	304	698402	Housing-Blower
36	691279	Spring-Valve (Exhaust)	305	697102	Screw (Blower Housing)
37	697352	Guard-Flywheel	305A	697103	Screw (Blower Housing)
40	691752	Retainer-Valve	306	697107	Shield-Cylinder
43	691968	Slinger-Governor/Oil	307	691003	Screw (Cylinder Shield)
45	690564	Tappet-Valve	309	693551	Motor-Starter
46	697687	Camshaft	309A	---	Motor-Starter (For Replacement Starter Motor, See Reference 309)
48	697761	Short Block (31C707-0230-E2 Replacement Engine-art not available)	310	690323	Bolt (Starter Motor)
50	690193	Manifold-Intake	311	497608	Brush Set
51	692137	•∅‡+ Gasket-Intake	311A	395538	Brush Set
53	690227	Stud (Carburetor)	333	492341	Armature-Magneto
54	691148	Screw (Intake Manifold)	334	691061	Screw (Magneto Armature)
73	697384	Screen-Rotating	337	691043	Plug-Spark
74	697987	Screw (Rotating Screen)	358	697151	Gasket Set-Engine
75	690582	Washer (Flywheel)	363	19203	Flywheel Puller
78	691003	Screw (Flywheel Guard)	383	89838	Wrench-Spark Plug
93	690602	∅ Bushing-Throttle Shaft			RPM Settings: Low Speed: 1900-2100 High Speed: 3000-3200
94	498030	Kit-Idle Mixture			
95	691636	Screw (Throttle Valve)			
98	495800	Kit-Idle Speed			
104	690525	∅ Pin-Float Hinge			• Included in Engine Gasket Set, Key. No. 358
105	231855	∅ Valve-Float Needle			∅ Included in Carburetor Overhaul Kit, Key. No. 121
106	690577	∅ Seat-Inlet			‡ Included in Carburetor Gasket Set, Key. No. 977
					+ Included in Valve Gasket Set, Key. No. 1095

**NOTE:** All component dimensions given in U.S. inches 1 inch = 25.4 mm

# REPAIR PARTS

## TRACTOR- -MODEL NO. 917. 277321

### BRIGGS & STRATTON ENGINE - - MODEL NUMBER 282H07, TYPE NUMBER 0239-E1

KEY NO.	PART NO.	DESCRIPTION	KEY NO.	PART NO.	DESCRIPTION
404	691691	Washer (Governor Crank)	868	690968	•+ Seal-Valve
431	697122	Elbow-Intake	876	495877	Kit-Pinion Spring
445	698083	Filter-Air Cleaner Cartridge	877	393456	Wire-Connector/Alternator
462	691261	Washer (Starter Cable)	896	691641	Pin-Drive Retainer
474	696459	Alternator	914	690960	Screw (Rocker Cover)
503	691532	Strap-Starter	947	694393	Solenoid-Fuel
505	691251	Nut (Governor Control Lever)	950	691657	Screw (Float Bowl)
510	693699	Drive-Starter	967	697015	Filter-Pre Cleaner
510A	497606	Drive-Starter	968	698403	Cover-Air Cleaner
513	692024	Clutch-Drive	975	495933	Bowl-Float
523	697086	Dipstick	977	690192	Gasket Set-Carburetor
524	691032	• Seal-Dipstick Tube	987	691326	∅ Seal-Throttle Shaft
525	697184	Tube-Dipstick	1005	697853	Fan-Flywheel
544	692034	Starter-Armature	1019	697143	Kit-Label
544A	390837	Starter-Armature	1022	272475	•+ Gasket-Rocker Cover
552	697144	Bushing-Governor Crank	1023	692492	Cover-Rocker Arm
559	697561	Screw (Remote Choke)	1026	692003	Rod-Push (Intake)
559A	693675	Screw (Remote Choke)	-- --	692011	Rod-Push (Exhaust)
562	691119	Bolt (Governor Control Lever)	1029	691751	Arm-Rocker
579	691029	Nut (Starter Cable)	1034	690822	Guide-Push Rod
584	697112	Cover-Breather Passage	1036	695700	Label-Emission
601	95162	Clamp-Hose	1040	698368	Plate-Trim
614	691620	Pin-Cotter	1044	691658	Screw (Flywheel)
616	692012	Crank-Governor	1051	691265	Ring-Retaining
617	692138	∅ • Seal-O Ring (Intake Manifold)	1058	275038	Owner's Manual
634	690801	∅ Spring/Seal Assembly (Manual Choke)	1059	698516	Kit-Screw/Washer
634A	690802	∅ Spring/Seal Assembly (Choke A Matic)	1070	690372	Screw (Flywheel Fan)
635	691909	Boot-Spark Plug	1083	691626	Nut (Starter Terminal)
643	698401	Retainer-Air Filter	1083A	690958	Nut (Starter Terminal)
654	690958	Nut (Carburetor)	1090	691293	Retainer-Brush
691	692407	• Seal-Governor Shaft	1091	691333	Cap-Limiter
697	690372	Screw (Drive Cap)	1095	691581	Gasket Set-Valve
718	690959	Pin-Locating	1119	691183	Screw (Alternator)
729	691224	Clip-Wire	1263	697124	Reed-Breather
741	697128	Gear-Timing	1264	697104	Screw (Breather Reed)
757	697607	Link-Counterweight	1265	697125	Support-Blower Housing
758	697134	Counterweight	1266	691917	•∅ Seal-O Ring (Intake Elbow)
759	697392	Pin-Counterweight	1266A	697123	∅ Seal-O Ring(Intake Elbow)
783	693713	Gear-Pinion	1267	697575	Latch-Blower Housing
783A	693059	Gear-Pinion	1270	697156	Plug-AVS Counterweight
789	698329	Harness-Wiring	1279	690960	Screw (Blower Housing Support)
797	693167	Nut (Brush Retainer)			Low Speed: 1900-2100
801	691283	Cap-Drive			High Speed: 3000-3200
801A	394856	Cap-Drive			
802	691286	Cap-End			
802A	395537	Cap-End			
803	693757	Housing-Starter			
803A	398159	Housing-Starter			
830	691095	Stud (Rocker Arm)			
842	691031	• Seal-O Ring (Dipstick Tube)			
847	697611	Dipstick/Tube Assembly			
851	692424	Terminal-Spark Plug			

- Included in Engine Gasket Set, Key. No. 358
- ∅ Included in Carburetor Overhaul Kit, Key. No. 121
- ‡ Included in Carburetor Gasket Set, Key. No. 977
- + Included in Valve Gasket Set, Key. No. 1095

**NOTE:** All component dimensions given in U.S. inches 1 inch = 25.4 mm

### **LIMITED WARRANTY ON CRAFTSMAN RIDING EQUIPMENT**

For one (1) year from the date of purchase, if this Craftsman Riding Equipment is maintained, lubricated and tuned up according to the instructions in the owner's manual, Sears will repair or replace free of charge any parts that are found to be defective in material or workmanship according to the guidelines of coverage listed below. Sears will also provide free labor for these applicable warranted parts for the full year. During the first 30 days of purchase, there will be no charges to service the product at your home for issues covered by this warranty. (See exclusions below). For your convenience, IN HOME warranty service will still be available after the first 30 days of purchase, but a trip charge will apply. This charge will be waived if the Craftsman product is dropped off at an authorized Sears location. For the nearest authorized Sears location, please call 1-800-4-MY-HOME®. This warranty applies only while this product is within the United States.

This Warranty does not cover:

- Expendable items which become worn during normal use, including but not limited to blades, spark plugs, air cleaners, belts, and oil filters.
- Standard Maintenance Servicing, oil changes, or tune-ups
- Tire replacement or repair caused by punctures from outside objects, such as nails, thorns, stumps, or glass.
- Repairs necessary because of operator abuse, including but not limited to, damage caused by towing objects beyond the capability of the riding equipment, impacting objects that bend the frame or crankshaft, or over-speeding the engine.
- Repairs necessary because of operator negligence, including but not limited to, electrical and mechanical damage caused by improper storage, failure to use the proper grade and amount of engine oil, failure to keep the deck clear of flammable debris, or failure to maintain the equipment according to the instructions contained in the owner's manual.
- Engine (fuel system) cleaning or repairs caused by fuel determined to be contaminated or oxidized (stale). In general, fuel should be used within 30 days of its purchase date.
- Normal deterioration and wear of the exterior finishes, or product label replacement.
- Riding equipment used for commercial or rental purposes.

### **LIMITED WARRANTY ON BATTERY**

For ninety (90) days from date of purchase, if any battery included with this riding equipment proves defective in material or workmanship and our testing determines the battery will not hold a charge, Sears will replace the battery at no charge. During the first 30 days of purchase, there will be no charges to replace the battery at your HOME. After the first 30 days, for your convenience, IN-HOME warranty service will still be available but a trip charge will apply. This charge will be waived if the Craftsman product is dropped off at an authorized Sears location. For the nearest authorized Sears location, please call 1-800-4-MY-HOME®.

This battery warranty applies only while this product is within the United States.

This warranty gives you specific legal rights, and you may also have other rights, which vary, from state to state.

Sears, Roebuck and Co., Dept. 817WA, Hoffman Estates, IL 60179



**CRAFTSMAN®**