

**REPAIR PARTS MANUAL**  
**MODEL NO. 277520**  
**Lawn Tractor**

**CRAFTSMAN®**

197627 2.14.05 RD  
PRINTED IN U.S.A.

# HOW TO USE THIS MANUAL

This manual is designed to provide the customer with a means to identify the parts on his/her tractor when ordering repair parts. The illustrations may or may not represent the actual assemblies; therefore, it is not recommended to use this manual as a guide to assemble or disassemble the tractor. Some hardware and parts are drawn larger in order to more readily identify them.

Each tractor has its own model number.

The model number for your tractor can be found on the fender under the seat.

When ordering parts, always give the following information:

- Product - "Tractor"
- Model Number - "277520"
- Part Number
- Part Description

## TABLE OF CONTENTS

<b>SCHEMATIC .....</b>	<b>3</b>
<b>ELECTRICAL.....</b>	<b>4-5</b>
<b>CHASSIS.....</b>	<b>6-7</b>
<b>DRIVE.....</b>	<b>8-9</b>
<b>STEERING .....</b>	<b>10-11</b>
<b>SEAT .....</b>	<b>12</b>
<b>DECALS.....</b>	<b>13</b>
<b>ENGINE.....</b>	<b>14-15</b>
<b>MOWER LIFT.....</b>	<b>16-17</b>
<b>MOWER DECK .....</b>	<b>18-19</b>
<b>TRANSAXLE.....</b>	<b>20-21</b>
<b>ENGINE BREAKDOWN.....</b>	<b>22-27</b>
<b>WARRANTY.....</b>	<b>28</b>

# TRACTOR- -MODEL NO. 917. 277520

## SCHEMATIC

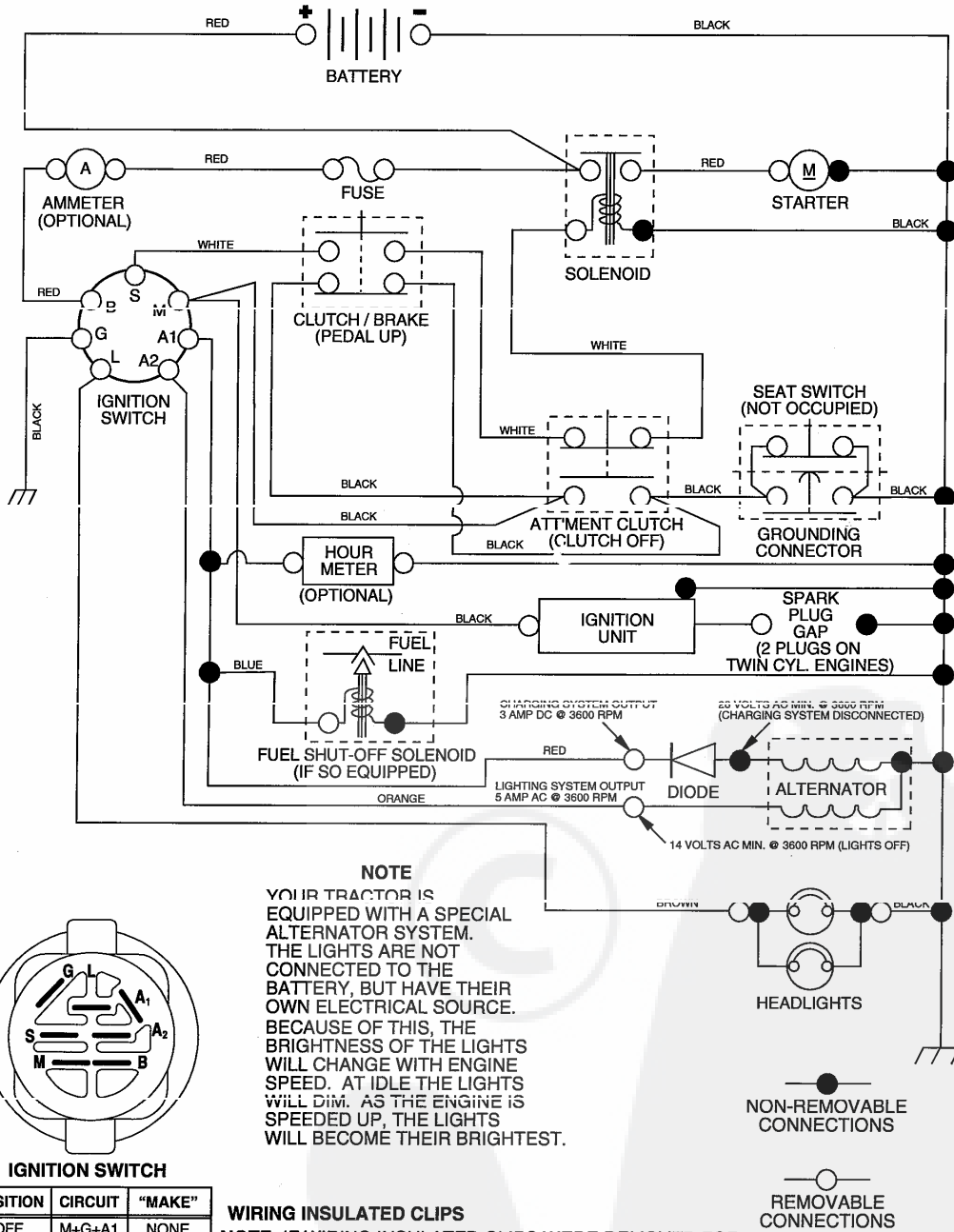

# REPAIR PARTS

TRACTOR- -MODEL NO. 917 277520

## ELECTRICAL

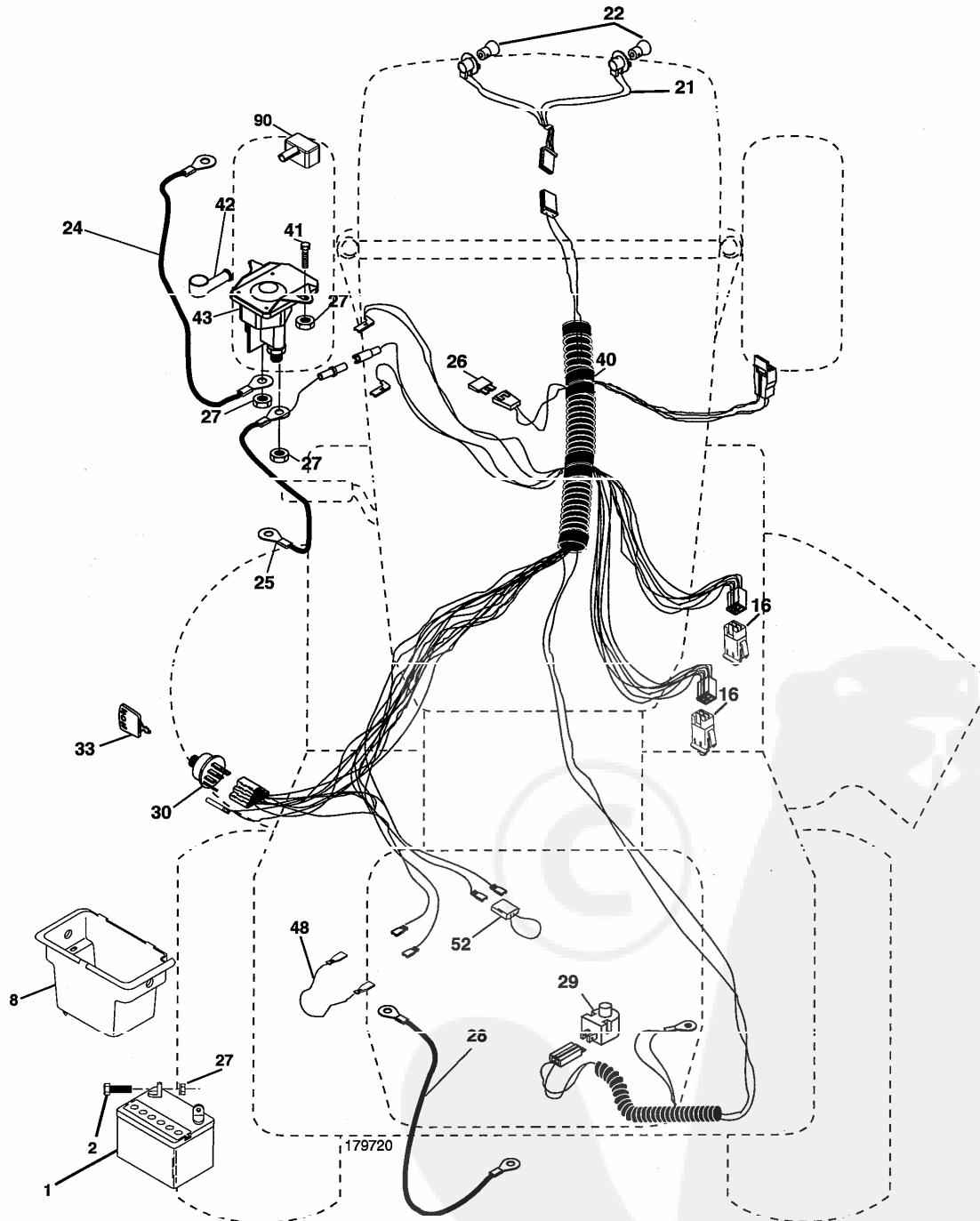

## REPAIR PARTS

TRACTOR- -MODEL NO. 917. 277520

### ELECTRICAL

KEY NO.	PART NO.	DESCRIPTION
1	163465	Battery
2	74760412	Bolt Hex Hd 1/4-20 unc x 3/4
8	176689	Box Battery
16	176138	Switch, Interlock
21	183759	Harness Asm Light W/4152j
22	4152J	Bulb Light #1156
24	4799J	Cable Battery 6 Ga. 11" red
25	146147	Cable Battery
26	175158	Fuse
27	73510400	Nut Keps Hex 1/4-20 Unc
28	4207J	Cable Ground 6 Ga. 12" black
29	121305X	Switch Seat
30	175566	Switch Ign
33	140403	Key Ign
40	179720	Harness Ign
41	71110400	Bolt Dlk. Fin Hex 1/4-20 unc x 1/2
42	131563	Cover Terminal Red
43	192507	Solenoid
48	140844	Adapter Ammeter
52	141940	Protection Wire Loop
90	180449	Cover Terminal

**NOTE:** All component dimensions given in U.S. inches  
1 inch = 25.4 mm

# REPAIR PARTS

TRACTOR- -MODEL NO. 917. 277520

## CHASSIS AND ENCLOSURES

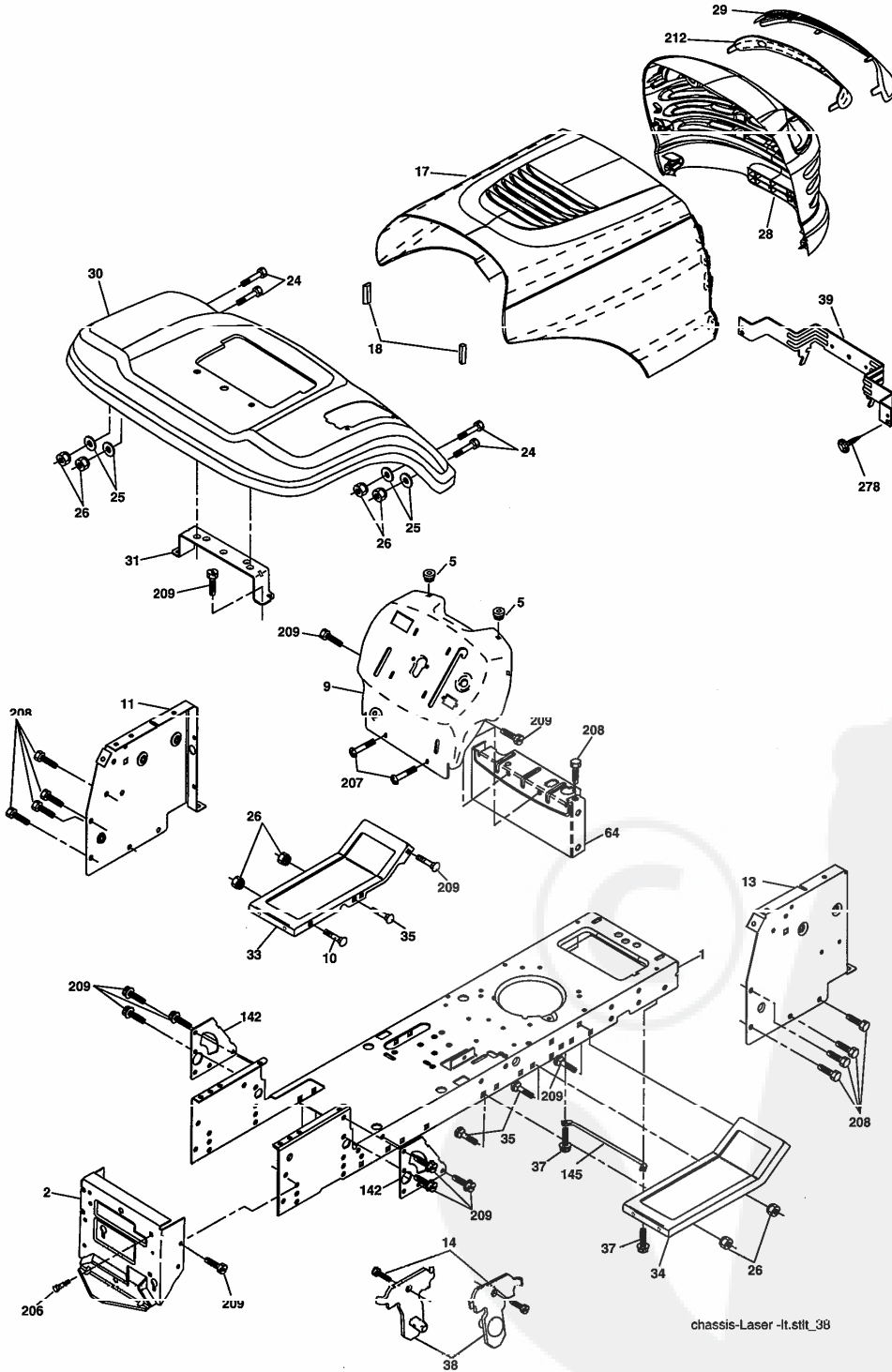

## REPAIR PARTS

TRACTOR- -MODEL NO. 917. 277520

### CHASSIS AND ENCLOSURES

KEY NO.	PART NO.	DESCRIPTION
1	174619	Chassis
2	176554	Drawbar
5	155272	Bumper Hood/Dash
9	193510X013	Dash
10	STD533710	Bolt, Carriage 3/8-16 x 3/4
11	174996	Panel, Dash, L.H.
13	172105X010	Panel, Dash, R.H.
14	17490608	Screw Thdrol 3/8-16 x 1/2
17	185682X613	Hood Assembly
18	184921	Bumper Hood
24	STD523710	Bolt Fin. Hex 3/8-16 x 1
25	19131312	Washer 13/32 x 13/16 x 12 Ga.
26	STD541437	Nut
28	193258	Grille/Lens Asm. (Includes Key Nos. 29 and 212)
29	174332X599	Lens
30	192526X613	Fend/Ftrest
31	136619	Bracket, Fender Support
33	179716X613	Footrest LH
34	179717X613	Footrest RH
35	STD533707	Bolt Rdhd Sht Sqnk 3/8-16 x 3/4
37	17490508	Screw Thdrol 5/16-18 x 1/2
38	175710	Pivot Bracket Assembly, Rear
39	174714	Bracket Pivot Laser Lt
64	154798	Dash Lower STLT
142	175702	Plate Reinforcement STLT
145	156524	Rod Pivot Chassis/Hood
206	170165	Bolt Shoulder 5/16-18 TT
207	17670508	Screw Thdrol 5/16-18 x 1/2 Tytt
208	17670608	Screw Thdrol 3/8-16 x 1/2
209	17000612	Screw Hexwsh Thdr 3/8-16 x 3/4
212	175143	Insert Lens Reflective
278	191611	Screw 10 x 3/4 Single Lead-Hex
--	5479J	Plug, Button
--	195640X426	Plug Switch Light

**NOTE:** All component dimensions given in U.S. inches  
1 inch = 25.4 mm

# REPAIR PARTS

TRACTOR- -MODEL NO. 917. 277520

## DRIVE

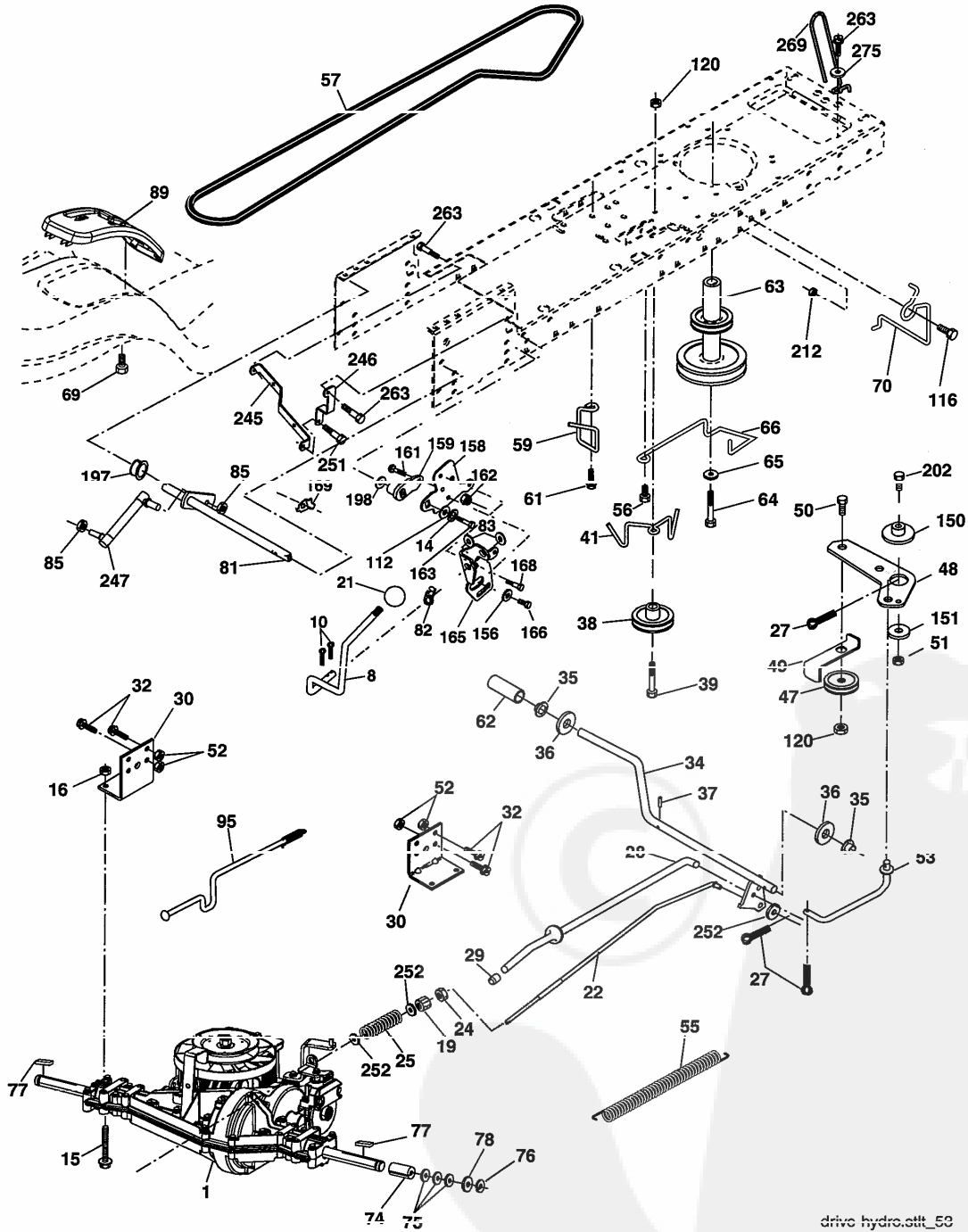

drive hydro.stt\_53



# REPAIR PARTS

## TRACTOR- -MODEL NO. 917. 277520

### DRIVE

KEY NO.	PART NO.	DESCRIPTION	KEY NO.	PART NO.	DESCRIPTION
1	-----	Transaxle Peerless LTH2000 (See Breakdown)	69	142432	Screw Hex Wsh Hi-Lo 1/4-1/2 unc
8	192706	Rod Shift Fender	70	180218	Keeper Belt Engine
10	STD561210	Pin Cotter 1/8 x 1 CAD	74	137057	Spacer
14	10040400	Washer Lock Hvy Helical	75	121749X	Washer 25/32 x 1-1/4 x 16 Ga.
15	74490544	Bolt Hex FLGHD 5/16-18 Gr.5	76	STD581075	E-Ring
16	STD541431	Nut Lock Hex W/Ins. 5/16-18 unc	77	123583X	Key, Square
19	STD541437	Nut Lock Hex W/Wsh 3/8-16 unc	78	121748X	Washer 25/32 x 1-5/8 x 16 Ga.
21	130564	Knob	81	178140	Shaft Asm Cross Tapered
22	178141	Rod, Brake	82	175711	Spring Torsion
24	73350600	Nut. Hex Jam 3/8-16 unc	83	19171216	Washer 17/32 x 3/4 x 16 Ga.
25	106888X	Spring, Brake Rod	85	150360	Nut Lock Center 1/4-28 FNTHD
27	STD561210	Pin Cotter 1/8 x 3/4 CAD.	89	192056X428	Console, Shift
28	175765	Rod, Parking Brake	95	178134	Disconnect Asm Rod Bypass LTH
29	71673	Cap, Parking Brake	112	19091210	Washer 9/32 x 3/4 x 10 Ga.
30	174973	Bracket, Transaxle	116	72140608	Bolt Rdhd Sqneck 3/8-16 x 1
32	74760512	Bolt Hex Hd 5/16-18 unc x 3/4	120	73900600	Nut Lock Flg 3/8-16
34	175578	Shaft, Foot Pedal	150	175456	Spacer Retainer
35	120183X	Bearing, Nylon	151	19133210	Washer 13/32 x 2 x 10 Ga.
36	19211616	Washer	156	166002	Washer Srrtd 5/16 ID x 1.125
37	1572H	Pin, Roll	158	165589	Bracket Shift Mount
38	179114	Pulley, Composite	159	133300	Hub Shift
39	72110622	Bolt Rdhd 3/8-16 unc x 2-3/4 Gr. 5	161	72140406	Bolt Rdhd Sqnk 1/4-20 x 3/4 Gr. 5
41	175556	Keeper, Belt Idler	162	73680400	Nut Crownlock 1/4-20 unc
47	127783	Pulley, Idler, V-Groove	163	74780416	Bolt Hex Fin 1/4-20 unc x 1 Gr. 5
48	154407	Bellcrank, Clutch	165	165623	Bracket Pivot Lever
49	123205X	Retainer, Belt	166	17490510	Screw 5/16-18 x 5/8
50	72110612	Bolt Carr Sh 3/8-16 x 1-1/2 Gr 5	168	165492	Bolt Shoulder 5/16-18 x .561
51	STD541437	Nut Crownlock 3/8-16 unc	169	165580	Plate Fastening
52	STD541431	Nut, Crownlock 5/16-18 unc	197	169613	Nyliner Snap-In 5/8"ID
53	105710X	Link, Clutch	202	72110614	Bolt Carr Sh 3/8-16 x 1-3/4 Gr.5
55	105709X	Spring, Return, Clutch	207	169593	Washer Nyl
56	17060620	Screw 3/8-16 x 1-1/4	212	145212	Nut Hex Flange Lock
57	178138	V-Belt	245	178122	Strap Torque Lh LTH2000
59	169691	Keeper, Center Span	246	178121	Strap Torque Rh LTH2000
61	17120614	Screw 3/8-16 x .875	247	181463	Link Shift Transaxle LTH2000
62	8883R	Cover, Pedal	251	17060516	Screw 5/16-18 x 1
63	180219	Pulley, Engine	252	19131616	Washer 13/32 x 1 x 16 Ga.
64	173937	Bolt Hex 7/16-20 x 4 Gr. 5	263	17000612	Screw Hex Wsh Thdr 3/8-16 x 3/4
65	STD551143	Washer	269	162402	Guard Idler
66	154778	Keeper Belt Engine Hydro	275	19131614	Washer 13/32 x 1 x 14 Ga.

**NOTE:** All component dimensions given in U.S. inches  
1 inch = 25.4 mm

# REPAIR PARTS

TRACTOR- -MODEL NO. 917 277520

## STEERING ASSEMBLY

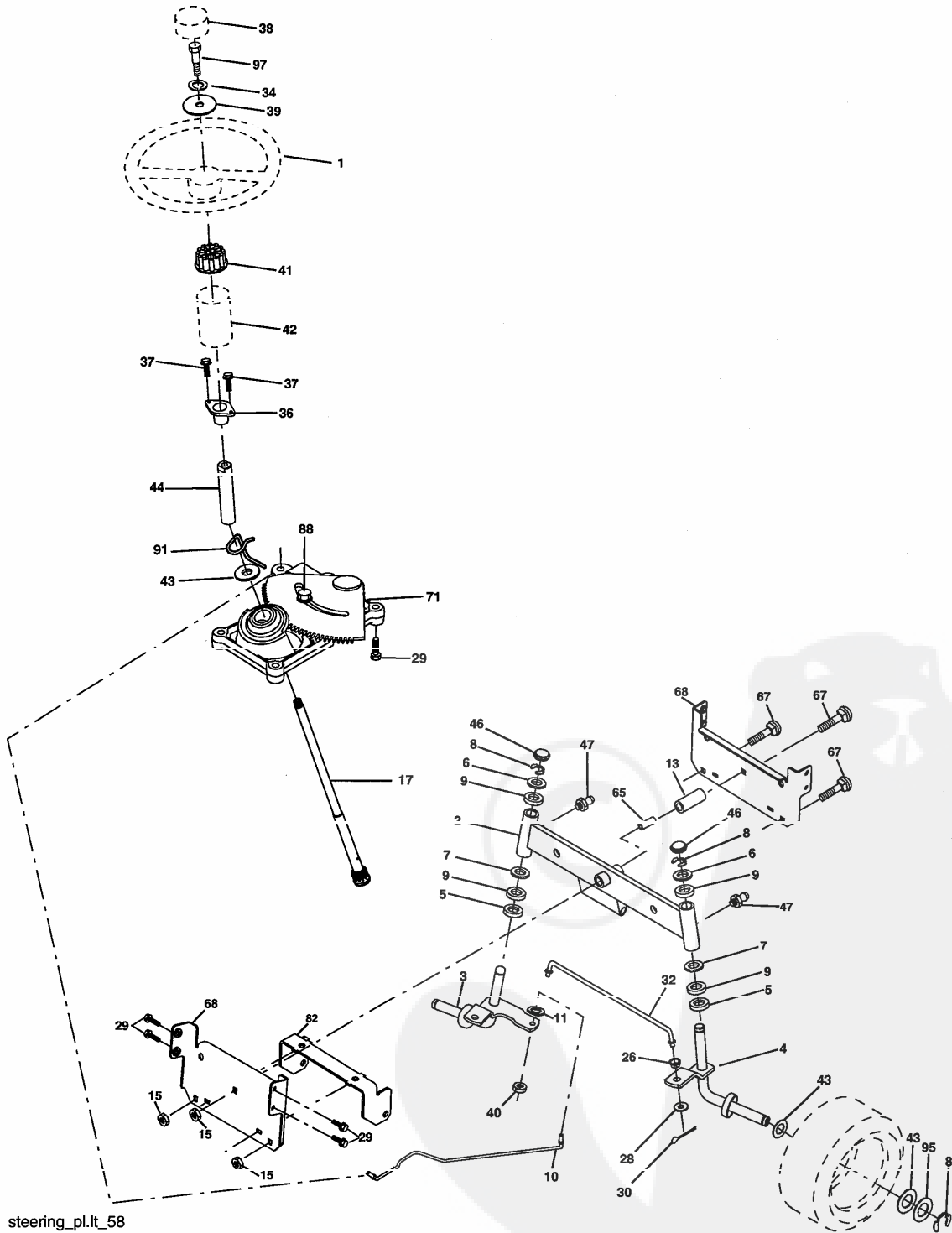

steering\_pl.lt\_58

## REPAIR PARTS

TRACTOR- -MODEL NO. 917. 277520

### STEERING ASSEMBLY

KEY NO.	PART NO.	DESCRIPTION
1	186780	Steering Wheel
2	175131	Axle Assembly
3	169840	Spindle Assembly, L.H.
4	169839	Spindle Assembly, R.H.
5	6266H	Washer Thrust
6	121748X	Washer 25/32 x 1-5/8 x 16 Ga.
7	19272016	Washer 27/32 x 1-1/4 x 16 Ga.
8	12000029	Ring, Klip
9	3366R	Washer Thrust
10	175121	Draglink
11	STD551137	Washer, Lock
13	136518	Spacer Bearing Axle Front
15	145212	Nut, Hex Flange Lock
17	190753	Shaft, Steering
26	126847X	Bushing, Link, Drag
28	19131416	Washer 13/32 x 7/8 x 16 Ga.
29	17000612	Screw 3/8-16 x 3/4
30	STD561210	Pin Cotter
32	192757	Rod, Tie
34	10040500	Washer Lock Hvy. Hicl Spr 5/16
36	155099	Bushing, Steering
37	152927	Screw
38	186781	Insert, Steering Wheel
39	19113812	Washer 11/32 x 2-3/8 12 Ga.
40	STD541537	Nut Lock Center 3/8-24 UNF
41	186737	Adaptor, Steering Wheel
42	145054X428	Boot, Steering Shaft
43	121749X	Washer 25/32 x 1-1/4 x 16 Ga.
44	190752	Extension Shaft Steering
46	121232X	Cap, Spindle
47	183226	Fitting Grease
65	160367	Spacer Brace Axle
67	72110618	Bolt RDHD Sqnk 3/8-16 x 2-1/4
69	169927	Axle, Bracc
71	175146	Steering Asm.
82	169835	Bracket Susp. Chassis Front
88	175118	Bolt Shoulder 7/16-20 unc
91	175553	Clip Steering
95	188967	Washer Hardened
97	74780564	Bolt 5/16-18 unc x 4 Gr. 5

**NOTE:** All component dimensions given in U.S. inches  
1 inch = 25.4 mm

# REPAIR PARTS

TRACTOR- -MODEL NO. 917. 277520

## SEAT ASSEMBLY

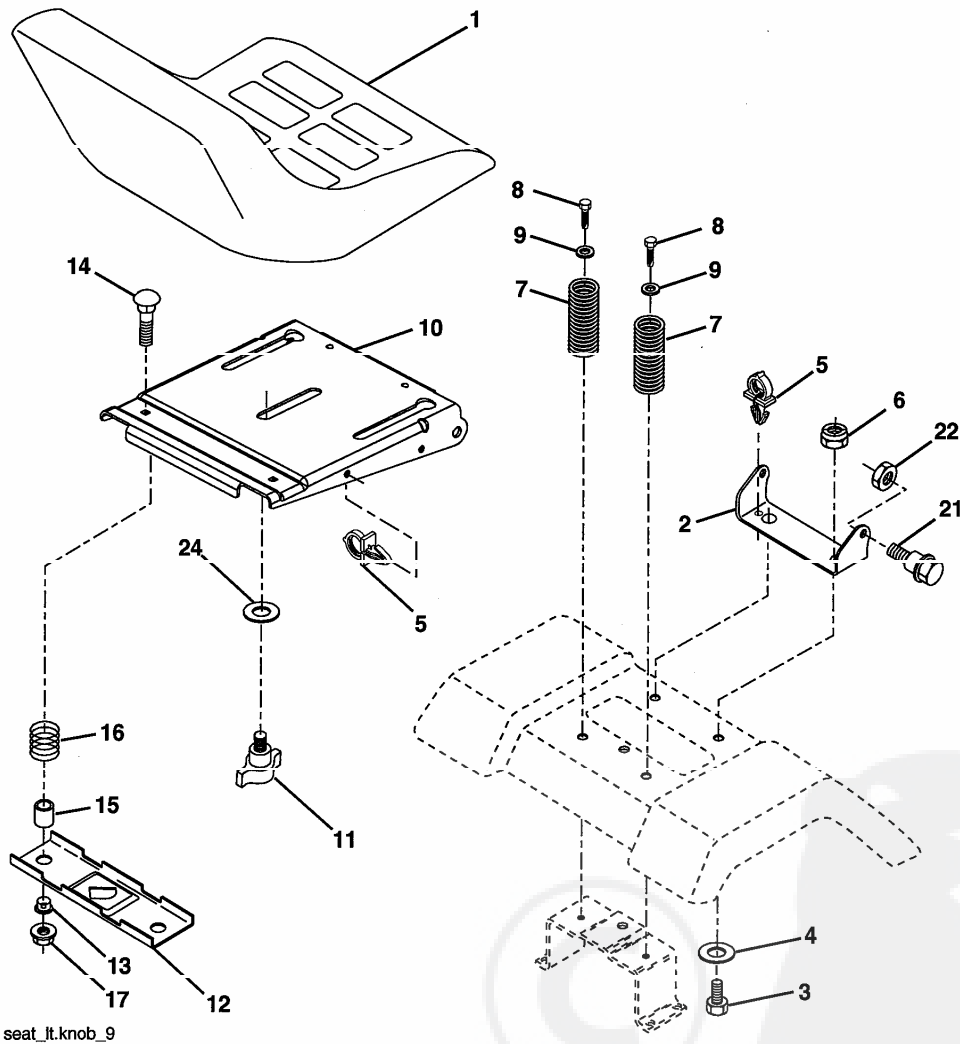

seat\_lt.knob\_9

KEY NO.	PART NO.	DESCRIPTION
1	188716	Seat
2	180166	Bracket Pnt Pivot Seat (blk )
3	71110616	Bolt Fin Hex 3/8-16 unc x 1
4	19131610	Washer 13/32 x 3/4 x 10 Ga.
5	145006	Clip Push In Hinged
6	STD541437	Nut Hex Lock w/Ins 3/8-16 unc
7	124181X	Spring Seat Cprsn 2 250 Blk Zi
8	17000616	Screw 3/8-16 x 1
9	19131614	Washer 13/32 x 1 x 14 Ga.
10	180186	Pan Pnt Seat (blk )
11	166369	Knob Seat Adj Wingnut

KEY NO.	PART NO.	DESCRIPTION
12	121246X	Bracket Pnt Mounting Switch
13	121248X	Bushing Snap Blk Nyl 50 Id
14	72050412	Bolt Rdhd Sht Nk 1/4-20 x 1-1/2
15	134300	Spacer Split 28 x 96 Zinc
16	121250X	Spring Cprsn 1 27 Blk Pnt
17	123976X	Nut Lock 1/4 Lge Flg Gr. 5 Zinc
21	171852	Bolt Shoulder 5/16-18 unc-2A
22	STD541431	Nut Hex Lock w/Ins 5/16-18
24	19171912	Washer 17/32 x 1-3/16 x 12 Ga.

**NOTE:** All component dimensions given in U.S. inches  
1 inch = 25.4 mm

# REPAIR PARTS

## TRACTOR- -MODEL NO. 917. 277520

### DECALS

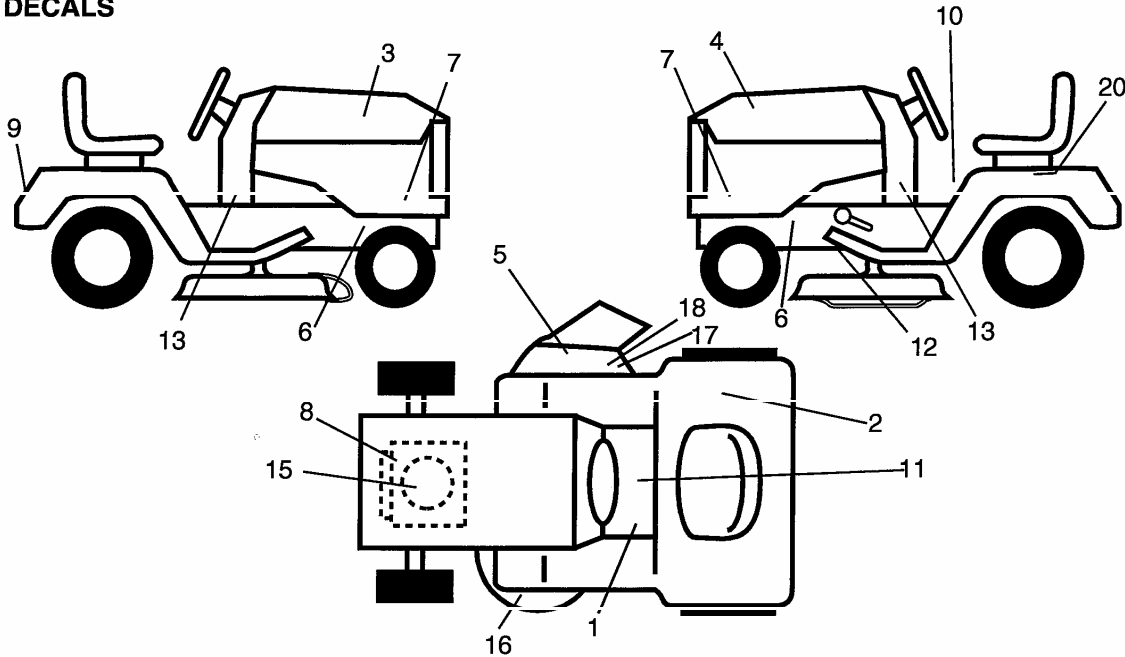

KEY NO.	PART NO.	DESCRIPTION
1	159737	Decal, Brake/Clutch Sym
2	180432	Decal, Fender DB/CE
3	186280	Decal, Hood, R.H.
4	186281	Decal, Hood, L.H.
5	179128	Decal, Deck "B" 42"
6	159736	Decal, Hot Muffler
7	193545	Decal, Hood Side
8	196841	Decal, Warning Eng. Sym
9	186282	Decal, Fender, Craftsman
10	140837	Decal, Saddle Brake Parking
11	145498	Decal, Read Owners Manual
12	197490	Decal, V-Belt Drive Schematic
13	166767	Decal, Dash Panel

KEY NO.	PART NO.	DESCRIPTION
15	186377	Decal, Engine
16	160396	Decal, V-Belt Schematic
17	196357	Decal, Def. Warn Sym
18	182166	Decal, Cuffinger
20	145005	Decal, Battery Dngr/Psn Eng
--	138311	Decal, Lift Handle
--	178392	Decal, Disconnect
--	179768X428	Pad, Footrest LH STLT
--	179769X428	Pad, Footrest RH STLT
--	197625	Manual, Operator's Euro
--	197626	Manual, Operator's Scan
--	197627	Manual, Parts

### WHEELS & TIRES

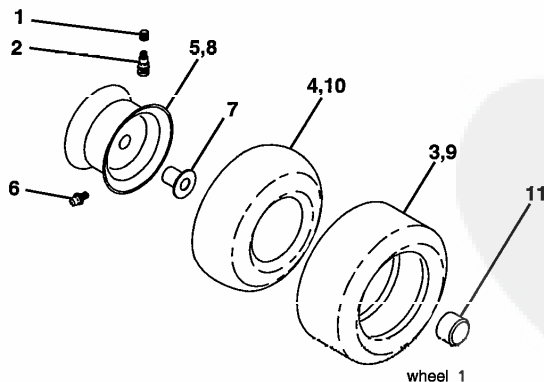

KEY NO.	PART NO.	DESCRIPTION
1	59192	Cap Value Tire
2	65139	Stem Valve
3	106222X	Tire F Ts 15 x 6.0 - 6 Service
4	59904	Tube Inner Front #35060
5	106732X624	Rim Asm 6" front White Service
6	278H	Fitting Grease
7	9040H	Bearing Flange
8	106108X624	Rim Asm 8" rear White Service
9	106268X	Tire R Ts 18 x 9 5-8 Service
10	7152J	Tube Rear 9.5 x 8 Service
11	104757X428	Cap Axle Blk 1.50 x 1.00
--	144334	Sealant, Tire (10 oz. tube)

NOTE: All component dimensions given in U.S. inches  
1 inch = 25.4 mm

# REPAIR PARTS

TRACTOR- -MODEL NO. 917. 277520

## ENGINE

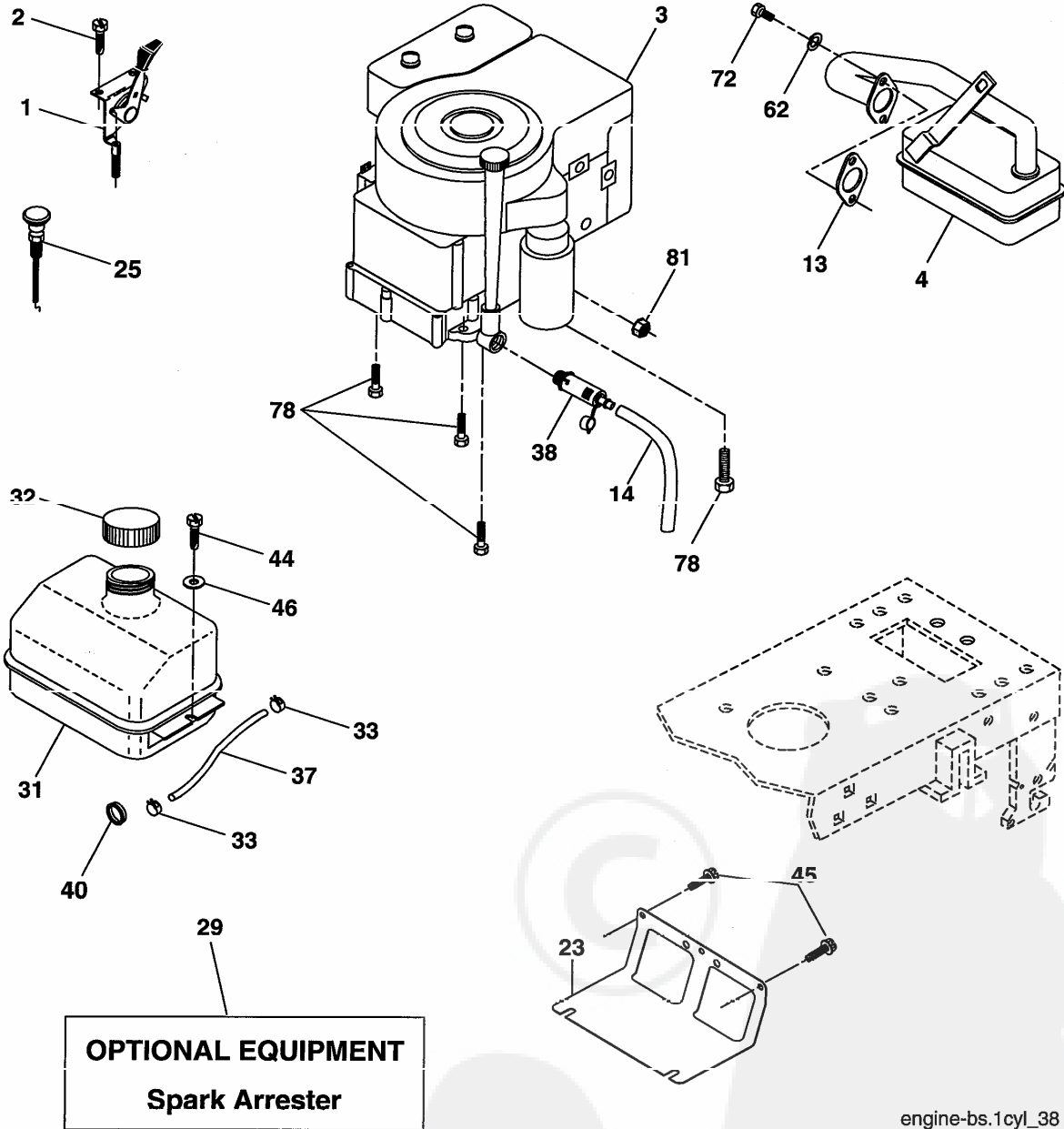

engine-bs.1cyl\_38

## REPAIR PARTS

TRACTOR- -MODEL NO. 917. 277520

### ENGINE

KEY NO.	PART NO.	DESCRIPTION
1	170545	Control, Throttle/Choke
2	17720408	Screw, Hex Head, Thread Cutting 1/4-20 x 1/2
3	-----	Engine, Briggs Model 31C707-0240-E1 (See Breakdown)
4	137352	Muffler
13	165291	Gasket
14	148456	Tube Drain Oil Easy
23	169937	Shield Dnn/Dbr Guard
25	187770X428	Control Choke
29	137180	Arrestor, Spark
31	187750	Tank, Fuel
32	140527	Cap Assembly, Fuel Sears, Vented
33	123487X	Clamp, Hose
37	137040	Line, Fuel
38	181654	Plug Drain Oil Easy
40	124028X	Bushing, Snap, Fuel Line
44	17070412	Screw, Hex Washer Head, Tilt., Fuel. 1/4-20 x 3/4
45	17000612	Screw Hxwsh Thdr 3/8-16 x 3/4
46	19091416	Washer 9/32 x 7/8 x 16 Ga.
62	10010500	Washer Split

**NOTE:** All component dimensions given in U.S. inches  
1 inch = 25.4 mm

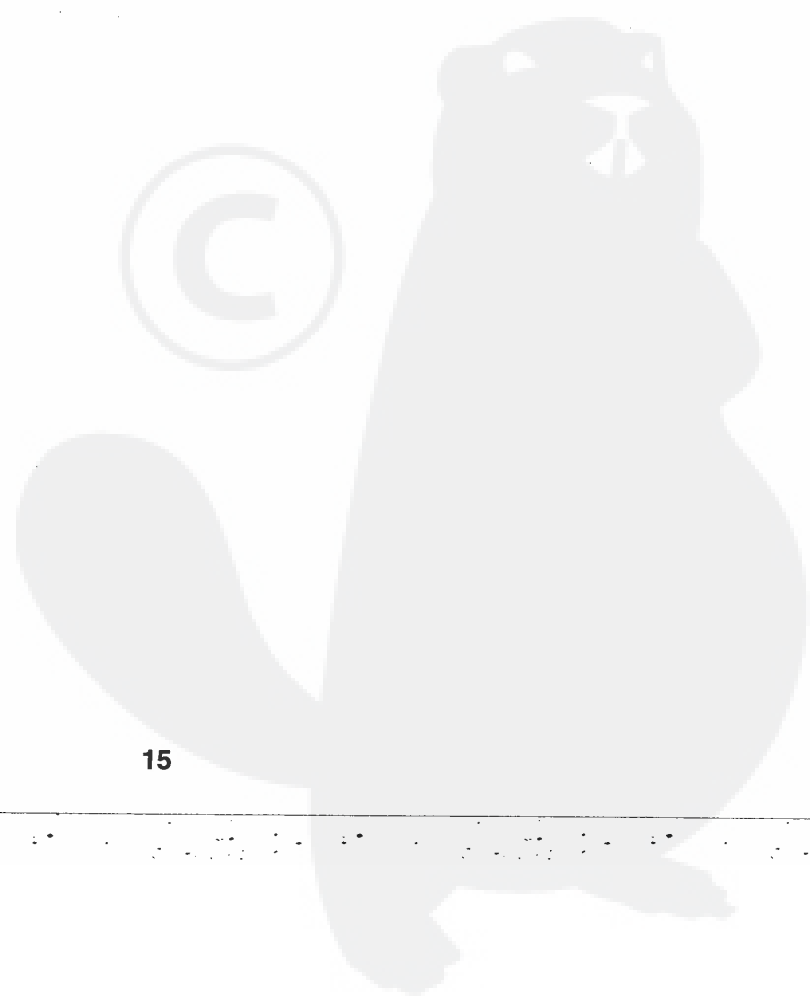
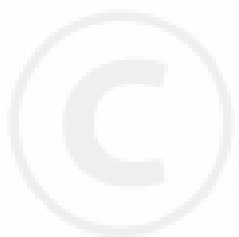

# REPAIR PARTS

TRACTOR- -MODEL NO. 917. 277520

## MOWER LIFT

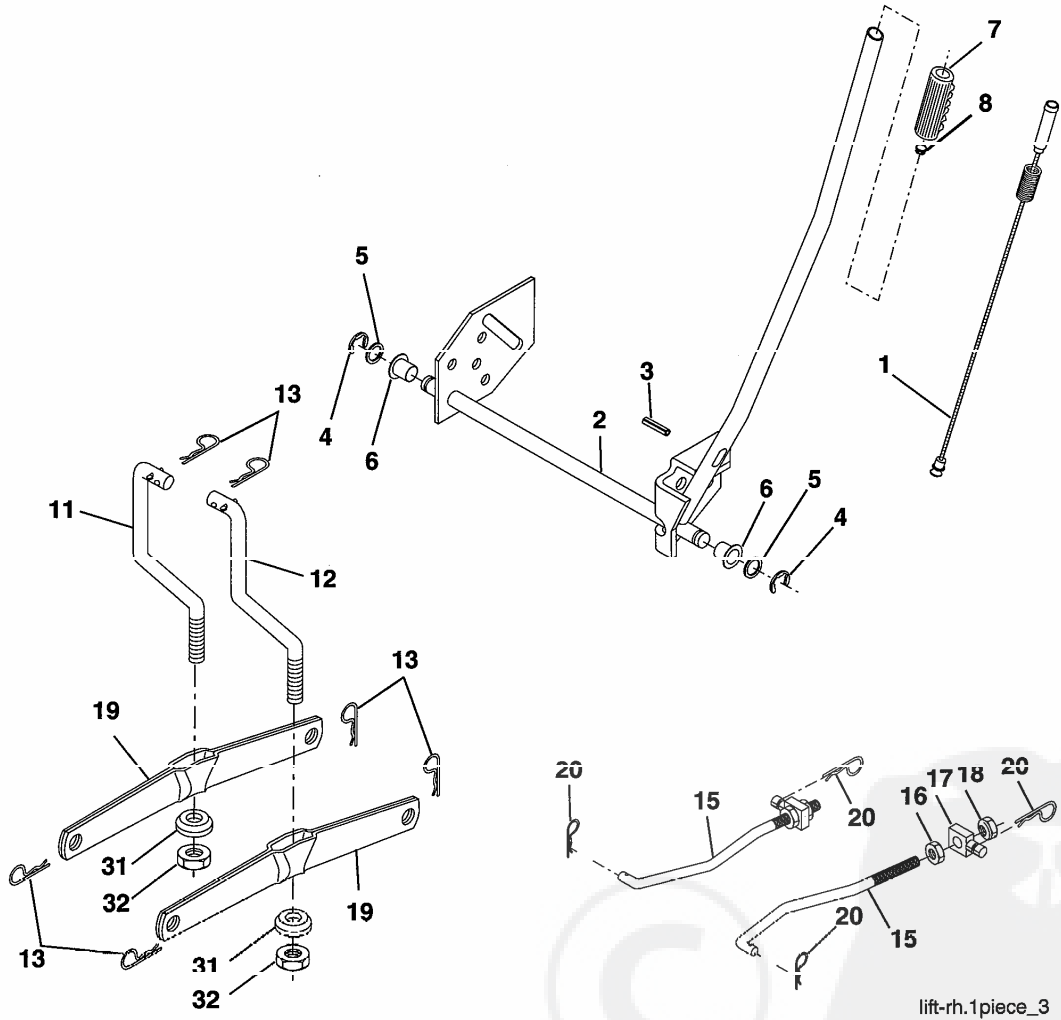

lift-rh.1piece\_3



## REPAIR PARTS

TRACTOR- -MODEL NO. 917. 277520

### MOWER LIFT

KEY NO.	PART NO.	DESCRIPTION
1	159460	Washer Asm Inner Spring W/ Plunger
2	159471	Shaft Asm. Lift
3	105767X	Pin Groove
4	12000002	E Ring #5133-62
5	19211621	Washer 21/32 x 1 x 21 Ga.
6	120183X	Bearing Nylon
7	125631X	Grip Handle Fluted
8	122365X	Button Plunger Read
11	139865	Link Asm Lift L.H.
12	139866	Link Asm Lift R.H.
13	STD624008	Retainer Spring
15	173288	Link Front
16	73350800	Nut Jam Hex 1/2-13 unc
17	175689	Trunnion Blk Zinc
18	73800800	Nut Lock w/Wsh 1/2-13 unc
19	139868	Arm Suspension Mower
20	163552	Retainer Spring
31	169865	Bearing, Pvt. Lift
32	73540600	Nut Crownlock 3/8-24

**NOTE:** All component dimensions given in U.S. inches  
1 inch = 25.4 mm

# REPAIR PARTS

TRACTOR- -MODEL NO. 917. 277520

MOWER

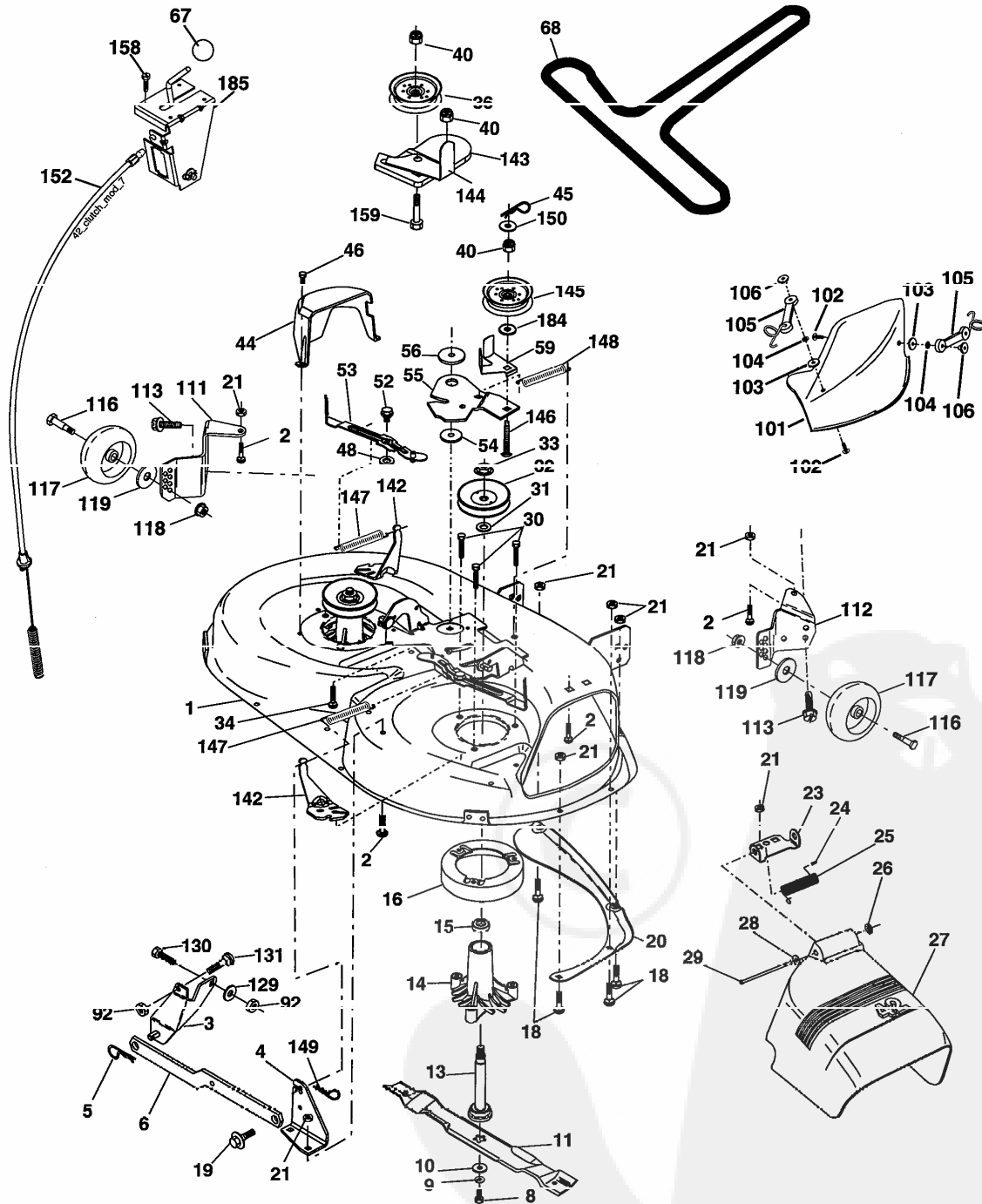

42\_D\_man-t-path\_stlt\_3

# REPAIR PARTS

## TRACTOR- -MODEL NO. 917. 277520

### MOWER

KEY NO.	PART NO.	DESCRIPTION	KEY NO.	PART NO.	DESCRIPTION
1	165892	Mower Deck Assembly, 42"	55	155046	Arm, Idler
2	STD533107	Bolt	56	165723	Spacer, Retainer
3	136017	Bracket Assembly, Sway Bar, Front	59	141043	Guard, TUV idler
4	165460	Bracket Sway Bar 38/42" Deck	67	149846	Knob Custom Oval
5	STD624008	Retainer Spring	68	180215	V-Belt
6	178024	Bar Sway Deck	101	136420	Cover Mulching
8	850857	Blade, Hex 3/8-24 x 1.25 Gr. 8	102	71081010	Screw Pan Head Phillips 10-24 x 5/8
9	STD551137	Washer, Lock	103	19061216	Washer #10
10	140296	Washer, Hardened (The following blades are available)	104	10071000	Washer Lock #8
11	134149	Blade, 42" Mulching Std (For mulching mowers only)	105	160793	Latch Asm
--	138971	Blade, 42" Hi-Lift (For bagging or discharging)	106	2029J	Nut Weld
13	137645	Shaft Assembly, Mandrel, Vented	111	179292	Bracket Wheel Gauge LH
14	128774	Housing, Mandrel, Vented	112	179293	Bracket Wheel Gauge RH
15	110485X	Bearing, Ball, Mandrel	113	17000510	Bolt 5/16-18 Hex Whs. Hd
16	174493	Stripper, Vented Mower Deck	116	4898H	Bolt Shoulder
18	72140505	Bolt, Carriage 5/16-18 x 5/8	117	188606	Wheel Gauge
19	132827	Bolt, Shoulder	118	73930600	Nut Center lock 3/8-16 UNC
20	159770	Baffle, Vortex	119	1912414	Washer 3/8 x 7/8 x 14 Ga.
21	STD541431	Nut Crownlock 5/16-18 unc	142	165890	Arm Spring Brake Mower
23	177563	Bracket, Deflector	143	157109	Bracket Arm Idler 42"
24	105304X	Cap, Sleeve	144	158634	Keeper Belt 42" Clutch Cable
25	123713X	Spring, Torsion, Deflector	145	165888	Pulley Idler Flat
26	110452X	Nut, Push	146	171977	Bolt Carriage Idler
27	130968X428	Shield, Deflector	147	179748	Spring Extension
28	19111016	Washer 11/32 x 5/8 x 16 Ga.	148	169022	Spring Return Idler
29	131491	Rod, Hinge	149	165898	Retainer Spring Yellow Zinc
30	173984	Screw Thdrol Washer Head	150	19091210	Washer 9/32 x 3/4 x 10 Ga.
31	187690	Washer, Spacer	152	181555	Cable Clutch 42 In
32	153535	Pulley, Mandrel	158	17720408	Screw Hex Thd Cut 1/4-20 x 1/2
33	178342	Nut, Toplock, Flanged	159	72140614	Bolt Rdhd Sqn 3/8-16 unc x 3/4
34	72110612	Bolt Carr. Sh. 3/8-16 x 1-1/2 Gr. 5	184	19131410	Washer 13/13 x 7/8 x 10 Ga.
36	131494	Pulley, Idler, Flat	185	188234	Head Asm Cable Clutch
40	73900600	Nut Lock 3/8-16 unc	--	130794	Mandrel Assembly (Includes Housing, Shaft and Shaft Hardware Only - Pulley Not Included)
44	140088	Guard, Mandrel, I H	--	181281	Replacement Mower, Complete
45	STD624003	Retainer			
46	137729	Screw, Thd. Roll 1/4-20 x 5/8			
48	133944	Washer, Hardened			
52	139888	Bolt, Shoulder 5/16-18 unc			
53	184907	Arm Assembly, Pad, Brake			
54	178515	Washer, Hardened			

**NOTE:** All component dimensions given in U.S. inches  
1 inch = 25.4 mm

# REPAIR PARTS

TRACTOR- -MODEL NO. 917. 277520

PEERLESS TRANSAXLE - MODEL NUMBER LTH2000

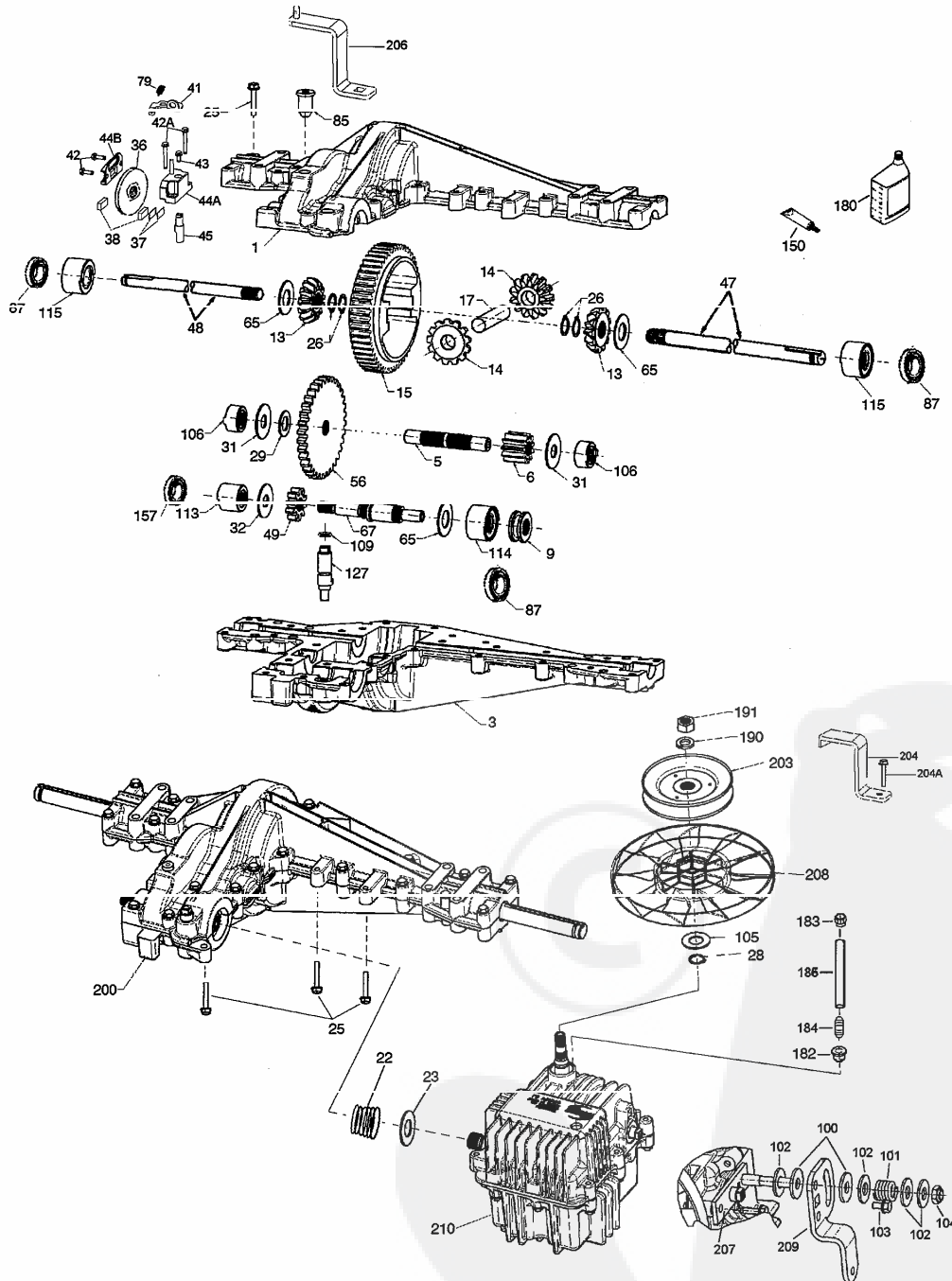

# REPAIR PARTS

TRACTOR- -MODEL NO. 917. 277520

PEERLESS TRANSAXLE - MODEL NUMBER LTH2000

KEY NO.	PART NO.	DESCRIPTION	KEY NO.	PART NO.	DESCRIPTION
1	772151	Cover L.H.	70	786196	Spacer .625 .765
3	773135	Case	79	792201	Spring
5	776355	Counter Shaft	85	792154	Oil Fill Plug
6	778263	Spur Gear 11T	87	788088A	Oil Seal 3/4"
9	786197	Neutral Sleeve (.572)	99	792141	Washer .377ID .058W
13	778368	Bevel Gear (Incl. 14) (13 Teeth)	100	792200	Snubber Washer
14	778368	Bevel Gear (Incl. 13) (13 Teeth)	101	792199	Snubber Spring .47ID
15	778373	Ring Gear (54 Teeth)	102	792184	Washer .437ID .078W
17	786139	Drive Pin	103	792193	Screw, 1/4-28 x .490
22	792194	Spring	104	792198	Nut, 3/8-24
23	792195	Washer .750 ID	105	780096	Washer .625 ID .057W
25	792073A	Screw 1/4-20 x 1-1/4"	106	796162	Sleeve Assembly
26	792125	Retaining Ring	107	792046	Screw, 1/4-20 x 1"
28	792035	Retaining Ring	109	788104	"O" Ring
29	780065	Washer .627 ID .091W	113	786199	Sleeve Ass'y (Incl. 157)
31	780189	Washer .563 ID .062W	114	786200	Sleeve Ass'y (Incl. 87)
36	790071	Brake Disk	115	786198	Sleeve Assembly (Incl. 87)
37	790007	Brake Pad Plate	127	784384	Shift Lever Ass'y (Incl. 109)
38	799021	Brake Pad	150	788093A	Liquid Gasket RTV Silicon
40	792204	Roll Pin .25	157	788102	Oil Seal 9/16"ID
41	790102	Brake Lever	180	730229	BOil Spec. (80W90)
42	792202	Screw, 1/4-20 x 3/4	182	766103	Grinner
42A	792203	Screw, 1/4-20 x 1-3/4	183	792118	Relief Valve
43	792171	Screw, 10-24 x .500	184	792196	Hose Barb
44A	790100	Inside Brake (Mach)	185	798050	Tubing 1/2 x 5
44B	790099	Outside Brake (Casting)	190	792150	Washer
45	790101	Actuator Rod	191	792151	Nut 7/16-20
47	774869	Axle 16.812	200	794787	Differential (Gear Reduction Drive)
48	774688	Axle 11.625	203	798044	Pulley & Hub Ass'y
49	778378	Spur Gear 18T	206	798055	Disconnect Lever
56	778379	Spur Gear 81T	207	798053	Mounting Plate
65	780195	Washer .750ID .062W	208	798040	Fan
67	776440	Brakeshaft	209	798054	Control Lever
			210	794788	Hydro Module LH Fender Control

# REPAIR PARTS

TRACTOR- -MODEL NO. 917. 277520

BRIGGS & STRATTON ENGINE - - MODEL NUMBER 31C707, TYPE NUMBER 0240-E1

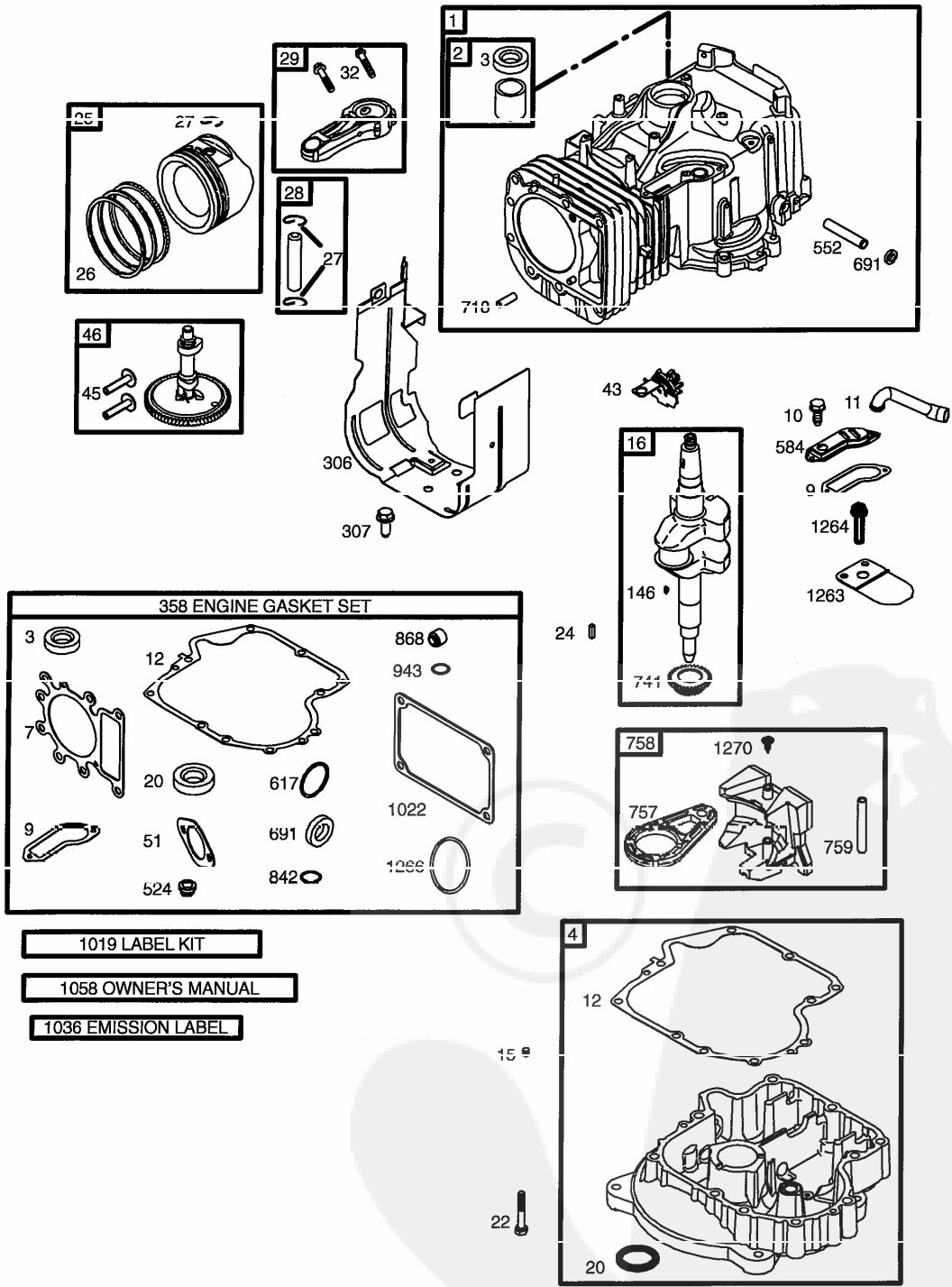

1019 LABEL KIT

1058 OWNER'S MANUAL

1036 EMISSION LABEL

# REPAIR PARTS

TRACTOR- -MODEL NO. 917. 277520

BRIGGS & STRATTON ENGINE - - MODEL NUMBER 31C707, TYPE NUMBER 0240-E1

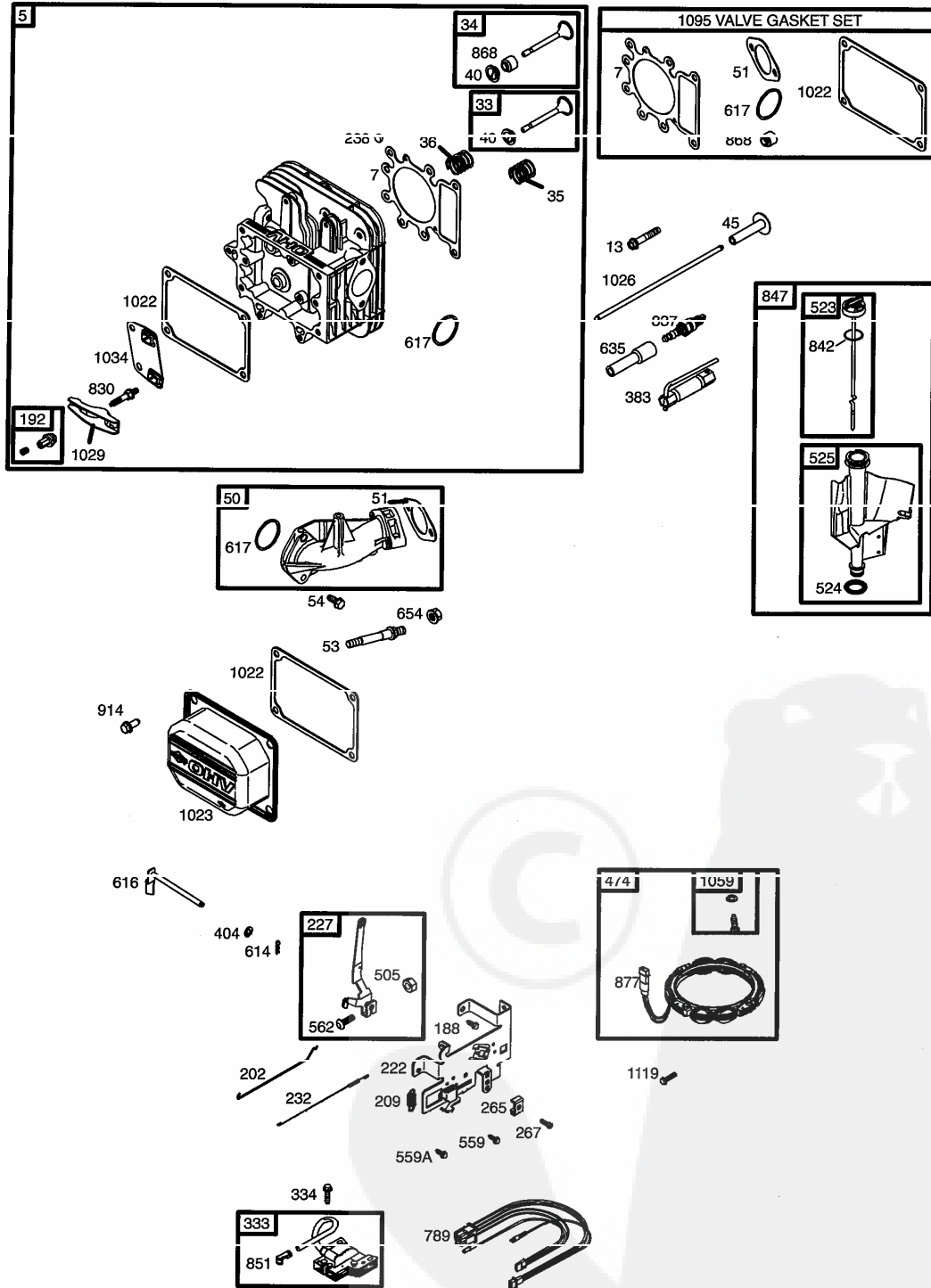

# REPAIR PARTS

TRACTOR- -MODEL NO. 917. 277520

BRIGGS & STRATTON ENGINE - - MODEL NUMBER 31C707, TYPE NUMBER 0240-E1

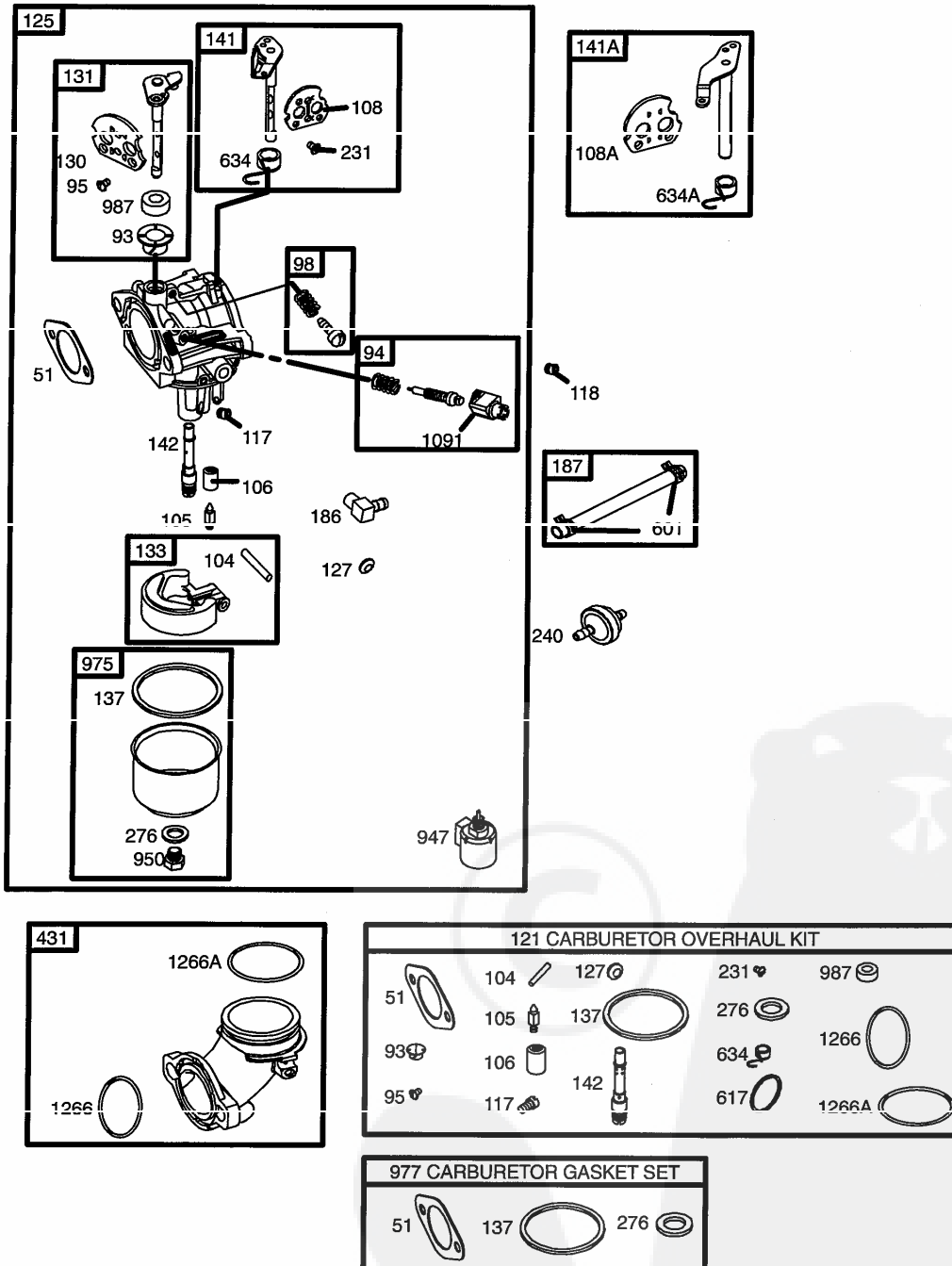



# REPAIR PARTS

TRACTOR- -MODEL NO. 917. 277520  
 BRIGGS & STRATTON ENGINE - - MODEL NUMBER 31C707, TYPE NUMBER 0240-E1

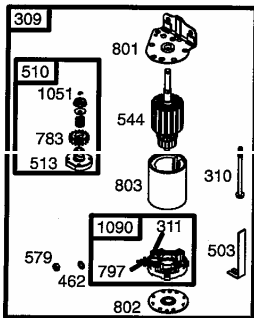
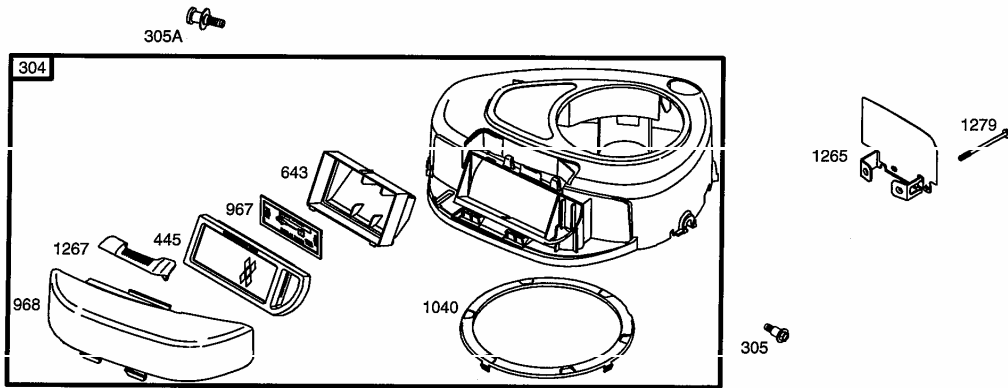

729 697

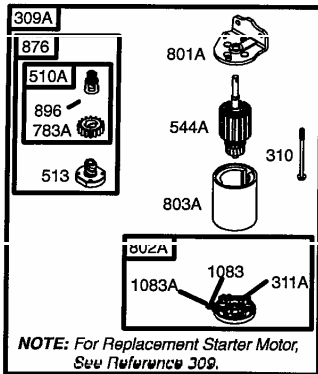
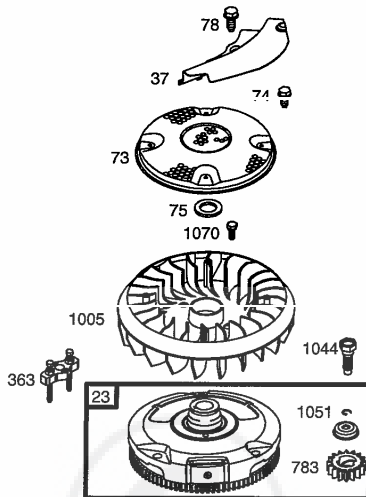

# REPAIR PARTS

## TRACTOR- -MODEL NO. 917. 277520

### BRIGGS & STRATTON ENGINE - - MODEL NUMBER 31C707, TYPE NUMBER 0240-E1

KEY NO.	PART NO.	DESCRIPTION	KEY NO.	PART NO.	DESCRIPTION
1	697174	Cylinder Assembly	118	697492	Jet-Main (High Altitude)
2	399265	Kit-Bushing/Seal (Magneto Side)	121	697241	Kit-Carburetor Overhaul
3	391086	• Seal-Oil (Magneto Side)	125	697190	Carburetor
4	697106	Sump-Engine	127	695005	Flywheel
5	698147	Head-Cylinder	130	691750	Valve-Throttle
7	692410	*+ Gasket-Cylinder Head	131	494379	Kit-Throttle Shaft
9	697109	• Gasket-Breather	133	494381	Float-Carburetor
10	697157	Screw (Breather Assembly)	137	281165	Ø± Gasket-Float Bowl
11	697113	Tube-Breather	141	495097	Kit-Choke Shaft (Manual Choke)
12	697110	• Gasket-Crankcase	141A	495931	Kit-Choke Shaft (Choke A Matic)
13	690360	Screw (Cylinder Head)	142	697140	Ø Nozzle-Carburetor
15	690946	Plug-Oil Drain	146	691639	Key-Timing
16	697127	Crankshaft	186	692317	Connector-Hose
20	690947	• Seal-Oil (P/U Side)	187	691050	Line-Fuel (Cut to Required Length)
22	692125	Screw (Crankcase Cover/Sump)	188	691693	Screw (Control Bracket)
23	693557	Flywheel	192	691986	Adjuster-Rocker Arm
24	222698	Key-Flywheel	202	691841	Link-Mechanical Governor
25	697159	Piston Assembly (Standard)	209	692208	Spring-Governor
	697160	Piston Assembly (.010" Oversize)	222	694042	Bracket-Control
	697162	Piston Assembly (.020" Oversize)	227	691374	Lever-Governor Control
	697163	Piston Assembly (.030" Oversize)	231	691636	Screw (Choke Valve)
26	697164	Ring Set (Standard)	232	691842	Spring-Governor
	697165	Ring Set (.010" Oversize)	238	691843	Cap-Valve
	697171	Ring Set (.020" Oversize)	240	394358	Filter-Fuel
	697172	Ring Set (.030" Oversize)	265	691024	Clamp-Casing
27	697100	Lock-Piston Pin	267	695134	Screw (Casing Clamp)
28	697099	Pin-Piston	276	692255	Ø± Washer-Sealing
29	697126	Rod-Connecting (Standard)	304	698402	Housing-Blower
32	692852	Screw (Connecting Rod)	305	697102	Screw (Blower Housing)
33	495856	Valve-Exhaust	305A	697103	Screw (Blower Housing)
34	495857	Valve-Intake	306	697107	Shield-Cylinder
35	691279	Spring-Valve (Intake)	307	691003	Screw (Cylinder Shield)
36	691279	Spring-Valve (Exhaust)	309	693551	Motor-Starter
37	697352	Guard-Flywheel	309A	-----	Motor-Starter (For Replacement Starter Motor, See Reference 309)
40	691752	Retainer-Valve	310	690323	Bolt (Starter Motor)
43	691968	Slinger-Governor/Oil	311	497608	Brush Set
45	690564	Tappet-Valve	311A	395538	Brush Set
46	697687	Camshaft	333	492341	Armature-Magneto
48	697761	Short Block (31C707-0240-E2 Replacement Engine-art not available)	334	691061	Screw (Magneto Armature)
50	690193	Manifold-Intake	337	691043	Plug-Spark
51	692137	•Ø±+ Gasket-Intake	358	697191	Gasket Set-Engine
53	690227	Stud (Carburetor)	363	19203	Flywheel Puller
54	691148	Screw (Intake Manifold)	383	89838	Wrench-Spark Plug
73	697384	Screen-Rotating	404	691691	Washer (Governor Crank)
74	697987	Screw (Rotating Screen)	431	697122	Elbow-Intake
75	690582	Washer (Flywheel)			
78	691003	Screw (Flywheel Guard)			
93	690602	Ø Bushing-Throttle Shaft			
94	498030	Kit-Idle Mixture			
95	691636	Screw (Throttle Valve)			
98	495800	Kit-Idle Speed			
104	690525	Ø Pin Float Hinge			
105	231855	Ø Valve-Float Needle			
106	690577	Ø Seat-Inlet			
108	690464	Valve-Choke (Manual Choke)			
108A	692344	Valve-Choke (Choke A Matic)			
117	694352	Ø Jet-Main (Standard)			

RPM Settings: Low Speed: 1900-2100  
High Speed: 3000-3200

- Included in Engine Gasket Set, Key. No. 358
- Ø Included in Carburetor Overhaul Kit, Key. No. 121
- ± Included in Carburetor Gasket Set, Key. No. 977
- + Included in Valve Gasket Set, Key. No. 1095

NOTE: All component dimensions given in U.S. inches 1 inch = 25.4 mm



#### **LIMITED WARRANTY ON CRAFTSMAN RIDING EQUIPMENT**

For two (2) years from the date of purchase, if this Craftsman Riding Equipment is maintained, lubricated and tuned up according to the instructions in the owner's manual, Sears will repair or replace free of charge any parts that are found to be defective in material or workmanship according to the guidelines of coverage listed below. Sears will also provide free labor for these applicable warranted parts for the two full years. During the first 30 days of purchase, there will be no charges to service the product at your home for issues covered by this warranty. (See exclusions below). For your convenience, IN HOME warranty service will still be available after the first 30 days of purchase, but a trip charge will apply. This charge will be waived if the Craftsman product is dropped off at an authorized Sears location. For the nearest authorized Sears location, please call 1-800-4-MY-HOME®. This warranty applies only while this product is within the United States.

#### **This Warranty does not cover:**

- Expendable items which become worn during normal use, including but not limited to blades, spark plugs, air cleaners, belts, and oil filters.
- Standard Maintenance Servicing, oil changes, or tune-ups
- Tire replacement or repair caused by punctures from outside objects, such as nails, thorns, stumps, or glass.
- Repairs necessary because of operator abuse, including but not limited to, damage caused by towing objects beyond the capability of the riding equipment, impacting objects that bend the frame or crankshaft, or over-speeding the engine.
- Repairs necessary because of operator negligence, including but not limited to, electrical and mechanical damage caused by improper storage, failure to use the proper grade and amount of engine oil, failure to keep the deck clear of flammable debris, or failure to maintain the equipment according to the instructions contained in the owner's manual.
- Engine (fuel system) cleaning or repairs caused by fuel determined to be contaminated or oxidized (stale). In general, fuel should be used within 30 days of its purchase date.
- Normal deterioration and wear of the exterior finishes, or product label replacement.
- Riding equipment used for commercial or rental purposes.

#### **LIMITED WARRANTY ON BATTERY**

For ninety (90) days from date of purchase, if any battery included with this riding equipment proves defective in material or workmanship and our testing determines the battery will not hold a charge, Sears will replace the battery at no charge. During the first 30 days of purchase, there will be no charges to replace the battery at your HOME. After the first 30 days, for your convenience, IN-HOME warranty service will still be available but a trip charge will apply. This charge will be waived if the Craftsman product is dropped off at an authorized Sears location. For the nearest authorized Sears location, please call 1-800-4-MY-HOME®.

This battery warranty applies only while this product is within the United States.

This warranty gives you specific legal rights, and you may also have other rights, which vary, from state to state.

Sears, Roebuck and Co., Dept. 817WA, Hoffman Estates, IL 60179



**CRAFTSMAN®**