

REPAIR PARTS MANUAL
MODEL NO. BM115T92RB (96061002901)
Lawn Tractor

BESTGREEN

532 19 70-90 01.24.05 TR
PRINTED IN U.S.A.

HOW TO USE THIS MANUAL

This manual is designed to provide the customer with a means to identify the parts on his/her tractor when ordering repair parts. The illustrations may or may not represent the actual assemblies; therefore, it is not recommended to use this manual as a guide to assemble or disassemble the tractor. Some hardware and parts are drawn larger in order to more readily identify them.

Each tractor has its own model number.

The model number for your tractor can be found on the fender under the seat.

When ordering parts, always give the following information:

- Product - "Tractor"
- Model Number - "BM115T92RB (96061002901)"
- Part Number
- Part Description

TABLE OF CONTENTS

SCHEMATIC	3
ELECTRICAL.....	4-5
CHASSIS.....	6-7
DRIVE.....	8-9
STEERING	10-11
SEAT	12
DECALS.....	13
ENGINE.....	14
MOWER LIFT	15
MOWER DECK	16-17
BAGGER	18

**TRACTOR- -MODEL NO. BM115T92RB (96061002901), PRODUCT NO. 960 61 00-29
SCHEMATIC**

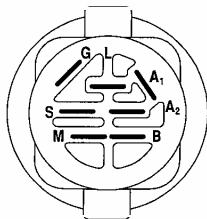
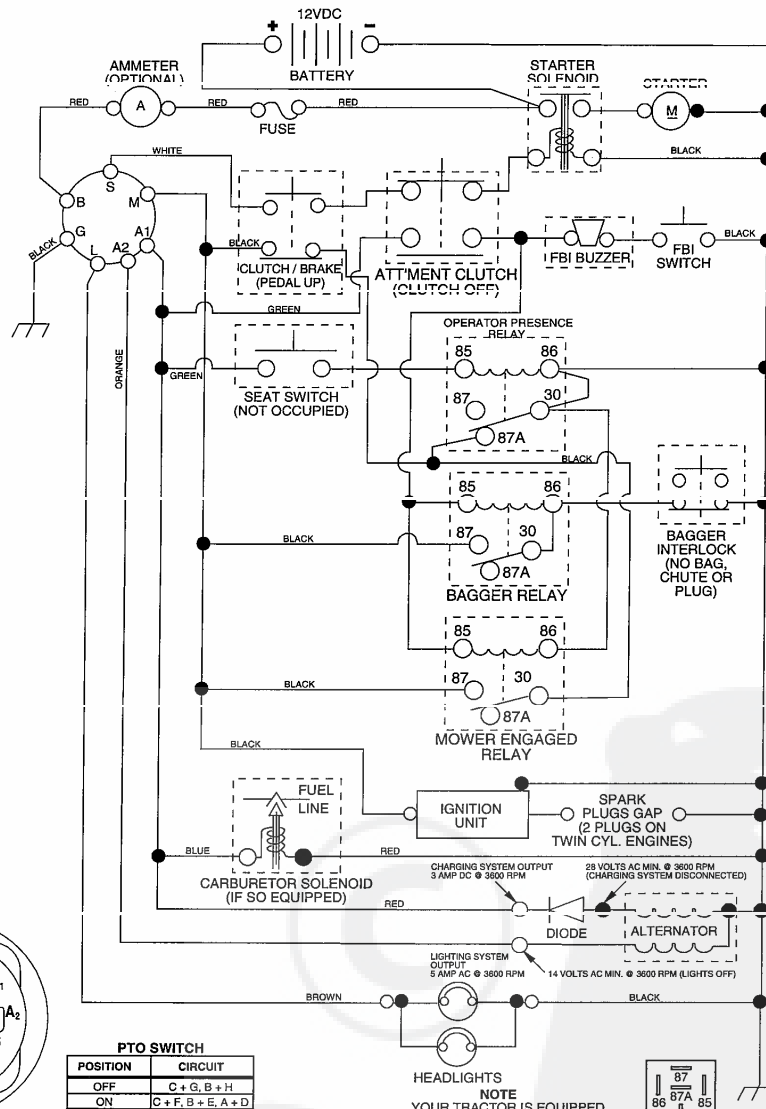

IGNITION SWITCH

POSITION	CIRCUIT	"MAKE"
OFF	M+G+A1	NONE
RUN/LIGHT	B+A1	A2+L
RUN	B+A1	NONE
START	B + S + A1	NONE

PTO SWITCH

POSITION	CIRCUIT
OFF	C + G, B + H
ON	C + F, B + E, A + D

WIRING INSULATED CLIPS
NOTE: IF WIRING INSULATED CLIPS WERE REMOVED FOR SERVICING OF UNIT, THEY SHOULD BE REPLACED TO PROPERLY SECURE YOUR WIRING.

02391

NON-REMOVABLE CONNECTIONS

REMOVABLE CONNECTIONS

HEADLIGHTS

NOTE
YOUR TRACTOR IS EQUIPPED WITH A SPECIAL ALTERNATOR SYSTEM. THE LIGHTS ARE NOT CONNECTED TO THE BATTERY, BUT HAVE THEIR OWN ELECTRICAL SOURCE. BECAUSE OF THIS, THE BRIGHTNESS OF THE LIGHTS WILL CHANGE WITH ENGINE SPEED. AT IDLE THE LIGHTS WILL DIM, AS THE ENGINE IS SPEEDED UP, THE LIGHTS WILL BECOME THEIR BRIGHTEST.



RELAY

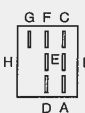

REPAIR PARTS

TRACTOR- -MODEL NO. BM115T92RB (96061002901), PRODUCT NO. 960 61 00-29
ELECTRICAL

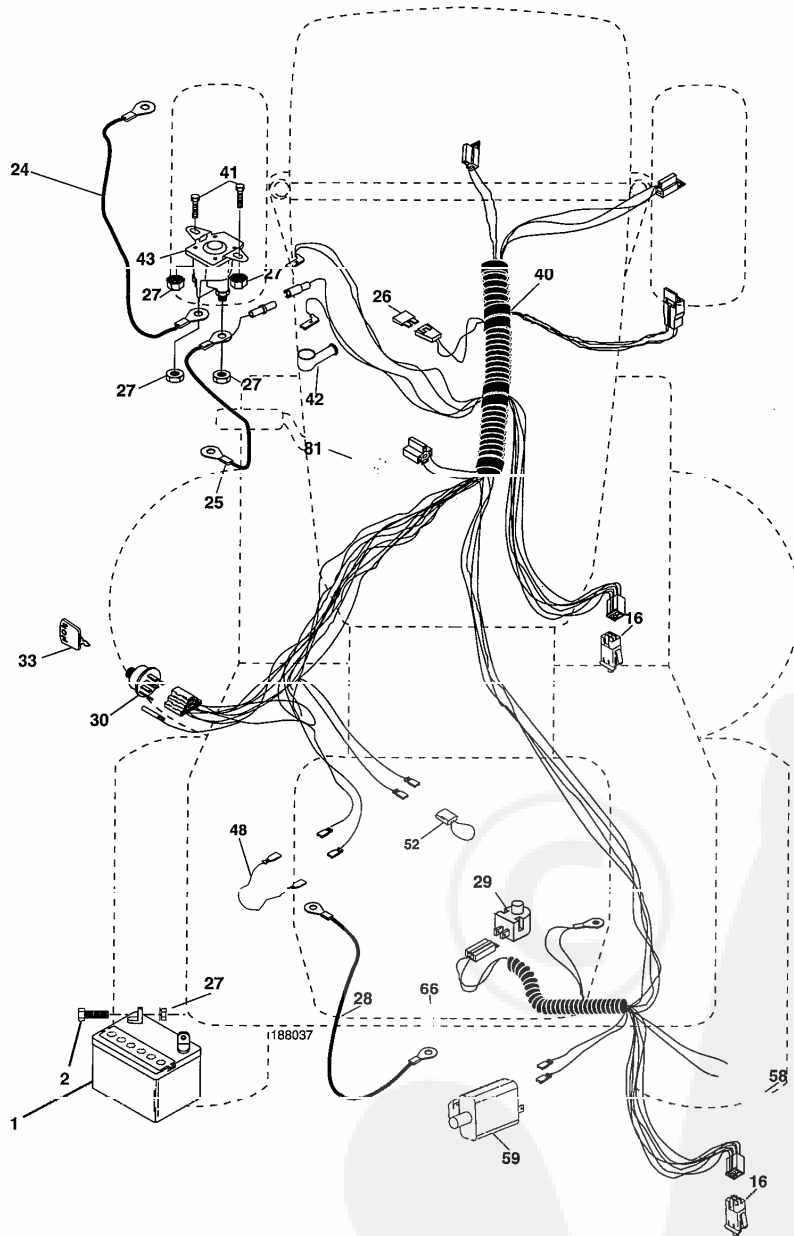

REPAIR PARTS

TRACTOR- -MODEL NO. BM115T92RB (96061002901), PRODUCT NO. 960 61 00-29
ELECTRICAL

KEY NO.	PART NO.	DESCRIPTION
1	532 16 34-65	Battery
2	874 76 04-12	Bolt Hex Hd 1/4-20 unc x 3/4
16	532 17 61-38	Switch Interlock
24	532 12 47-80	Cable Starter 6 Ga. 11" Red
25	532 16 59-87	Cable Battery Crd 56" Red
26	532 17 51-58	Fuse
27	873 51 04-00	Nut Keys Hex 1/4-20 unc
28	532 12 77-25	Cable Ground 6 Ga. 18" Black
29	532 12 13-05	Switch Plunger Normal OP Gray
30	532 17 55-67	Switch Ignition
33	532 14 04-01	Key Ign
40	532 18 80-37	Harness Ign
41	871 11 04-08	Bolt Flk Fin Hex 1/4-20 unc x 1/2
42	532 13 15-63	Cover Terminal Red
43	532 17 88-61	Solenoid
48	532 14 08-44	Adapter Ammeter Rectangular
52	532 14 10 40	Protection Wire Loop
58	532 16 94-19	Buzzer Crd
59	532 18 03-79	Switch FBI CRD
66	817 49 06-08	Screw Thdrol 3/8-16 x 1/2 Ty-Tt
81	532 10 97-48	Relay Asm

NOTE: All component dimensions given in U.S. inches.
1 inch = 25.4 mm.

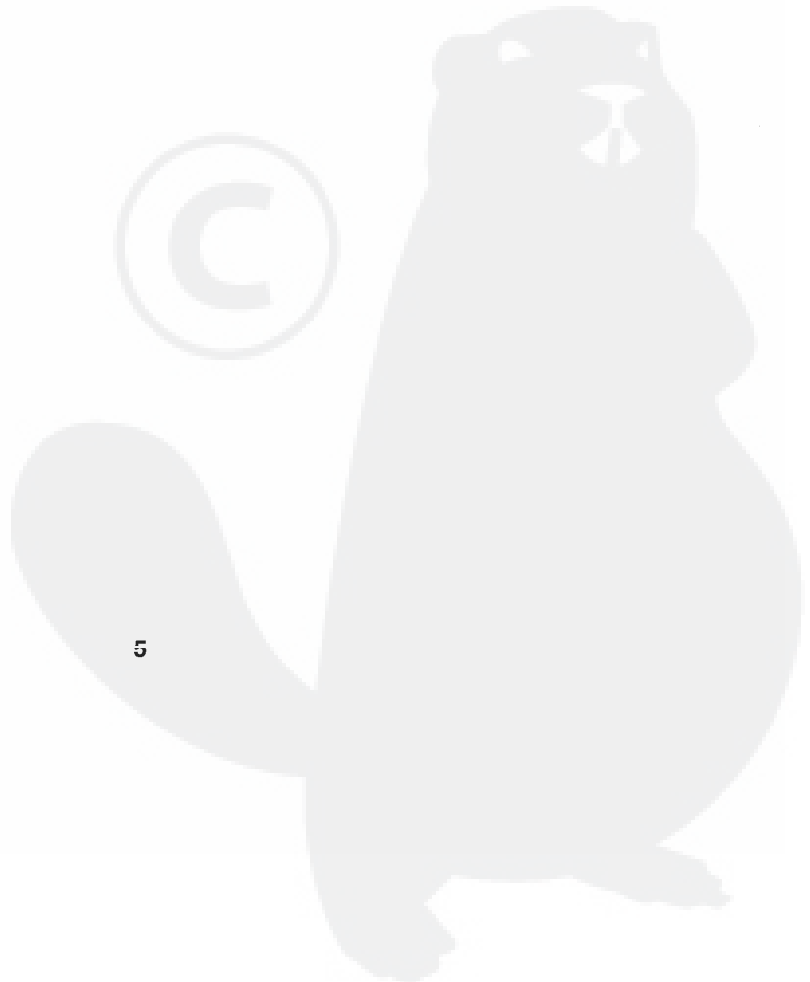
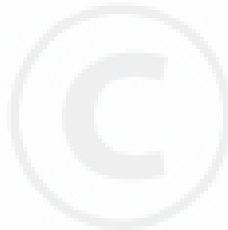

REPAIR PARTS

TRACTOR- -MODEL NO. BM115T92RB (96061002901), PRODUCT NO. 960 61 00-29
CHASSIS AND ENCLOSURES

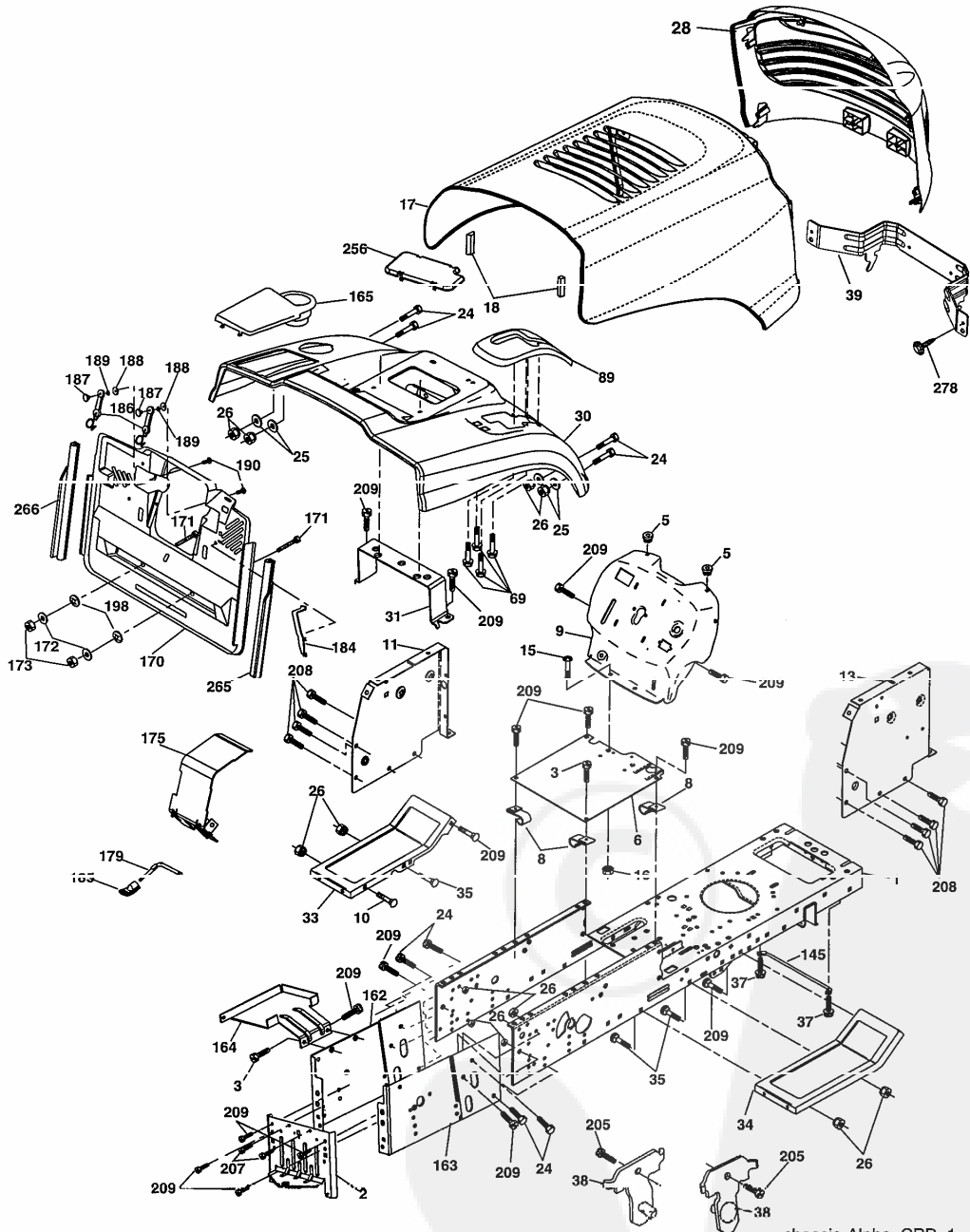

chassis-Alpha_CRD_1

REPAIR PARTS

TRACTOR- -MODEL NO. BM115T92RB (96061002901), PRODUCT NO. 960 61 00-29
CHASSIS AND ENCLOSURES

KEY NO.	PART NO.	DESCRIPTION	KEY NO.	PART NO.	DESCRIPTION
1	532 17 46-20	Chassis	163	532 18 03-83	Bracket Exten Chassis Rh CRD
2	532 18 03-84	Drawbar	164	532 16 56-05	Support Battery CRD
3	817 06 06-12	Screw 3/8-16 x 3/4	165	532 18 13-56	Cover Battery
5	532 15 52-72	Bumper Hood/Dash	170	532 17 88-62	Backplate Asm CRD
6	532 18 44-19	Saddle	171	872 14 06-20	Bolt Rdhd Sqnk 3/8-16 x 2-1/2 Gr. 5
8	532 12 64-71	Clip Insulator 13/32 Mtg. Hole	172	819 13 20-16	Washer 13/32 x 1-1/4 x 16 Ga.
9	532 19 46-88	Dash	173	873 51 06-00	Nut. Keps Hex 3/8-16 unc
10	872 14 06-08	Bolt, Carriage 3/8-16 x 3/4	175	532 18 82-03	Door Trap
11	532 17 49-96	Panel, Dash, L.H.	179	532 18 82-02	Rod Pivot FBI CRD
13	532 18 17-19	Panel, Asm. Dash R.H.	184	532 17 46-62	Bracket Actuator Bagger CRD
15	874 18 05-12	Screw, Machine, Truss Head 5/16-18 unc x 3/4	185	532 18 11-01	Knob Rod Brake Parking
16	873 51 05-00	Nut	186	532 16 07-93	Latch Asm Mulch/Bagger
17	532 19 47-97	Hood	187	532 00 20-29	Nut Weld
18	532 12 49-21	Bumper Hood	188	819 06 12-16	Washer #10
24	874 78 06-16	Bolt	189	810 07 10-00	Washer Lock #10
25	819 13 13 12	Washer 13/32 x 13/16 x 12 Ga.	190	871 08 10-10	Screw Pan Hd Phillip 10-24 x 5/8
26	873 80 06-00	Nut	192	532 16 99 27	Nut, Push
28	532 19 47-98	Grille	205	817 49 06-08	Screw Thdrol 3/8-16 x 1/2
30	532 19 73-44	Fender	207	817 67 05-08	Screw Thdrol 5/16-18 x 1/2
31	532 16 51-56	Bracket, Fender Support	208	817 67 06-08	Screw Thdrol 3/8-16 x 1/2
33	532 18 11-93	Footrest, L.H.	209	817 00 06-12	Screw Hex Wsh Thdrol 3/8-16
34	532 18 11-94	Footrest, R.H.	256	532 18 13-61	Cover Fender Rack CRD
35	872 11 06-06	Bolt	265	532 18 57-04	Seal RH Side Bagger
37	817 49 05-08	Screw Thdrol 5/16-18 x 1/2 TYT	266	532 18 57-03	Seal LH Side Bagger
38	532 18 17-48	Bracket Asm Pivot Mower Rear	278	532 19 16-11	Screw 10 x 3/4 Single Lead-Hex
39	532 18 75-66	Bracket Pivot	--	532 00 54-79	Plug
69	532 14 24-32	Screw Hex Wsh	--	532 19 39-35	Plug Switch Light
89	532 19 73-39	Console			
145	532 15 65-24	Rod Pivot Chassis/Hood			
162	532 18 03-82	Bracket Exten Chassis Lh CRD			

NOTE: All component dimensions given in U.S. inches.
1 inch = 25.4 mm.

REPAIR PARTS

TRACTOR- -MODEL NO. BM115T92RB (96061002901), PRODUCT NO. 960 61 00-29
DRIVE

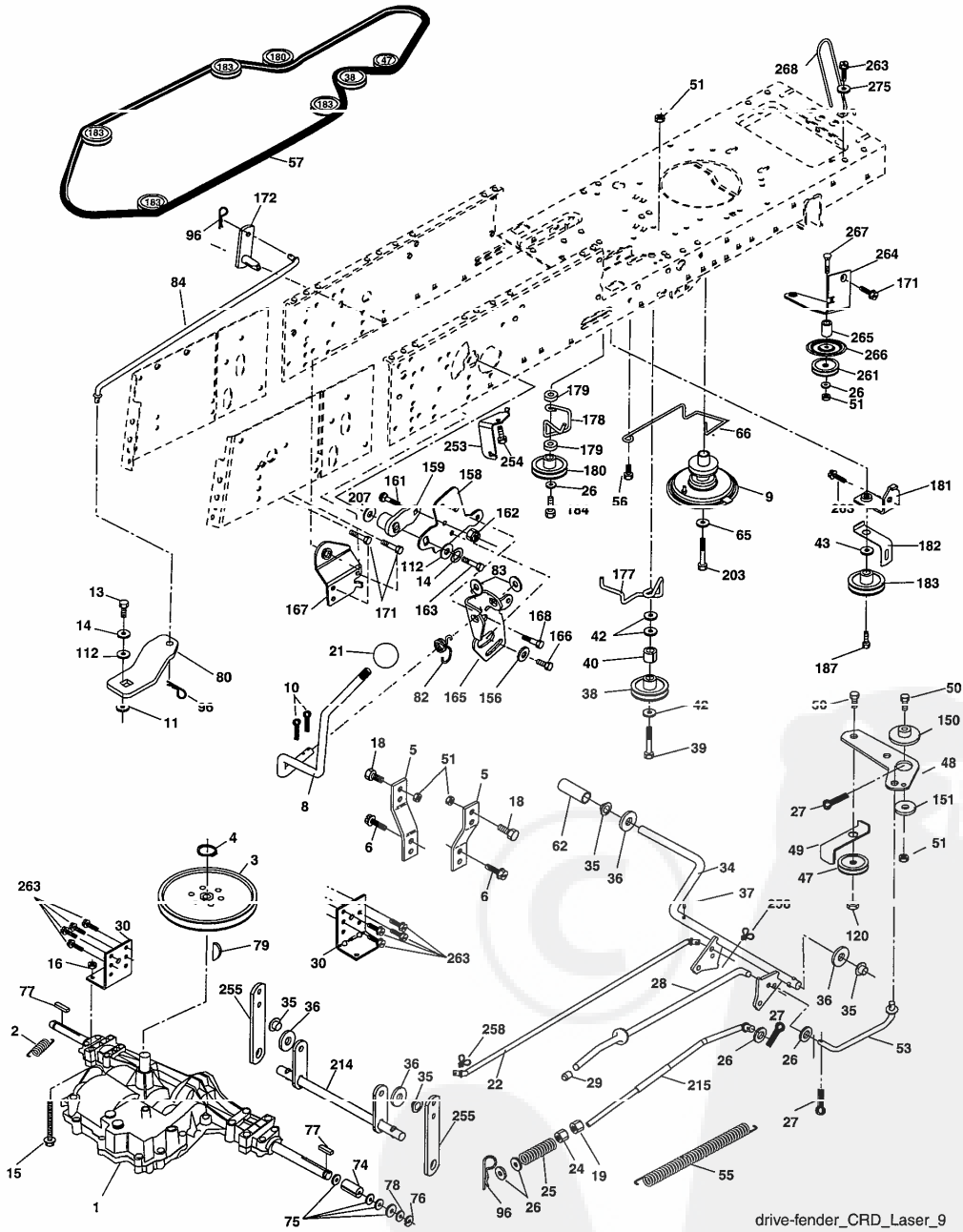

drive-fender_CRD_Laser_9

REPAIR PARTS

TRACTOR- -MODEL NO. BM115T92RB (96061002901), PRODUCT NO. 960 61 00-29 DRIVE

KEY NO.	PART NO.	DESCRIPTION	KEY NO.	PART NO.	DESCRIPTION
1	-----	Transaxle Peerless 206-546 Order parts from transaxle manufacturer	79	532 12 50-96	Key Woodruff
2	532 14 66-82	Spring Brake Return	80	532 14 50-90	Arm Shift PMST 20" Tires
3	532 16 59-99	Pulley Transaxle	82	532 16 57-11	Spring, Torsion
4	812 00 00-28	Ring Retainer #5100-62	83	819 17 12-16	Washer 17/32 x 3/4 x 16 Ga.
5	532 12 15-20	Strap torque 30 degrees	84	532 16 56-21	Link Shift CRD Pmst 18" Tires
6	817 06 05-12	Screw 5/16-18 x 3/4	96	532 12 47-88	Spring, Retainer 1"
8	532 16 56-19	Rod Shift Fender Adjust Lt	112	819 09 12-10	Washer 9/32 x 3/4 x 10 Ga.
9	532 18 03-54	Clutch Asm Noram	120	873 90 06-00	Nut Lock 3/8-16
10	876 02 04-16	Pin, Cotter 1/8 x 1	150	532 16 58-50	Bushing, Bellcrank Grnd Dr
11	532 10 57-01	Washer Plate Shf .3888 sq hole	151	819 13 32-10	Washer 13/32 x 2 x 10 Ga.
13	874 55 04-12	Bolt 1/4-28 unf Gr. 8 w/patch	156	532 16 60-02	Washer Srrred 5/16 ID x 1.125
14	810 04 04-00	Washer, Lock Hvy Helical	158	532 16 55-89	Bracket Shift Mount
15	874 49 05-44	Bolt Hex FGHD 5/16-18 x Gr. 5	159	532 18 39-00	Hub Tapered Flange Shift Lt
16	873 80 05-00	Nut, Lock Hex w/Ins 5/16-18 unc	161	872 14 04-06	Bolt Rdhd Sqnk 1/4-20 x 3/4 Gr. 5
18	874 78 06-16	Bolt Hex 3/8-16 unc x 1 Gr. 5	162	873 68 04-00	Nut Crownlock 1/4-20 unc
19	873 80 06-00	Nut, Lock Hex w/Wsh 3/8-16 unc	163	874 78 04-16	Bolt Hex Fin 1/4-20 unc x 1 Gr. 5
21	532 10 69-33	Knob Round 1/2-13 unc Blk	165	532 16 56-23	Bracket Pivot Lever
22	532 17 56-07	Rod, Brake CRD Main	166	817 49 05-10	Screw 5/16-18 x 5/8
24	873 35 06-00	Nut	167	532 16 55-88	Bracket Support Shift CRD
25	532 10 68-88	Spring, Rod, Brake	168	532 16 54-92	Bolt Shoulder 5/16-18 x .561
26	819 13 13-16	Washer 13/32 x 13/16 x 16 Ga.	171	817 49 06-08	Screw Thdrol 3/8-16 x 1/2 Ty-Tt
27	760 02 04-12	Pin, Cotter 1/8 x 3/4	172	532 16 56-35	Shaft Asm Shift Front CRD PMST
28	532 17 57-65	Rod, Parking Brake	177	532 16 59-32	Keeper Flat Idler 3.06" CRD
29	532 07 16-73	Cap, Parking Brake	178	532 16 59-33	Keeper Belt Idler 1.88" CRD
30	532 17 49-73	Bracket, Mfg. Transaxle	179	532 12 09-58	Washer Sintered
34	532 17 55-78	Shaft, Asm Pedal Foot CRD	180	532 16 56-30	Pulley Flat Composite 3.06"
35	532 12 01-83	Bearing, Nylon	181	532 18 02-11	Bracket Idler Ground Drive CRD
36	819 21 16-16	Washer 21/32 x 1 x 16 Ga.	182	532 18 26-82	Keeper Belt 2.5" Od V-Idler CRD
37	532 12 49-63	Pin, Roll 3/16 x 1"	193	532 18 60 07	Pulley V Idler 2.50" Od CRD
38	532 16 59-36	Pulley, Flat	184	817 49 06-44	Screw Hexwsh Thdrol 3/8-16 x 2-3/4
39	874 76 06-44	Bolt Fin Hex 3/8-16 unc x 2-3/4	187	817 58 05-20	Screw 5/16-18 x 1.25
40	532 12 49-65	Spacer, Split 395 x 59 Bzp	203	871 17 07-80	Bolt Hex 7/16-20 x 5
42	819 13 13-12	Washer 13/32 x 13/16 x 12 Ga.	207	532 16 98-45	Washer Nylon
43	819 11 10-12	Washer 11/32 x 5/8 x 12 Ga.	214	532 17 56-09	Shaft Asm. Brake
47	532 12 77-83	Pulley, Idler, V Groove Plasic	215	532 17 56-51	Rod Brake Secondary
48	532 15 44-07	Bellcrank Clutch Grnd Drv	253	532 17 50-28	Bracket Cable Chassis
49	532 12 32-05	Retainer, Bell Styie Spring	254	817 00 06-16	Screw 3/8-16 x 1
50	872 11 06-12	Bolt Carr Sh 3/8-16 x 1-1/2 Gr. 5	255	532 17 56-08	Brace Shaft Brake
51	873 68 06-00	Nut, Crownlock 3/8-16 unc	258	532 17 80-62	Clip Retainer
53	532 10 57-10	Link, Clutch 7.66	261	532 13 14-94	Pulley Idler Flat Plated
55	532 10 57 09	Spring, Return, Clutch	263	817 00 06-12	Screw Hex Wsh THDR 3/8-16 x 3/4
56	817 06 06-20	Screw 3/8-16 x 1-1/4	264	532 18 19-95	Bracket Clutch
57	532 16 56-31	V-Belt Kev PMST CRD	265	532 18 20-13	Spacer Idler Chassis
62	532 12 48-72	Cover, Pedal	266	532 18 20-61	Shield Idler
65	810 04 07-00	Washer	267	872 14 06-26	Bolt Rd Sqk 3/8-16 x 3-1/4
66	532 15 47-78	Keeper, Belt Engine F-Proof	269	532 18 24-02	Guard Muffler OHV B&S RH
74	532 13 70-57	Spacer Axle	275	819 13 16-14	Washer 13/32 x 1 x 1/4 Ga.
75	532 12 17-49	Washer 25/32 x 1-1/4 x 16 Ga.			
76	812 00 00-01	Ring, E			
77	532 12 35-83	Key, Square			
78	532 12 17-48	Washer 25/32 x 1-5/8 x 16 Ga.			

NOTE: All component dimensions given in U.S. inches
1 inch = 25.4 mm

REPAIR PARTS

TRACTOR- -MODEL NO. BM115T92RB (96061002901), PRODUCT NO. 960 61 00-29
STEERING ASSEMBLY

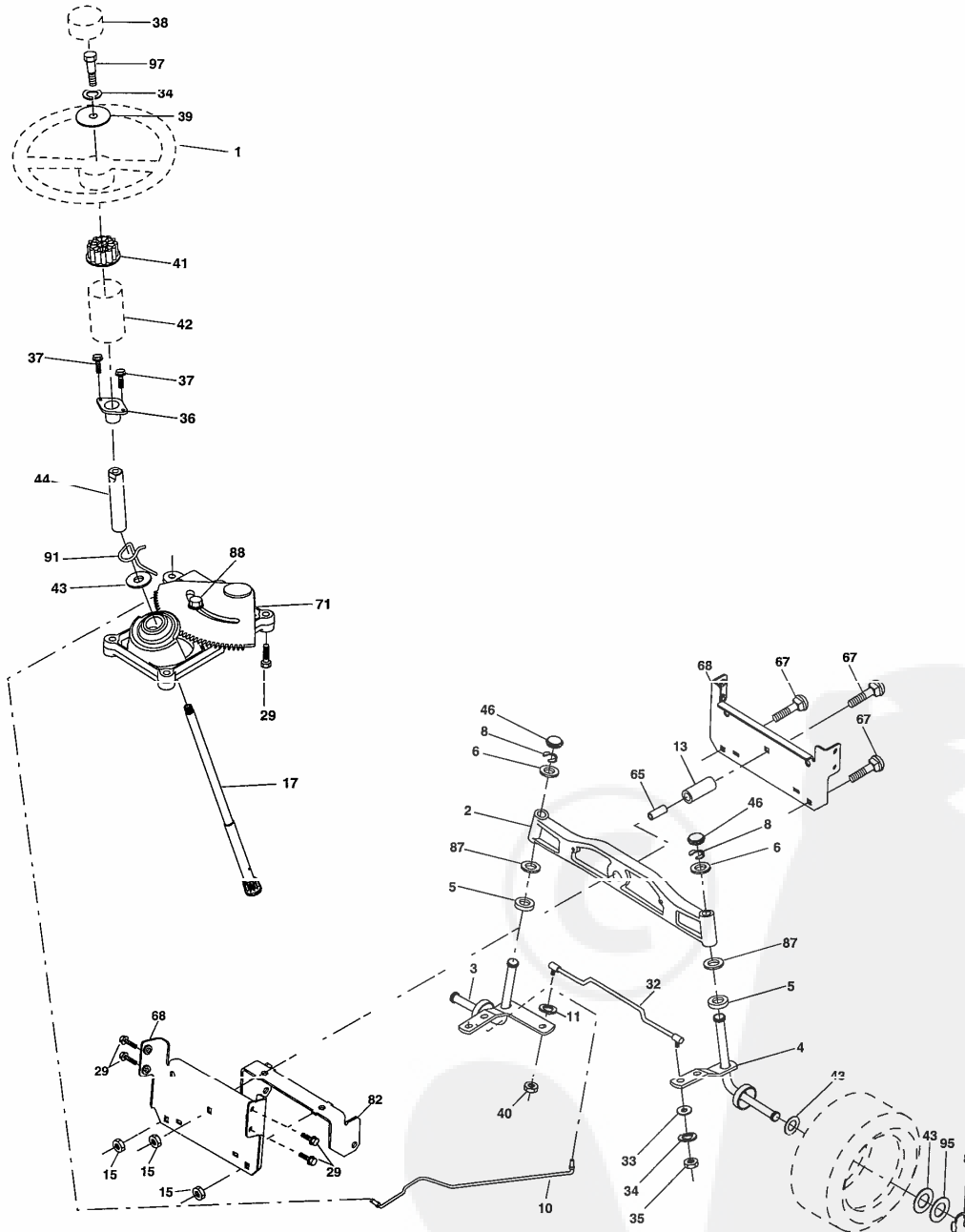

steering_pl.lt_60

REPAIR PARTS

TRACTOR- -MODEL NO. BM115T92RB (96061002901), PRODUCT NO. 960 61 00-29
STEERING ASSEMBLY

KEY NO.	PART NO.	DESCRIPTION
1	532 18 76-90	Steering Wheel
2	532 18 47-06	Front Axle Assembly
3	532 16 98-40	Spindle Assembly, L.H.
4	532 16 98-39	Spindle Assembly, R.H.
5	532 12 49-31	Bearing, Race, Thrust, Hardened
6	532 12 17-48	Washer 25/32 x 1-5/8 x 16 Ga.
8	812 00 00-29	Ring, Klip
10	532 17 51-21	Link, Drag
11	810 04 06-00	Washer, Lock
13	532 13 65-18	Spacer Axle
15	532 14 52-12	Nut Hex Flange Lock
17	532 19 07-53	Shaft Assembly, Steering
29	817 00 06-12	Screw 3/8-16 x 3/4
32	532 17 01-62	Rod, Tie
33	819 11 12-16	Washer 11/32 x 3/4 x 16 Ga.
34	810 04 05-00	Washer Lock Hvy Hlcl Spr 5/16
35	873 54 05-00	Crownlock Nut 5/16-24 unf
36	532 15 50-99	Bushing, Steering
37	532 15 29-27	Screw TT #10-32 x 5 x 3/8 Flange
38	532 19 29-16	Cap Wheel Steer
39	819 11 38-12	Washer 11/32 ID x 2-3/8 OD 12 Ga.
40	873 54 06-00	Nut Crownlock 3/8-24
41	532 18 67-37	Adaptor, Steering Wheel
42	532 16 96-33	Boot, Steering Dash P/L Mtl
43	532 12 17-49	Washer 25/32 x 1-1/4 x 16 Ga.
44	532 19 07-52	Extension Steering
46	532 12 12-32	Cap, Spindle
65	532 16 03-67	Spacer Axle
67	872 11 06-18	Bolt Rdhd Sq 3/8-16 x 2-1/4
68	532 16 98-27	Brace Axle
71	532 17 51-46	Steering Asm.
82	532 16 98-35	Bracket Susp. Chassis Front
87	532 17 39-66	Washer Flat .781 x 1-1/2 x .14
88	532 17 51-18	Bolt Shoulder 7/16-20 unc
91	532 17 55-53	Clip Steering
95	532 18 89-67	Washer
97	874 78 05-64	Bolt 5/16-18 unc x 4" L Gr. 5

NOTE: All component dimensions given in U.S. inches.
1 inch = 25.4 mm.

REPAIR PARTS

TRACTOR- -MODEL NO. BM115T92RB (96061002901), PRODUCT NO. 960 61 00-29
SEAT ASSEMBLY

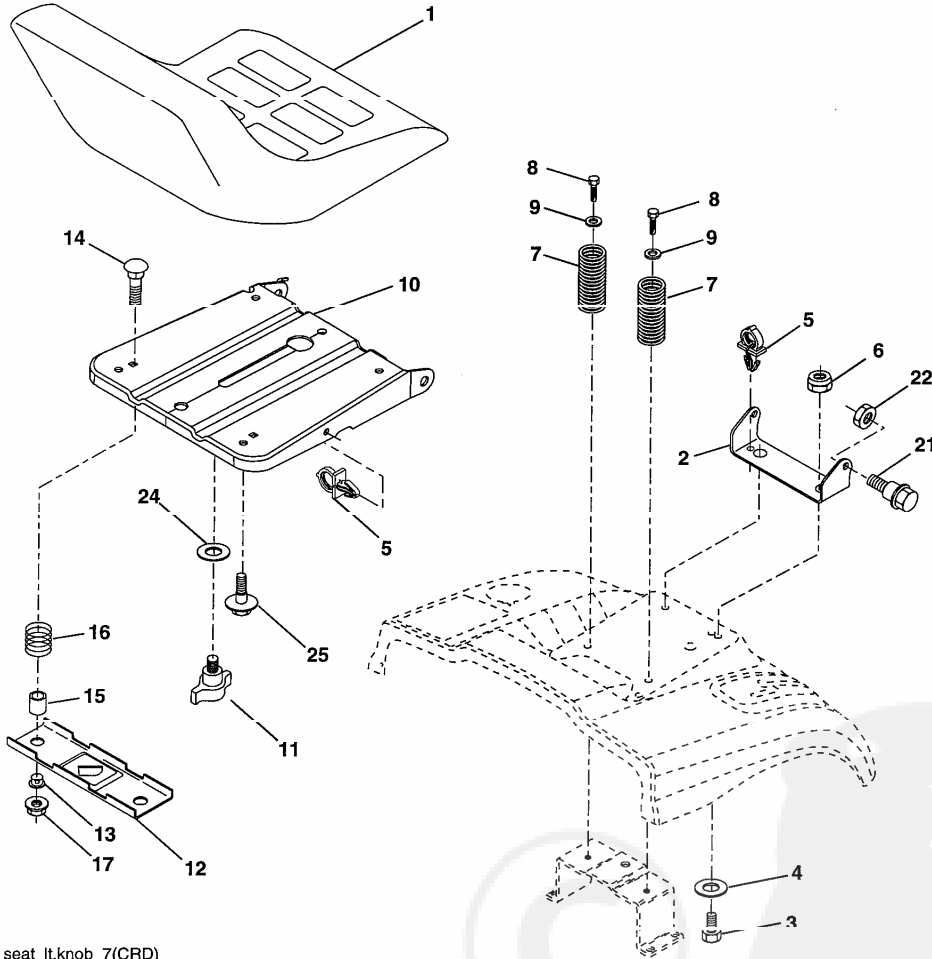

seat_it.knob_7(CRD)

KEY NO.	PART NO.	DESCRIPTION
1	532 17 53-89	Seat
2	532 14 05-51	Bracket Pivot Seat
3	871 11 06-16	Bolt Fin Hex 3/8-16 x 1 Blk
4	819 13 16-10	Washer Flat 13/32 x 1 x 10 Ga.
5	532 14 50-06	Clip Push In Hinged
6	873 80 06-00	Nut Lock Hex w/Insert 3/8-16
7	532 12 41-81	Spring Seat Cprsn 2 250 Blk Zi
8	817 00 06-16	Screw 3/8-16 x 1.5
9	819 13 16-14	Washer 13/32 x 1 x 14 Ga.
10	532 18 24-93	Pan Seat
11	532 16 63-69	Knob Seat Adj. Wingnut
12	532 12 12-46	Bracket Pnt Mounting Switch

KEY NO.	PART NO.	DESCRIPTION
13	532 12 12-48	Bushing Snap Blk Nyl 50 Id
14	872 05 04-12	Bolt Rdhd Sht Nk 1/4-20 x 1-1/2
15	532 13 43-00	Spacer Split
16	532 12 12-50	Spring Cprsn
17	532 12 39-76	Nut Lock 1/4 Lge Flg Gr. 6 Zinc
21	532 17 18-52	Bolt Shoulder 5/16-18 unc-2A
22	873 80 05-00	Nut Hex Lock w/Ins 5/16-18
24	819 17 19-12	Washer 17/32 x 1-3/16 x 12 Ga.
25	532 12 70-18	Bolt Shoulder 5/16-18 x .62

NOTE: All component dimensions given in U.S. inches.
1 inch = 25.4 mm

REPAIR PARTS

TRACTOR- -MODEL NO. BM115T92RB (96061002901), PRODUCT NO. 960 61 00-29
DECALS

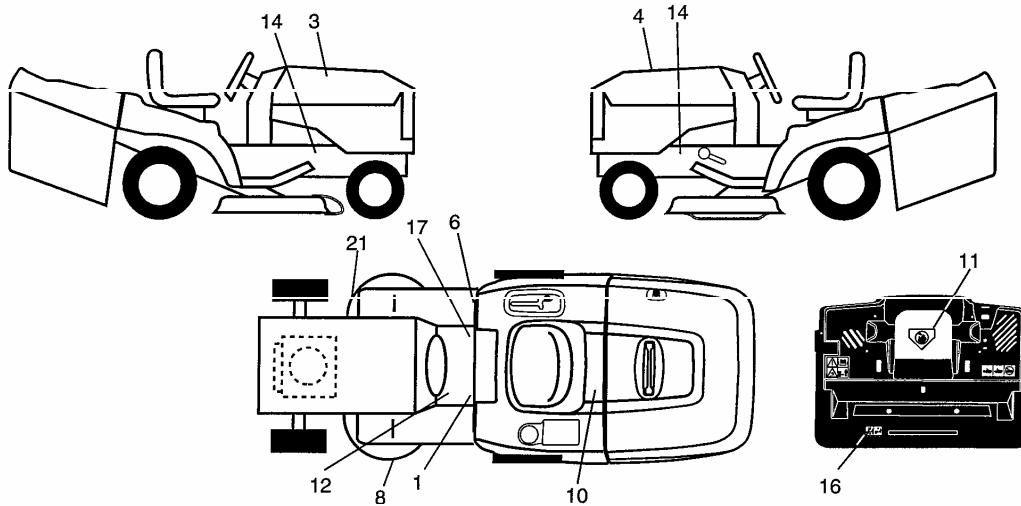

KEY NO.	PART NO.	DESCRIPTION
1	532 14 54-98	Decal Read Owner's Manual Sym
3	532 19 44-26	Decal Hood RH
4	532 19 44-27	Decal Hood LH
6	532 18 04-32	Decal 100 DBA/CE
8	532 18 78-11	Decal Deck Enviro
10	532 14 50-05	Decal Bat Dan/Poi P/L Sym Wpn
11	532 18 21-66	Decal Mower Cut Finger Symbol
12	532 15 97-37	Decal Brake/Clutch Symbol Lt
14	532 15 97-36	Decal Chassis Hot Muffler

KEY NO.	PART NO.	DESCRIPTION
16	532 18 04-35	Decal Backplate
17	532 14 08-37	Decal Saddle Brake Parking
21	532 16 62-86	Decal Hex Belt Sch 92 CRD
—	532 18 26-21	Decal Bagger Frame
—	532 13 83-11	Decal Lift Handle
—	532 19 70-87	Manual Operator's (Euro)
—	532 19 70-88	Manual Operator's (Fori)
—	532 19 70-89	Manual Operator's (Polish)
—	532 19 70-90	Manual Parts

WHEELS & TIRES

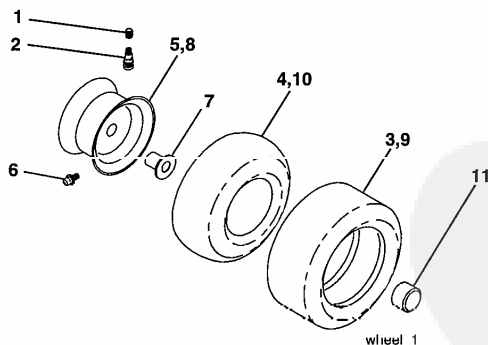

KEY NO.	PART NO.	DESCRIPTION
1	532 05 91-92	Cap Value Tire
2	532 06 51-39	Stem Value
3	532 10 62-22	Tire F Ts 15 x 6 0 - 6 Service
4	532 05 99-04	Tube Inner Front #35060
5	532 13 83-36	Rim Asm 6" front Service
6	532 12 49-57	Fitting Grease
7	532 12 49-59	Bearing Flange
8	532 13 83-37	Rim Asm 8" rear Service
9	532 10 62-68	Tire R Ts 18 x 5-8 Service
10	532 12 49-26	Tube Rear 9 5 x 8 Service
11	532 17 50-39	Cap Axle Blk 1 50 x 1 00
--	532 14 43-34	Sealant, Tire (10 oz. tube)

NOTE: All component dimensions given in U.S. inches
1 inch = 25.4 mm

REPAIR PARTS

TRACTOR- -MODEL NO. BM115T92RB (96061002901), PRODUCT NO. 960 61 00-29
ENGINE

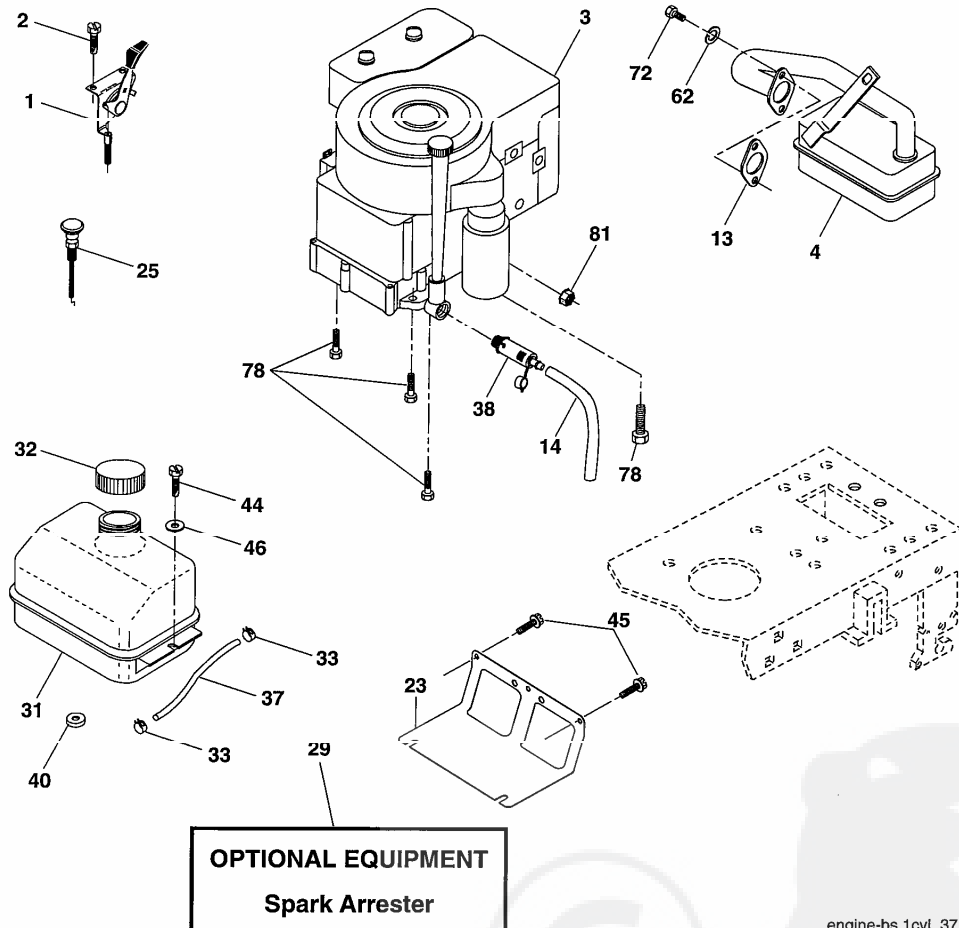

engine-bs.1cyl_37

KEY NO.	PART NO.	DESCRIPTION	KEY NO.	PART NO.	DESCRIPTION
1	532 17 05-51	Control Throttle	33	532 12 34-87	Clamp Hose Blk
2	817 72 04-08	Screw Hex Thd Cut 1/4-20 x 1/2	37	532 13 70-40	Line Fuel 20"
3	-----	Engine B&S Model 217707 (Order Parts from Engine Manufacturer)	38	532 18 16-54	Plug Drain Oil Easy
4	532 17 97-58	Muffler Exhaust B&S Lt	40	532 12 40-28	Bushing Snap
13	532 16 52-91	Gasket 1 313 Id Tin Plated	44	817 07 04-12	Screw Hexwsh Thdrol 5/8-16 x 3/4
14	532 14 84-56	Tube Drain Oil Easy	45	817 00 06-12	Screw 3/8-16 x 3/4
23	532 16 98-37	Shield Browning/Debris Guard	46	819 09 14-16	Washer 9/32 x 7/8 x 16 Ga.
25	532 19 06-95	Control Choke	62	810 04 01-00	Washer Lock 5/16
26	873 92 06-00	Nut Keps 3/8-24 unf.	72	871 07 05-12	Screw Hex Hd Cap 5/16-18 x 3/4
29	532 13 71-80	Arrester Spark	78	817 06 06-20	Screw 3/8-16 x 1-1/4
31	532 18 77-50	Tank Fuel	81	873 51 04-00	Nut Keps Hex 1/4-20 unc
32	532 14 05-27	Cap Asm Fule Top Vent N/Lany			

NOTE: All component dimensions given in U.S. inches
1 inch = 25.4 mm

REPAIR PARTS

TRACTOR- -MODEL NO. BM115T92RB (96061002901), PRODUCT NO. 960 61 00-29
MOWER LIFT

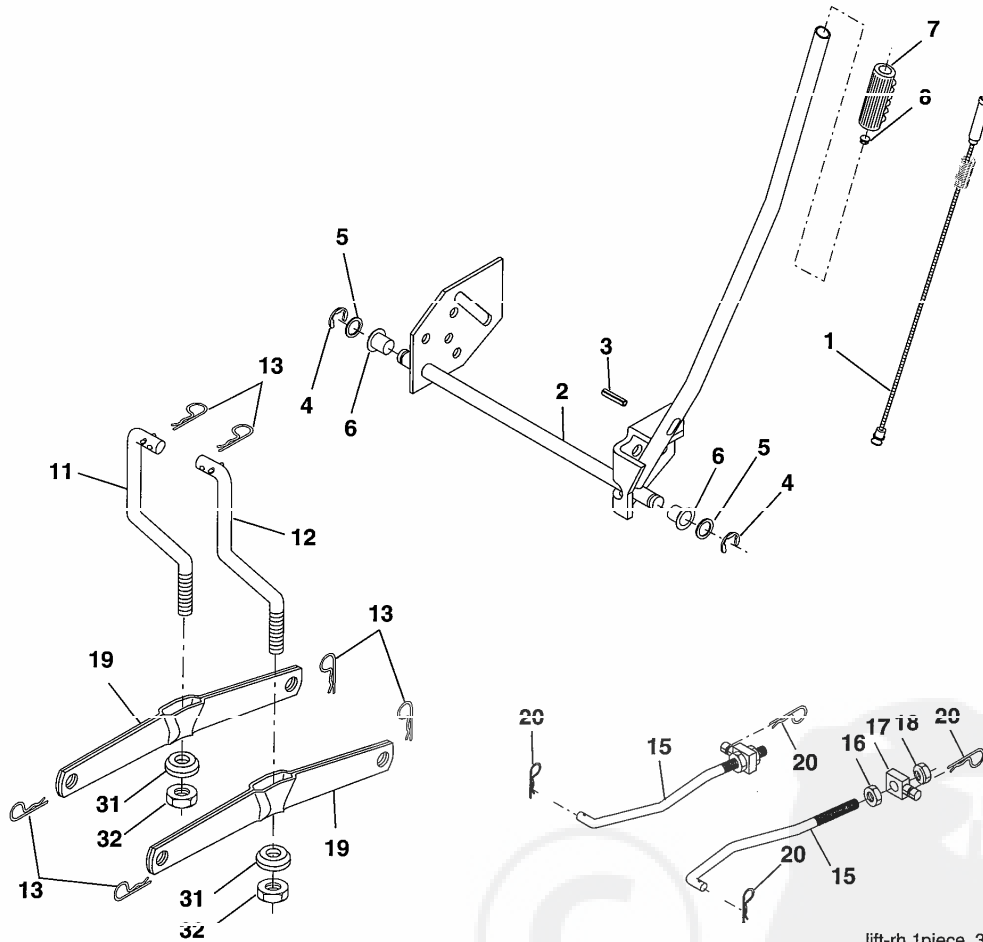

lift-rh.1piece_3

KEY NO.	PART NO.	DESCRIPTION
1	532 15 94-60	Washer Asm Inner Spring W/ Plunger
2	532 15 94-71	Shaft Asm. Lift
3	532 10 57-67	Pin Groove
4	812 00 00-02	E Ring #5133-62
5	819 21 16-21	Washer 21/32 x 1 x 21 Ga.
6	532 12 01-83	Bearing Nylon
7	532 10 94-13	Grip Handle
8	532 12 45-26	Button Plunger Black
11	532 16 58-29	Link Asm Lift L.H.
12	532 16 58-31	Link Asm Lift R.H.
13	532 12 46-70	Retainer Spring

KEY NO.	PART NO.	DESCRIPTION
15	532 17 32-88	Link Front
16	873 35 08-00	Nut Jam Hex 1/2-13 unc
17	532 17 50-09	Trunnion Disk Zinc
18	873 80 08-00	Nut Lock w/wsh 1/2-13 unc
19	532 13 98-68	Arm Suspension Mower
20	532 16 35-52	Retainer Spring
31	532 16 98-65	Bearing, Pvt. Lift.
32	873 54 06-00	Nut Crownlock 3/8-24

NOTE: All component dimensions given in U.S. inches
1 inch = 25.4 mm

REPAIR PARTS

TRACTOR- -MODEL NO. BM115T92RB (96061002901), PRODUCT NO. 960 61 00-29
MOWER

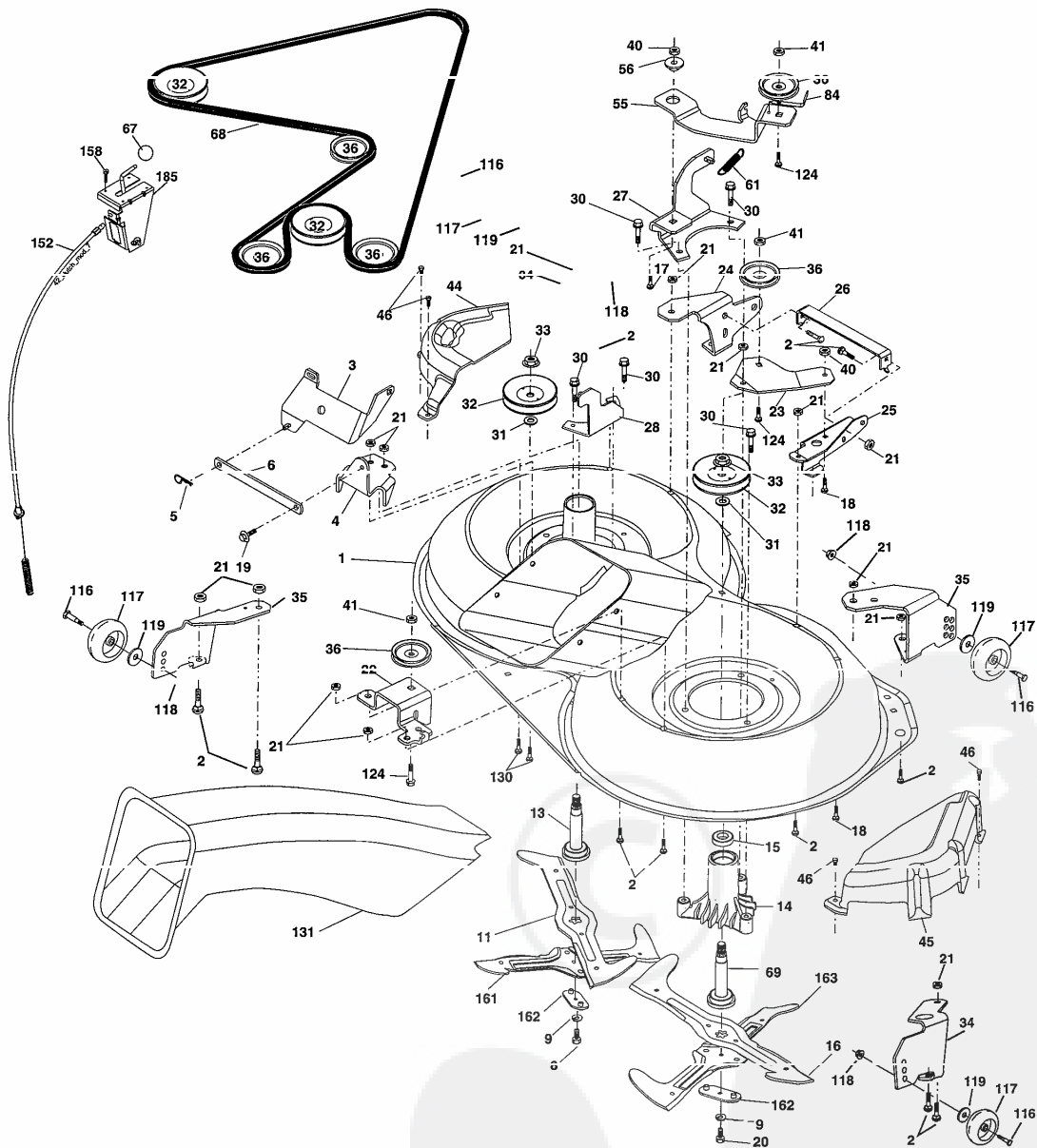

36(92cm)_deck-elect.(CRD)_1
36 GW med/wide/std

REPAIR PARTS

TRACTOR- -MODEL NO. BM115T92RB (96061002901), PRODUCT NO. 960 61 00-29
MOWER

KEY NO.	PART NO.	DESCRIPTION	KEY NO.	PART NO.	DESCRIPTION
1	532 16 55-52	Housing Asm. Mower	41	873 90 06-00	Nut Lock Flg. 3/8-16 UNC
2	872 14 05-06	Bolt Rdhd Sqnk 5/16-18 unc x 3/4	44	532 17 55-38	Cover Mandrel Lh
3	532 16 55-69	Bracket Asm. S-Bar Chass	45	532 17 55-39	Cover Mandrel Rh
4	532 16 55-58	Bracket Bar Sway Deck	46	532 13 77-29	Screw Thd Roll 1/4-20 x 5/8
5	532 12 46-70	Retainer Spring	55	532 16 54-45	Arm Idler
6	532 16 55-57	Bar Sway	56	532 16 57-23	Spacer Retainer PM Mower
8	532 18 17-12	Bolt 3/8-24 x 1.25 Gr. 9 Patched	61	532 16 50-45	Spring Tension Belt
9	810 03 06-00	Washer Lock Hvy 3/8 Unplated	67	532 10 69-32	Knob Rd 3/8-16 Plstc Thds Blk
11	532 18 63-85	Blade 3-1 Lh	68	532 18 02-17	Hex-Belt 92 Mower
13	532 13 76-45	Shaft Asm. W/Lower Bearing	69	532 16 54-82	Shaft Asm W/Lwr Brg Rh Thd CRD
14	532 12 87-74	Housing Mandrel Vented (Machd)	84	532 15 60-85	Keeper Belt Idler
15	532 11 04-85	Bearing Ball Mandrel	116	532 18 42-19	Bolt Shoulder
16	532 18 63-86	Blade 3-1 Rh	117	532 17 48-73	Wheel Gauge
17	872 14 06-10	Bolt Carriage 3/8-16 x 1-1/4	118	873 93 06-00	Nut Centerlock 3/8-16 unc
18	872 11 06-06	Bolt Rdhd Sqnk 3/8-16 x 3/4	119	819 12 14-14	Washer 3/8 x 7/8 x 14 Ga.
19	532 13 28-27	Bolt Shoulder 5/16-18 Thd Form	124	872 11 06-12	Bolt Carr Sh 3/8-16 x 1-1/2 Gr. 5
20	532 16 17-13	Bolt 3/8-24 x 1.25 Gr. 6 Fitch Linuü	130	872 11 05-06	Bolt Mandsqnk 5/16-18 unc x 3/4
21	873 68 05-00	Nut Crown Lock 5/16-18	131	532 16 56-61	Chute Bagger CRD
22	532 16 52-43	Bracket Idler Sprt RR	152	532 17 60-74	Cable Clutch CRD Service
23	532 16 54-46	Bracket Idler Sprt RF	158	817 72 04-08	Screw Hex Thdcut 1/4-20 x 5/8
24	532 16 52-42	Bracket Suspension LF	161	532 18 63-87	Blade Cross Lh 92
25	532 16 52-44	Bracket Suspension RF	162	532 18 08-78	Adpater Blade Cross
26	532 16 52-37	Brace Support Susp Frt CRD	163	532 18 63-88	Blade Cross Rh 92
27	532 16 55-68	Bracket Asm. Susp RR	185	532 18 82-34	Head Asm. Cable Clutch
28	532 16 55-67	Bracket Asm. Susp LR	--	532 18 18-57	Mandrel Asm Service
30	532 17 39-84	Screw Thd Rolling Washer Head	--	532 18 18-58	Mandrel Asm CRD Lh Threads SVC
31	532 18 76-90	Washer Spacer	--	532 18 85-23	Replacement Mower Complete- - (Std. Deck - Order separately gauge wheel components Key Nos. 116-119)
32	532 15 35-31	Mandrel Pulleys 36 & 46			
33	532 17 83-42	Nut Flg Top Lock			
34	532 16 52-39	Bracket Gauge Wheel Lf			
35	532 16 52-38	Bracket Gauge Wheel Rf			
36	532 14 67-63	Pulley Idler V-Groove Dim 4.25			
40	873 68 06-00	Nut lock 3/8-16 unc			

NOTE: All component dimensions given in U.S. inches
1 inch = 25.4 mm

REPAIR PARTS

TRACTOR- -MODEL NO. BM115T92RB (96061002901), PRODUCT NO. 960 61 00-29
BAGGER

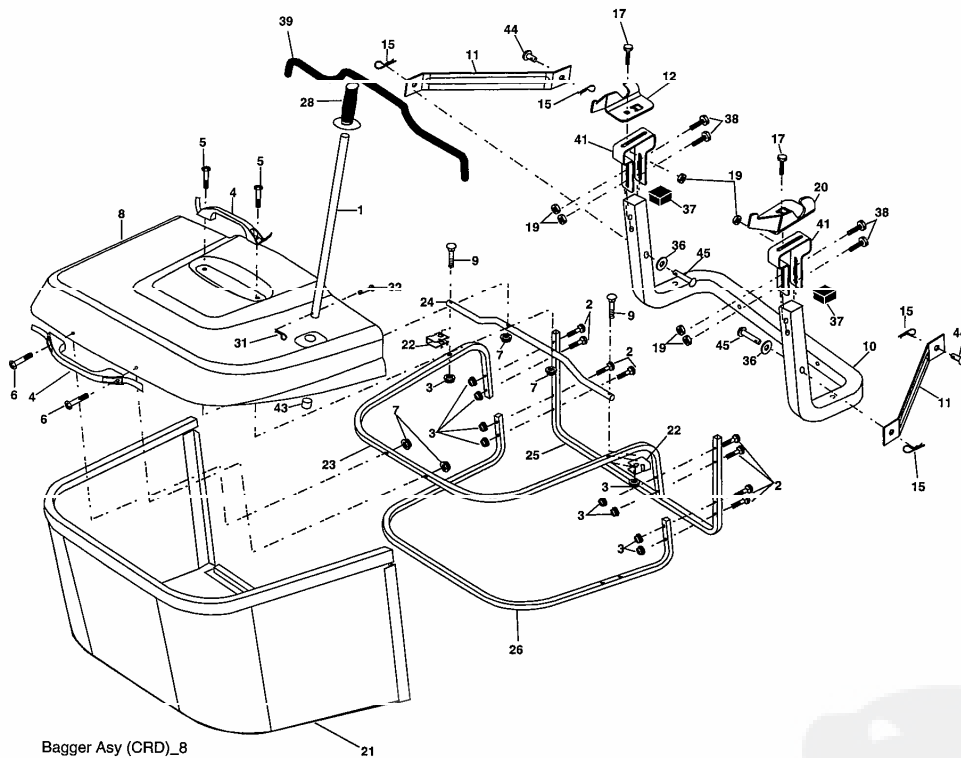

Bagger Asy (CRD)_8

KEY NO.	PART NO.	DESCRIPTION	KEY NO.	PART NO.	DESCRIPTION
1	532 16 52-49	Tube Handle Bagger CRD	21	532 18 08-80	Bag Asm CRD
2	872 14 04-16	Bolt Carriage 1/4-20 x 2.0 Gr. 5	22	532 16 57-81	Bracket Side Bagger CRD
3	532 12 39-76	Nut Lock 1/4 Lge Flg Gr. 5 Zinc	23	532 16 57-82	Tube Upper Bagger CRD
4	532 10 00-10	Handle Bagger w/Lvrs Dik CRD	24	532 16 57-83	Tube Pivot Bagger CRD
5	874 98 10-24	Screw Pan Head #10-24 x 1.50 Blk	25	532 18 01-24	Tube Front Bagger CRD
6	874 98 10-32	Screw Pan Hd	26	532 16 57-85	Tube Lower Bagger CRD
7	873 40 10-00	Nut Wiz Lock Hex Serr/Hd 10-24	28	532 16 57-87	Grip Handle Black
8	532 18 13-54	Cover Bagger	31	532 16 94-84	Retainer Clip
9	872 14 04-18	Bolt Carriage 1/4-20 x 2.25 d x Gr. 5	32	532 12 68-75	Rivet Rd Hd Drilled 3/8 Dia
10	532 18 12-82	Tube Support Bagger CRD	36	819 13 20-12	Washer 13/32 x 1-1/4 x 12 Ga.
11	532 16 57-19	Bracket Support Upper Bag CRD	37	532 17 54-01	Plug Support Bagger CRD
12	532 18 88-48	Bracket Pivot LH	38	872 01 05-20	Bolt 5/16-18 x 2-1/2
15	532 12 46-70	Retainer Spring	39	532 18 09-85	Seal Trim
17	872 14 05-06	Bolt Rdhd Sht Sqnk 5/16 -18 unc x 3/4	41	532 16 06-93	Bracket Pnt Adj Pvt Bagger CRD
19	873 90 05-00	Nut Lock Hex Flange 5/16-18	43	532 17 40-83	Plug Tubing End
20	532 18 88-47	Bracket Pivot RH	44	532 19 33-14	Pin Clevis 3/8 x 11/16
			45	532 19 33-13	Pin Clevis 3/8 x 2.00

NOTE: All component dimensions given in U.S. inches
1 inch = 25.4 mm



SERVICE POLICY WARRANTY



Issued January 1980
Revised January 1991

LIMITED WARRANTIES FOR NEW PEERLESS GEAR POWER TRAIN COMPONENTS

A. Products Warranted

Peerless Gear and Machine Division of Tecumseh Products Company ("Tecumseh"), subject to the limitations contained below, will, at its option, repair or replace, without charge for parts or labor only, any part of a new Power Train Component (which as used herein means and includes the transaxle, gear box, transmission, differential and right angle drives, and any part of the Power Train Component), EXCEPT any new Power Train Component incorporated in equipment used for commercial or rental purposes, which is found upon examination by any Tecumseh Authorized Service Outlet or by Tecumseh's factory in Grafton, Wisconsin, to be DEFECTIVE IN MATERIAL AND/OR WORKMANSHIP if received by Tecumseh or a Tecumseh Authorized Service Outlet for such examination within TWO YEARS from the date of sale to the original consumer purchaser of Peerless Series 820, 900, 910, 915, 920, 930 transaxles and Series 1100 angle drive and ONE YEAR for all other Peerless products. New Power Train Components incorporated in equipment used for commercial purposes are warranted in the same manner and to the same extent EXCEPT such Power Train Components are warranted for NINETY (90) DAYS ONLY, and must be received by Tecumseh or by a Tecumseh Authorized Service Outlet for such examination within 90 days from the date of sale to the original purchaser. New Power Train Components Incorporated in equipment used for rental purposes are warranted in the same manner and to the same extent EXCEPT such Power Train Components are warranted for THIRTY (30) DAYS ONLY, and must be received by Tecumseh or a Tecumseh Authorized Service Outlet within 30 days from the date of sale to the original purchaser.

B. Products And Items Not Warranted

1. Alterations or Modifications of Power Train Components.
2. Accidents, Normal Maintenance, Failure to follow the Original Equipment Manufacturer's Manual.

This warranty covers only parts of new Power Train Components which are found upon examination to be defective in material or workmanship as delivered to the original purchaser. This warranty does not cover defects caused by depreciation or damage caused by normal wear, accidents, improper maintenance, improper use or abuse of the product, failure to follow the instructions contained in an Instruction Manual for the operation of the Power Train Component and parts. The cost of normal maintenance and replacement of service items which are not defective shall be paid for by the original purchaser.

C. Securing Warranty Service

Warranty service can be arranged for by contacting either a Tecumseh Authorized Service Outlet (any Tecumseh Registered Service Dealer, Tecumseh Authorized Service Distributor, or Tecumseh Central Warehouse Distributor) or by contacting Tecumseh, c/o Service Manager, Engine and Transmission Group Service Division, 900 North Street, Grafton, Wisconsin 53024. Warranty service can only be performed by a Tecumseh Authorized Service Outlet or by Tecumseh at its factory in Grafton, Wisconsin. At the time of requesting warranty service, evidence must be presented of the date of sale to the original purchaser. The purchaser shall pay any charges for making service calls and/or for transporting the product to and from the place where the inspection and/or warranty work is performed. The purchaser shall be responsible for any damage or loss incurred in connection with the transportation of Power Train Components and/or part(s) of the Power Train Components submitted for inspection and/or warranty work.

D. Limitation of Damages and Implied Warranties

The foregoing EXPRESSED WARRANTY IS IN LIEU OF ALL OTHER EXPRESS WARRANTIES. Neither Tecumseh nor any of its affiliates makes any warranties, representations or promises, written or oral, as to the quality of the Power Train Component or any of its parts, other than as set forth herein.

ANY IMPLIED WARRANTY OF MERCHANTABILITY OR FITNESS FOR A PARTICULAR PURPOSE, TO THE EXTENT THAT EITHER MAY APPLY TO ANY PART(S) OF POWER TRAIN COMPONENTS, SHALL BE LIMITED IN DURATION TO THE PERIODS OF THE EXPRESSED WARRANTIES DEFINED IN PARAGRAPH A HEREOF. IN NO EVENT WILL TECUMSEH BE LIABLE FOR ANY INCIDENTAL, CONSEQUENTIAL OR SPECIAL DAMAGES AND/OR EXPENSES. Some states do not allow limitations on how long an implied warranty lasts or the exclusion or limitation of incidental or consequential damages, so the above limitation(s) or exclusion(s) may not apply to you. This warranty gives you specific legal rights and you may also have other legal rights which vary from state to state.

E. No Dealer Warranty

Tecumseh neither assumes nor authorizes any other person, natural or corporate, to assume for Tecumseh any other obligations or liabilities in connection with or with respect to any part(s) of a Power Train Component. The seller or dealer of part(s) of a Power Train Component has no authority, whatsoever, to make any representations or promises on behalf of Tecumseh or to modify the terms or limitations of Tecumseh's warranty in any way.