

REPAIR PARTS MANUAL
MODEL NO. BM155H107RB (96061003100)
Lawn Tractor

BESTGREEN

532 19 40-85 REV 1 10 18 04 RD
PRINTED IN U.S.A.

HOW TO USE THIS MANUAL

This manual is designed to provide the customer with a means to identify the parts on his/her tractor when ordering repair parts. The illustrations may or may not represent the actual assemblies; therefore, it is not recommended to use this manual as a guide to assemble or disassemble the tractor. Some hardware and parts are drawn larger in order to more readily identify them.

Each tractor has its own model number.

The model number for your tractor can be found on the fender under the seat.

When ordering parts, always give the following information:

- Product - "Tractor"
- Model Number - BM155H107RB (96061003100)
- Part Number
- Part Description

TABLE OF CONTENTS

SCHEMATIC	3
ELECTRICAL.....	4-5
CHASSIS.....	6-7
DRIVE.....	8-9
STEERING	10-11
SEAT	12
DECALS.....	13
ENGINE.....	14
MOWER LIFT	15
MOWER DECK	16-17
BAGGER.....	18-19

**TRACTOR MODEL NO. BM155H107RB (36061003100), PRODUCT NUMBER 360 61 00-31
SCHEMATIC**

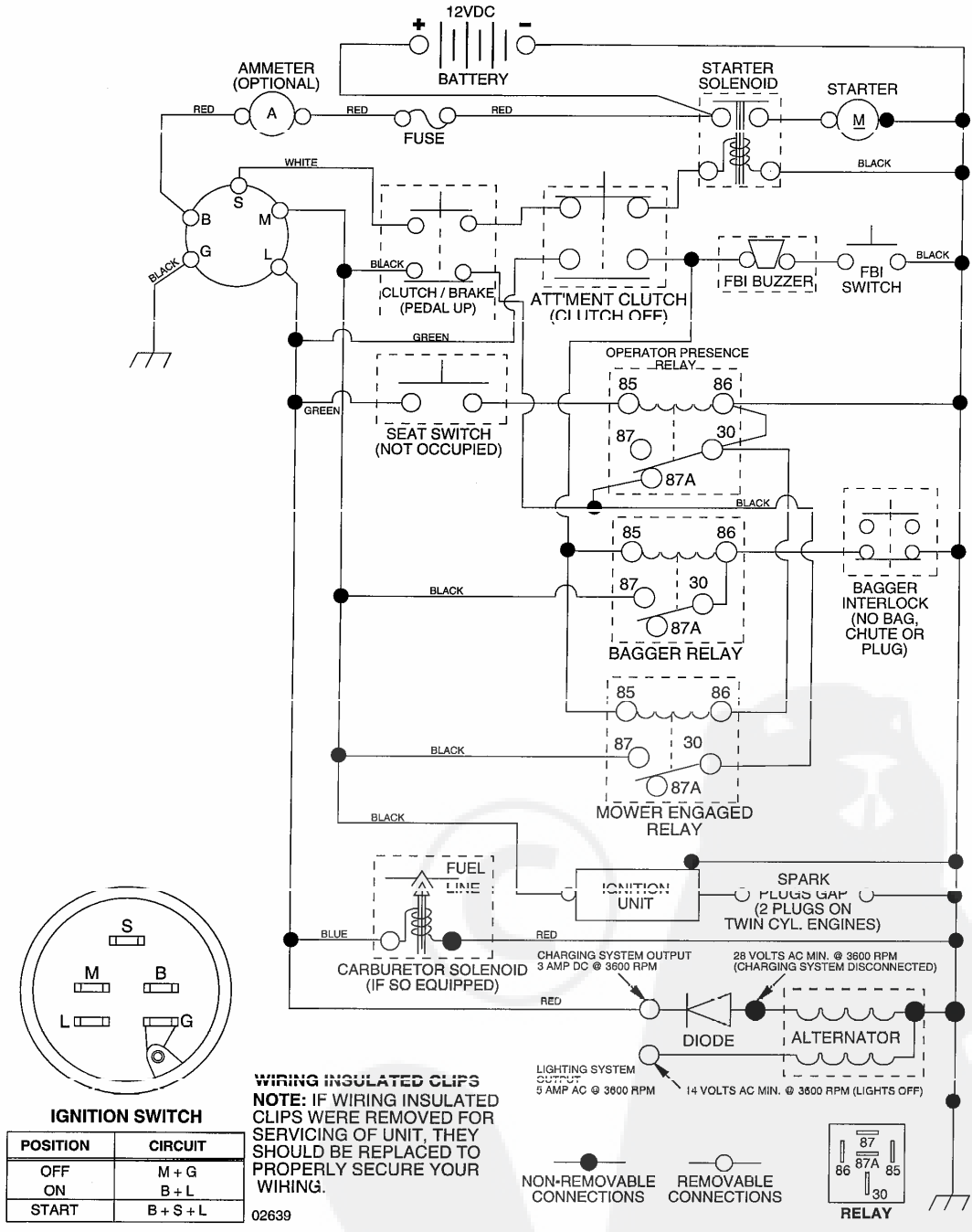

REPAIR PARTS

TRACTOR-MODEL NO. BM155H107RB (96061003100), PRODUCT NUMBER 960 61 00-31
ELECTRICAL

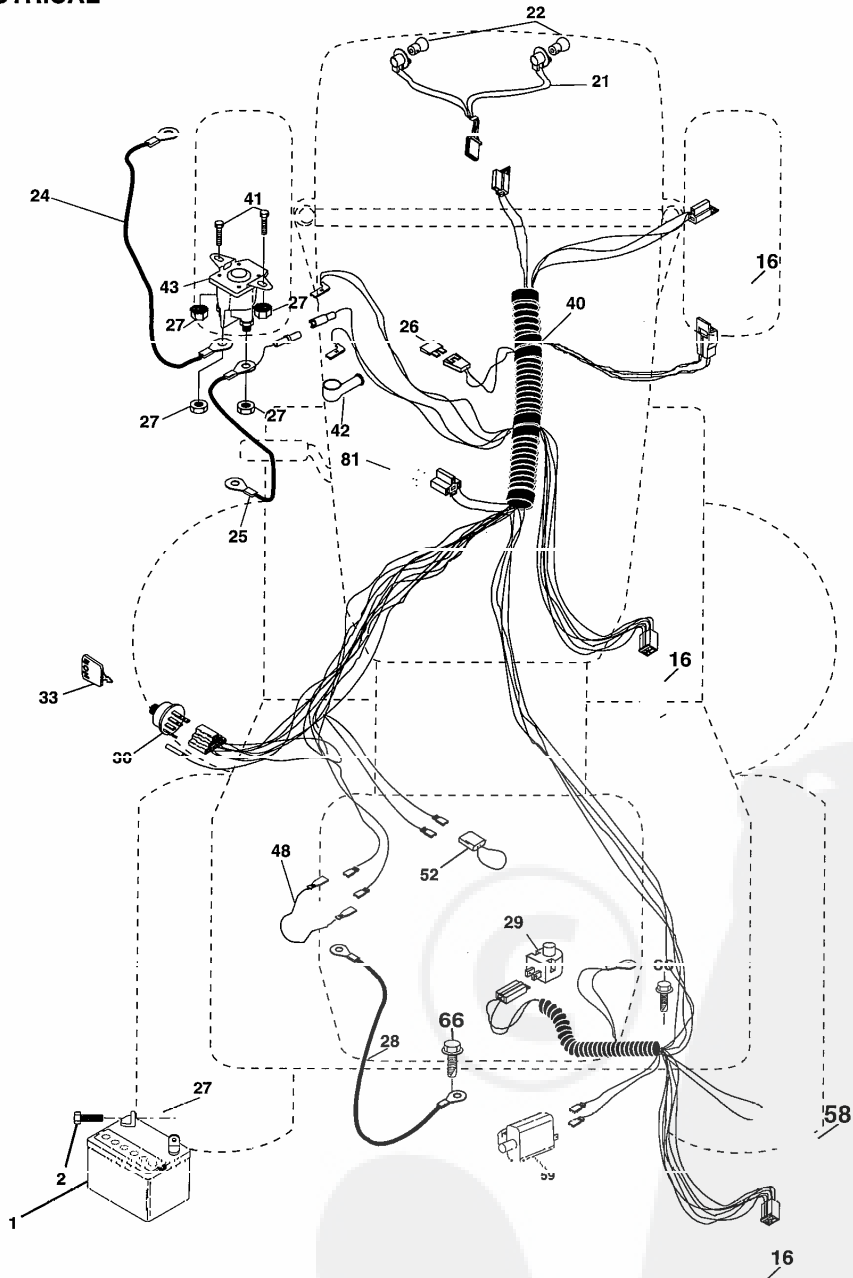

REPAIR PARTS

TRACTOR-MODEL NO. BM155H107RB (96061003100), PRODUCT NUMBER 960 61 00-31
ELECTRICAL

KEY NO.	PART NO.	DESCRIPTION
1	532 16 34-65	Battery
2	874 76 04-12	Bolt Hex Hd 1/4-20 unc x 3/4
16	532 17 61-38	Switch Interlock
21	532 18 37-59	Harness Asm Light W/4152J
22	532 00 41-52	Bulb Light #1156
24	532 12 47-80	Cable Starter 6 Ga. 11" Red
25	532 16 59-87	Cable Battery Crd 56" Red
26	532 17 51-58	Fuse
27	873 51 04-00	Nut Keps Hex 1/4-20 unc
28	532 12 77-25	Cable Ground 6 Ga. 18" Black
29	532 12 13-05	Switch Plunger Normal OP Gray
30	532 17 55-66	Switch Ignition
33	532 14 04-01	Key Ign
40	532 18 80-36	Harness Ign
41	871 11 04-08	Bolt Flk Fin Hex 1/4-20 unc x 1/2
42	532 13 15-63	Cover Terminal Red
43	532 17 88-61	Solenoid
48	532 14 08-44	Adapter, Ammeter
52	532 14 19-40	Protection Wire Loop
58	532 16 94-19	Buzzer Crd
59	532 18 03-79	Switch FBI CRD
66	817 49 06-08	Screw Thdrol 3/8-16 x 1/2 Ty-Tt
81	532 10 97-48	Relay Asm

NOTE: All component dimensions given in U.S. inches.
1 inch = 25.4 mm.

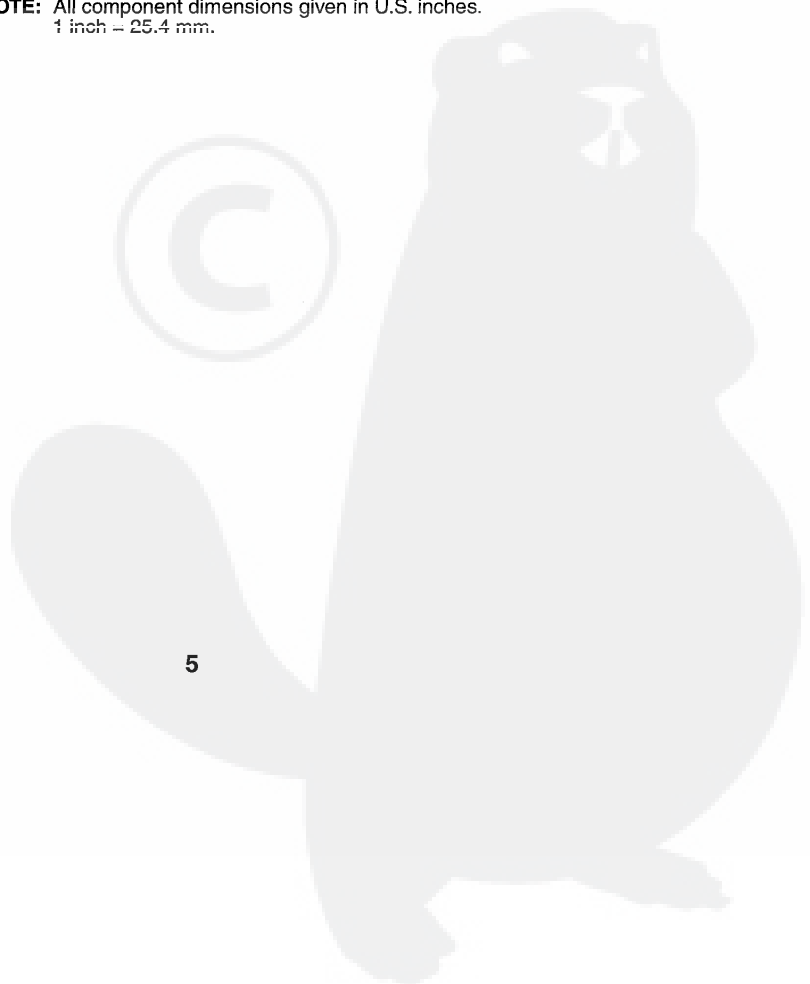
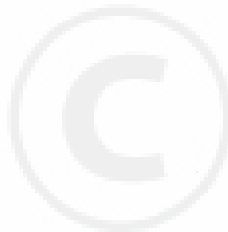

REPAIR PARTS

TRACTOR-MODEL NO. BM155H107RB (96061003100), PRODUCT NUMBER 960 61 00-31
CHASSIS AND ENCLOSURES

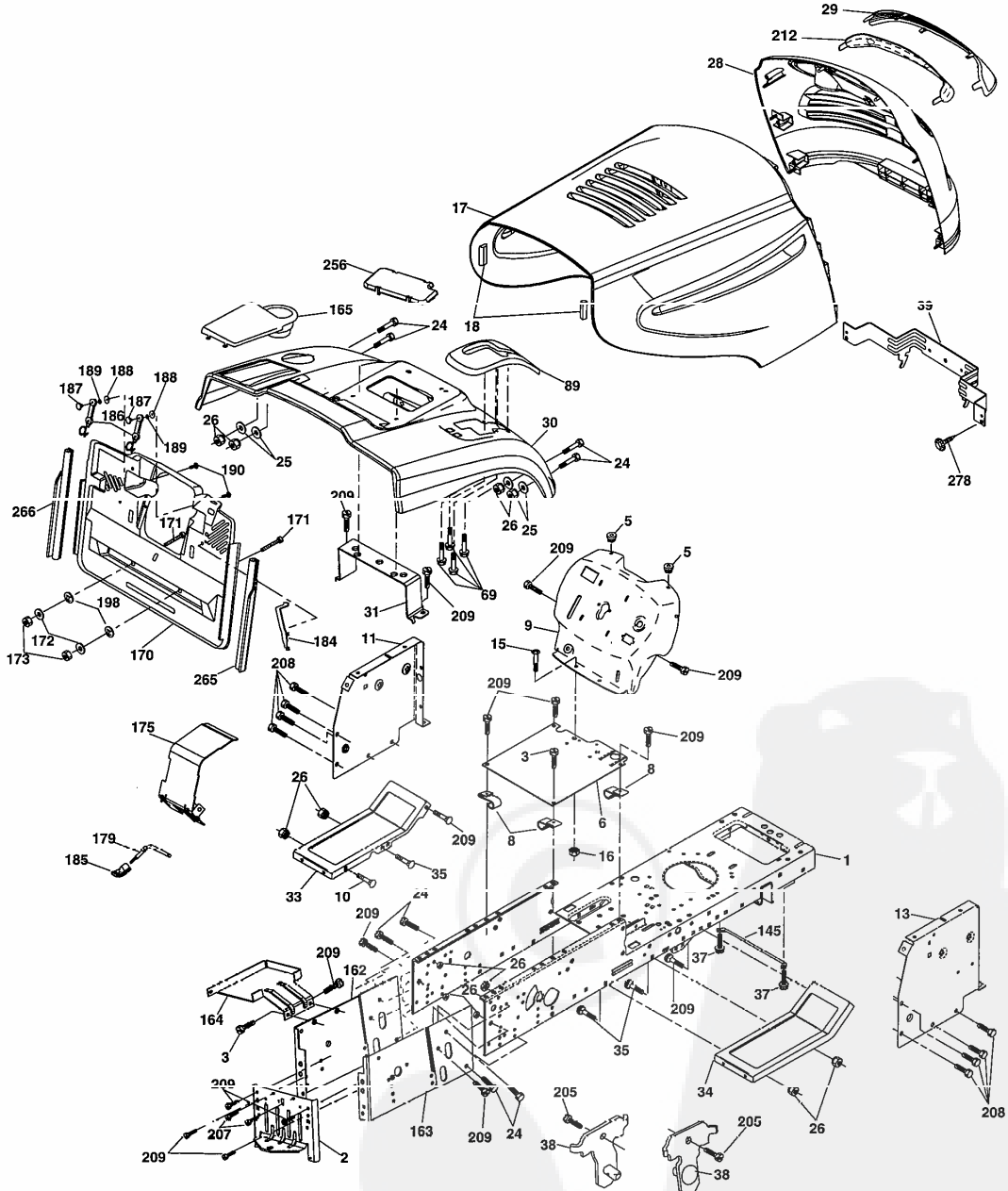

chassis-Elite_Basic_CRD_3

REPAIR PARTS

TRACTOR-MODEL NO. BM155H107RB (96061003100), PRODUCT NUMBER 960 61 00-31
CHASSIS AND ENCLOSURES

KEY NO.	PART NO.	DESCRIPTION
1	532 17 46-20	Chassis
2	532 18 03-84	Drawbar
3	817 06 06-12	Screw 3/8-16 x .75
5	532 15 52-72	Bumper Hood/Dash
6	532 18 44-19	Saddle
8	532 12 64-71	Clip Insulator 13/32 Mtg. Hole
9	532 19 46-88	Dash
10	872 14 06-08	Boit, Carriage 3/8-16 x 3/4
11	532 17 49-96	Panel, Dash, L.H.
13	532 18 69-52	Panel, Asm. Dash R.H.
15	874 18 05-12	Screw, Machine, Truss Head 5/16-18 unc x 3/4
16	873 51 05-00	Nut
17	532 19 24-37	Hood Assembly
18	532 12 69-38	Bumper Hood
24	874 78 06-16	Bolt
25	819 13 13-12	Washer 13/32 x 13/16 x 12 Ga.
26	873 80 06-00	Nut
28	532 18 38-26	Grille Lens Asm (Includes Key #'s 29, 212)
29	532 18 98-37	Lens Grille
30	532 19 24-69	Fender
31	532 16 51-56	Bracket, Fender Support
33	532 18 64-57	Footrest, L.H.
34	532 18 64-58	Footrest, R.H.
35	872 11 06-06	Bolt
37	817 49 05-08	Screw Thdrol 5/16-18 x 1/2 TYT
38	532 18 17-48	Bracket Asm Pivot Mower Rear
39	532 17 47-14	Bracket Pivot
58	532 15 01-27	Duct Air Engine PI/Lt
69	532 14 24-32	Screw Hex 1/4-1/2
89	532 18 13-60	Console
145	532 15 65-24	Rod Pivot Chassis/Hood

KEY NO.	PART NO.	DESCRIPTION
162	532 18 03-82	Bracket Exten Chassis Lh CRD
163	532 18 03-83	Bracket Exten Chassis Rh CRD
164	532 16 56-05	Support Battery CRD
165	532 18 13-56	Cover Battery CRD
170	532 17 88-62	Backplate CRD
171	872 14 06-20	Bolt Rdhd Sqnk 3/8-16 x 2-1/2 G5
172	819 13 20-16	Washer 13/32 x 1-1/4 x 16 Ga.
173	873 51 06-00	Nut, Keys Hex 3/8-16 UNC
175	532 18 82-03	Trap Door CRD
179	532 18 82-02	Rod Pivot FBI CRD
184	532 17 46-62	Bracket Actuator Bagger CRD
185	532 18 11-01	Knob Rod
186	532 16 07-93	Latch Asm Multch Bagger
187	532 12 50-04	Nut Weld .327/.304 #10-24
188	819 06 12-16	Washer #10
189	810 07 10-00	Washer Lock #10
190	871 08 10-10	Screw Pan Hd Phillips 10-24 x 5/8
198	532 16 89-37	Nut Push
205	817 49 06-08	Screw 3/8-16 x 1/2
207	817 67 05-08	Screw 5/16-18 x 1/2
208	817 67 06-08	Screw Thdrol 3/8-16 x 1/2
209	817 00 06-12	Screw Hex Wsh Thdrol 3/8-16 x 3/4
212	532 18 98-37	Lens Grille
256	532 18 13-61	Cover Fender Rack CRD
265	532 18 57-04	Seal, Side RH
266	532 18 57-03	Seal, Side LH
--	532 00 54-73	Plug, Button
--	532 19 39-35	Plug Switch Light

NOTE: All component dimensions given in U.S. inches.
1 inch = 25.4 mm.

REPAIR PARTS

TRACTOR-MODEL NO. BM155H107RB (96061003100), PRODUCT NUMBER 960 61 00-31
DRIVE

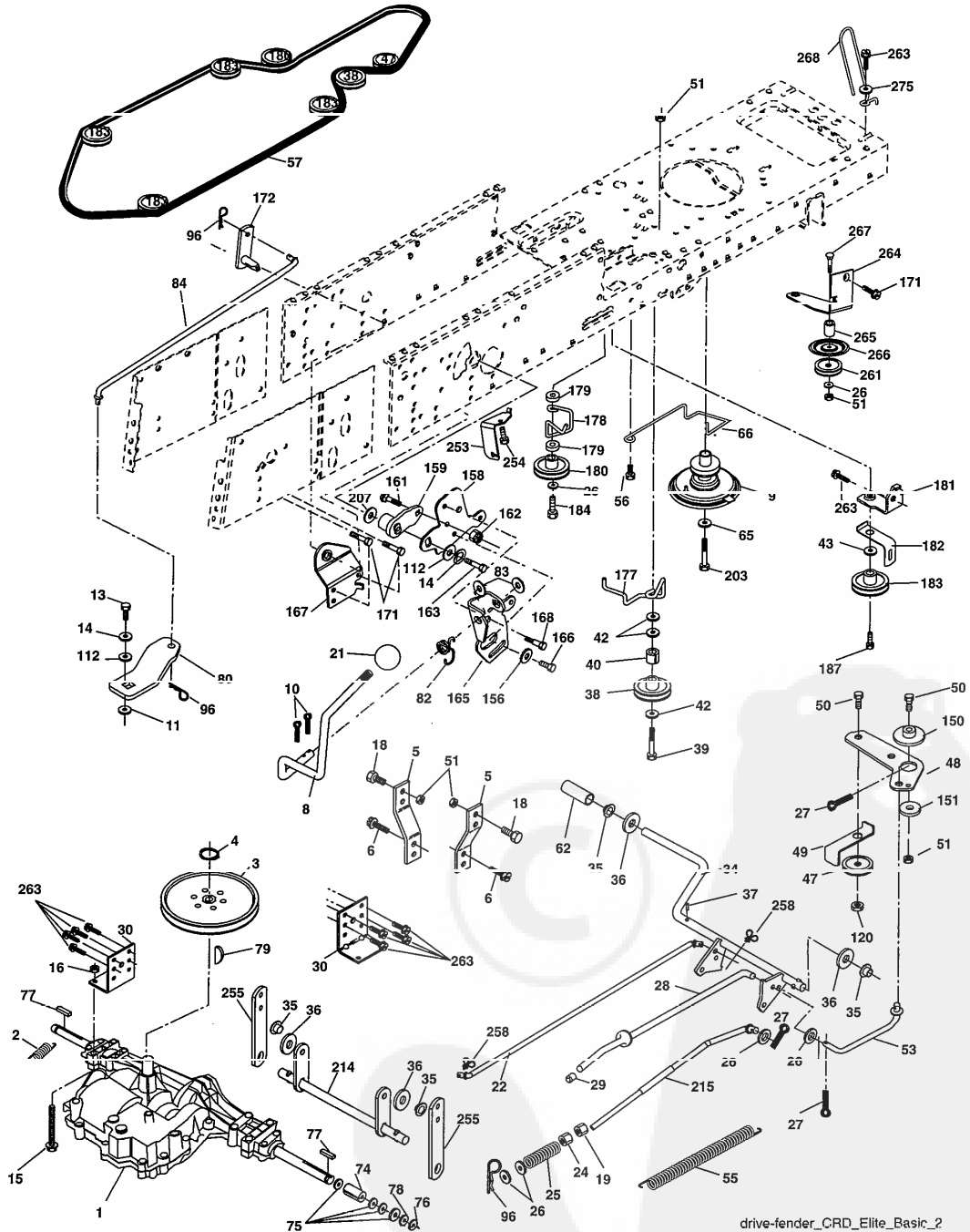

drive-fender_CRD_Elite_Basic_2

REPAIR PARTS

TRACTOR-MODEL NO. BM155H107RB (96061003100), PRODUCT NUMBER 960 61 00-31
DRIVE

KEY NO.	PART NO.	DESCRIPTION	KEY NO.	PART NO.	DESCRIPTION
1	-----	Transaxle Hydro Gear 321-0510 (Order parts from transaxle manufacturer)	96	532 12 47-88	Spring, Retainer 1"
8	532 16 56-19	Rod, Shift Fender Adjust Lt	112	819 09 12-10	Washer 9/32 x 3/4 x 10 Ga.
9	532 18 03-54	Clutch	120	873 90 06-00	Nut Lock Flg. 3/8-16 Unc
10	876 02 04-16	Pin, Cotter 1/8 x 1	150	532 16 58-50	Bushing, Bellcrank Grnd Dr
14	810 04 04-00	Washer, Lock Hvy Helical	151	819 13 32-10	Washer 13/32 x 2 x 10 Ga.
15	874 49 05-44	Bolt Hex FGHD 5/16-18 x Gr 5	156	532 16 60-02	Washer Srrtd 5/16ID x 1.125
16	873 80 05-00	Nut, Lock Hex w/Ins 5/16-18 Unc	158	532 16 55-89	Bracket Shift Mount
19	873 80 06-00	Nut, Lock Hex w/Ins. 3/8-16	159	532 18 39-00	Hub Shift
21	532 10 69-33	Knob	160	819 29 20-16	Washer 29/32 x 1-1/4 x 16 Ga.
22	532 17 56-07	Rod, Brake	161	872 14 04-06	Bolt Rdhd Sqnk 1/4-20 x 3/4 Gr 5
24	873 35 06-00	Nut	162	873 68 04-00	Nut Crownlock 1/4-20 Unc
25	532 10 68-88	Spring, Rod, Brake	163	874 78 04-16	Bolt Hex Fin 1/4-20 Unc x 1 Gr 5
26	819 13 13-16	Washer 13/32 x 13/16 x 16 Ga.	165	532 16 56-23	Bracket Pivot Lever
27	876 02 04-12	Pin, Cotter 1/8 x 3/4	166	817 49 05-10	Screw 5/16-18 x 5/8
28	532 17 57-65	Rod, Parking Brake	167	532 16 55-88	Bracket Support Shift CRD
29	532 07 16-73	Cap, Parking Brake	168	532 16 54-92	Bolt Shoulder 5/16-18 x .561
30	532 16 95-92	Bracket, Mfg. Transaxle	169	532 16 55-80	Plate Fastening Lt
34	532 17 55-78	Shaft, Asm Pedal Foot CRD	171	817 49 06-08	Screw Thdrol 3/8-16 x 1/2 Ty-Tt
35	532 12 01-83	Bearing, Nylon	172	532 17 02-71	Shaft Asm Shifter Frt CRD
36	819 21 16-16	Washer 21/32 x 1 x 16 Ga.	177	532 16 59-22	Keeper Flat Idler 2.06" CRD
37	532 12 49-63	Pin, Roll 3/16 x 1"	178	532 16 59-33	Keeper Belt Idler 1.88" CRD
38	532 16 59-36	Pulley Flat Composite 3.06"	179	532 12 09-58	Washer Sintered
39	874 76 06-44	Bolt Fin Hex 3/8-16 Unc x 2-3/4	180	532 16 56-30	Pulley, Idler, Flat 1.88"CRD
40	532 12 49-65	Spacer, Split 395 x 59 Bzp	181	532 18 02-11	Bracket Idler Ground Drive CRD
42	819 13 13-12	Washer 13/32 x 13/16 x 12 Ga.	182	532 18 26-82	Keeper Belt 2.5" Od V-Idler CRD
43	819 11 10-12	Washer 11/32 x 5/8 x 12 Ga	183	532 18 60-07	Pulley V-Idler 2.50" Od CRD
47	532 12 77-83	Pulley, Idler, V Groove Plasitc	184	817 49 06-44	Screw Hexwsh Thdrol 3/8-16 x 2-3/4
48	532 15 44-07	Bellcrank Clutch, Grnd Drv	185	532 17 00-08	Link Shift
49	532 12 32-05	Retainer, Belt Style Spring	186	532 16 56-14	Hub Tapered Round CRD
50	872 11 06-12	Bolt, Carr. 3/8-16 x 1/2 x Gr. 5	187	817 58 05-20	Screw Thdrol 5/16-18 x 1.25
51	873 68 06-00	Nut, Crownlock 3/8-16 Unc	197	532 16 96-13	Nyliner Snap-In 5/8
52	873 68 05-00	Nut Crownlock 5/16-18	199	532 16 96-12	Bolt Shoulder 5/16-18 Unc
53	532 10 57-10	Link, Clutch 7.66	200	872 14 05-08	Bolt RDHD SQNK 5/16-18 x 1
55	532 10 57-09	Spring, Return, Clutch	203	871 17 07-80	Bolt Hex 7/16-20 x 5
56	817 06 06-20	Screw 3/8-16 x 1-1/4	207	532 16 98-45	Washer Nylon Rear
57	532 17 01-40	V-Belt Key 112" 0650 CRD	214	532 17 56-09	Shaft Asm. Brake
62	532 12 48-72	Cover, Pedal	215	532 17 56-52	Rod Brake Hydro
65	810 04 07-00	Washer	253	532 17 50-28	Bracket, Cable
66	532 15 47-78	Keeper, Belt Engine F-Proof	254	817 00 06-16	Screw 3/8-16 x 1
71	532 16 91-82	Strap, Torque, Rh	255	532 17 56-08	Brace Shaft Brake Mtg.
73	532 16 91-83	Strap, Torque, Lh	258	532 17 80-62	Clip Retainer
74	532 13 70-57	Spacer, Split	259	532 18 02-12	Bracket Pulley
75	532 12 17-49	Washer 25/32 x 1-1/4 x 16 Ga.	261	532 13 14-94	Pulley Idler Flat
76	812 00 00-01	Ring, E	263	817 00 06-12	Screw 3/8-16 x 3/4
77	532 12 35-83	Key, Square	264	532 18 19-95	Bracket Clutch
78	532 12 17-48	Washer 25/32 x 1-5/8 x 16 Ga.	265	532 18 20-13	Spacer, Idler
81	532 17 00-06	Asm. Shaft	266	532 18 20-61	Shield, Idler
82	532 16 57-11	Spring, Torsion	267	872 14 06-26	Bolt Carr. 3/8-16 x 3-1/4
83	819 17 12-16	Washer 17/32 x 3/4 x 16 Ga.	268	532 18 24-02	Guard Muffler
84	532 17 00-07	Link, Transaxle	275	819 13 16-14	Washer 13/32 x 1 x 14 Ga.
95	532 17 00-15	Control Asm Bypass Hydro			

NOTE: All component dimensions given in U.S. inches
1 inch = 25.4 mm

REPAIR PARTS

TRACTOR-MODEL NO. BM155H107RB (96061003100), PRODUCT NUMBER 960 61 00-31
STEERING ASSEMBLY

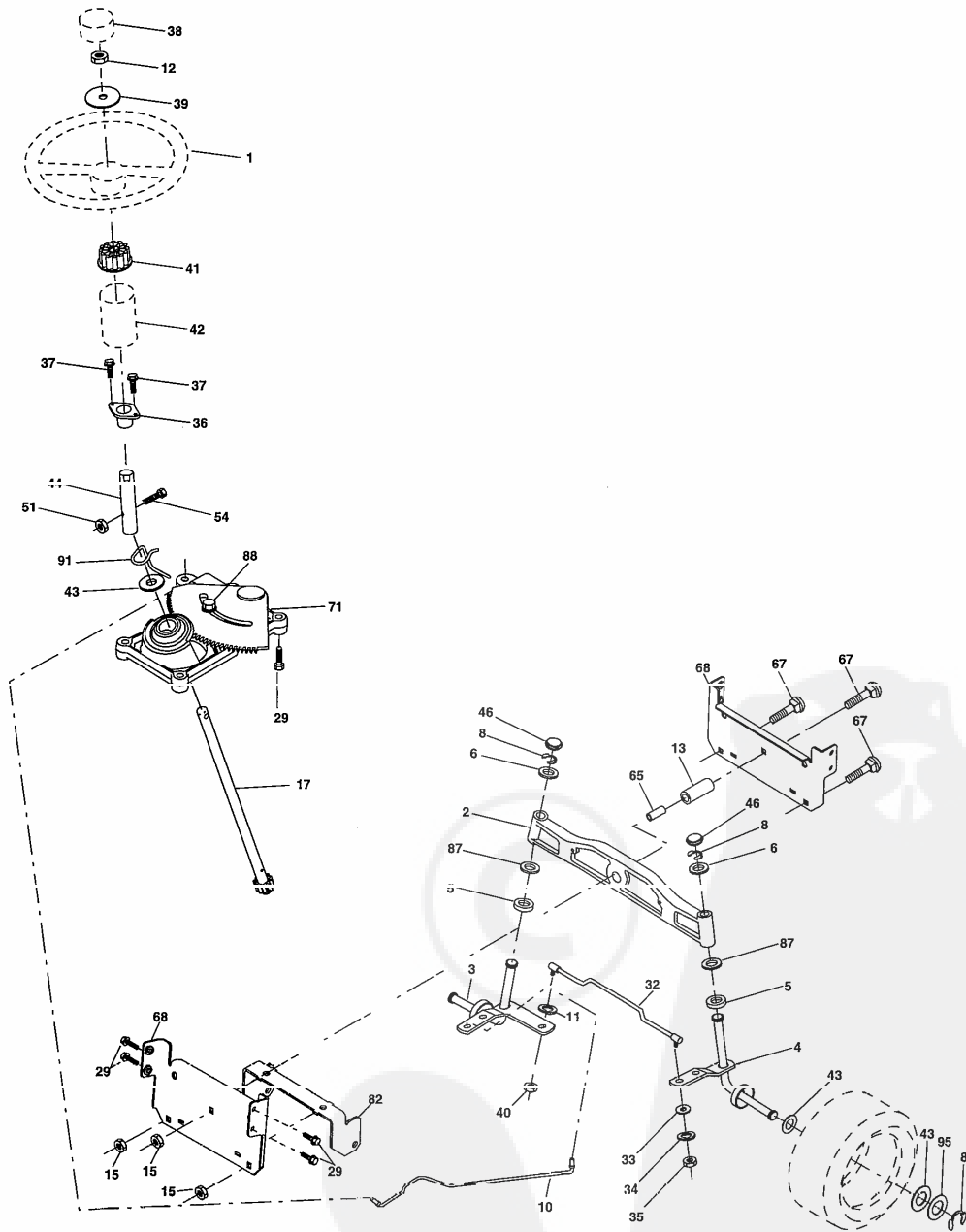

steering_pl.lt_29

REPAIR PARTS

TRACTOR-MODEL NO. BM155H107RB (96061003100), PRODUCT NUMBER 960 61 00-31
STEERING ASSEMBLY

KEY NO.	PART NO.	DESCRIPTION
1	532 19 45-95	Steering Wheel
2	532 18 47-06	Axle Assembly
3	532 16 98-40	Spindle Assembly, L.H.
4	532 16 98-39	Spindle Assembly, R.H.
5	532 12 49-31	Bearing, Race, Thrust, Hardened
6	532 12 17-48	Washer 25/32 x 1-5/8 x 16 Ga.
8	812 00 00-29	Ring, Klip
10	532 17 51-21	Link, Drag
11	810 04 06-00	Washer, Lock
12	873 94 08-00	Nut Hex Jam Toplock 1/2-20 unf
13	532 13 65-18	Spacer Brg Axle Front
15	532 14 52-12	Nut, Hexflange Lock
17	532 18 06-41	Shaft Assembly, Steering
29	817 00 06-12	Screw, 3/8-16 x 3/4
32	532 17 01-62	Rod, Tie
33	819 11 12-16	Washer 11/32 x 3/4 x 16 Ga.
34	810 04 05-00	Washer Lock Hvy Hlcl Spr 5/16
35	873 54 05-00	Nut Crownlock 5/16-24 unf
36	532 15 50-99	Bushing, Steering
37	532 15 29-27	Screw TT #10-32 x 5 x 3/8 Flange
38	532 19 46-03	Cap Wheel Steering
39	819 18 38-12	Washer 9/16 x 2 3/8 x 12 Ga.
40	873 54 06-00	Nut Crownlock 3/8-24
41	532 18 67-37	Adaptor, Steering Wheel
42	532 16 96-33	Boot, Steering Dash P/L Mtl
43	532 12 17-49	Washer 25/32 x 1-1/4 x 16 Ga.
44	532 18 06-40	Extension Steering
46	532 12 12-32	Cap, Spindle
51	873 54 04-00	Nut Crownlock 1unf x 1 1/4
65	532 16 03-67	Spacer Brace Axle
67	872 11 06-18	Bolt Rdhd Sq 3/8-16 unc x 2-1/4
71	532 17 51-46	Steering Asm.
68	532 16 98-27	Brace Axle
82	532 16 98-35	Bracket Susp Chassis Front
87	532 17 39-66	Washer Flat .781 x 1-1/2 x .14
88	532 17 51-18	Bolt Shoulder 7/16-20 Unc
91	532 17 55-55	Clip Steering
95	532 18 89-67	Washer Hardened

NOTE: All component dimensions given in U.S. inches.
1 inch = 25.4 mm.

REPAIR PARTS

TRACTOR-MODEL NO. BM155H107RB (96061003100), PRODUCT NUMBER 960 61 00-31
SEAT ASSEMBLY

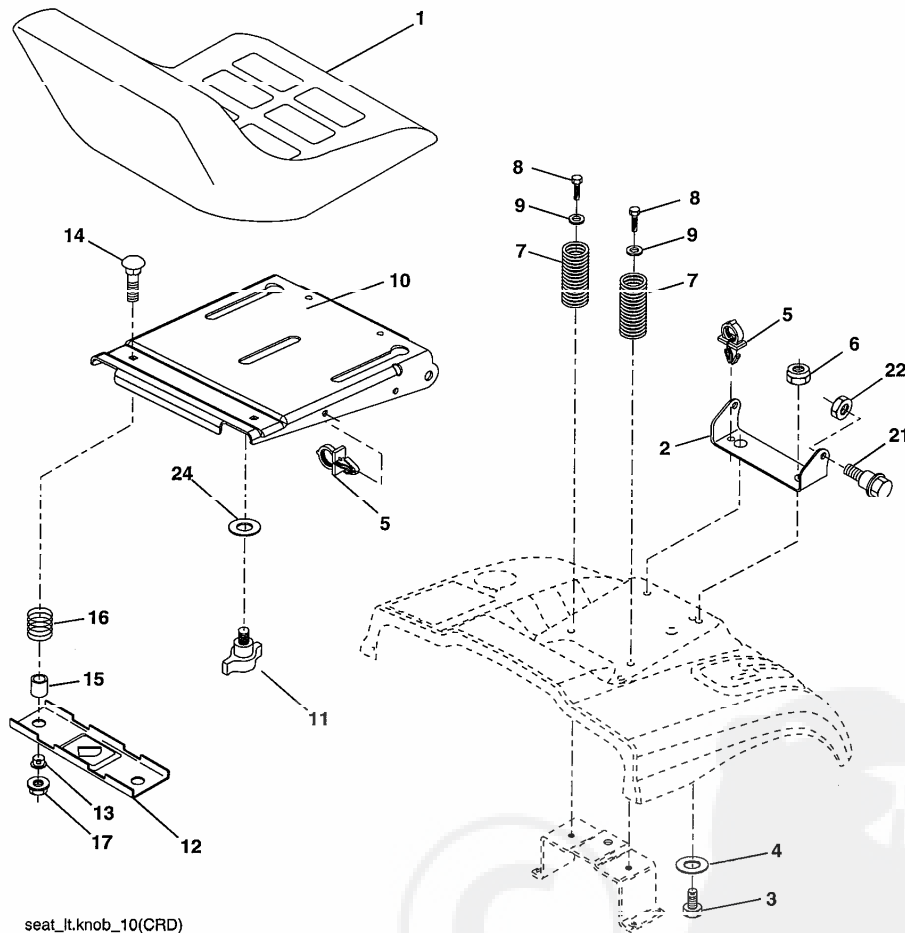

seat_lt.knob_10(CRD)

KEY NO.	PART NO.	DESCRIPTION
1	532 18 87-06	Seat
2	532 18 01-66	Bracket Pnt Pivot Seat (blk)
3	871 11 06-16	Bolt Fin Hex 3/8-16 Unc x 1
4	819 13 16-10	Washer Flat 13/32 x 1 x 10 Ga.
5	532 14 50-06	Clip Push In Hinged
6	873 80 06-00	Nut Lock Hex 3/8-16 Unc
7	532 12 41-81	Spring Seat Cprsn 2 250 Blk Zi
8	817 00 06-16	Screw 3/8-16 X 1-1/2
9	819 13 16-14	Washer 13/32 X 1 X 14 Ga
10	532 18 01-86	Pan Pnt Seat (blk)
11	532 16 63-69	Knob Seat Adj Wingnut
12	532 12 12-46	Bracket Pnt Mounting Switch

KEY NO.	PART NO.	DESCRIPTION
13	532 12 12-48	Bushing Snap Blk Nyl 50 Id
14	872 05 04-12	Bolt Rdhd Sht Nk 1/4-20x1-1/2
15	532 12 12-49	Spacer Split
16	532 12 37-40	Spring Cprsn
17	532 12 39-76	Nut Lock 1/4 Lge Flg Gr 5 Zinc
21	532 17 18-52	Bolt Shoulder 5/16-18 Unc-2A
22	873 80 05-00	Nut Hex Lock w/Ins 5/16-18
24	819 17 19-12	Washer 17/32 X 1-3/16 X 12 Ga.

NOTE: All component dimensions given in U.S. inches.
1 inch = 25.4 mm

REPAIR PARTS

TRACTOR-MODEL NO. BM155H107RB (96061003100), PRODUCT NUMBER 960 61 00-31
DECALS

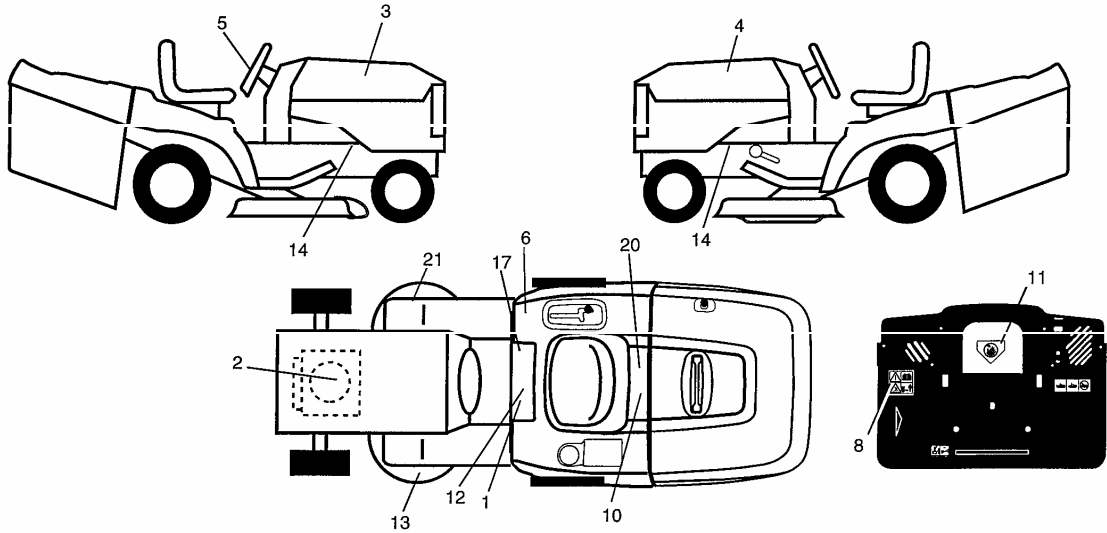

KEY NO.	PART NO.	DESCRIPTION
1	532 14 54-98	Decal Read Owner's Manual Sym
2	532 18 47-69	Decal Engine
3	532 19 44-22	Decal Hood RH
4	532 19 44-23	Decal Hood LH
5	532 19 44-19	Decal Steering Wheel
6	532 18 04-32	Decal 100 DBA/CE
9	532 19 04 35	Decal Rear Plate
10	532 14 50-05	Decal Bat Dan/Poi P/L Sym Wpn
11	532 18 21-66	Decal Mower Cut Finger Symbol
12	532 15 97-37	Decal Brake/Clutch Symbol Lt
13	532 18 78-11	Decal Enviro
14	532 15 97-36	Decal Chassis Hot Muffler

KEY NO.	PART NO.	DESCRIPTION
17	532 14 08-37	Decal Saddle Brake Parking
20	532 16 69-60	Decal Bypass Fender CRD
21	532 16 62-86	Decal Hex Belt Sch
—	532 13 83-11	Decal Lift Handle
—	532 18 10-90	Pad Footrest RH
—	532 18 10-91	Pad Footrest LH
—	532 19 26-21	Decal Bagger Frame
—	532 19 40-82	Manual Operator's (Euro)
—	532 19 40-83	Manual Operator's (Port)
—	532 19 40-84	Manual Operator's (Polish)
—	532 19 40-85	Manual Parts

WHEELS & TIRES

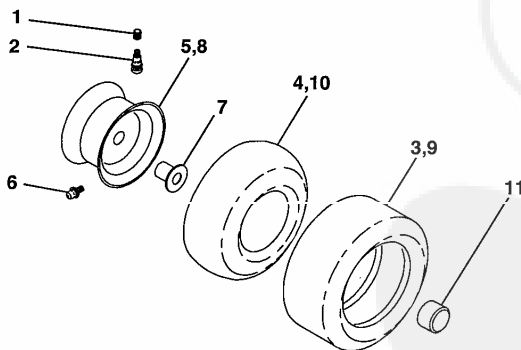

KEY NO.	PART NO.	DESCRIPTION
1	532 05 91-92	Cap Valve Tire
2	532 06 51-39	Stem Valve
3	532 10 62-22	Tire F Ts 15 X 6 0 - 6 Service
4	532 05 99-04	Tube Inner Front #35060
5	532 13 83-36	Rim Asm 6" front Service
6	532 12 49-57	Fitting Grease
7	532 12 49-59	Bearing Flange
8	532 13 83-37	Rim Asm 8" rear Service
9	532 13 84-68	Tire R Ts 20 x 6-6 Service
10	532 12 49-26	Tube Rear 9 5 X 8 Service
11	532 17 50-39	Cap Axle Blk 1 50 X 1 00
--	532 14 43-34	Sealant, Tire (10 oz. tube)

NOTE: All component dimensions given in U.S. inches
1 inch = 25.4 mm

REPAIR PARTS

TRACTOR-MODEL NO. BM155H107RB (96061003100), PRODUCT NUMBER 960 61 00-31
ENGINE

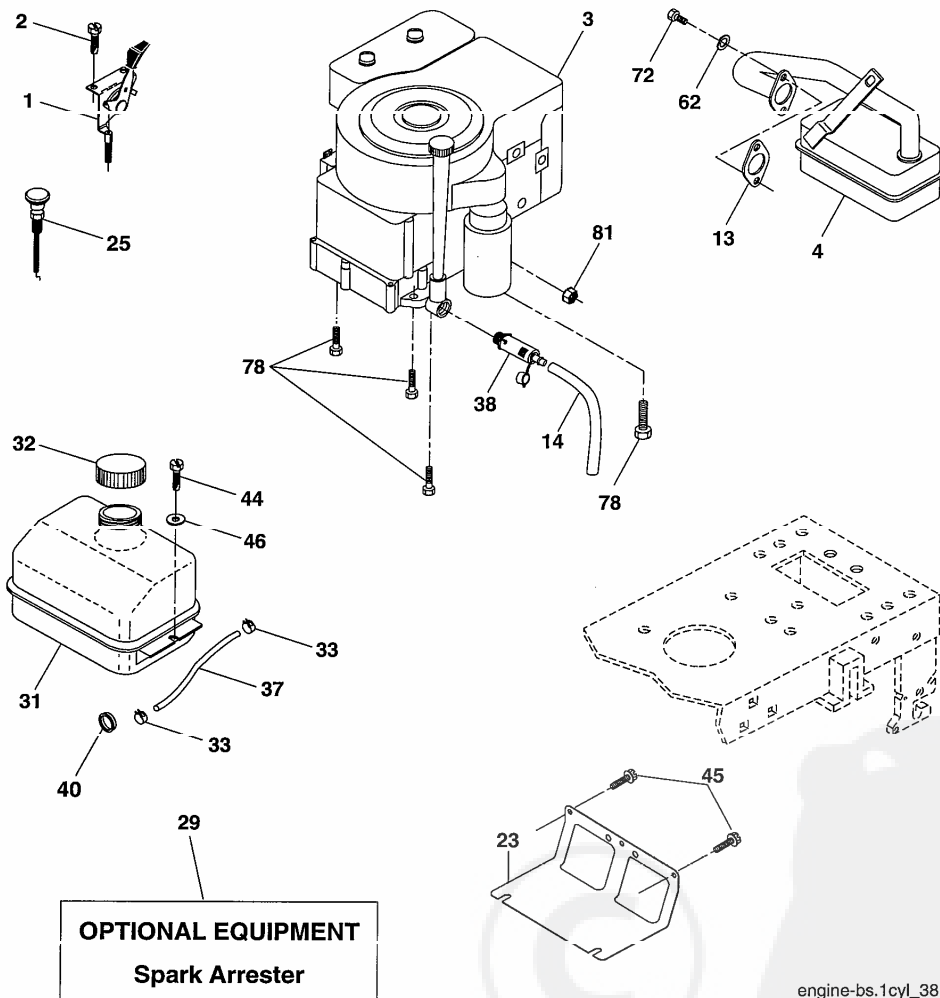

OPTIONAL EQUIPMENT
Spark Arrester

engine-bs.1cyl_38

KEY NO.	PART NO.	DESCRIPTION
1	532 17 05-51	Control Throt Flag
2	817 72 04-08	Screw Hex Thd Cut 1/4-20x1/2
3	-----	Engine B&S Model 282H07 (Order parts from engine manufacturer)
4	532 13 73-52	Muffler Exhaust
13	532 16 52-91	Gasket Muffler
14	532 14 84-56	Tube Drain Oil Easy
23	532 16 98-37	Shield BRN/DBR Guard
25	532 19 06-95	Control Choke
26	873 92 06-00	Nut Keps 3/8-24 unf
29	532 13 71-80	Arrestor Spark
31	532 18 77-50	Tank Fuel Front

KEY NO.	PART NO.	DESCRIPTION
32	532 14 05-27	Cap Fuel Asm Top Vent
33	532 12 34-87	Clamp Hose Blk
37	532 13 70-40	Line Fuel
38	532 16 16-54	Plug Drain Oil Easy
40	532 12 40-28	Bushing
44	817 67 04-12	Screw Hexwsh Thdrol 1/4-20 x 3/4
45	817 00 06-12	Screw 3/8-16 x 3/4
46	819 09 14-16	Washer 9/32 X 7/8 x 16ga
72	532 18 39-06	Screw, Socket 5/16-18 x 1
78	817 06 06-20	Screw 3/8-1/6 x 1-1/4
81	873 51 04-00	Nut Keps 1/4-20 Unc

NOTE: All component dimensions given in U.S. inches
1 inch = 25.4 mm

REPAIR PARTS

TRACTOR-MODEL NO. BM155H107RB (96061003100), PRODUCT NUMBER 960 61 00-31
MOWER LIFT

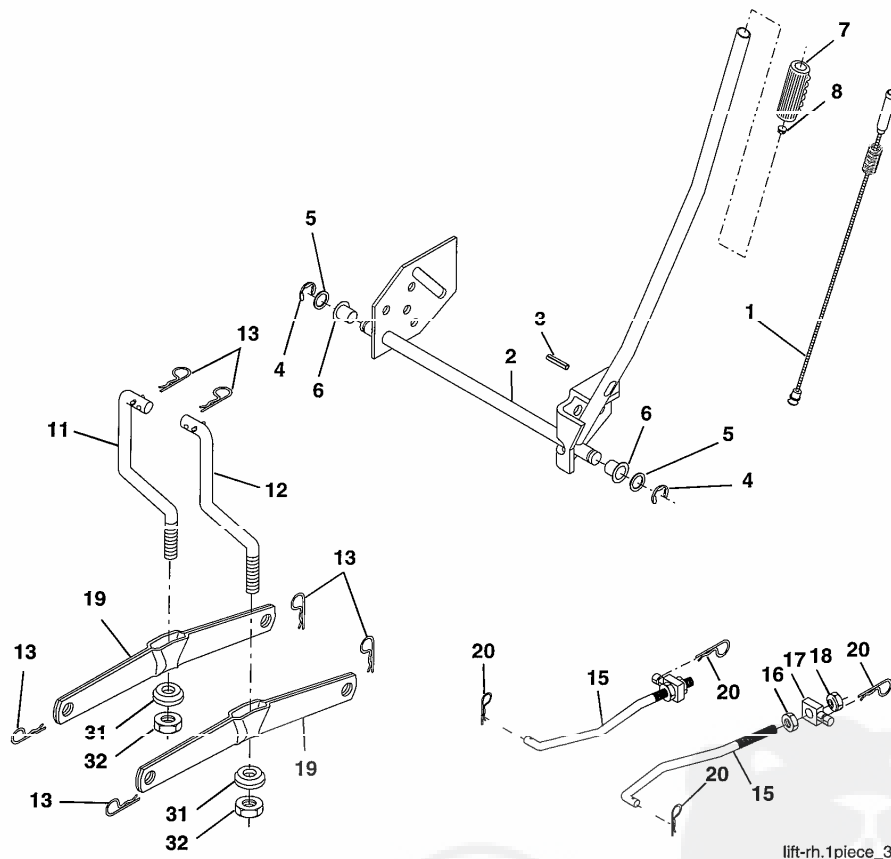

KEY NO.	PART NO.	DESCRIPTION
1	532 15 94-61	Washer Asm Inner Spring W/ Plunger
2	532 15 94-76	Shaft Asm. Lift
3	532 18 88-22	Pin Groove
4	812 00 00-02	E Ring #5133-62
5	819 21 16-21	Washer 21/32 x 1 x 21 Ga.
6	532 12 01-83	Bearing Nylon
7	532 10 94-13	Grip Handle
8	532 12 45-26	Button Plunger
11	532 16 58-29	Link Asm Lift L.H.
12	532 16 58-31	Link Asm Lift R.H.
13	532 00 49-39	Retainer Spring

KEY NO.	PART NO.	DESCRIPTION
15	532 17 32-88	Link Front
16	873 35 08-00	Nut Jam Hex 1/2-13 Unc
17	532 17 56-89	Trunnion Blk Zinc
18	873 80 08-00	Nut Lock w/wsh 1/2-13 Unc
19	532 13 98-68	Arm Suspension Mower
20	532 16 35-52	Retainer Spring
31	532 16 98-65	Bearing, Pvt. Lift.
32	873 54 06-00	Nut Crownlock 3/8-24

NOTE: All component dimensions given in U.S. inches
1 inch = 25.4 mm

REPAIR PARTS

TRACTOR-MODEL NO. BM155H107RB (96061003100), PRODUCT NUMBER 960 61 00-31
MOWER

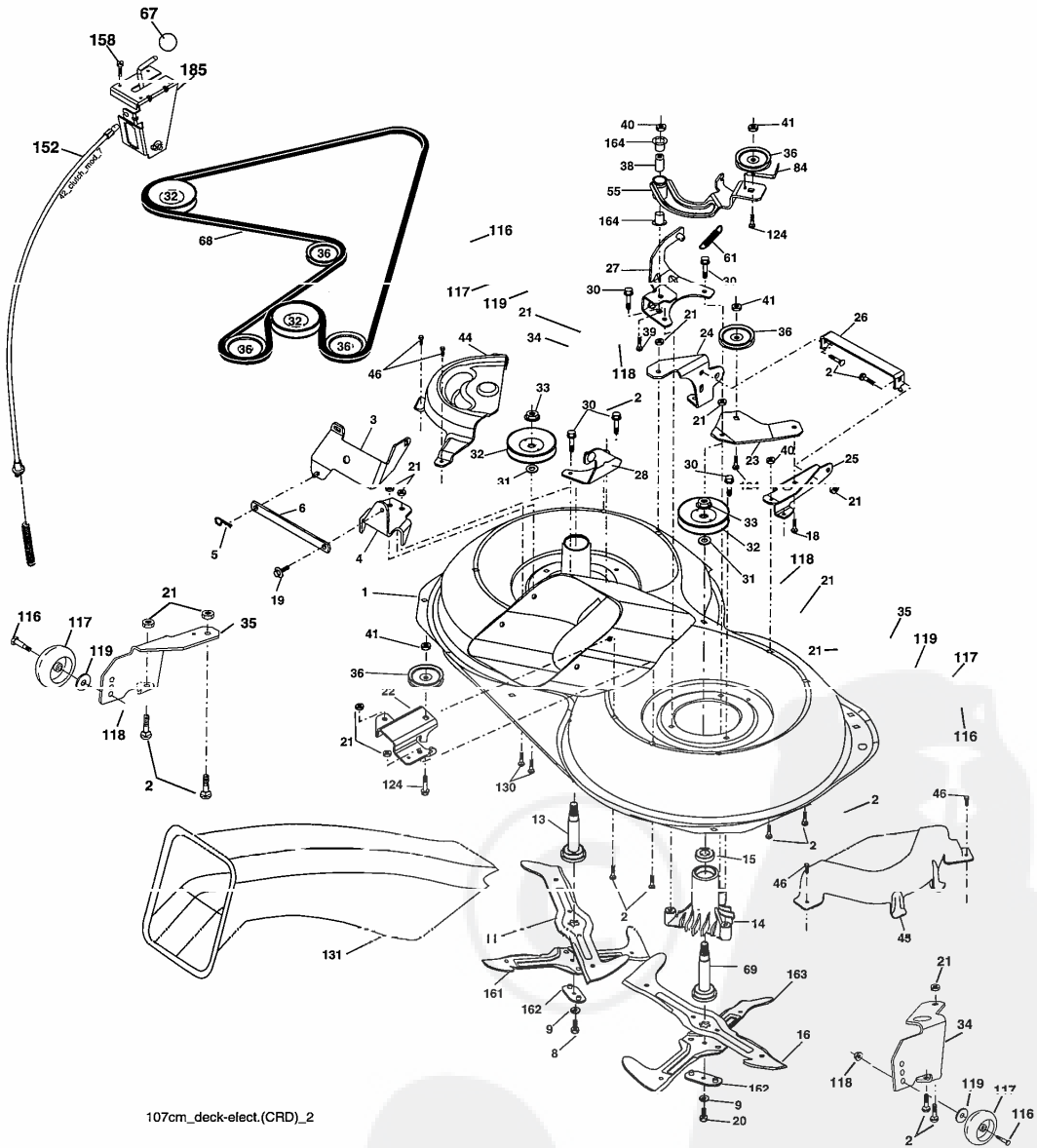

REPAIR PARTS

TRACTOR-MODEL NO. BM155H107RB (96061003100), PRODUCT NUMBER 960 61 00-31
MOWER

KEY NO.	PART NO.	DESCRIPTION	KEY NO.	PART NO.	DESCRIPTION
1	532 16 91-60	Housing Asm. Mower	40	873 68 06-00	Nut Crownlock 3/8-16 unc
2	872 14 05-06	Bolt Rdhd Sqnk 5/16-18 unc x 3/4	41	873 90 06-00	Nut Flangelock 3/8-16 unc
3	532 16 55-69	Bracket Asm. S-Bar Chass	44	532 17 55-38	Cover Mandrel Lh
4	532 16 91-67	Bracket Bar Sway Deck	45	532 17 55-39	Cover Mandrel Rh
5	532 12 46-70	Retainer Spring	46	532 13 77-29	Screw Thd Roll 1/4-20 x 5/8
6	532 16 55-57	Bar Sway	55	532 16 98-49	Arm Idler 107 CRD
8	532 18 17-12	Bolt 3/8-24 x 1.25 Gr. 8 Ptch Lhthd	61	532 17 51-59	Spring Tension Belt
9	810 03 06-00	Washer Lock Hvy 3/8 Unplated	67	532 10 69-32	Knob
11	532 18 05-83	Blade 3-1 Lh	68	532 16 91-78	Hex-Belt Mower
13	532 13 76-45	Shaft Asm. W/Lower Bearing	69	532 16 54-82	Shaft Asm W/Lwr Brg Rh Thd CRD
14	532 12 87-74	Housing Mandrel Vented (Machd)	84	532 15 60-85	Keeper Belt Idler
15	532 11 04-85	Bearing Ball Mandrel	116	532 18 42-19	Bolt Shoulder
16	532 18 05-84	Blade 3-1 Rh	117	532 13 39-57	Wheel Gage Donut Wide
18	872 11 06-06	Bolt Rdhd Sht Sqnk 3/8-16 x 3/4	118	873 93 06-00	Nut Centerlock 3/8-16 unc
19	532 13 28-27	Bolt Shoulder 5/16-18 Thd Form	119	819 12 14-14	Washer 3/8 x 7/8 x 14 Ga.
20	532 18 17-13	Bolt 3/8-24 x 1.25 Gr. 8 Patched	124	872 11 06-12	Bolt Carr Sh 3/8-16 x 1-1/2 Gr. 5
21	873 68 05-00	Nut Crown Lock 5/16-18	130	872 11 05-06	Bolt Rdhdsqnk 5/16-18 unc x 3/4
22	532 16 91-65	Bracket Idler RR	131	532 16 56-61	Chute Bagger CRD 92cm
23	532 16 91-66	Bracket Idler HL	152	532 17 60-74	Cable Clutch
24	532 16 91-70	Bracket Suspension LF	158	817 72 04-08	Screw 1/4-20 x 1/2
25	532 16 91-71	Bracket Suspension RF	161	532 18 04-24	Blade Cross LH
26	532 16 52-37	Brace Support Susp Frt CRD	162	532 18 08-78	Adapter Weldment Blade
27	532 16 91-72	Bracket Asm. Susp RR	163	532 18 04-25	Blade Cross RH
28	532 16 91-68	Bracket Asm. Susp LR	164	532 00 33-66	Bearing Col. Strg.
30	532 17 39-84	Screw Thd Rolling	185	532 18 82-34	Head Asm Cable Clutch
31	532 18 76-90	Washer Spacer	--	532 18 18-57	Mandrel Asm Service
32	532 17 57-07	Mandrel Pulleys	--	532 18 18-58	Mandrel Asm CRD Lh Threads SVC
33	532 17 83-42	Nut Fig Top Lock	--	532 18 17-70	Deck Mower Complete
34	532 17 95-09	Bracket Gauge Wheel Lf			(Order separately gauge wheel components key nos. 116-119)
35	532 17 62-92	Bracket Gauge Wheel Rf			
36	532 14 67-63	Pulley Idler V-Groove Dim 4.25			
38	532 16 98-51	Spacer Hub Arm Idler 107 CRD			
39	872 11 06-22	Bolt Rdhd 3/8-16 unc x 2-3/4 Gr. 5			

NOTE: All component dimensions given in U.S. inches
1 inch = 25.4 mm

REPAIR PARTS

TRACTOR-MODEL NO. BM155H107RB (96061003100), PRODUCT NUMBER 960 61 00-31
BAGGER

KEY NO.	PART NO.	DESCRIPTION
1	532 16 52-49	Tube Handle Bagger CRD
2	872 14 04 -16	Bolt Carriage 1/4-20 x 2.0 Gr.5
3	532 12 39-76	Nut Lock 1/4 Lge Flg Gr. 5 Zinc
4	532 16 99-16	Handle Bagger w/Lvrs Gr. 5 Zinc
5	874 98 10-24	Screw Pan Head #10-24 x 1.50 Blk
6	874 98 10-32	Screw Pan Hd
7	873 40 10-00	Nut Wiz Lock Hex Serr/Hd #10-24
8	532 19 24-70	Cover Bagger
9	872 14 04-18	Bolt Carriage 1/4-20 x 2.25d x Gr.5
10	532 18 12-82	Tube Support Bagger CRD
11	532 16 57-19	Bracket Support Upper Bag CRD
12	532 18 88-48	Bracket Pivot LH
15	532 12 46-70	Retainer Spring
17	872 14 05-06	Bolt Rdhd Sht Sqnk 5/16-18 unc x 3/4
19	873 90 05-00	Nut Lock Hex Flange 5/16-18
20	532 18 88-47	Bracket Pivot RH
21	532 18 08-80	Bag Asm CRD
22	532 16 57-81	Bracket Side Bagger CRD
23	532 16 57-82	Tube Upper Bagger CRD
24	532 16 57-83	Tube Pivot Bagger CRD
25	532 18 01-24	Tube Front Bagger CRD
26	532 16 57-85	Tube Lower Bagger CRD
28	532 16 57-87	Grip Handle Black
31	532 16 94-84	Retainer Clip
32	532 12 68-75	Rivet Rd Hd Drilled 3/8 Dia
33	532 16 93-90	Plug Mulcher
34	532 16 55-70	Handle Mulcher
35	532 16 55-72	Pin Mulcher
36	819 13 20-12	Washer 13/32 x 1-1/4 x 12 Ga.
37	532 17 54-01	Plug Support Bagger CRD
38	872 01 05-20	Bolt 5/16-18 x 2-1/2
39	532 18 09-85	Seal
41	532 16 96-83	Bracket Vert Adj Bagger CRD
43	532 17 40-83	Plug Tubing End
44	532 19 33-12	Pin Clevis 3/8 x 11/16
45	532 19 33-13	Pin Clevis 3/8 x 2.00

NOTE: All component dimensions given in U.S. inches
1 inch = 25.4 mm



BESTGREEN

