

REPAIR PARTS MANUAL
MODEL NO. WZLT125H36C
LAWN TRACTOR

WIZARD

HOW TO USE THIS MANUAL

This manual is designed to provide the customer with a means to identify the parts on his/her tractor when ordering repair parts. The illustrations may or may not represent the actual assemblies; therefore, it is not recommended to use this manual as a guide to assemble or disassemble the tractor. Some hardware and parts are drawn larger in order to more readily identify them.

Each tractor has its own model number.

The model number for your tractor can be found on the fender under the seat.

When ordering parts, always give the following information:

- Product - "Lawn Tractor"
- Model Number - "WZLT125H36C"
- Part Number
- Part Description

TABLE OF CONTENTS

SCHEMATIC	3
ELECTRICAL	4-5
CHASSIS	6-7
DRIVE	8-9
STEERING ASSEMBLY	10-11
ENGINE	12-13
MOWER DECK	14-15
MOWER LIFT LEVER	16
SEAT	17
DECALS	18
WARRANTY	20

TRACTOR - - MODEL NO. WZLT125H36C, PRODUCT NO. 954 56 83-73

SCHEMATIC

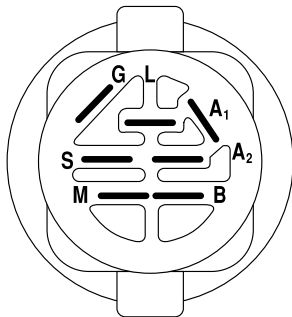
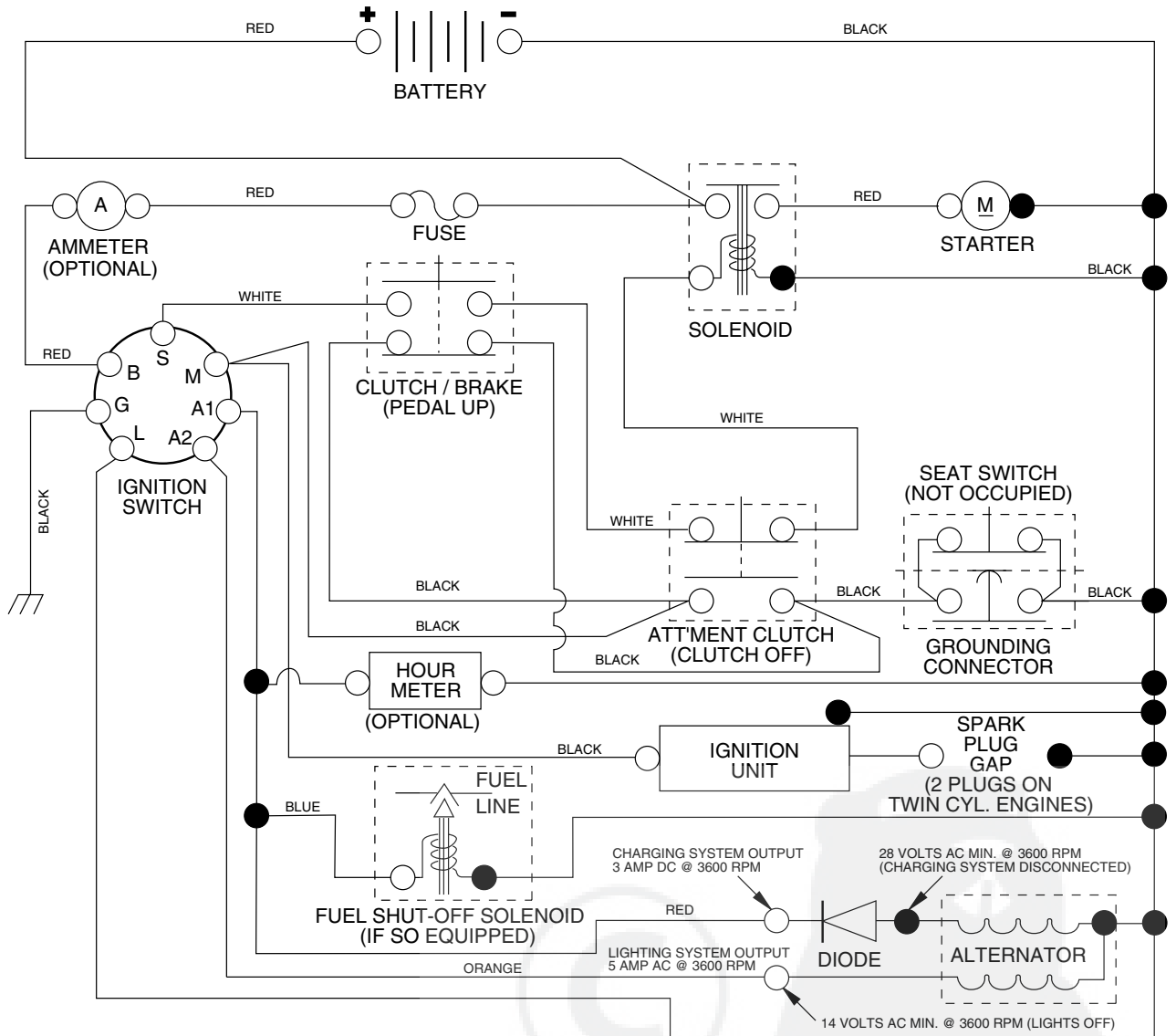

IGNITION SWITCH

POSITION	CIRCUIT	"MAKE"
OFF	M+G+A1	NONE
RUN/LIGHT	B+A1	A2+L
RUN	B+A1	NONE
START	B + S + A1	NONE

NOTE

YOUR TRACTOR IS EQUIPPED WITH A SPECIAL ALTERNATOR SYSTEM. THE LIGHTS ARE NOT CONNECTED TO THE BATTERY, BUT HAVE THEIR OWN ELECTRICAL SOURCE. BECAUSE OF THIS, THE BRIGHTNESS OF THE LIGHTS WILL CHANGE WITH ENGINE SPEED. AT IDLE THE LIGHTS WILL DIM. AS THE ENGINE IS SPEEDED UP, THE LIGHTS WILL BECOME THEIR BRIGHTEST.

WIRING INSULATED CLIPS

NOTE: IF WIRING INSULATED CLIPS WERE REMOVED FOR SERVICING OF UNIT, THEY SHOULD BE REPLACED TO PROPERLY SECURE YOUR WIRING.

NON-REMOVABLE CONNECTIONS

REMOVABLE CONNECTIONS

REPAIR PARTS

TRACTOR - - MODEL NO. WZLT125H36C, PRODUCT NO. 954 56 83-73
ELECTRICAL

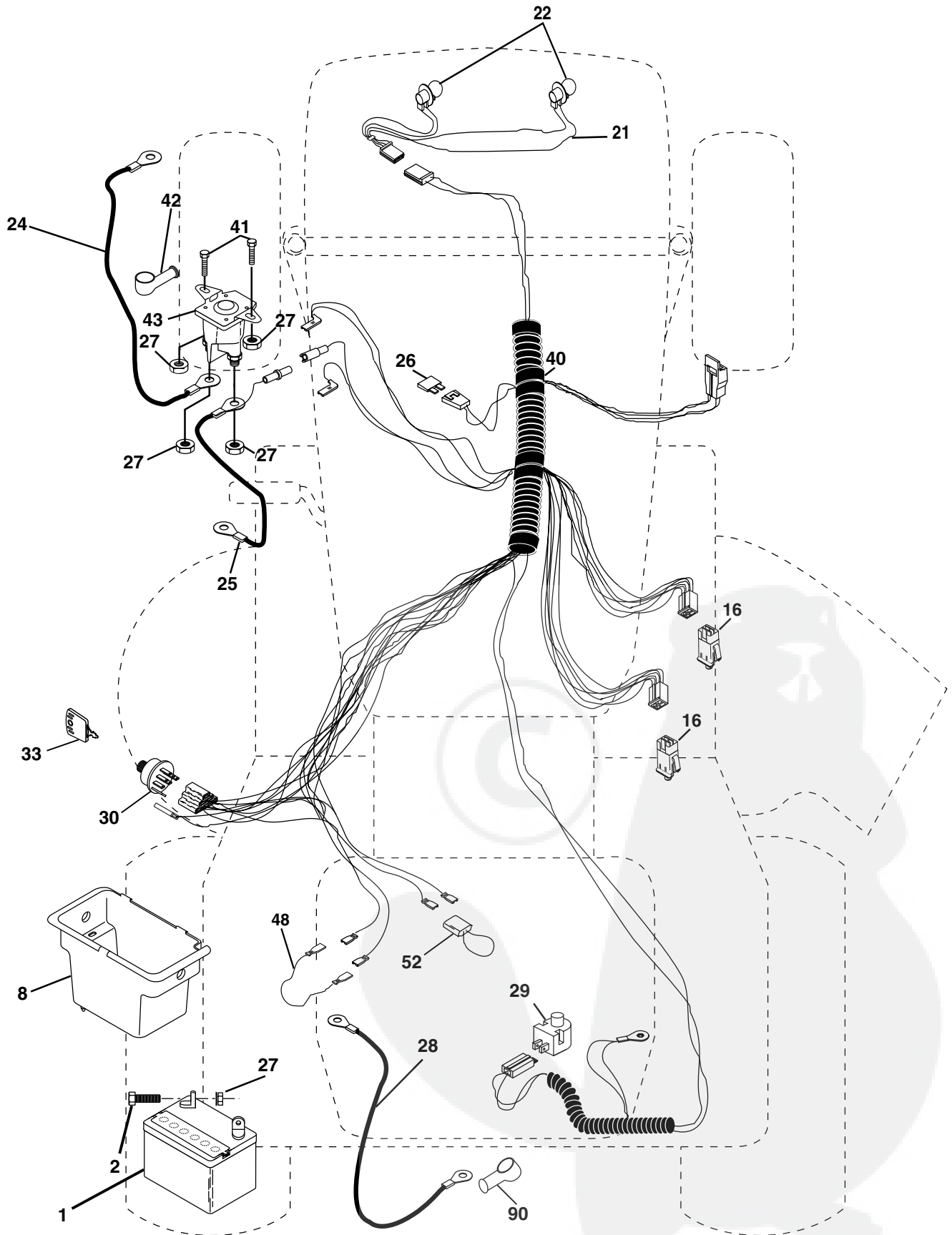

REPAIR PARTS

TRACTOR - - MODEL NO. WZLT125H36C, PRODUCT NO. 954 56 83-73
ELECTRICAL

KEY NO.	PART NO.	DESCRIPTION
1	163465	Battery 12 Volt 28 AMP
2	74760412	Bolt Hex Hd 1/4-20unc X 3/4
8	176689	Box Battery
16	176138	Switch Interlock Push-In
21	175685	Harness Asm Light W/4152j
22	4152J	Bulb Light #1156
24	4799J	Cable Battery 6 Ga 11" red
25	146147	Cable Battery 6 Ga 44" red
26	175158	Fuse
27	73510400	Nut Keps Hex 1/4-20
28	4207J	Cable Ground 6 Ga 12" black
29	121305X	Switch Plunger Nc Gray
30	175566	Switch Ign
33	140401	Key Ign
40	179720	Harness Ignition
41	71110408	Bolt Blk Fin Hex 1/4 - 20 x 1/2
42	131563	Cover Terminal Red
43	178861	Solenoid
48	140844	Adapter Ammeter
52	141940	Protection Wire Loop
90	180449	Cover Terminal

NOTE: All component dimensions give in U.S. inches
1 inch = 25.4 mm.



REPAIR PARTS

TRACTOR - - MODEL NO. WZLT125H36C, PRODUCT NO. 954 56 83-73
CHASSIS AND ENCLOSURES

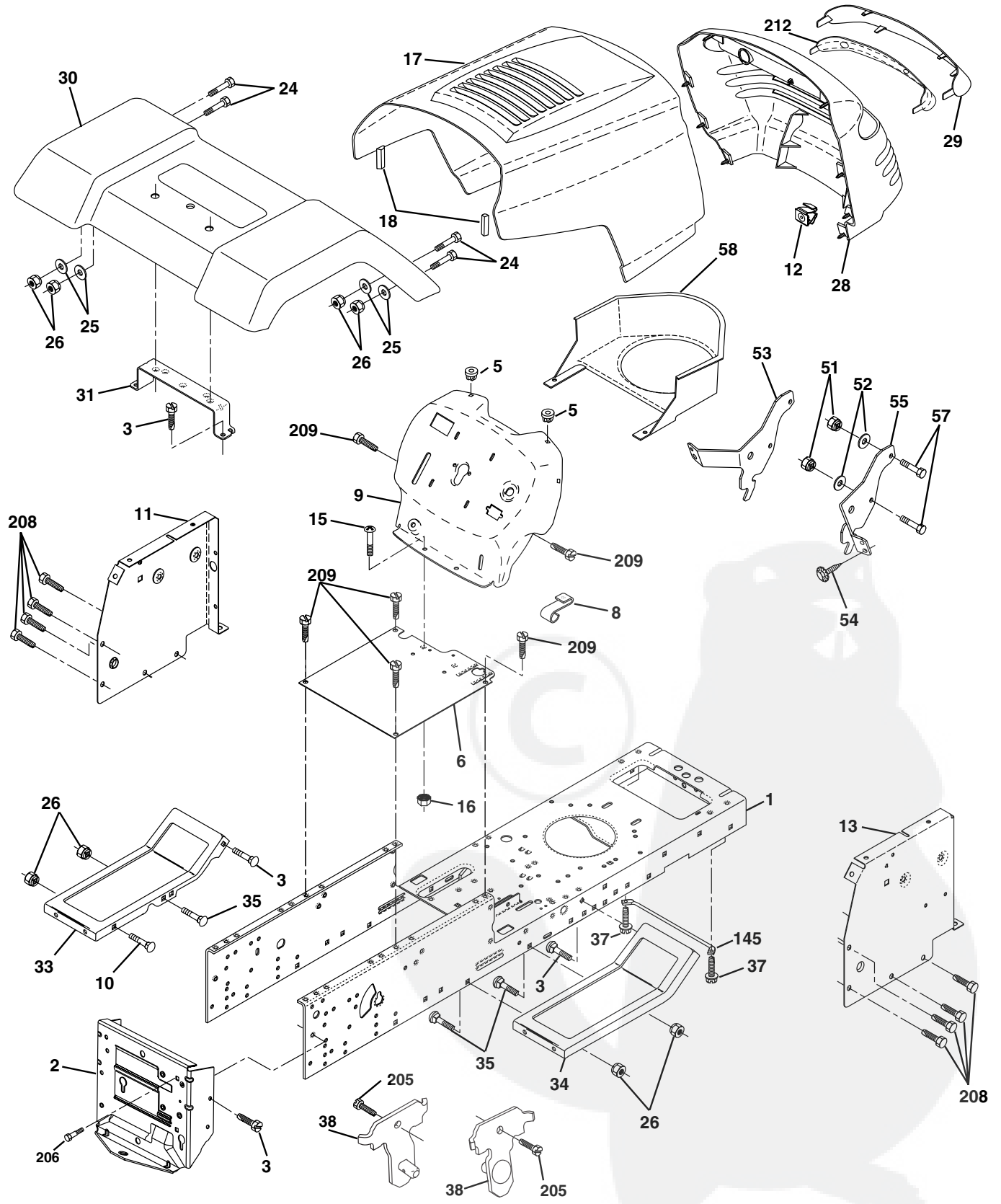

REPAIR PARTS

TRACTOR - - MODEL NO. WZLT125H36C, PRODUCT NO. 954 56 83-73 CHASSIS AND ENCLOSURES

KEY NO.	PART NO.	DESCRIPTION
1	174620	Chassis
2	176554	Drawbar 12 Ga.
3	17060612	Screw 3/8-16x3/4
5	155272	BumperHood/Dash
6	155923	Saddle LT Fender Shift
8	155138	Clip Retainer Slide-On
9	168347X011	Dash Private Label
10	72140608	Bolt Carriage 3/8-16 x 1
11	174996	Panel Pnt Dash Lh
12	145660	Clip Tinnerman Grille P/L
13	172105X010	Panel Dash Rh
15	74180512	Screw, Mach Trhd 5/16-18 UNC x 3/4
16	73510500	Nut Keps 5/16-18 UNC
17	159639X505	Hood Paint Steel Private Label
18	126938X	BumperHood
24	74780616	Bolt Fin Hex 3/8-16unc X 1 Gr. 5
25	19131312	Washer 13/32 X 13/16 X 12 Ga
26	73800600	Nut Lock Hex W/Ins 3/8-16 Unc
28	179101	Grille/Lens Asm.
29	140273X599	Lens Grille Private Label
30	169467X505	Fender Pnt
31	136619	Bracket Fender
33	179716X505	Footrest Pnt Lh
34	179717X505	Footrest Pnt Rh
35	72110606	Bolt Rdhd Sht Sqnk 3/8-16 X3/4
37	17490508	Screw Thdrol 5/16-18 x 1/2 Tyt
38	175710	Bracket, Asm. Pivot, Mower Rear
51	73800400	Nut Lock Hex W/Ins 1/4-20
52	19091416	Washer 9/32 x 7/8 x 16 Ga.
53	144697	Bracket, Grille, LH
54	161464	Screw Hex Wshd 8-18 x 7/8
55	144696	Bracket, Grille, RH
57	74780412	Bolt Hex 1/4-20 x 3/4
58	150127	Air Duct P/L
145	156524	Rod Pivot Chassis/Hood
205	17490608	Screw Thdrol 3/8-16 x 1/2
206	170165	Bolt, Shoulder 5/16-18
208	17670608	Screw 3/8-16 x 1/2 B.D.
209	17000612	Screw Hxwsh 3/8-16 x 3/4
212	156229	Insert Lens
--	5479J	Plug Button

NOTE: All component dimensions given in U.S. inches
1 inch = 25.4 mm

REPAIR PARTS

TRACTOR - - MODEL NO. WZLT125H36C, PRODUCT NO. 954 56 83-73

DRIVE

KEY NO.	PART NO.	DESCRIPTION	KEY NO.	PART NO.	DESCRIPTION
1	-----	Transaxle, Hydro Gear Model 322-0510 (Order parts from the transaxle manufacturer)	69	142432	Screw Hex Wsh Hi-Lo 1/4-1/2 Unc
8	165619	Rod, Shift	70	180218	Guide, Belt, Mower Drive RH
10	76020416	Pin, Cotter 1/8 x 1	71	169183	Strap, Torque, Lh
14	10040400	Washer Lock 1/4	73	169182	Strap, Torque, Rh
15	74490544	Bolt Hex Flghd 5/16-18 Gr. 5	74	137057	Spacer, Axle
16	73800500	Nut, Lock Hex w/Ins 5/16-18 UNC	75	121749X	Washer 25/32 x 1-1/4 x 16 Ga.
19	73800600	Nut, Lock Hex w/Wsh 3/8-16 UNC	76	12000001	Ring, E
21	106933X	Knob Rd. 1/2-13 Plstc. Thds. Blk.	77	123583X	Key, Square
22	169498	Rod, Brake	78	121748X	Washer 25/32 x 1-5/8 x 16 Ga.
24	73350600	Nut	81	165596	Shaft Asm Cross
25	106888X	Spring, Rod, Brake	82	123782X	Spring, Torsion
26	19131316	Washer 13/32 x 13/16 x 16 Ga.	83	19171216	Washer 17/32 x 3/4 x 16 Ga.
27	76020412	Pin, Cotter 1/8 x 3/4	84	169843	Link Transaxle
28	175765	Rod, Parking Brake	89	169373X428	Console, Shift
29	71673	Cap, Parking Brake	95	170201	Control Asm Bypass Hydro
30	174973	Bracket, Transmission	96	4497H	Spring, Retainer 1"
32	74760512	Bolt Hex 5/16-18 UNC x 3/4	120	73900600	Nut, Lock Flg. 3/8-16
34	175578	Shaft, Foot Pedal	103	73940800	Nut, Hex Jam Toplock 1/2-20 UNF
35	120183X	Bearing, Nylon	116	72140608	Bolt Rdhd Sq Neck 3/8-16 x 1
36	19211616	Washer	150	175456	Spacer Retainer
37	1572H	Pin, Roll	151	19133210	Washer 13/32 x 2 x 10
38	179114	Pulley, Idler, Flat	156	166002	Washer 5/16 x 1.0 x 1.25
39	74760648	Bolt	158	165589	Bracket Shift Mount
41	175556	Keeper, Belt, Idler	159	165494	Hub Tapered Flange Shift
47	127783	Pulley, Idler, V-Belt	161	72140406	Bolt Rdhd Sqnk 1/4-20 x 3/4 Gr. 5
48	154407	Bellcrank Clutch Grnd Drustl	162	73680400	Nut Crownlock 1/4-20 Unc
49	123205X	Retainer, Belt	163	74780416	Bolt Hex Fin 1/4-20 x 1
50	74760624	Bolt	164	19091010	Washer 5/8 x .281 x 10 Ga.
51	73680600	Nut	165	165623	Bracket Pivot Lever
52	73680500	Nut Crownlock 5/16-28	166	166880	Screw 5/16 x 1.0 x .125
53	105710X	Link, Clutch	168	165492	Bolt Shoulder 5/16-18 x .561
55	105709X	Spring, Return, Clutch	169	165581	Plate Fastener Cross Shaft
56	17060620	Screw 3/8-16 x 1-1/4	197	169613	Nyliner Snap-in 5/8" ID
57	140294	V-Belt, Drive	198	169593	Washer Nyl 7/8ID x .105"HYD
59	169691	Keeper, Belt, Center	199	169612	Bolt Shoulder 5/16-18 Unc
61	17120614	Screw 3/8-16 x .875	200	72140508	Bolt Rdhd Sqnk 5/16-18 Unc x 1
62	8883R	Cover, Pedal	202	72110614	Bolt Car SH 3/8-16 x 1-3/4 Gr 5
63	180219	Pulley, Engine	205	19171616	Washer 17/32 x 1 x 16 Ga
64	71170764	Bolt Hex 7/16 x 4 Gr. 5	212	145212	Nut Hexflange Lock
65	10040700	Washer	250	17060612	Screw, 3/8-16 x 3/4
66	154778	Keeper, Belt Engine Hydro			

NOTE: All component dimensions given in U.S. inches
1 inch = 25.4 mm

REPAIR PARTS

TRACTOR - - MODEL NO. WZLT125H36C, PRODUCT NO. 954 56 83-73
STEERING ASSEMBLY

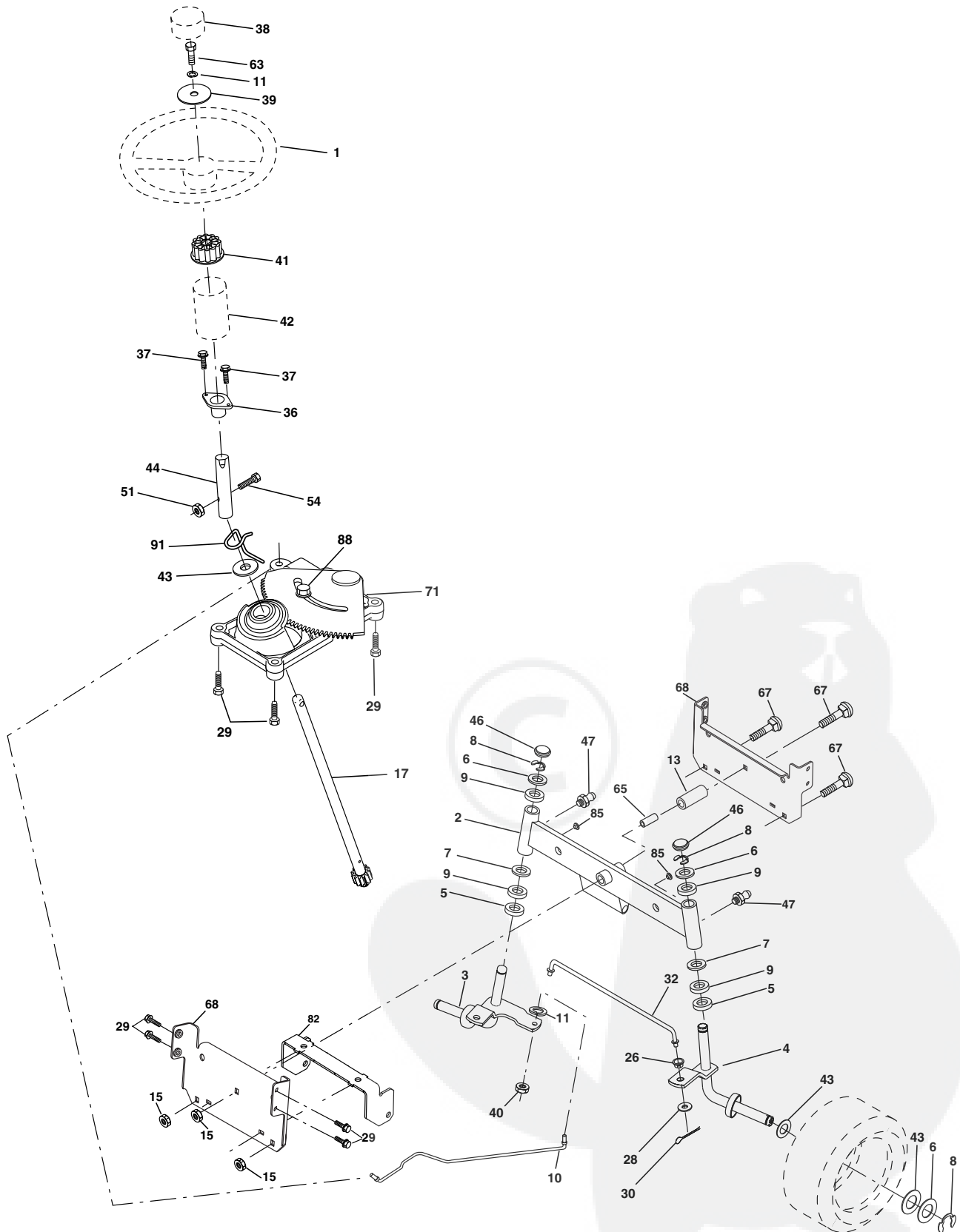

REPAIR PARTS

TRACTOR - - MODEL NO. WZLT125H36C, PRODUCT NO. 954 56 83-73 STEERING ASSEMBLY

KEY NO.	PART NO.	DESCRIPTION
1	140044X428	Wheel Steering Blk
2	175131	Axle Asm Fr LT/STL 2001
3	169840	Spindle Asm LH
4	169839	Spindle Asm RH
5	6266H	Bearing Race Thrust Harden
6	121748X	Washer 25/32 X 1-5/8 X 16 Ga
7	19272016	Washer 27/32 X 1-1/4 X 16 Ga
8	12000029	Ring Klip #t5304-75
9	3366R	Bearing Col Strg Blk
10	175121	Link Drag
11	10040600	Washer Lock Hvy Hlcl Spr 3/8
13	136518	Bearing Axle
15	145212	Nut Lock Flange
17	177876	Shaft Asm Strg Private Label
26	126847X	Bushing Link Drag Blk LR
28	19131416	Washer 13/32 X 7/8 X 16 Ga
29	17060612	Screw 3/8-16x3/4
30	76020412	Pin Cotter 1/8 X 3/4 Cad
32	130465	Rod Tie Wire Form 19 75 Mech
36	155099	Bushing Strg
37	152927	Screw TT #10-32 X 5 X 3/8 Flange
38	140045X428	Cap Strg Wh AYP P/L
39	19133812	Washer 13/32 X 2-3/8 X 12 Ga
40	7810H	Nut Lock Center 3/8-24unf
41	100711L	Adaptor Wheel Strg 758/753 ID
42	145054X428	Boot Steering
43	121749X	Washer 25/32 X 1 1/4 X 16 Ga
44	153720	Shaft Extention Steering
46	121232X	Cap Spindle Fr Top Blk
47	6855M	Fitting Grease
51	73800500	Nut Lock Hex w/Ins 5/16-18
54	74780520	Bolt Fin Hex 5/16-18 Unc x 1-1/4
63	74780616	Bolt Fin Hex 3/8-16 x 1 Gr. 5
65	160367	Spacer Axle
67	72140618	Bolt Rdhd 3/8-16 x 2-1/4
68	169827	Brace Axle
71	175146	Steering Asm LT/STL
82	169835	Bracket, Susp. Chassis, Front
85	133835	Fastener, Christmas Tree
88	175118	Bolt Shoulder 5/16-18 Unc
91	175553	Clip Steering Black

NOTE: All component dimensions given in U.S. inches.
1 inch = 25.4 mm.

REPAIR PARTS

TRACTOR - - MODEL NO. WZLT125H36C, PRODUCT NO. 954 56 83-73
ENGINE

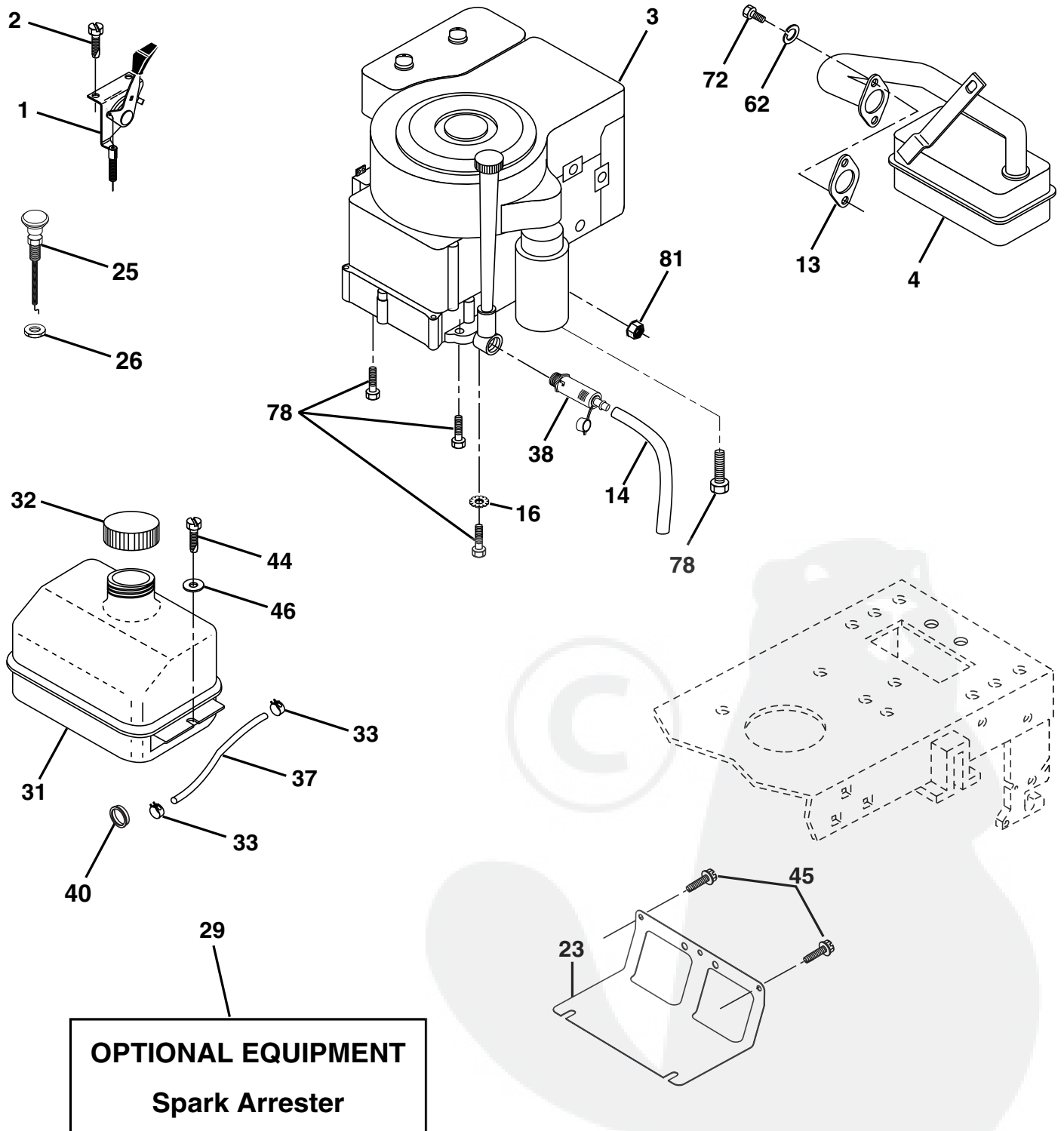

REPAIR PARTS

TRACTOR - - MODEL NO. WZLT125H36C, PRODUCT NO. 954 56 83-73
ENGINE

KEY NO.	PART NO.	DESCRIPTION
1	170551	Control Th/ch Flag
2	17720408	Screw Hex Thd Cut 1/4-20 x 1/2 T
3	-----	Engine, Briggs Model 289707 Order Parts From Engine Manufacturer
4	137348	Muffler LT B&S
13	165291	Gasket Eng
14	148456	Tube Drain Oil Easy
16	11050600	Washer Lock Ext Tooth 3/8
23	169837	Shield Brn/Dbr Guard
25	180945	Control Choke
26	73920600	Nut Keps 3/8-24 Unf
29	137180	Kit Spark Arrestor (Flat Scrm)
31	109202X	Tank Fuel Front
32	140527	Cap Asm Fuel W/sym Vented
33	123487X	Clamp Hose Black
37	137040	Line Fuel 20"
38	148315	Plug Drain Oil Easy
40	124028X	Busing Snap Nyl Blk Fuel Line
44	17670412	Screw Hexwsh Thdrol 1/4-20x3/4
45	17000612	Screw Hxwsh 3/8-16 x 3/4 BD
46	19091416	Washer 9/32 X 7/8 X 16 Ga
62	10040500	Washer Lock Hvy Hlcl Spr 5/16
72	71070512	Screw Hexhd Cap 5/16-18x 3/4
78	17060620	Screw Thdrol 3/8-16x1-1/4 TYTT
81	73510400	Nut Flange 1/4-20 Starter Nut

NOTE: All component dimensions given in U.S. inches.
1 inch = 25.4 mm.

REPAIR PARTS

TRACTOR - - MODEL NO. WZLT125H36C, PRODUCT NO. 954 56 83-73

MOWER DECK

KEY NO.	PART NO.	DESCRIPTION	KEY NO.	PART NO.	DESCRIPTION
1	174595	Mower Deck Assembly	56	165723	Spacer, Retainer
2	72140506	Bolt	67	106932X	Knob Round
3	138017	Bracket Assembly, Sway Bar, Front	68	180213	V-Belt
4	175654	Bracket Sway Bar	69	76020312	Pin cotter 3/32 x 3/4 Cad
5	4939M	Retainer Spring	89	19131612	Washer 13/32 x 1 x 12 Ga.
6	178024	Bar Sway Deck	107	133502	Spacer Arm Idler Upr Hdw
7	140608	Keeper Belt Lh	108	133503	Stiffener Arm Idler Upper
8	850857	Bolt, Hex 3/8-24 x 1.25 Gr. 8	113	17490508	Screw Thdrol 5/16-18 x 1/2
9	10030600	Washer, Lock	122	174505	Rod Brake Mandrel Lh
10	140296	Washer, Hardened	123	174504	Rod Brake Mandrel Rh
11	138496	Blade	146	165891	Bolt Carriage Idler
13	137645	Shaft Assembly, Mandrel, Vented	148	169022	Spring, Return, Idler
14	128774	Housing, Mandrel, Vented	149	165898	Retainer Spring Yellow Zinc
15	110485X	Bearing, Ball, Mandrel	150	19091216	Washer 9/32 x 3/4 x 16 Ga.
16	174493	Stripper, Mower Deck	151	169670	Bracket Clutch
19	132827	Bolt, Shoulder	152	176079	Cable Clutch
21	73680500	Nut Crownlock 5/16-18 UNC	153	169674	Washer Flat 3/8" Type B
23	136631	Bracket, Deflector	154	169675	Spring Retainer
24	105304X	Cap, Sleeve	155	169671	Spring Retention Lever
25	123713X	Spring, Torsion, Deflector	156	169672	Spacer
26	110452X	Nut, Push	157	169669	Rod Clutch
27	175029X428	Shield, Deflector	158	17720408	Screw Hex Thd Cut 1/4-20 x 1/2
28	19111016	Washer 11/32 x 5/8 x 16 Ga.	164	174976	Idler Asm Support & Susp. 36"
29	121980X	Rod, Hinge	168	172377	Bracket Deck Cable 36"
30	173984	Screw Thdrol Roll Hex	169	174977	Bracket Asm Suspension Rh
31	129963	Washer, Spacer	170	172359	Bracket Suspension Rf
32	153531	Pulley, Mandrel	171	165237	Brace Support Susp. Frt. CRD/36"
33	178342	Nut, Toplock, Flanged	172	172355	Bracket Suspension Lf
34	72110614	Bolt	--	130794	Mandrel Assembly (Includes Housing, Shaft and Shaft Hardware Only - Pulley Not Included)
36	131494	Pulley, Idler, Flat	--	181376	Replacement Mower, Complete
40	73680600	Nut Crownlock 3/8-16 UNC			
45	4497H	Retainer			
53	130840	Brake Asm Mower Vented			
54	133943	Washer, Hardened			
55	133840	Arm, Idler			

NOTE: All component dimensions given in U.S. inches
1 inch = 25.4 mm

REPAIR PARTS

TRACTOR - - MODEL NO. WZLT125H36C, PRODUCT NO. 954 56 83-73
LIFT

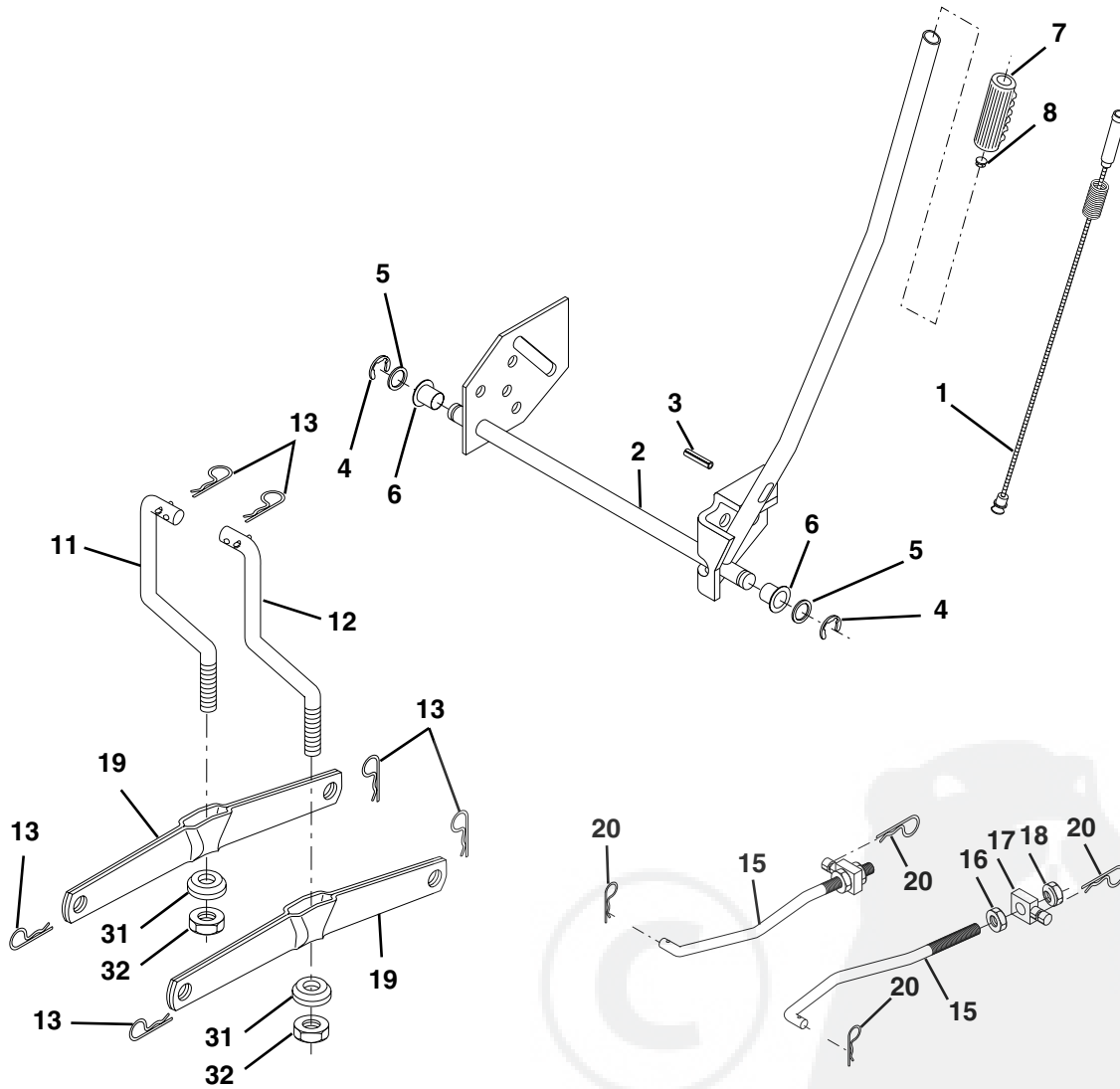

KEY NO.	PART NO.	DESCRIPTION
1	159460	Wire Asm Inner/Sprg w/plunger
2	159471	Shaft Asm Lift
3	105767X	Pin Groove
4	12000002	E Ring #5133-62
5	19211621	Washer 21/32 X 1 x 21 Ga
6	120183X	Bearing Nylon
7	109413X	Grip Handle Bicycle Matte Blk
8	124526X	Button Plunger
11	139865	Link Lift LH
12	139866	Link Lift RH

KEY NO.	PART NO.	DESCRIPTION
13	4939M	Retainer Spring
15	173288	Link Front
16	73350800	Nut Jam Hex 1/2-13 Unc
17	175689	Trunnion
18	73800800	Nut Lock W/wsh 1/2-13 Unc
19	139868	Arm Suspension Rear
20	163552	Retainer Spring
31	169865	Bearing Pvt. Lift
32	73540600	Nut Crownlock 3/8-24

NOTE: All component dimensions given in U.S. inches
1 inch = 25.4 mm

REPAIR PARTS

TRACTOR - - MODEL NO. WZLT125H36C, PRODUCT NO. 954 56 83-73
SEAT ASSEMBLY

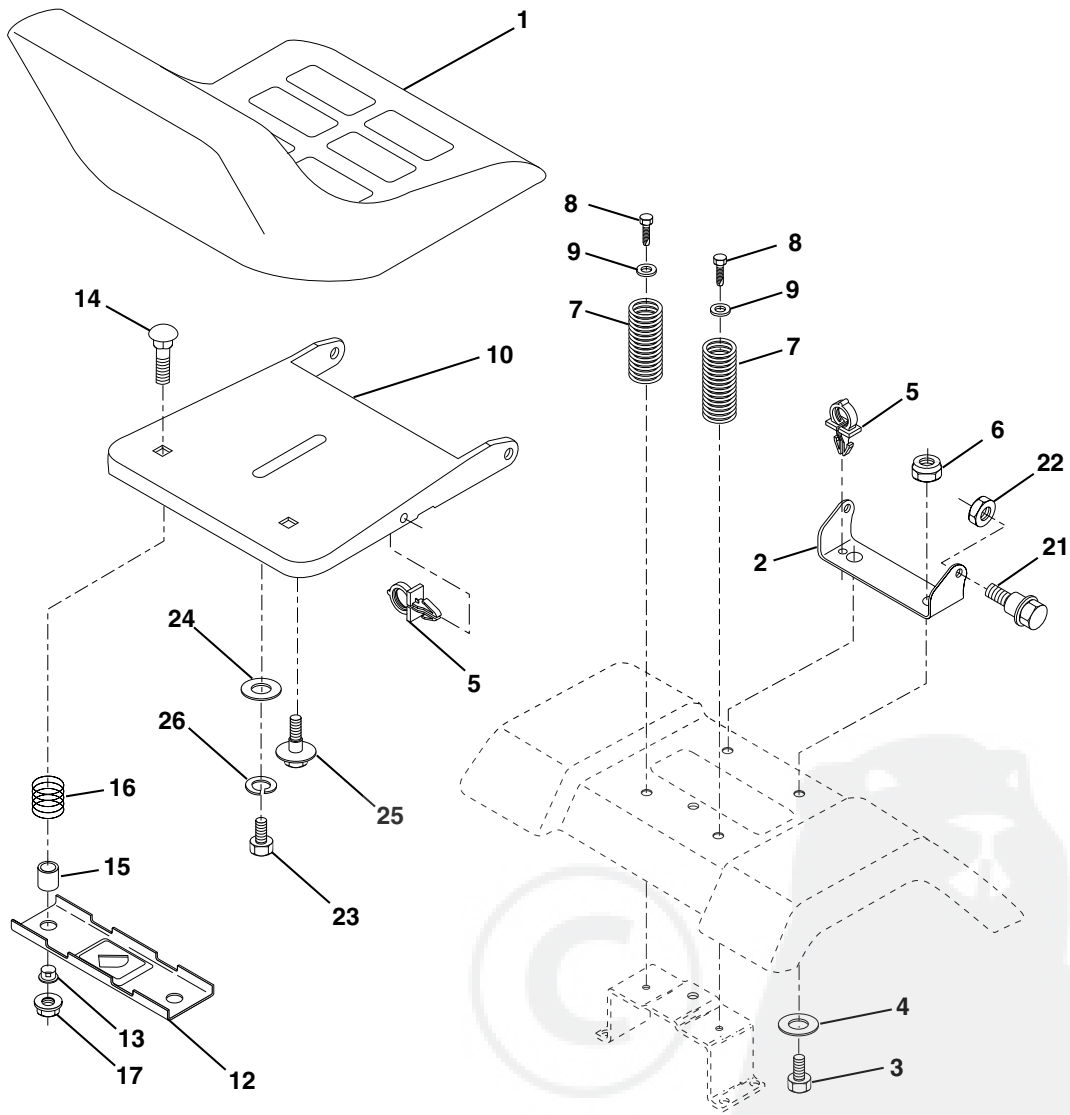

KEY NO.	PART NO.	DESCRIPTION
1	127426X	Seat
2	140551	Bracket Pivot Seat
3	71110616	Bolt Hex 3/8 - 16 x 1 Blk
4	19131610	Washer 13/32 x 1"
5	145006	Clip Push-In
6	73800600	Locknut, Hex W/Ins 3/8 - 16 Unc
7	124181X	Spring Seat Cprsn 2 250 Blk Zi
8	17000616	Screw Thdrol 3/8-16 x .5
9	19131614	Washer 13/32 x 1 x 14 Ga
10	174894	Pan Seat
12	121246X	Bracket Mounting Switch
13	121248X	Bushing Snap Blk Nyl 50 Id

KEY NO.	PART NO.	DESCRIPTION
14	72050412	Bolt Rdhd Sht Nk 1/4-20 x 1-1/2
15	134300	Spacer Split
16	121250X	Spring Cprsn
17	123976X	Nut Lock 1/4 Lge Flg Gr 5 Zinc
21	171852	Bolt Shoulder 5/16-18 UNC-2A BD
22	73800500	Locknut, Crown 5/16-18 UNC
23	71110814	Bolt Hex Black
24	19171912	Washer 17/32 x 1-3/16 x 12 Ga
25	127018X	Bolt Shoulder 5/16-18 x 62
26	10040800	Washer Lock Hvy Hlcl Spr 1/2

NOTE: All component dimensions given in U.S. inches
1 inch = 25.4 mm

REPAIR PARTS

TRACTOR - - MODEL NO. WZLT125H36C, PRODUCT NO. 954 56 83-73

DECALS

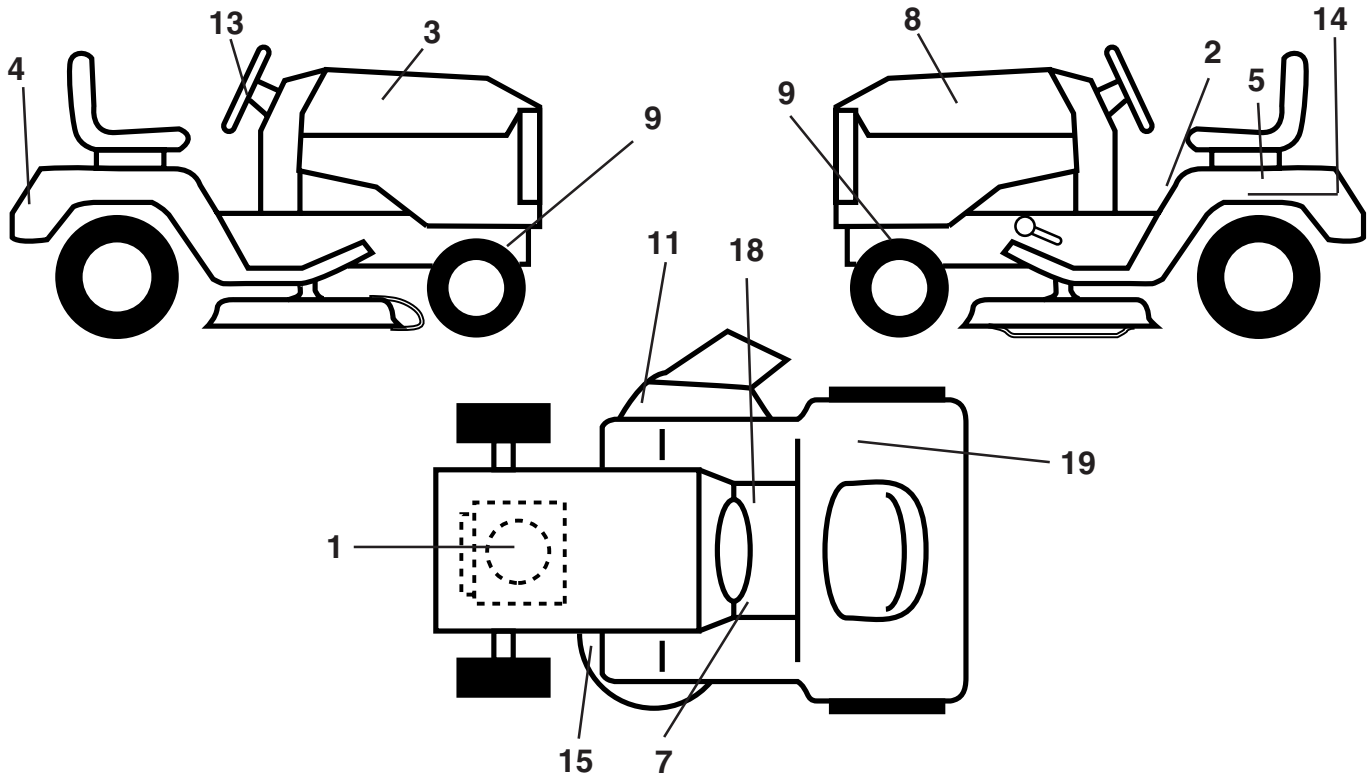

KEY NO.	PART NO.	DESCRIPTION
1	170839	Decal Engine
2	145498	Decal Read Owners Manual Syms
3	176020	Decal Hood RH
4	172175	Decal Hood/Fender
5	163465	Decal Battery
7	159737	Decal Brake/Clutch Symbol LT
8	176021	Decal Hood LH
9	159736	Decal Chassis Hot Muffler
11	182166	Decal Mower Cutting
13	167108	Decal Wheel Steering
14	145005	Decal Battery Dan/Poi/P/L

KEY NO.	PART NO.	DESCRIPTION
15	136832	Decal V-Belt Sch
18	140837	Decal Saddle Brake Parking
19	180432	Decal 100 DB/CE
--	179768X428	Pad Footrest LH
--	179769X428	Pad Footrest RH
--	138311	Decal Handle LFT Height Adj
--	169210	Decal Bypass
--	162598	Decal Drawbar Load Limit
--	181971	Manual Operator's (Euro)
--	181972	Manual Operator's (Scand)
--	181973	Manual Parts

WHEELS & TIRES

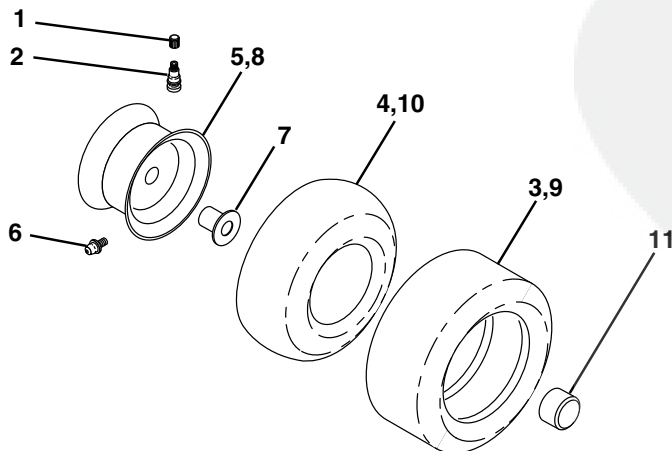

KEY NO.	PART NO.	DESCRIPTION
1	59192	Cap Valve Tire
2	65139	Stem Valve
3	106222X	Tire F Ts 15 X 6 0 - 6 Service
4	59904	Tube Front (Service Item Only)
5	106732X427	Rim Asm 6" (front White Service)
6	278H	Fitting Grease (Front Wheel Only)
7	9040H	Bearing Flange (Front Wheel Only)
8	106108X427	Rim Asm 8" (rear White Service)
9	124635X	Tire R Ts 18 x 8.5-8 C Service
10	7152J	Tube Rear (Service Item Only)
11	104757X428	Cap Axle Blk 1 50 X 1 00
--	144334	Sealant, Tire (10 oz. Tube)

NOTE: All component dimensions given in U.S. inches
1 inch = 25.4 mm.

SERVICE NOTES



LIMITED WARRANTY

The Manufacturer warrants to the original consumer purchaser that this product as manufactured is free from defects in materials and workmanship. For a period of one (1) year from date of purchase by the original consumer purchaser, we will repair or replace, at our option, without charge for parts or labor incurred in replacing parts, any part which we find to be defective due to materials or workmanship. This Warranty is subject to the following limitations and exclusions.

1. This warranty does not apply to the engine. Please contact your nearest dealer where they will send the machine to the engine manufacturer.
2. Transportation charges for the movement of any power equipment unit or attachment are the responsibility of the purchaser. Transportation charges for any parts submitted for replacement under this warranty must be paid by the purchaser unless such return is requested by your dealer.
3. Battery Warranty: On products equipped with a Battery, we will replace, without charge to you, any battery which we find to be defective in manufacture, during the first ninety (90) days of ownership. After ninety (90) days, we will exchange the Battery, charging you 1/12 of the price of a new Battery for each full month from the date of the original sale. Battery must be maintained in accordance with the instructions furnished.
4. The Warranty period for any products used for rental or commercial purposes is limited to 90 days from the date of original purchase.
5. This Warranty applies only to products which have been properly assembled, adjusted, operated, and maintained in accordance with the instructions furnished. This Warranty does not apply to any product which has been subjected to alteration, misuse, abuse, improper assembly or installation, delivery damage, or to normal wear of the product.
6. Exclusions: Excluded from this Warranty are belts, blades, blade adapters, normal wear, normal adjustments, standard hardware and normal maintenance.
7. In case of any problem within the boundaries of this warranty, contact the nearest department store, indicate the model number, serial number and the date of purchase of your machine. This warranty does not apply to accidental damages. All implicit warranties are limited to the same time frames. Or contact:

E.M. Services
54 Rue Lambrechts
92400 Courbevoie
France
Telephone: (1) 46678078
Fax: (1) 46678095

THIS WARRANTY DOES NOT APPLY TO INCIDENTAL OR CONSEQUENTIAL DAMAGES. ANY IMPLIED WARRANTIES ARE LIMITED TO THE SAME TIME PERIODS STATED HEREIN.



WIZARD