

**REPAIR PARTS MANUAL**  
**MODEL NO. M155B107HK (96011015400)**  
**Lawn Tractor**

---

**McCULLOCH®**

McCulloch  
[www.electrolux.com/mcculloch](http://www.electrolux.com/mcculloch)

532 40 25-78 11.10.05 TR  
PRINTED IN U.S.A.

# HOW TO USE THIS MANUAL

This manual is designed to provide the customer with a means to identify the parts on his/her tractor when ordering repair parts. The illustrations may or may not represent the actual assemblies; therefore it is not recommended to use this manual as a guide to assemble or disassemble the tractor. Some hardware and parts are drawn larger in order to more readily identify them.

Each tractor has its own model number.

The model number for your tractor can be found on the fender under the seat.

When ordering parts, always give the following information:

- Product - "Lawn Tractor"
- Model Number - "M155B107HK" (96011015400)
- Part Number
- Part Description

## TABLE OF CONTENTS

<b>SCHEMATIC .....</b>	<b>3</b>
<b>ELECTRICAL.....</b>	<b>4-5</b>
<b>CHASSIS AND ENCLOSURES.....</b>	<b>6-7</b>
<b>DRIVE.....</b>	<b>8-9</b>
<b>STEERING ASSEMBLY.....</b>	<b>10-11</b>
<b>SEAT ASSEMBLY .....</b>	<b>12</b>
<b>DECALS.....</b>	<b>13</b>
<b>ENGINE.....</b>	<b>14-15</b>
<b>MOWER DECK .....</b>	<b>16-17</b>
<b>LIFT .....</b>	<b>18-19</b>

# REPAIR PARTS

TRACTOR - MODEL NO. M155B107HK (96011015400), PRODUCT NO. 960 11 01-54  
ELECTRICAL

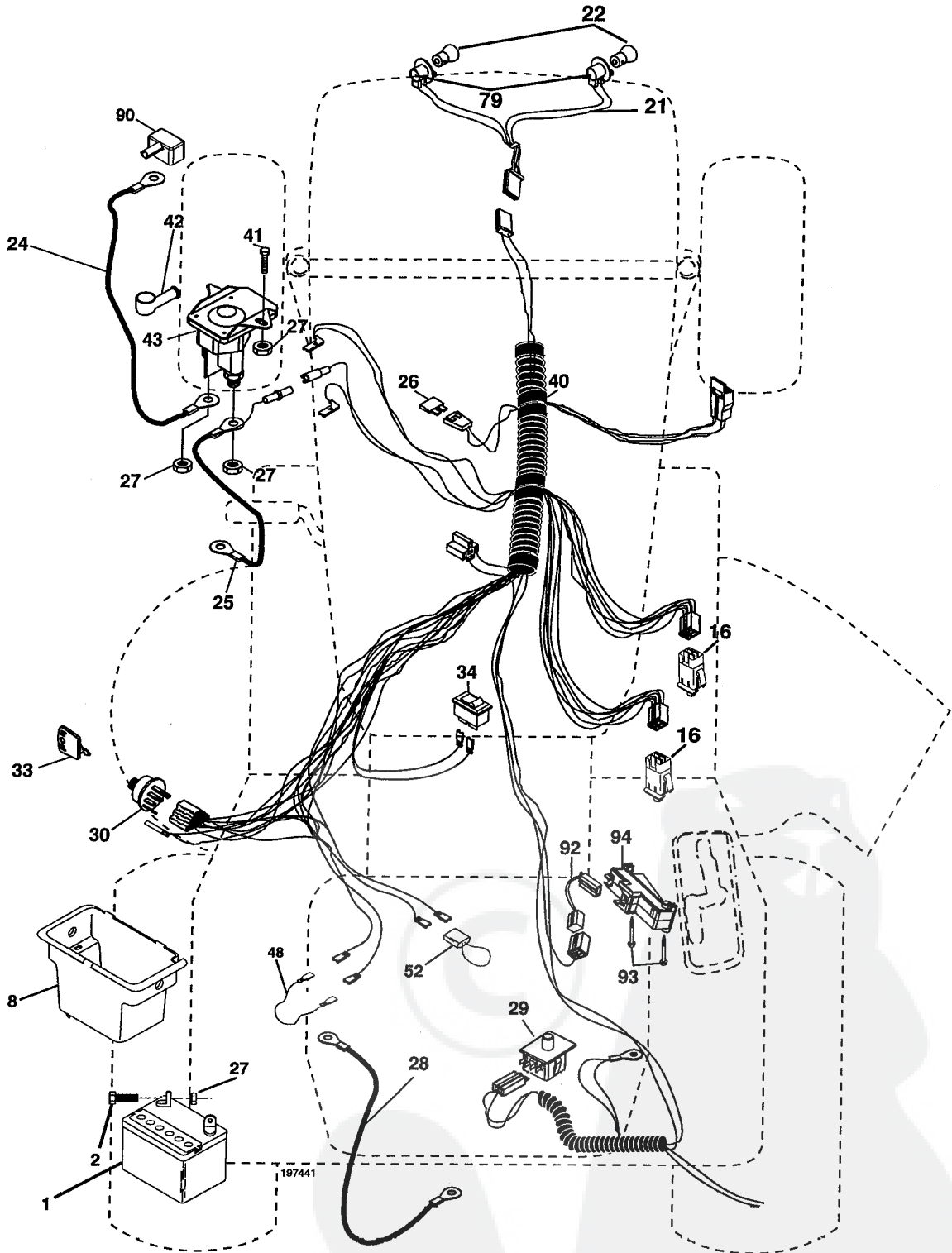

# REPAIR PARTS

TRACTOR - MODEL NO. M155B107HK (96011015400), PRODUCT NO. 960 11 01-54  
ELECTRICAL

KEY NO.	PART NO.	DESCRIPTION
1	532 16 34-65	Battery
2	874 76 04-12	Boit Hex Hd 1/4-20 unc x 3/4
8	532 17 66-89	Case Battery Mech Hinge
16	532 17 61-38	Switch Interlock
21	532 17 56-88	Harness Asm Light W/4152j
22	532 00 41-52	Bulb Light #1156
24	532 12 47-80	Cable Battery 6 Ga 11" red
25	532 14 61-47	Cable Battery 6 Ga 44" red w/16 wire
26	532 17 51-58	Fuse 20 AMP
27	873 51 04-00	Nut Keps Hex 1/4-20 unc
28	532 12 47-73	Cable Ground 6 Ga 12" black
29	532 19 27-49	Switch Seat
30	532 19 33-50	Switch Ign
33	532 14 04-01	Key Ign Molded Generic
34	532 11 07-12	Switch Lift/Reset B/B/Red
40	532 19 74-41	Harness Ign.
41	817 72 04-08	Screw 1/4-20 x 1/2
42	532 13 15-63	Cover Terminal Red
43	532 19 25-07	Solenoid
48	532 14 08-44	Adapter Ammeter Rectangular
52	532 14 19-40	Protection Wire Loop
79	532 17 52-42	Socket Asm. Bulb
90	532 18 04-49	Cover Terminal Battery
92	532 19 66-15	Harness Pigtail Console ROS
93	532 19 25-40	Screw Plastite 10-14 x 2.0
94	532 19 18-34	Module Reverse ROS

**NOTE:** All component dimensions given in U.S. inches.  
1 inch = 25.4 mm.

# REPAIR PARTS

TRACTOR - MODEL NO. M155B107HK (96011015400), PRODUCT NO. 960 11 01-54  
CHASSIS AND ENCLOSURES

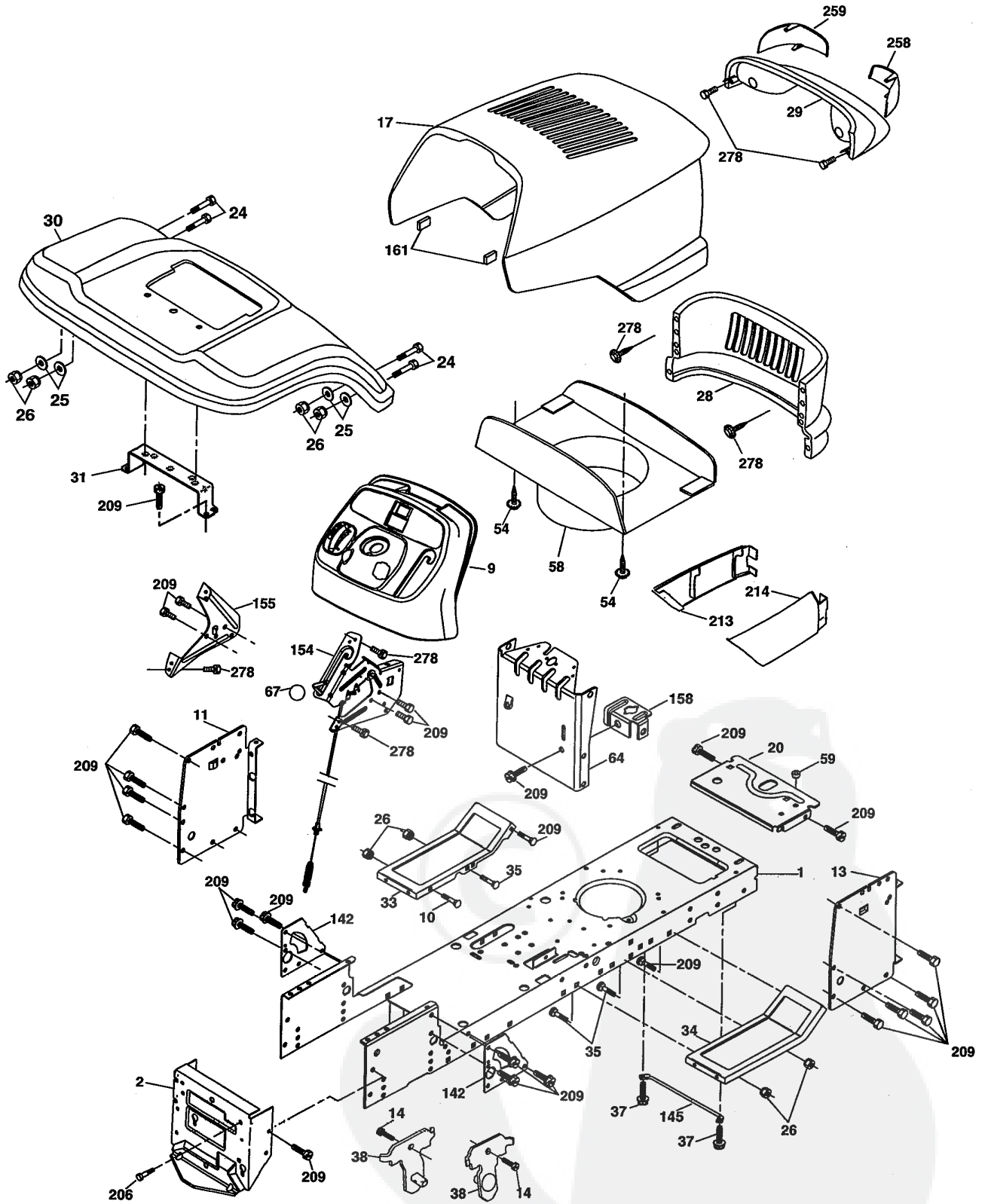

# REPAIR PARTS

TRACTOR - MODEL NO. M155B107HK (96011015400), PRODUCT NO. 960 11 01-54  
CHASSIS AND ENCLOSURES

KEY NO.	PART NO.	DESCRIPTION
1	532 17 46-19	Chassis Stamping
2	532 17 65-54	Drawbar, 12 Ga.
9	532 19 56-46	Dash Silscr
10	872 14 06-08	Bolt Carriage 3/8-16 x 1
11	532 16 72-03	Panel Dash Lh
13	532 19 49-76	Panel Dash Rh
14	817 49 06-08	Screw Thdrol 3/8-16 x 1/2
17	532 19 49-77	Hood
20	532 16 20-26	Plate Battery
24	874 78 06-16	Bolt Fin Hex 3/8-16unc x 1 Gr. 5
25	819 13 13-12	Washer 13/32 x 13/16 x 12 Ga.
26	873 80 06-00	Nut Lock Hex W/Ins 3/8-16 unc
28	532 18 71-14	Grille
29	532 17 97-63	Light Asm
30	532 19 41-98	Fender
31	532 13 66-19	Bracket Fender
33	532 18 25-07	Footrest Pnt Lh
34	532 18 25-08	Footrest Pnt Rh
35	872 11 06-06	Bolt Rdhd Sht Sqnk 3/8-16 x 3/4
37	817 49 05-08	Screw Thdrol 6/16-18 x 1/2 TYT
38	532 17 57-10	Bracket Asm Pivot Mower Rear
54	532 19 25-12	Screw Wshd Hex 10-32 x 5/8
58	532 19 03-08	Duct Air Engine
59	532 18 74-95	Bushing 1.375 OD
64	532 17 49-97	Dash Lower STLT
67	532 10 69-32	Knob
142	532 17 57-02	Plate Reinforcement STLT
145	532 15 65-24	Rod Pivot Chassis/Hood
154	532 19 24-13	Clutch Asm.
155	532 18 39-26	Bracket Dash LH
158	532 16 20-37	Bracket Parking Brake
161	532 16 46-55	Bumper Hood Extrusion
206	532 17 01-65	Bolt Shoulder 5/16-18 TT
209	817 00 06-12	Screw Hex Wsh Thdr. 3/8-16 x 3/4
213	532 18 71-12	Skirt Grille LH
214	532 18 71-11	Skirt Grille RH
258	532 16 18-42	Len RH
259	532 16 18-41	Len LH
278	532 19 16-11	Screw 10 x 3/4 Single Lead-Hex

**NOTE:** All component dimensions given in U.S. inches  
1 inch = 25.4 mm

# REPAIR PARTS

TRACTOR - MODEL NO. M155B107HK (96011015400), PRODUCT NO. 960 11 01-54  
DRIVE

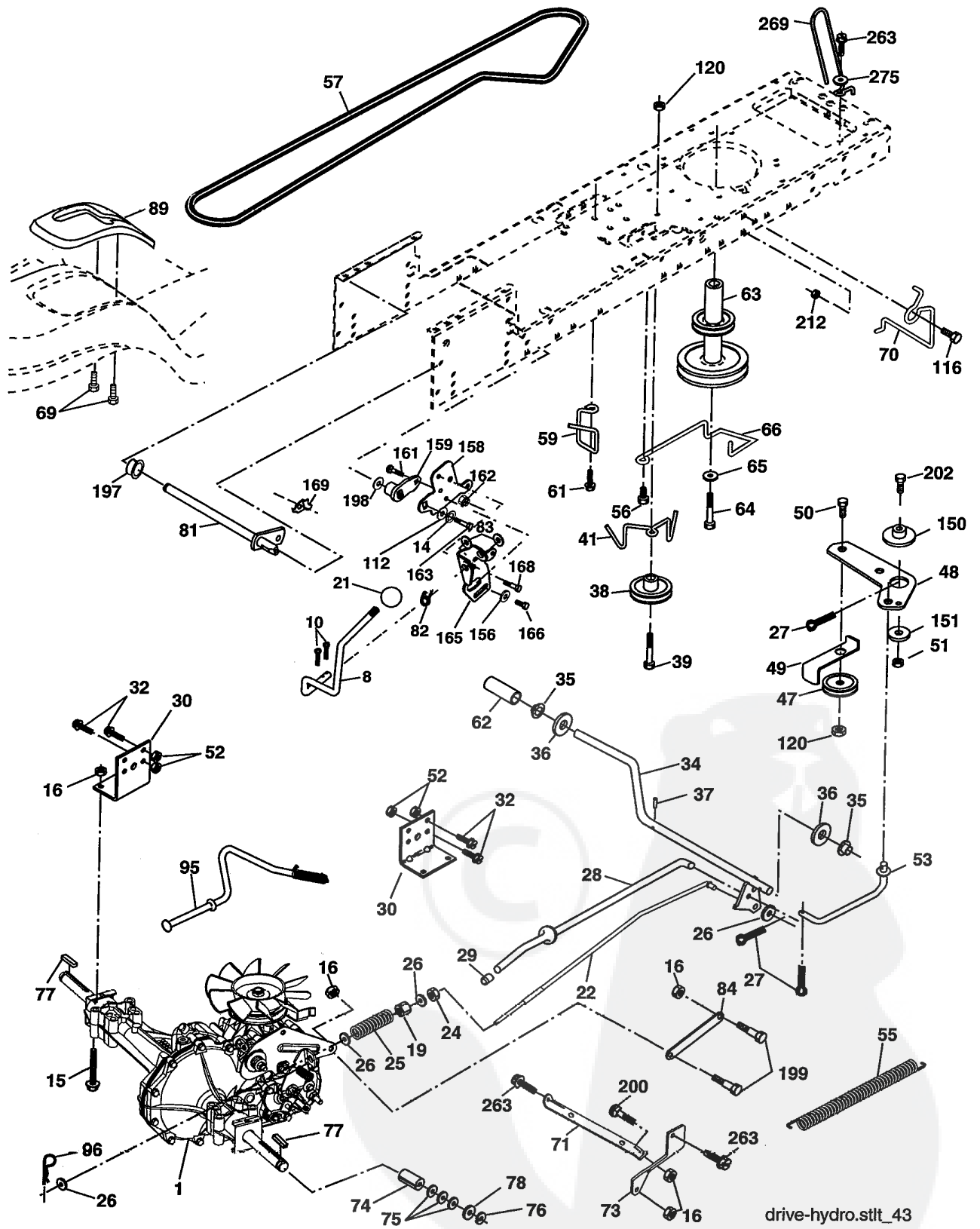

drive-hydro.stlt\_43

# REPAIR PARTS

**TRACTOR - MODEL NO. M155B107HK (96011015400), PRODUCT NO. 960 11 01-54  
DRIVE**

KEY NO.	PART NO.	DESCRIPTION	KEY NO.	PART NO.	DESCRIPTION
1	-----	Transaxle Hydro Gr Model 314-0510 (Order parts from transaxle mfg.)	71	532 16 91-83	Strap Torque Lh Hydro
8	532 19 27-06	Rod Shift Fender	73	532 16 91-82	Strap Torque Rh Hydro
10	876 02 04-16	Pin Cotter 1/8 x 1 CAD	74	532 13 70-57	Spacer, Axle
14	810 04 04-00	Washer Lock Hvy Helical 1/4	75	532 12 17-49	Washer 25/32 x 1-1/4 x 16 Ga.
15	874 49 05-44	Bolt Hex Flg Hd 5/16-18 X Gr.5	76	812 00 00-01	E-Ring
16	873 80 05-00	Nut Lock Hex W/Ins. 5/16-18 unc	77	532 12 35-83	Key, Square
19	873 80 06-00	Nut Lock Hex W/Wsh 3/8-16 unc	78	532 12 17-48	Washer 25/32 x 1-5/8 x 16 Ga.
21	532 10 69-33	Knob, Deluxe	81	532 16 55-96	Shaft Asm. Cross Hydro
22	532 16 94-98	Rod, Brake Hydro	82	532 16 57-11	Spring Torsion T/A
24	873 35 06-00	Nut	83	819 17 12-16	Washer 17/32 x 3/4 x 16 Ga.
25	532 10 68-88	Spring, Brake Rod	84	532 16 95-94	Link Transaxle
26	819 13 13-16	Washer	89	532 19 49-72	Console, Shift
27	876 02 04-12	Pin Cotter 1/8 x 3/4 CAD.	95	532 17 02-01	Control Asm Bypass Hydro
28	532 17 57-65	Rod, Parking Brake	96	532 12 47-88	Retainer Spring 1" Zinc/Cad
29	532 07 16-73	Cap, Parking Brake	112	819 09 12-10	Washer 9/32 x 3/4 x 10 Ga.
30	532 16 95-92	Bracket, Transaxle	116	872 14 06-08	Boulon 3/8-16 x 1
32	874 76 05-12	Bolt Hex Hd 5/16-18 unc x 3/4	120	873 90 06-00	Nut Lock Flg 3/8-16
34	532 17 55-78	Shaft, Foot Pedal	150	532 17 54-56	Spacer Retainer
35	532 12 01-83	Bearing, Nylon	151	819 13 32-10	Washer 13/32 x 2 x 10 Ga.
36	819 21 16-16	Washer	156	532 16 60-02	Washer Srrtd 5/16 ID x 1.0 x .125 Tk
37	532 12 49-63	Pin, Roll	158	532 16 55-89	Bracket Shift Mount
38	532 17 91-14	Pulley, Composite	159	532 18 39-00	Hub Shift
39	872 11 06-22	Bolt	161	872 14 04-06	Bolt Rdhd Sqnk 1/4-20 x 3/4 Gr. 5
41	532 17 55-56	Keeper, Belt Idler	162	873 68 04-00	Nut Crownlock 1/4-20 unc
47	532 12 77-83	Pulley, Idler, V-Groove	163	874 78 04-16	Bolt Hex Fin 1/4-20 unc x 1 Gr. 5
48	532 15 44-07	Bellcrank Clutch Grnd Drv Stl	165	532 16 56-23	Bracket Pivot Lever
49	532 12 32-05	Retainer, Belt	166	817 49 05-10	Screw 5/16-18 x 5/8 TT Yellow
50	872 11 06-12	Bolt Carr. Sh 3/8-16 x 1-1/2 Gr. 5	168	532 16 54-92	Bolt Shoulder 5/16-18 x .561 TT
51	873 68 06-00	Nut	169	532 16 55-80	Plate Fastening Cross Shf. STLT/CRD
52	873 68 05-00	Nut Crownlock 5/16-18	197	532 16 96-13	Nyliner Snap-In 5/8" ID
53	532 19 96-52	Link, Clutch	198	532 16 95-93	Washer Nyl. 7/8 ID x .105"
55	532 10 57-09	Spring, Return, Clutch	199	532 16 96-12	Bolt Shoulder 5/16-18 Unc
56	817 06 06-20	Screw 3/8-16 x 1-1/4	200	872 14 05-08	Bolt RdHd Sq Neck 5/16-18 unc x 1
57	532 14 02-94	V-Belt, Ground Drive	202	872 11 06-14	Bolt RdHd 3/8-16 x 1-3/4 Gr. 5
59	532 16 96-91	Keeper, Center Span	212	532 14 52-12	Nut Hex Flg Lock
61	817 12 06-14	Screw 3/8-16 x .875	263	817 00 06-12	Screw Hex Wsh Thdr. 3/8-16 x 3/4
62	532 12 48-72	Cover, Pedal	269	532 18 24-02	Guard Muffler OHV B&S RH
63	532 18 02-19	Pulley, Eng	275	819 13 16-14	Washer 13/32 x 1 x 14 Ga.
64	532 17 39-37	Bolt Hex 7/16-20 x 4 Ga. 5			
65	810 04 07-00	Washer			
66	532 15 47-78	Keeper Belt Engine			
69	532 14 24-32	Screw Hex Wsh Hi-Lo 1/4-1/2 unc			
70	532 18 02-18	Guide Belt Mower Drive RH			

**NOTE:** All component dimensions give in U.S. inches.  
1 inch = 25.4 mm.



# REPAIR PARTS

TRACTOR - MODEL NO. M155B107HK (96011015400), PRODUCT NO. 960 11 01-54  
STEERING ASSEMBLY

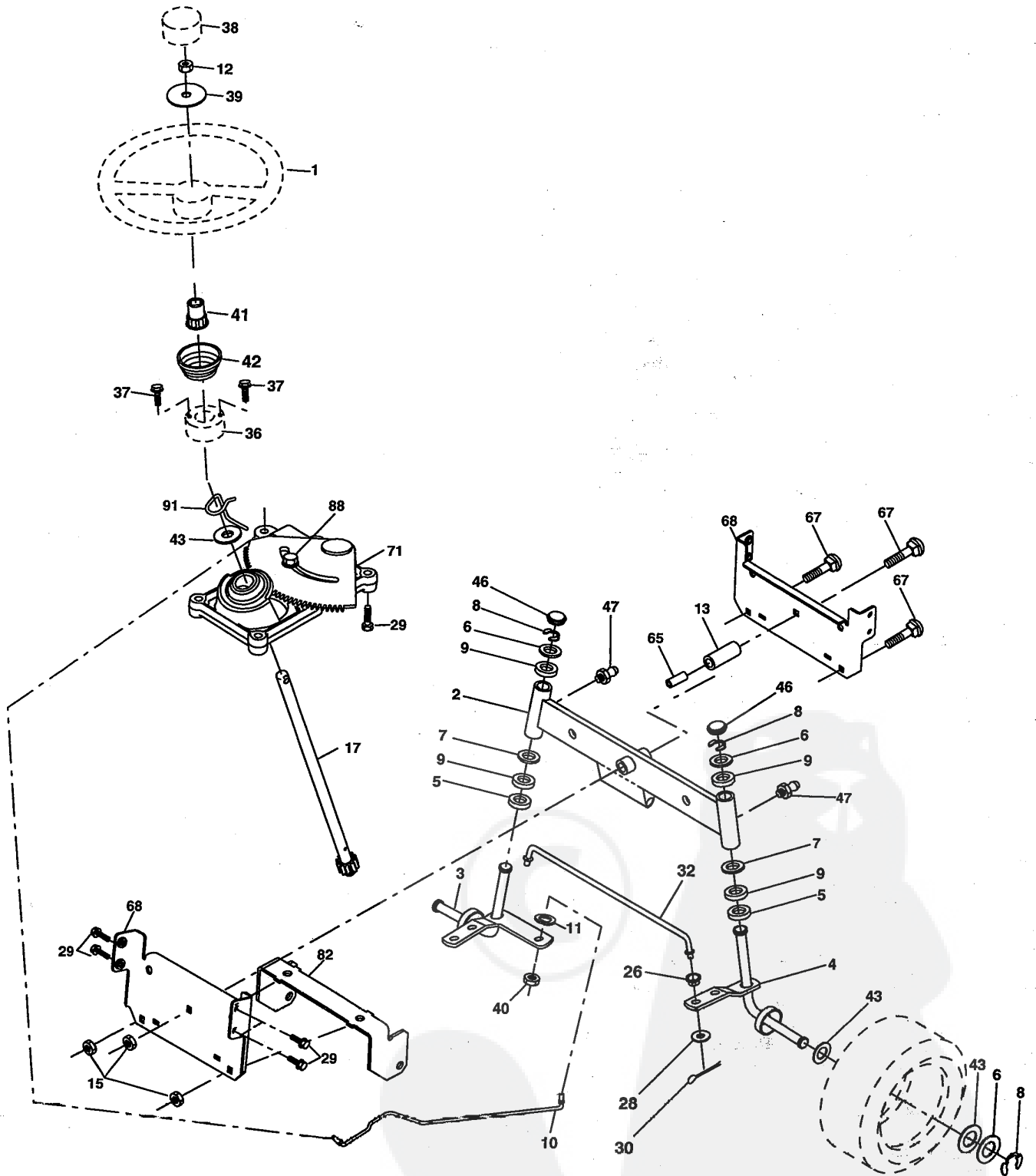

steering\_stealth\_prem\_14

# REPAIR PARTS

TRACTOR - MODEL NO. M155B107HK (96011015400), PRODUCT NO. 960 11 01-54  
STEERING ASSEMBLY

KEY NO.	PART NO.	DESCRIPTION
1	532 19 45-95	Steering Wheel
2	532 17 51-31	Axle Assembly STMP Dropped STL
3	532 16 98-40	Spindle Assembly, L.H.
4	532 16 98-39	Spindle Assembly, R.H.
5	532 12 49-31	Bearing, Race, Thrust, Hardened
6	532 12 17-48	Washer 25/32 x 1-5/8 x 16 Gauge
7	819 27 20-16	Washer 27/32 x 1-1/4 x 16 Gauge
8	812 00 00-29	Ring, Klip
9	532 12 49-37	Bearing, Steering Column
10	532 17 51-21	Draglink Extended Stamped
11	810 04 06-00	Washer, Lock
12	873 94 08-00	Nut hex Jam Toplock 1/2-20 unf
13	532 13 65-18	Spacer Brg Axle Front
15	532 14 52-12	Hex Flange Lock
17	532 17 78-83	Shaft Assembly, Steering
26	532 12 68-47	Bushing, Link, Drag
28	819 13 14-16	Washer 13/32 x 7/8 x 16 Ga.
29	817 00 06-12	Screw, 3/8-16 x 3/4
30	876 02 04-12	Pin
32	532 19 27-57	Rod, Tie
36	532 15 51-05	Bushing, Steering
37	532 15 29-27	Screw
38	532 19 46-03	Insert, Steering Wheel
39	819 18 38-12	Washer 9/16 ID x 2-3/8 OD 12 Ga. Zin
40	873 54 06-00	Nut Crownlock 3/8-24
41	532 18 67-37	Adaptor, Steering Wheel
42	532 17 71-49	Boot, Steering Shaft
43	532 12 17-49	Washer 25/32 x 1-1/4 x 16 Ga.
46	532 12 12-32	Cap, Spindle
47	532 18 32-26	Fitting, Grease
65	532 16 03-67	Spacer Brace Axle
67	872 11 06-18	Bolt Rdhd Sq 3/8-16 x 2-1/4
68	532 16 98-27	Axle, Brace
71	532 17 51-46	Steering Asm
82	532 19 99-78	Bracket Susp Chassis Front
88	532 17 51-18	Screw 3/8-16 x 1
91	532 17 55-53	Clip Steering
95	532 18 89-67	Washer Hardened .793 x 1.637 x .060

**NOTE:** All component dimensions given in U.S. inches  
1 inch = 25.4 mm

# REPAIR PARTS

TRACTOR - MODEL NO. M155B107HK (96011015400), PRODUCT NO. 960 11 01-54  
SEAT ASSEMBLY

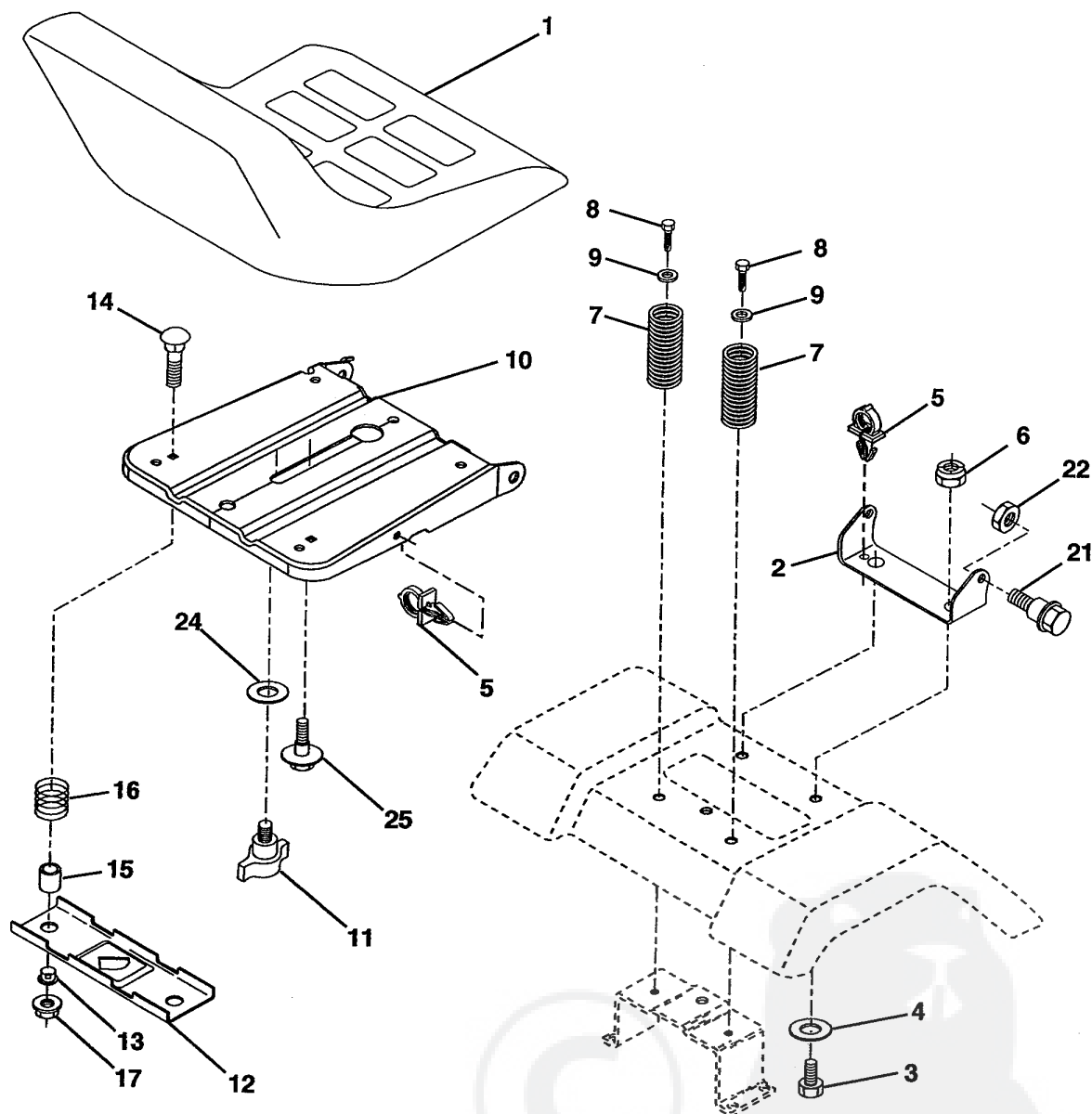

seat\_lt.knob\_13

KEY NO.	PART NO.	DESCRIPTION	KEY NO.	PART NO.	DESCRIPTION
1	532 18 87-13	Seat	13	532 12 12-48	Bushing Snap Blk Nyl 50 Id
2	532 14 05-51	Bracket Pivot Seat	14	872 05 04-12	Bolt Rdhd Sqnk 1/4-20 x 1 -1/2
3	871 11 06-16	Bolt Fin Hex 3/8-16 unc x 1	15	532 13 43-00	Spacer Split
4	819 13 16-10	Washer 13/32 x 1 x 10 Ga.	16	532 12 12-50	Spring Cprsn
5	532 14 50-06	Clip Push-In	17	532 12 39-76	Nut Lock 1/4 Lge Flg Gr. 5 Zinc
6	873 80 06-00	Nut Hex w/Ins. 3/8-16 unc	21	532 17 18-52	Bolt Shoulder 5/16-18 unc-2A
7	532 12 41-81	Spring Seat Cprsn 2 250 Blk Zi	22	873 80 05-00	Nut Hex Lock W/Ins 5/16-18
8	817 00 06-16	Screw 3/8-16 x 1	24	819 17 19-12	Washer 17/32 x 1-3/16 x 12 Ga.
9	819 13 16-14	Washer 13/32 x 1 x 14 Ga.	25	532 12 70-18	Bolt Shoulder 5/16-18 x .62
10	532 19 55-30	Pan Seat			
11	532 16 63-69	Knob Seat			
12	532 17 46-48	Bracket Mounting Switch			

**NOTE:** All component dimensions given in U.S. inches.  
1 inch = 25.4 mm

# REPAIR PARTS

TRACTOR - MODEL NO. M155B107HK (96011015400), PRODUCT NO. 960 11 01-54  
DECALS

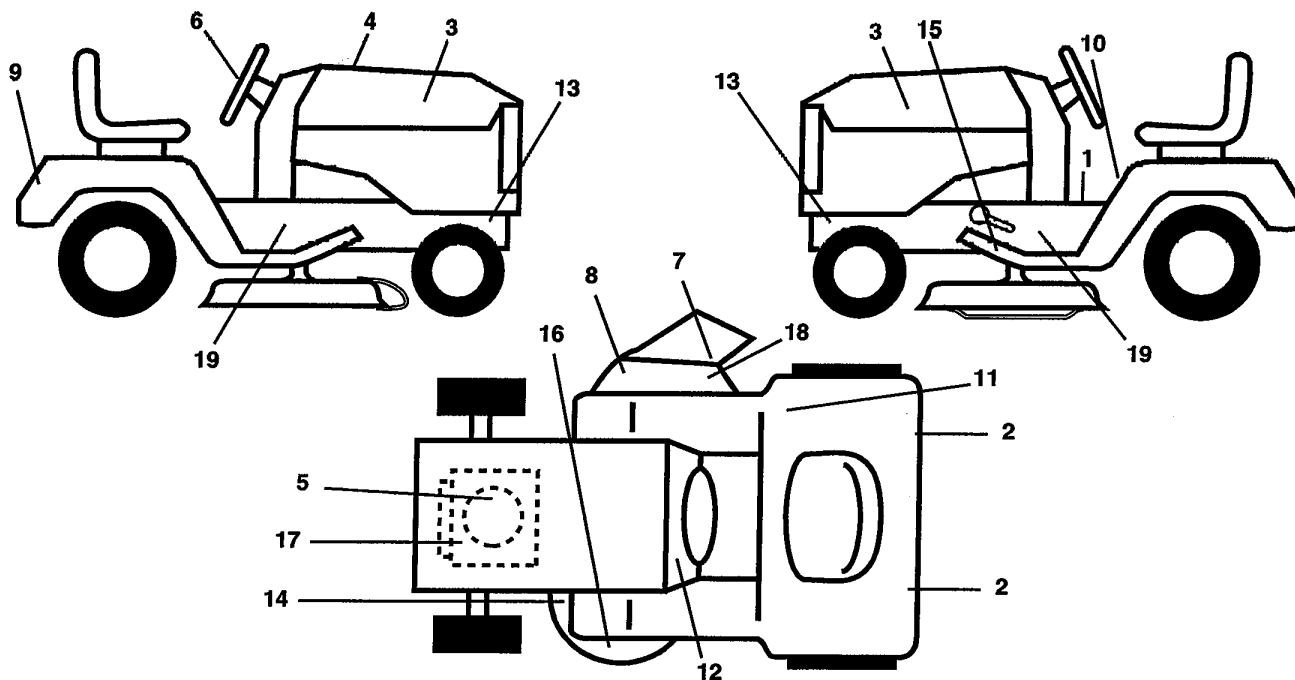

KEY NO.	PART NO.	DESCRIPTION	KEY NO.	PART NO.	DESCRIPTION
1	532 14 08-37	Decal Brake Parking Saddle	14	532 16 03-96	Decal V-Belt Schematic
2	532 10 62-02	Reflector Tail Light Red/Amber	15	532 15 97-37	Decal Brake/Clutch Sym.
3	532 40 20-32	Decal Hood	16	532 13 49-99	Decal Deck Enviro
4	532 14 50-05	Decal Bat. Dan/Poi	17	532 19 68-41	Decal Warning Eng. Sym.
5	532 19 80-65	Decal Engine	18	532 19 63-57	Decal Deflect. Wrn. Cutfngr Sym
6	532 40 18-60	Decal Wheel Steering	19	532 40 11-46	Decal Warning Service/Fire
7	532 17 91-28	Decal Deck B 42	--	532 16 69-60	Decal Bypass
8	532 18 21-66	Decal Cutfinger	--	532 13 83-11	Decal, Lift Handle
9	532 40 18-61	Decal Fender	--	532 18 10-90	Pad Footrest RH
10	532 40 03-89	Decal Warning Sym. CE	--	532 18 10-91	Pad Footrest LH
11	532 18 04-32	Decal Fender 100 DB/CE	--	532 16 25-98	Decal Drawbar
12	532 19 46-06	Decal Dash	--	532 40 08-95	Manual Operator's Euro.
13	532 15 97-36	Decal Chassis Muffler	--	532 40 25-78	Manual Parts

## WHEELS & TIRES

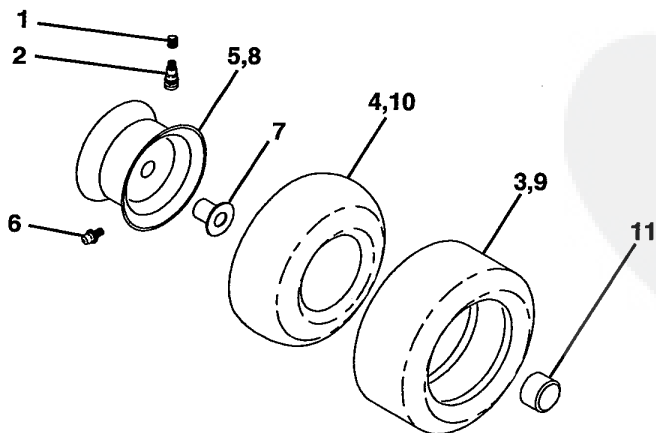

KEY NO.	PART NO.	DESCRIPTION
1	532 05 91-92	Cap Valve Tire
2	532 06 51-39	Stem Valve
3	532 10 62-22	Tire F Ts 15 x 6 0 - 6 Service
4	532 05 99-04	Tube Front (Service Item Only)
5	532 12 51-21	Rim Asm 6"front Service
6	532 12 49-57	Fitting Grease (Front Wheel Only)
7	532 12 49-59	Bearing Flange (Front Wheel Only)
8	532 12 51-22	Rim Asm 8"rear Service
9	532 13 84-68	Tire R Ts 20 x 8-8 C Service
10	532 12 49-26	Tube Rear (Service Item Only)
11	532 17 50-39	Cap Axle Blk 1 50 x 1 00
--	532 14 43-34	Sealant, Tire ( 10 oz. Tube)

NOTE: All component dimensions given in U.S. inches  
1 inch = 25.4 mm

# REPAIR PARTS

TRACTOR - MODEL NO. M155B107HK (96011015400), PRODUCT NO. 960 11 01-54  
ENGINE

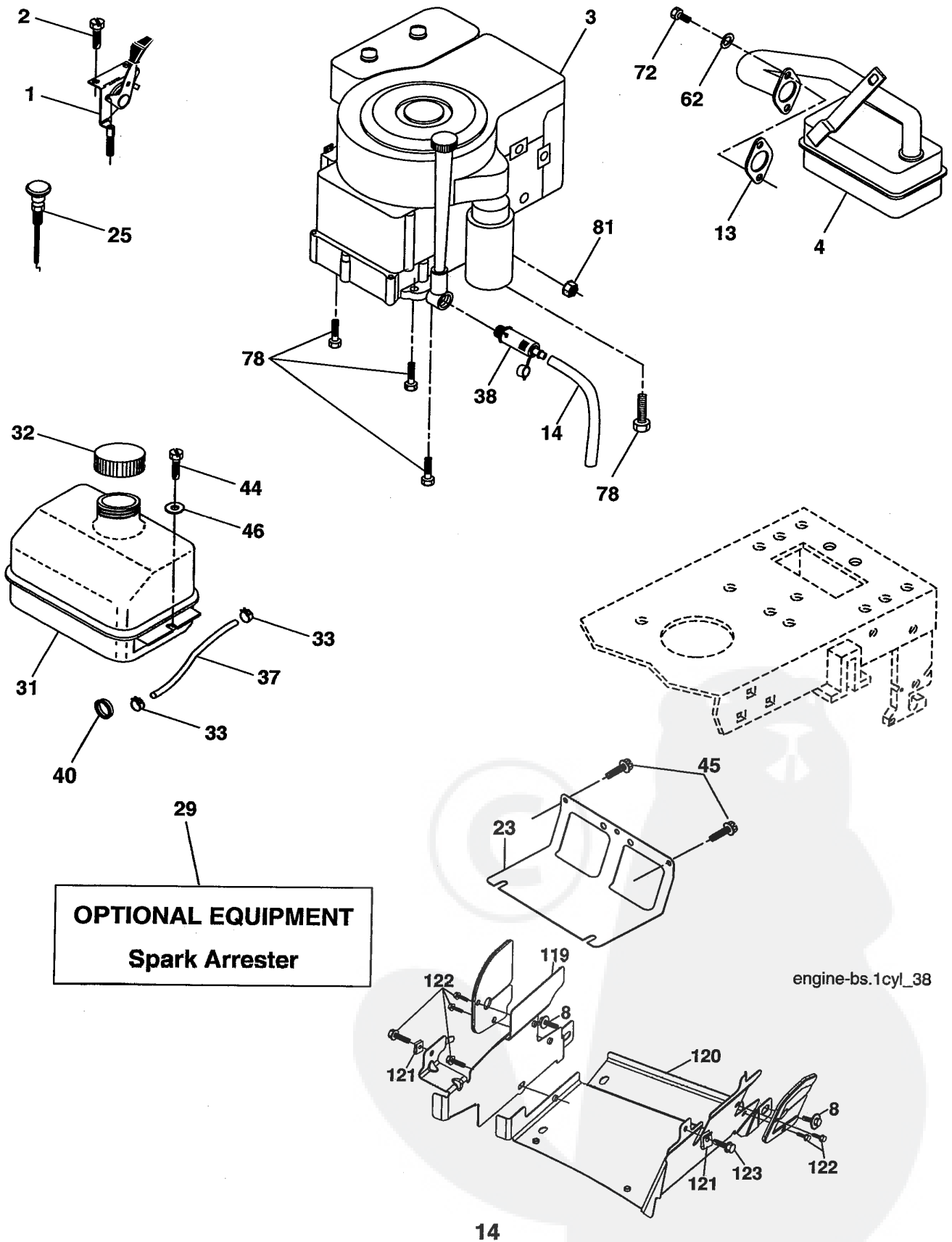

# REPAIR PARTS

TRACTOR - MODEL NO. M155B107HK (96011015400), PRODUCT NO. 960 11 01-54  
ENGINE

KEY NO.	PART NO.	DESCRIPTION
1	532 18 38-97	Control Th/ch Flag
2	532 19 16-11	Screw Hex Thd Cut 1/4-20 x 1/2
3	-----	Engine Briggs & Stratton 282H070 (Order Parts From Engine Manufacturer)
4	532 13 73-52	Muffler LT B&S 12/12.5/13HP
8	532 17 18-77	Bolt 5/16-18 unc x 3/4 w/sems
13	532 16 52-91	Gasket Eng 1 313 Id Tin Plated
14	532 14 84-56	Tube Drain Oil Easy
23	532 16 98-37	Shield Brn/Dbr Guard
25	532 19 59-81	Control Choke 1 Cyl. 02
29	532 13 71-80	Kit Spark Arrestor (Flat Scrn)
31	532 18 77-50	Tank Fuel Front
32	532 19 77-25	Cap Asm Fuel Top
33	532 12 34-87	Clamp Hose Black
37	532 13 70-40	Line Fuel 20"
38	532 18 16-54	Plug Drain Oil Easy
40	532 12 40-28	Bushing Snap Nyl Blk Fuel Line
44	817 67 04-12	Screw Hexwsh Thdrol 1/4-20 x 3/4
45	817 00 06-12	Screw Hex Wsh Thdrol 3/8-16 x 3/4
46	819 09 14-16	Washer 9/32 x 7/8 x 16 Ga.
62	810 01 05-00	Washer Split
72	532 19 23-34	Screw Socket Head 5/16-18 x .75
78	817 06 06-20	Screw 3/8-16x1-1/4
81	873 51 04-00	Nut 1/4-20
119	532 40 05-95	Guard Asm. Eng. LH
120	532 40 05-94	Guard Asm. Eng. RH
121	532 19 66-88	Clips Threaded
122	532 13 77-29	Screw Thd Roll 1/4-20 x 5/8

**NOTE:** All component dimensions given in U.S. inches.  
1 inch = 25.4 mm.





# REPAIR PARTS

TRACTOR - MODEL NO. M155B107HK (96011015400), PRODUCT NO. 960 11 01-54  
MOWER DECK

KEY NO.	PART NO.	DESCRIPTION	KEY NO.	PART NO.	DESCRIPTION
1	532 16 58-92	Deck Asm MWR 42"weldment	102	871 08 10-10	Screw Pan Head Phillip 10-24 x 5/8
2	872 14 05-08	Bolt Rdhd Sqnk 5/16-18 unc x 3/4	103	819 06 12-16	Washer #10
3	532 13 80-17	Bracket Asm Fr Sway Bar 38/42	104	810 07 10-00	Washer Lock #10
4	532 16 54-60	Bracket Asm Deck 42"sway Bar	105	532 16 07-93	Latch Asm. Mulch
5	532 12 46-70	Retainer Spring	106	532 12 50-04	Nut Weld #10-24
6	532 17 80-24	Deck Sway Bar	111	532 17 92-92	Bracket Wheel Gauge LH 42" Deck
8	532 19 30-03	Bolt/Washer Asm. 7/16-20 unf	112	532 17 92-93	Bracket Gauge Wheel RH 42" Deck
11	532 13 41-49	Blade Mower 42"	113	817 00 05-10	Screw Tapping 3/8-16 x .625
13	532 19 28-72	Shaft Asm W/lower Bearing	116	532 12 48-42	Bolt Shoulder
14	532 18 72-81	Housing Mandrel	117	532 18 86-06	Wheel Gauge
15	532 11 04-85	Bearing Ball Mandrel	118	873 93 06-00	Nut Centerlock 3/8-16 UNC
16	532 17 44-93	Stripper Mower	119	819 12 14-14	Washer 3/8 x 7/8 x 14 Ga.
18	872 14 05-05	Bolt Rdhd Sqnk 5/16-18 X 5/8	142	532 19 57-84	Arm Spring Brake Mower
19	532 13 28-27	Bolt Shoulder	143	532 15 71-09	Bracket Arm Idler 42"
20	532 15 97-70	Baffle Vortex 42	144	532 15 86-34	Keeper Belt 42" Clutch
21	873 68 05-00	Nut Crownlock 5/16-18 unc	145	532 16 58-88	Pulley Idler Flat
23	532 17 75-63	Bracket Deflector Mower 42"	146	532 17 19-77	Bolt Carriage Idler
24	532 10 53-04	Cap Sleeve 80x 112 Blk Mower	147	532 17 97-48	Spring Extension
25	532 12 37-13	Spring Torsion Deflector 2 52	148	532 16 90-22	Spring Return Idler
26	532 11 04-52	Nut Push Phos & Oil	149	532 16 58-98	Retainer Spring Yellow
27	532 40 14-31	Shield Deflector Mower 42" Blk	150	819 09 12-10	Washer 9/32 x 3/4 x 10 Ga.
28	819 11 10-16	Washer 11/32 X 5/8 X 16 Ga.	159	872 14 06-14	Bolt Rdhd Sqn 3/8-16 Unc x 1-3/4
29	532 13 14-91	Rod Hinge 42" 6 75 Wlg	184	819 13 14-10	Washer 13/32 x 7/8 x 10 Ga.
30	532 17 39-84	Screw Thd Rolling	196	532 40 11-19	Guard Mandrel rH
31	532 18 76-90	Washer Spacer	199	532 40 02-78	Guard Asm. Fabric 42" LH
32	532 15 35-35	Pulley Mandrel 42"	200	532 40 02-79	Guard Asm. Fabric 42" RH
33	532 40 02-34	Nut Toplock Fling	201	532 40 12-20	Push Nut Round 3/8 Diam
34	872 11 06-12	Bolt Rdhd 3/8-16 unc x1-1/2 Gr. 5	202	872 11 06-08	Bolt Rdhd Sqnk 3/8-16 x 1 Gr. 5
36	532 13 14-94	Pulley Idler Flat 3 060	203	532 19 72-62	Bolt Shoulder
40	873 90 06-00	Nut lock Flg 3/8-16 unc	--	532 19 28-70	Mandrel Assembly(Includes Housing, Shaft and Shaft Hardware Only-Pulley not Included)
44	532 14 00-88	Guard Mandrel LH Black	--	532 40 15-32	Replacement Mower, Complete (order separately mulch cover and gauge wheel components key numbers 101-106 and116-119)
45	532 12 47-88	Spring Retainer 1" Zinc/cad			
46	532 13 77-29	Screw Hex Thd Cut 1/4-20 x 5/8 T			
48	532 13 39-44	Washer Hardened Smaller			
52	532 13 98-88	Bolt Shoulder 5/16-18 unc Blkz			
53	532 18 49-07	Arm Asm Pad Brake			
54	532 17 85-15	Washer Hardened			
55	532 15 50-46	Arm Idler 42"mower LT/YT			
56	532 16 57-23	Spacer Retainer Mower			
59	532 14 10-43	Guard TUV Idler			
68	532 18 02-15	V-Belt Mower 42"			
92	873 80 06-00	Nut Lock Hex W/Ins 3/8-16 unc			
101	532 19 31-07	Cover Mulch 42"			

**NOTE:** All component dimensions given in U.S. inches  
1 inch = 25.4 mm



# REPAIR PARTS

TRACTOR - MODEL NO. M155B107HK (96011015400), PRODUCT NO. 960 11 01-54  
MOWER LIFT

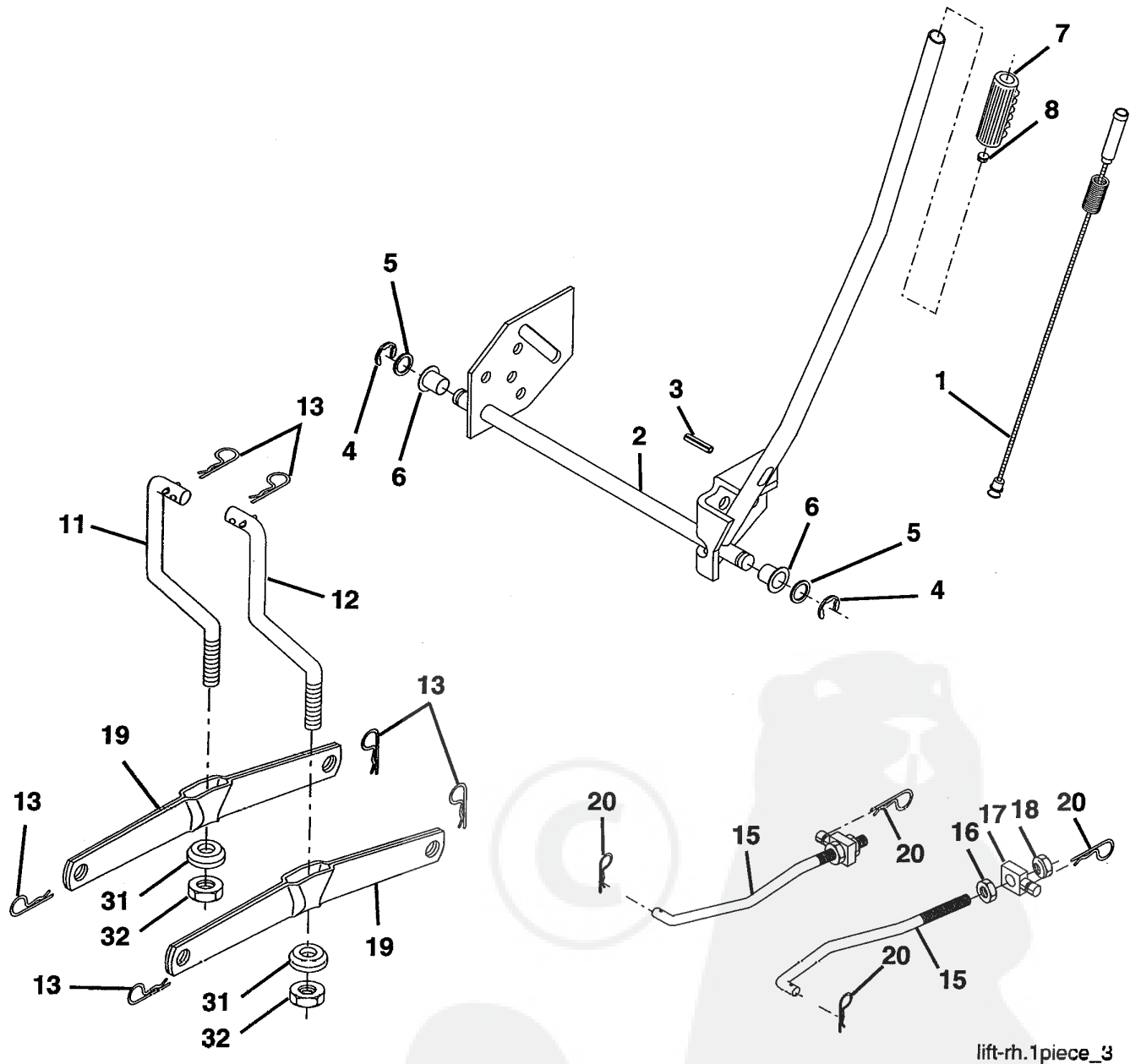

lift-rh.1piece\_3

# REPAIR PARTS

TRACTOR - MODEL NO. M155B107HK (96011015400), PRODUCT NO. 960 11 01-54  
MOWER LIFT

KEY NO.	PART NO.	DESCRIPTION
1	532 19 84-17	Wire Asm Inner W/plunger
2	532 19 80-70	Shaft Asm Lift
3	532 18 88-22	Pin Groove
4	812 00 00-02	E Ring #5133-62
5	819 21 16-21	Washer PLTD 21/32 X 1 X 21ga
6	532 12 01-83	Bearing Nylon Blk 629 Id
7	532 10 94-13	Grip Handle Bicycle
8	532 12 45-26	Button Plunger Black
11	532 13 98-65	Link Lift LH
12	532 13 98-66	Link Lift RH
13	532 12 46-70	Retainer Spring
15	532 17 32-88	Link Front
16	873 35 08-00	Nut Jam Hex 1/2-13 Unc
17	532 17 56-89	Trunnion
18	873 80 08-00	Nut Lock W/Wsh 1/2-13 Unc
19	532 13 98-68	Arm Suspension Rear
20	532 19 42-09	Spring, Retainer
31	532 16 98-65	Bearing Pvt. Lift
32	873 54 06-00	Nut Crownlock 3/8-24

**NOTE:** All component dimensions given in U.S. inches  
1 inch = 25.4 mm

