

REPAIR PARTS MANUAL
MODEL NO. MBA16107BRK
(96061002200)
Lawn Tractor

Mr. Bricolage

532 19 45 71 11.1.04 RD
PRINTED IN U.S.A.

HOW TO USE THIS MANUAL

This manual is designed to provide the customer with a means to identify the parts on his/her tractor when ordering repair parts. The illustrations may or may not represent the actual assemblies; therefore, it is not recommended to use this manual as a guide to assemble or disassemble the tractor. Some hardware and parts are drawn larger in order to more readily identify them.

Each tractor has its own model number.

The model number for your tractor can be found on the fender under the seat.

When ordering parts, always give the following information:

- Product - "Lawn Tractor"
- Model Number - "MBA16107BRK" (96061002200)
- Part Number
- Part Description

TABLE OF CONTENTS

SCHEMATIC	3
ELECTRICAL.....	4-5
CHASSIS AND ENCLOSURES	6-7
DRIVE.....	8-9
STEERING ASSEMBLY.....	10-11
SEAT ASSEMBLY.....	12
DECALS.....	13
ENGINE.....	14-15
LIFT	16-17
MOWER DECK	18-19
BAGGER.....	20-21

**TRACTOR-MODEL NO. MBA16107BRK(96061002200), PRODUCT 960 61 00-22
SCHEMATIC**

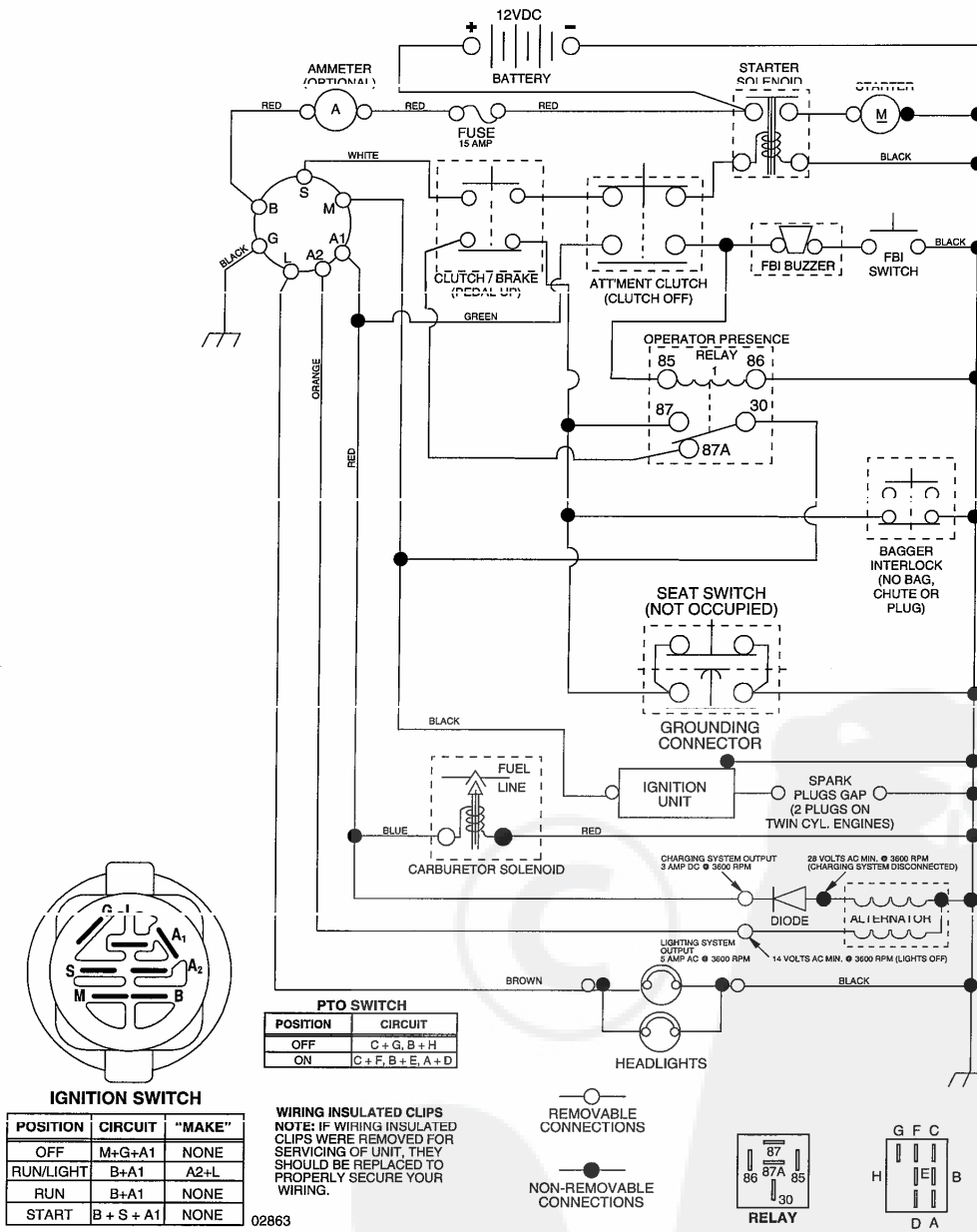

REPAIR PARTS

TRACTOR-MODEL NO. MBA16107BRK(96061002200), PRODUCT 960 61 00-22
ELECTRICAL

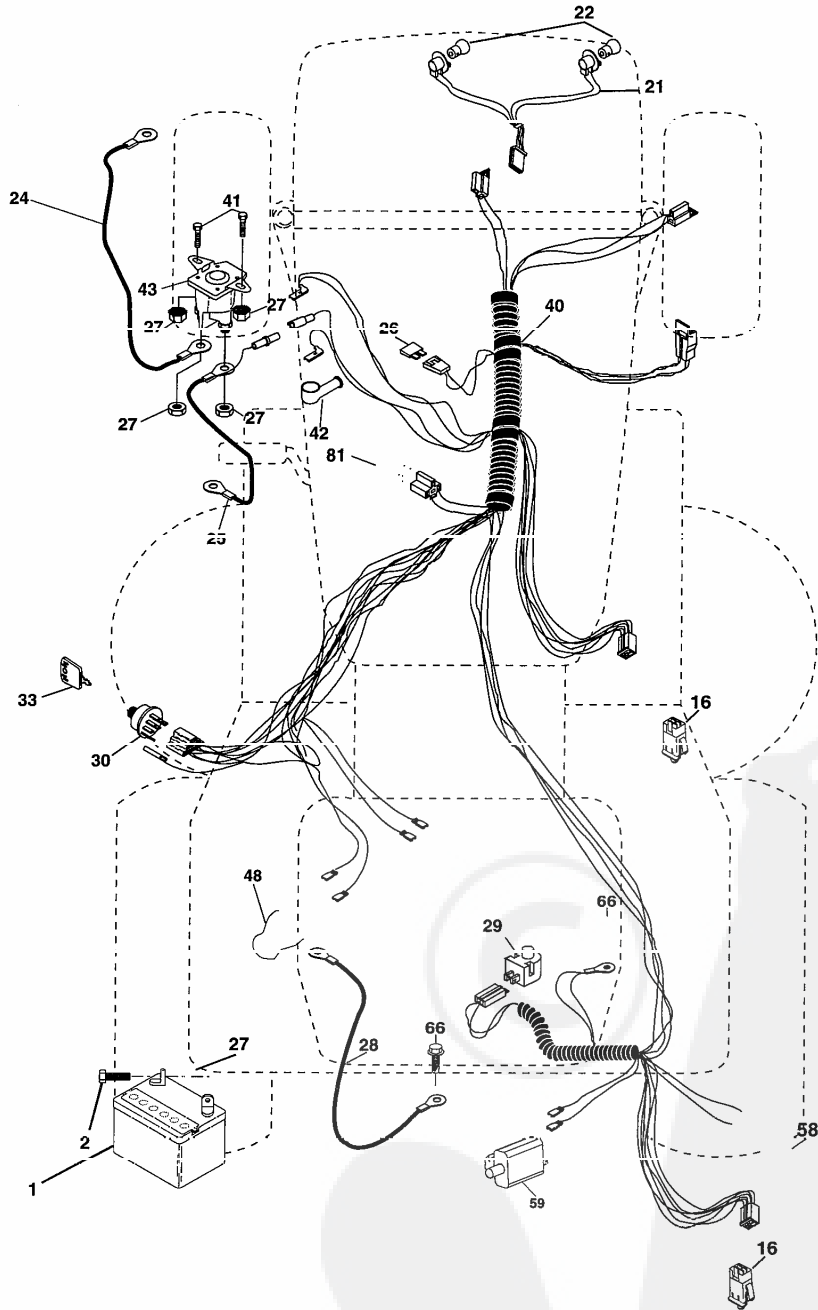

REPAIR PARTS

TRACTOR-MODEL NO. MBA16107BRK(96061002200), PRODUCT 960 61 00-22
ELECTRICAL

KEY NO.	PART NO.	DESCRIPTION
1	532 16 34-65	Battery
2	874 76 04-12	Bolt Hex Hd 1/4-20 unc x 3/4
16	532 17 61-38	Switch Interlock
21	532 18 37-59	Harness Asm Light W/4152J
22	532 00 41-52	Bulb Light #1156
24	532 12 47-80	Cable Battery
25	532 16 59-87	Cable Battery Crd 56" Red
26	532 17 51-58	Fuse
27	873 51 04-00	Nut Keps Hex 1/4-20 unc
28	532 12 77-25	Cable Ground 6 Ga. 18" Black
29	532 12 13-05	Switch Plunger Normal NC Gray
30	532 17 55-66	Switch Ignition
33	532 14 04-01	Key Ign Molded
40	532 18 80-36	Harness Ign
41	871 11 04-08	Bolt Flk Fin Hex 1/4-20 unc x 1/2
42	532 13 15-63	Cover Terminal Red
43	532 17 99 61	Solenoid
48	532 14 08-44	Adapter Ammeter Rectangular
58	532 16 94-19	Buzzer Crd
59	532 18 03-79	Switch FBI CRD
66	817 49 06-08	Screw Thdrol 3/8-16 x 1/2 Ty-Tt
81	532 10 97-48	Relay Asm

NOTE: All component dimensions given in U.S. inches.
1 inch = 25.4 mm.

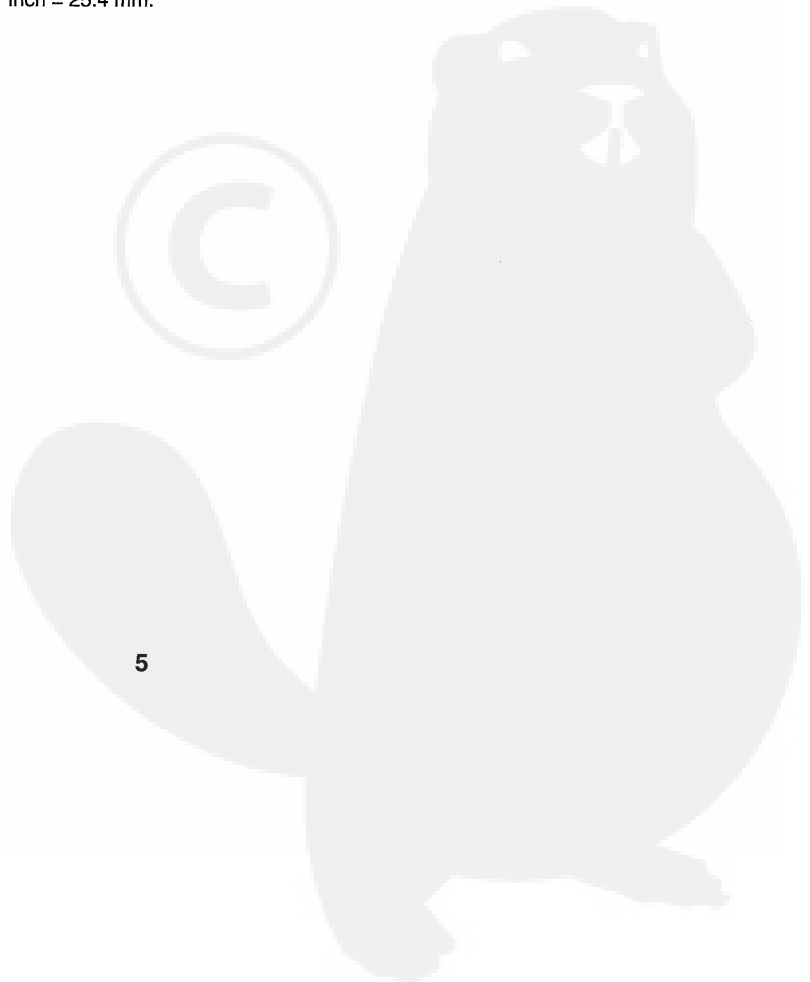
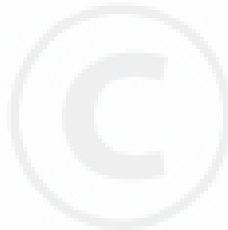

REPAIR PARTS

TRACTOR-MODEL NO. MBA16107BRK(96061002200), PRODUCT 960 61 00-22
CHASSIS AND ENCLOSURES

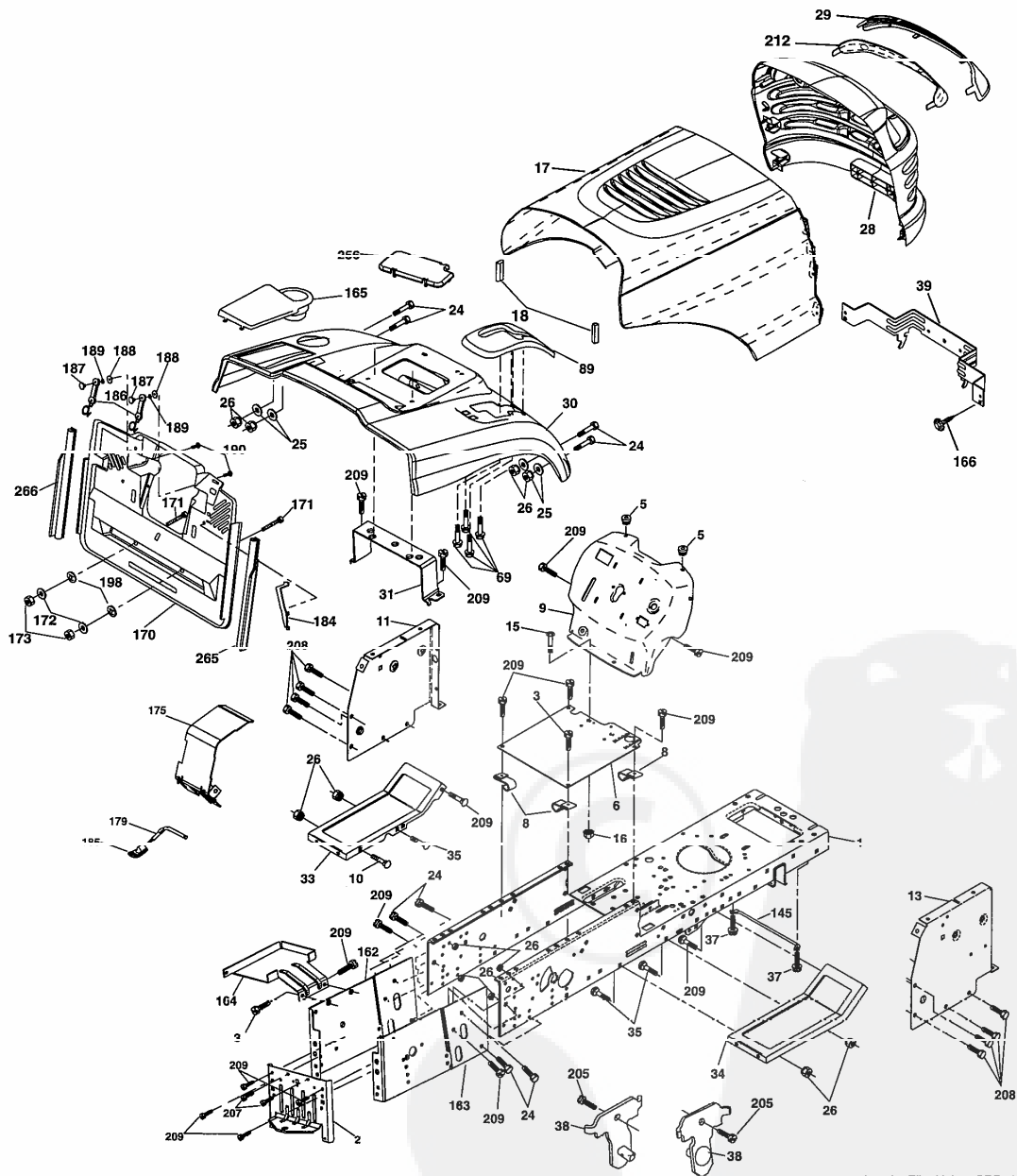

chassis_Elitte Value_CRD_6

REPAIR PARTS

TRACTOR-MODEL NO. MBA16107BRK(96061002200), PRODUCT 960 61 00-22
CHASSIS AND ENCLOSURES

KEY NO.	PAH NO.	DESCRIPTION	KEY NO.	PAH NO.	DESCRIPTION
1	532 17 46-20	Chassis	163	532 18 03-83	Bracket Exten Chassis Rh CRD
2	532 18 03-84	Drawbar	164	532 16 56-05	Support Battery CRD
3	817 06 06-12	Screw 3/8-16 x 3/4	165	532 18 13-56	Cover Battery
5	532 15 52-72	Bumper Hood/Dash	166	532 17 18-75	Screw Hwhd Hi-Lo #13-16 x 5/8
6	532 18 44-19	Saddle	170	532 17 88-62	Backplate Asm CRD
8	532 12 64-71	Clip Insulator 13/32 Mtg. Hole	171	872 14 06-20	Bolt Rdhd Sqnk 3/8-16 x 2-1/2 Gr. 5
9	532 19 46-88	Dash	172	819 13 20-16	Washer 13/32 x 1-1/4 x 16 Ga.
10	872 14 06-08	Boit, Carriage 3/8-16 x 3/4	173	873 51 06-00	Nut, Keps Hex 3/8-16 unc
11	532 17 49-96	Panel, Dash, L.H.	175	532 18 82-03	Guard Trap
13	532 18 69-52	Panel, Asm. Dash R.H.	179	532 18 82-02	Rod Pivot FBI CRD
15	874 18 05-12	Screw, Machine, Truss Head 5/16-18 unc x 3/4	184	532 17 46-62	Bracket Actuator Bagger CRD
16	873 51 05-00	Nut	185	532 18 11-01	Knob Rod Brake Parking
17	532 19 00-85	Hood	186	532 16 07-93	Latch Asm Mulch/Bagger
18	532 12 69-38	Bumper Hood	187	532 12 50-04	Nut Weld
24	874 78 06-16	Bolt	188	819 06 12-16	Washer #10
25	819 13 13-12	Washer 13/32 x 13/16 x 12 Ga.	189	810 07 10-00	Washer Lock #10
26	873 80 06-00	Nut	190	871 08 10-10	Screw Pan Hd Phillip 10-24 x 5/8
28	532 18 35-52	Grille /Lens Asm (Inc. Key #'s 29, 212)	198	532 16 89-37	Nut, Push
29	532 18 58-46	Lens, Grille	205	817 49 06-08	Screw Thdrol 3/8-16 x 1/2
30	532 18 55-50	Fender	207	817 67 05-08	Screw Thdrol 5/16-18 x 1/2
31	532 16 51-56	Bracket, Fender Support	208	817 67 06-08	Screw Thdrol 3/8-16 x 1/2
33	532 18 55-45	Footrest, L.H.	209	817 00 06-12	Screw Hex Wsh Thdrol 3/8-16
34	532 18 55-46	Footrest, R.H.	212	532 18 35-50	Insert Lens Reflective
35	872 11 06-06	Bolt	256	532 18 13-61	Cover Fender Rack CRD
37	817 49 05-08	Screw Thdrol 5/16-18 x 1/2 TYT	265	532 18 57-04	Seal RH Side Bagger
38	532 18 17-48	Bracket Asm Pivot Mower Rear	266	532 18 57-03	Seal LH Side Bagger
39	532 17 47-14	Bracket Pivot	--	532 00 54-79	Plug, Button
69	532 14 24-32	Screw Hex Wsh	--	532 19 39-35	Plug, Switch Light
89	532 18 13-88	Console			
145	532 15 65-24	Rod Pivot Chassis/Hood			
162	532 18 03-82	Bracket Exten Chassis Lh CRD			

NOTE: All component dimensions given in U.S. inches.
1 inch = 25.4 mm.

REPAIR PARTS

TRACTOR-MODEL NO. MBA16107BRK(96061002200), PRODUCT 960 61 00-22
DRIVE

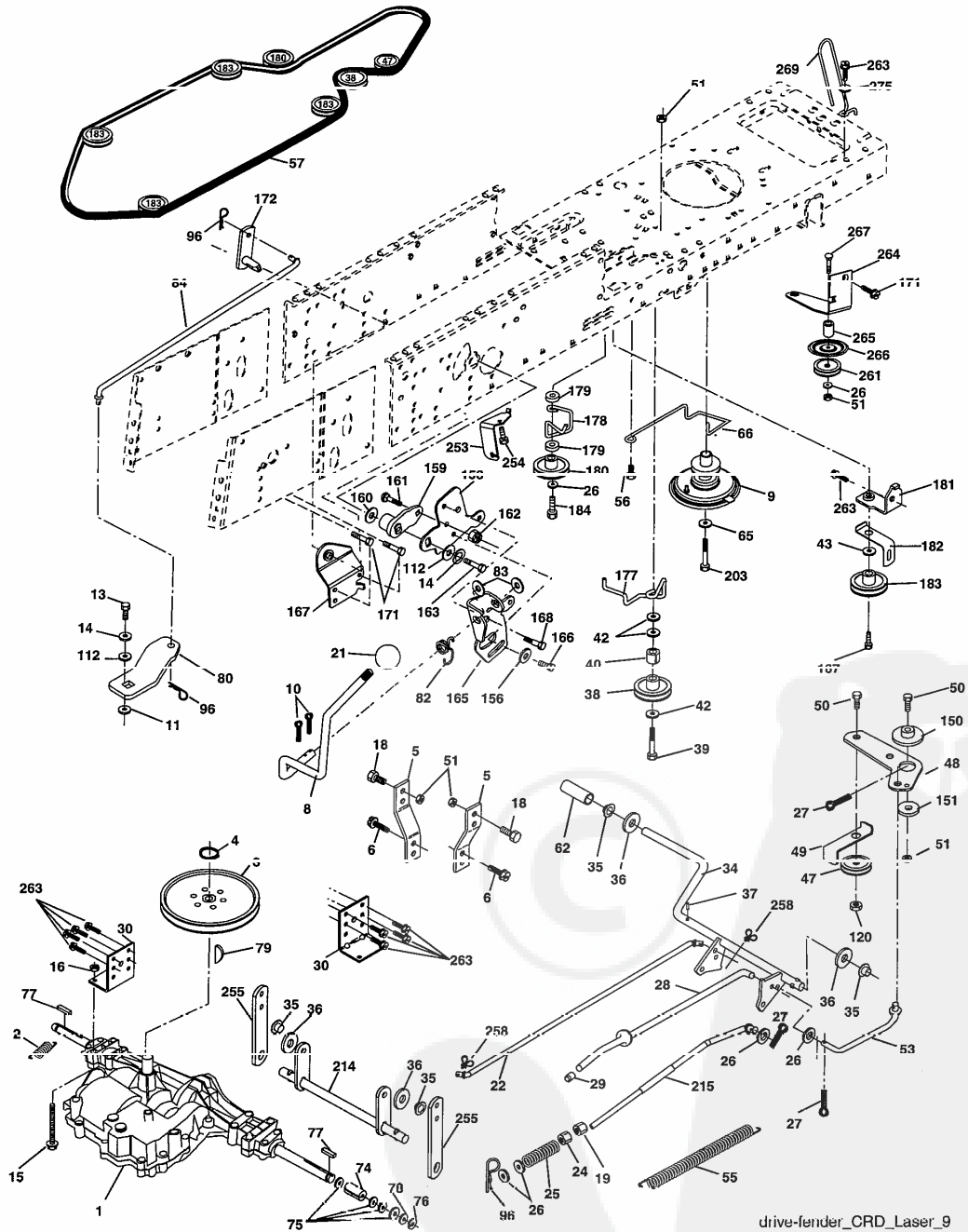

drive-fender_CRD_Laser_9

REPAIR PARTS

TRACTOR-MODEL NO. MBA16107BRK(96061002200), PRODUCT 960 61 00-22
DRIVE

KEY NO	PART NO	DESCRIPTION	KEY NO	PART NO	DESCRIPTION
1	-----	Transaxle Peerless 206-546 (Order parts from transaxle manufacturer)	78	532 12 17-48	Washer 25/32 x 1-5/8 x 16 Ga.
2	532 14 66-82	Spring Brake Return	79	532 12 50-96	Key Woodruff
3	532 16 59-99	Pulley Transaxle	80	532 14 50-90	Arm Shift PMST 20" Tires
4	812 00 00-28	Ring Retainer #5100-62	82	532 16 57-11	Spring, Torsion
5	532 12 15-20	Strap torque 30 degrees	83	819 17 12-16	Washer 17/32 x 3/4 x 16 Ga.
6	817 06 05-12	Screw 5/16-18 x 3/4	84	532 16 56-21	Link Shift CRD Pmst 18" Tires
8	532 16 56-19	Rod Shift Fender Adjust Lt	96	532 12 47-88	Spring, Retainer 1"
9	532 18 03-54	Clutch Asm Noram	112	819 09 12-10	Washer 9/32 x 3/4 x 10 Ga.
10	876 02 04-16	Pin, Cotter 1/8 x 1	120	873 90 06-00	Nut Lock Flg. 3/8-16 unc
11	532 10 57-01	Washer Plate Shf .3888 sq hole	150	532 16 58-50	Bushing, Bellcrank Grnd Dr
13	874 55 04-12	Bolt 1/4-28 unf Gr. 8 w/patch	151	819 13 32-10	Washer 13/32 x 2 x 10 Ga.
14	810 04 04-00	Washer, Lock Hvy Helical	156	532 16 60-02	Washer Srrd 5/16 ID x 1.125
15	874 49 05-44	Bolt Hex FGHD 5/16-18 x Gr. 5	158	532 16 55-89	Bracket Shift Mount
16	873 80 05-00	Nut, Lock Hex w/lms 5/16-18 unc	159	532 18 39-00	Hub Shift
18	874 78 06-16	Bolt Hex 3/8-16 unc x 1 Gr. 5	160	819 29 20-16	Washer 29/32 x 1-1/4 x 16 Ga.
19	873 80 06-00	Nut, Lock Hex w/Wsh 3/8-16 unc	161	872 14 04-06	Bolt Rdhd Sqnk 1/4-20 x 3/4 Gr. 5
21	532 18 03-33	Knob Rd 1/2-13 Flstc Thds Dik	162	873 68 04-00	Nut Crownlock 1/4-20 unc
22	532 17 56-07	Rod, Brake CRD	163	874 78 04-16	Bolt Hex Fin 1/4-20 unc x 1 Gr. 5
24	873 35 06-00	Nut	165	532 18 50-25	Bracket Pivot Lever
25	532 10 68-88	Spring, Rod, Brake	166	817 49 05-10	Screw 5/16-18 x 5/8
26	819 13 13-16	Washer 13/32 x 13/16 x 16 Ga.	167	532 16 55-88	Bracket Support Shift CRD
27	876 02 04-12	Pin, Cotter 1/8 x 3/4	168	532 16 54-92	Bolt Shoulder 5/16-18 x .561
28	532 17 57-65	Rod, Parking Brake	171	817 49 06-08	Screw Thdrol 3/8-16 x 1/2 Ty-Tt
29	532 07 16-73	Cap, Parking Brake	172	532 16 56-35	Shaft Asm Shift Front CRD PMST
30	532 17 49-73	Bracket, Mfg. Transaxle	177	532 16 59-32	Keeper Flat Idler 3.06" CRD
34	532 17 55-78	Shaft, Asm Pedal Foot	178	532 16 59-33	Keeper Belt Idler 1.88" CRD
35	532 12 01-83	Bearing, Nylon	179	532 12 09-58	Washer Sintered
36	819 21 16-16	Washer 21/32 x 1 x 16 Ga.	180	532 16 56-30	Pulley Flat Idler
37	532 12 49-63	Pin, Roll 3/16 x 1"	181	532 18 02-11	Bracket Idler Ground Drive CRD
38	532 16 59-36	Pulley, Flat	182	532 18 26-82	Keeper Belt 2.5" Od V-Idler CRD
39	874 76 06-44	Bolt Fin Hex 3/8-16 unc x 2-3/4	183	532 18 60-07	Pulley V-Idler
40	532 12 49-65	Spacer, Split 395 x 59 Bzp	184	817 49 06-44	Screw Hexwsh Thdrol 3/8-16 x 2-3/4
42	819 13 13-12	Washer 13/32 x 13/16 x 12 Ga.	187	817 58 05-20	Screw thdrol 5/16-18 x 1 1/4
43	819 11 10-12	Washer 11/32 x 5/8 x 12 Ga.	203	871 17 07-80	Bolt Hex 7/16-20 x 5
47	532 12 77-83	Pulley, Idler, V Groove Plstic	214	532 17 56-09	Shaft Asm Blade
48	532 15 44-07	Bellcrank Clutch Grnd Drv	215	532 17 56-51	Rod Brake Secondary
49	532 12 32-05	Retainer, Belt Style Spring	253	532 17 50-28	Bracket Cable Chassis
50	872 11 06-12	Bolt Carr. Sh. 3/8-16 x 1-1/2 Gr. 5	254	817 00 06-16	Screw 3/8-16 x 1
51	873 68 06-00	Nut, Crownlock 3/8-16 unc	255	532 17 56-08	Brace Shaft Brake Mtg.
53	532 10 57-10	Link, Clutch 7.66	258	532 17 80-62	Clip Retainer
55	532 10 57-09	Spring, Return, Clutch	261	532 13 14-94	Pulley Idler
56	817 06 06-20	Screw 3/8-16 x 1-1/4	263	817 00 06-12	Screw Hex Wsh Thdrol 3/8-16 x 3/4
57	532 16 56-31	V-Belt Kev PMST CRD	264	532 18 19-95	Bracket Clutch Mtg
62	532 12 48-72	Cover, Pedal	265	532 18 20-13	Spacer Idler Chassis
65	810 04 07-00	Washer	266	532 18 20-61	Shield Idler Mower
66	532 15 47 79	Keeper, Belt Engine F Proof	267	972 14 06 25	Bolt 3/8 16 x 3 1/4
74	532 13 70-57	Spacer Axle	269	532 18 24-02	Guard Muffler
75	532 12 17-49	Washer 25/32 x 1-1/4 x 16 Ga.	275	819 13 16-14	Washer 13/32 x 1 x 14 Ga.
76	812 00 00-01	Ring, E			
77	532 12 35-83	Key, Square			

NOTE: All component dimensions given in U.S. inches
1 inch = 25.4 mm

REPAIR PARTS

TRACTOR-MODEL NO. MBA16107BRK(96061002200), PRODUCT 960 61 00-22
STEERING ASSEMBLY

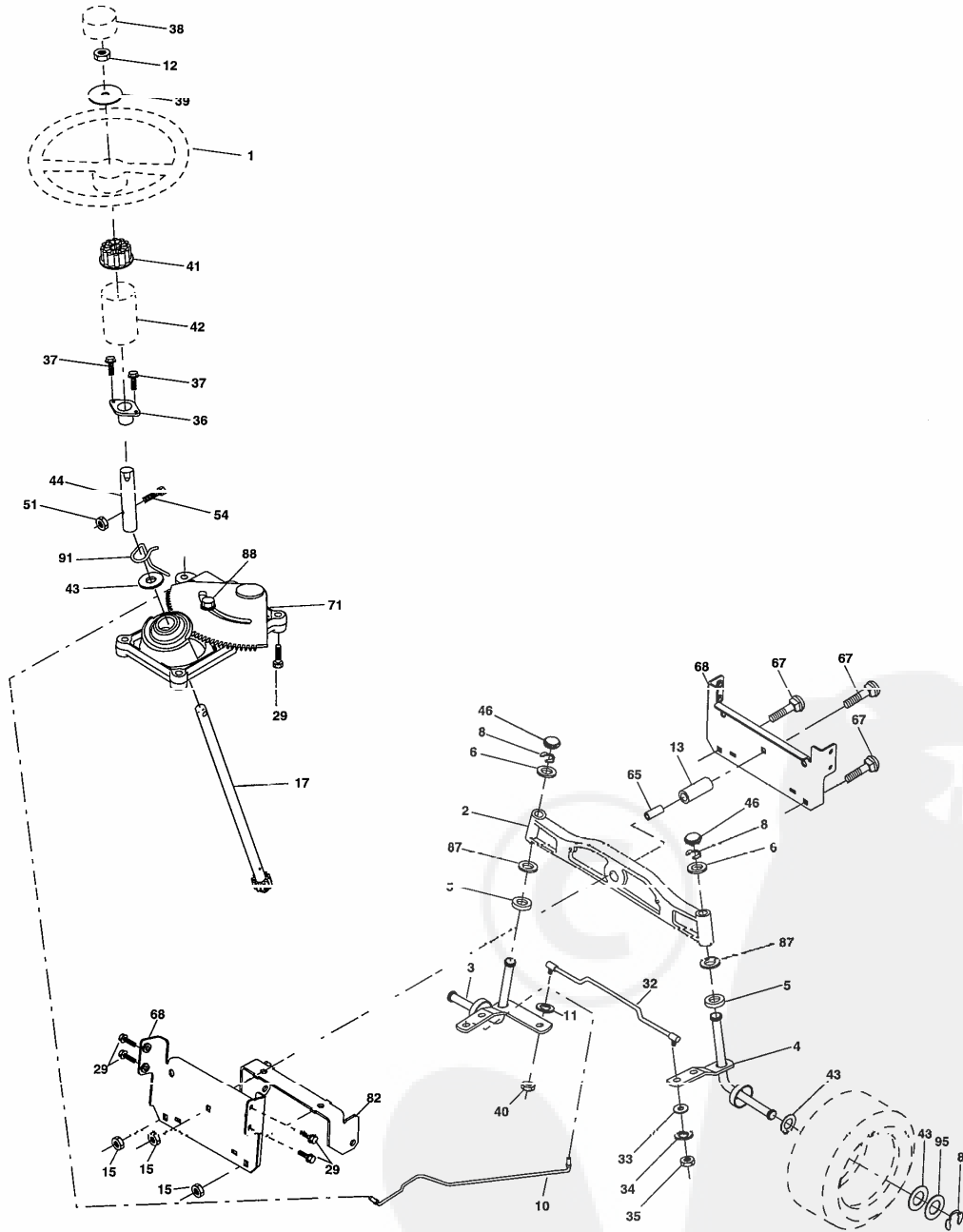

steering_pl.it_29

REPAIR PARTS

TRACTOR-MODEL NO. MBA16107BRK(96061002200), PRODUCT 960 61 00-22
STEERING ASSEMBLY

KEY NO.	PART NO.	DESCRIPTION
1	532 18 67-80	Steering Wheel
2	532 18 47-06	Axle Asm
3	532 16 98-40	Spindle Assembly, L.H.
4	532 16 98-39	Spindle Assembly, R.H.
5	532 12 49-31	Washer, Thrust .75 x 1.230
6	532 12 17-48	Washer 25/32 x 1-5/8 x 16 Ga.
8	812 00 00-29	Ring, Klip
10	532 17 51-21	Link, Drag
11	810 04 06-00	Washer, Lock
12	873 94 08-00	Nut Hex Jam Toplock 1/2-20 unf
13	532 13 65-18	Spacer Brg Axle Front
15	532 14 52-12	Nut, Hex Flange Lock
17	532 18 06-41	Shaft Assembly, Steering
29	817 00 06-12	Screw 3/8-16 x 3/4
32	532 17 01-62	Rod, Tie
33	819 11 12-16	Washer 11/32 x 3/4 x 16 Ga.
34	810 04 05-00	Washer Lock Hvy Hlcl Spr 5/16
35	873 54 05-00	Crownlock Nut 5/16-24 unf
36	532 15 50-00	Pushing, Steering
37	532 15 29-27	Screw TT #10-32 x 5 x 3/8 Flange
38	532 19 29-16	Cap Wheel Steering
39	819 18 38-12	Washer 9/16 ID X 2-3/8 OD 12 G.
40	873 54 06-00	Nut Crownlock 3/8-24
41	532 18 67-37	Adaptor, Steering Wheel
42	532 16 96-33	Boot, Steering Dash P/L Mtl
43	532 12 17-49	Washer 25/32 x 1-1/4 x 16 Ga.
44	532 18 06-40	Extension Steering
46	532 12 12-32	Cap, Spindle
51	873 54 04-00	Nut Crownlock 1/4-28
54	871 13 04-20	Bolt Hex 1/4-28 unf x 1-1/4 Gr. 8
65	532 16 03-67	Spacer Brace Axle
67	872 11 06-18	Bolt Rdhd Sq 3/8-16 x 2-1/4
68	532 16 98-27	Brace Axle
71	532 17 51-46	Steering Asm.
82	532 16 98-35	Bracket Susp Chassis Front 15"
87	532 17 39-66	Washer Flat .781 x 1-1/2 x .14
88	532 17 51-18	Bolt Shoulder 7/16-20 unc
91	532 17 55-53	Clip Steering
95	532 18 89-67	Washer Hardened

NOTE: All component dimensions given in U.S. inches.
1 inch = 25.4 mm.

REPAIR PARTS

TRACTOR-MODEL NO. MBA16107BRK(96061002200), PRODUCT 960 61 00-22
SEAT ASSEMBLY

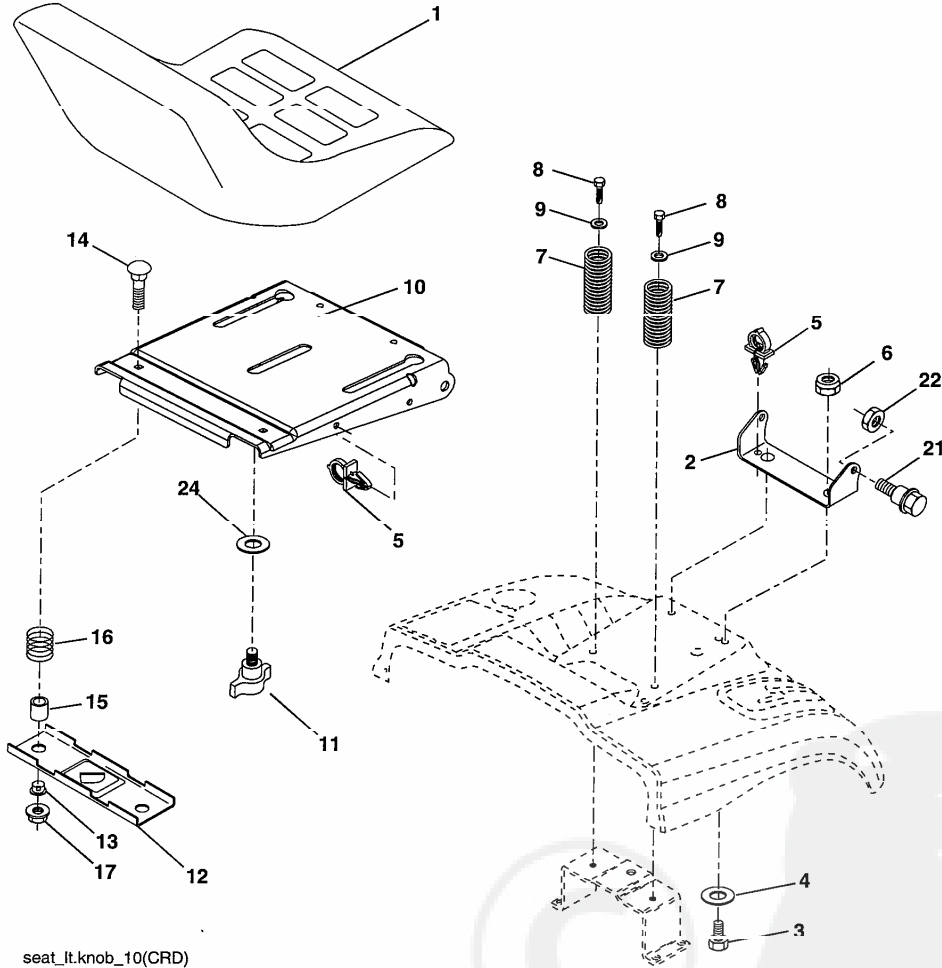

seat_lt.knob_10(CRD)

KEY NO.	PART NO.	DESCRIPTION
1	532 18 87-05	Seat
2	532 18 01-66	Bracket Pivot Seat
3	871 11 06-16	Bolt Fin Hex 3/8-16 unc x 1
4	819 13 16-10	Washer Flat 13/32 x 1 x 10 Ga.
5	532 14 50-06	Cirp Push in Hinged
6	873 80 06-00	Nut Lock Hex w/Ins 3/8-16 unc
7	532 12 41-81	Spring Seat Cprsn 2 250 Blk Zi
8	817 00 06-16	Screw 3/8-16 x 1-1/2
9	819 13 16-14	Washer 13/32 x 1 x 14 Ga.
10	532 18 01-86	Pan Assembly Seat
11	532 16 63-69	Knob Seat Adj. Wingnut
12	532 12 12-46	Bracket Pnt Mounting Switch

KEY NO.	PART NO.	DESCRIPTION
13	532 12 12-48	Bushing Snap Blk Nyl 50 Id
14	872 05 04-12	Bolt Rdhd Sht Nk 1/4-20 x 1-1/2
15	532 13 43-00	Spacer Split
16	532 12 12-50	Spring Cprsn
17	532 12 39-76	Nut Lock 1/4 Lge Fig Gr. 5 Zinc
21	532 17 18-52	Bolt Shoulder 5/16-18 unc-2A
22	873 80 05-00	Nut Hex Lock w/Ins 5/16-18
24	819 17 19-12	Washer 17/32 x 1-3/16 x 12 Ga.

NOTE: All component dimensions given in U.S. inches.
1 inch = 25.4 mm

REPAIR PARTS

TRACTOR-MODEL NO. MBA16107BRK(96061002200), PRODUCT 960 61 00-22
DECALS

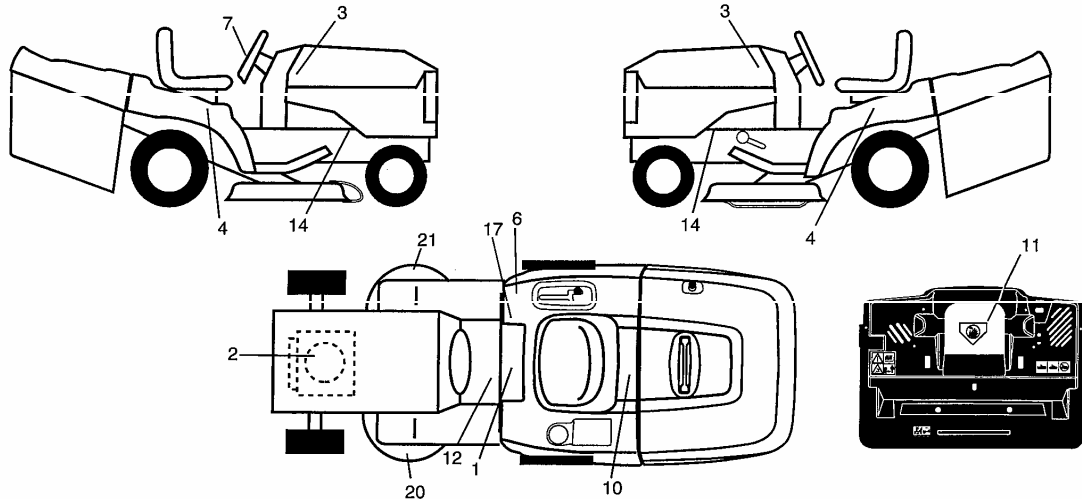

KEY NO.	PART NO.	DESCRIPTION
1	532 14 54-98	Decal Read Owner's Manual Sym
2	532 18 96-83	Decal Hp Engine
3	532 17 16-68	Decal Hood
4	532 19 42-05	Decal Fender
6	532 18 04-32	Decal 100 DBA/CE
7	532 16 79-70	Decal Ins Strg Whl
10	532 14 50-05	Decal Bat Dan/Poi P/L Sym Wpr
11	532 18 21-66	Decal Mower Cut Finger Symbol
12	532 15 97-37	Decal Brake/Clutch Symbol Lt
14	532 15 97-36	Decal Chassis Hot Muffler

KEY NO.	PART NO.	DESCRIPTION
17	532 14 08-37	Decal Saddle Brake Parking
20	532 18 78-11	Decal Enviro Deck
21	532 16 62-86	Decal Deck Sch
—	532 18 26-21	Decal Bagger Frame
—	532 13 83-11	Decal Lift Handle
—	532 19 33-59	Manual Operator's (Euro)
—	532 19 45-71	Manual Parts

WHEELS & TIRES

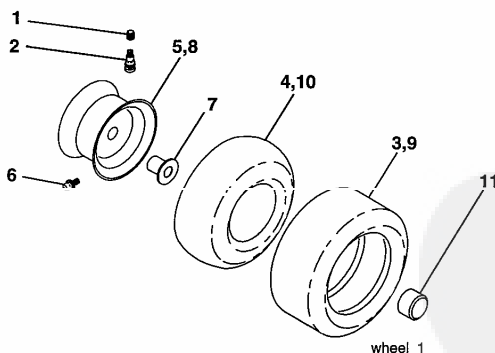

KEY NO.	PART NO.	DESCRIPTION
1	532 05 91-92	Cap Value Tire
2	532 06 51-39	Stem Valve
3	532 12 41-57	Tire F Ts 15 x 6 0 - 6 Service
4	532 05 99-04	Tube Inner Front #35060
5	532 18 33-37	Rim Asm 6" front Service
6	532 12 49-57	Fitting Grease
7	532 12 49-59	Bearing Flange
8	532 18 33-38	Rim Asm 8" rear Service
9	532 12 39-69	Tire R Ts 18 x 8.5-8 Service
10	532 12 49-26	Tube Rear 9 5 x 8 Service
11	532 17 50-39	Cap Axle Blk 1 50 x 1 00
--	532 14 43-34	Sealant, Tire (10 oz. tube)

NOTE: All component dimensions given in U.S. inches
1 inch = 25.4 mm

REPAIR PARTS

TRACTOR-MODEL NO. MBA16107BRK(96061002200), PRODUCT 960 61 00-22
ENGINE

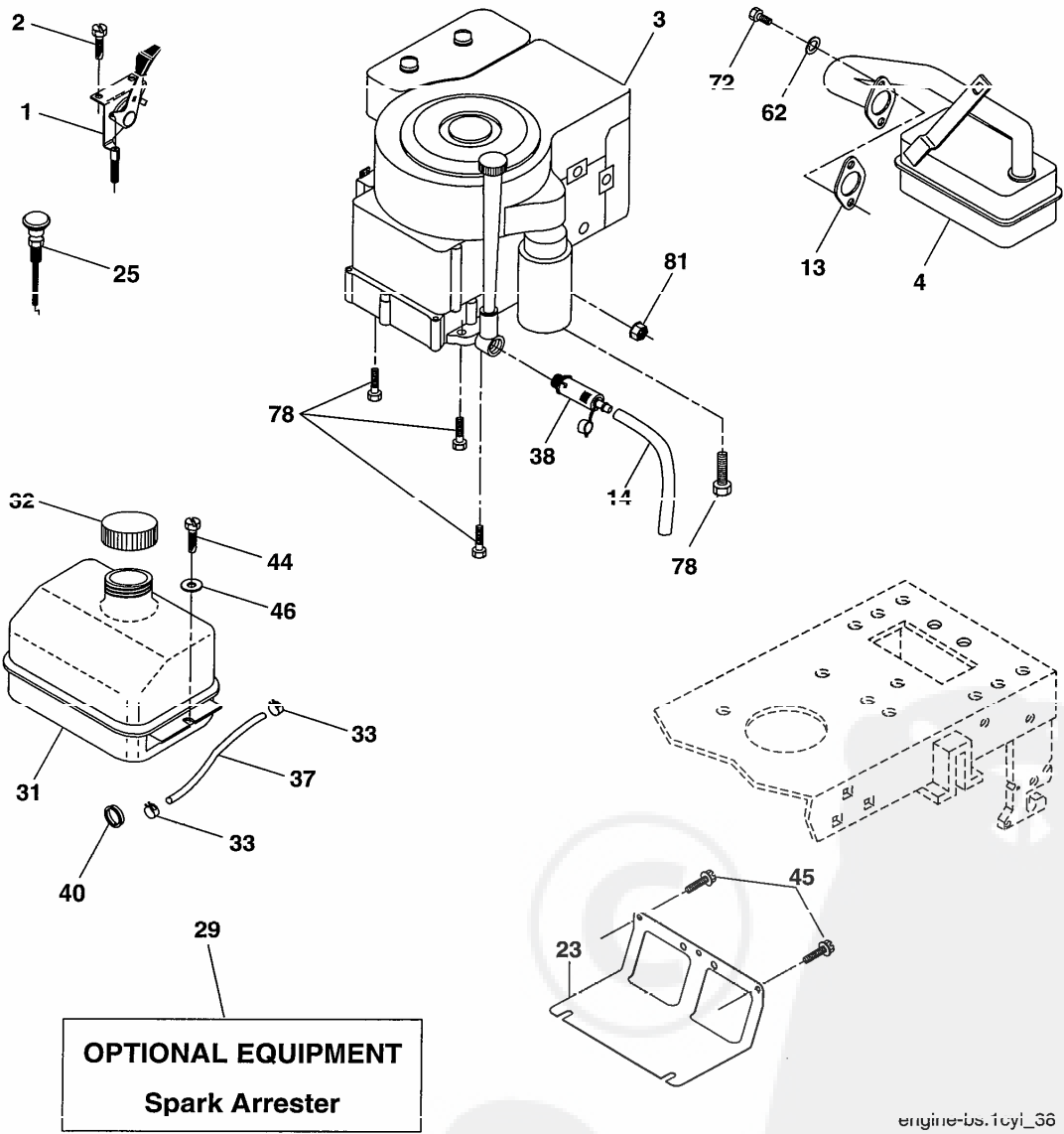

engine-us.tcyi_36

REPAIR PARTS

TRACTOR-MODEL NO. MBA16107BRK(96061002200), PRODUCT 960 61 00-22
ENGINE

KEY NO.	PART NO.	DESCRIPTION
1	532 17 05-51	Control Throt /Ch
2	817 72 04-08	Screw Hex Thd Cut 1/4-20 x 1/2
3	-----	Engine Briggs Model 283H07 (Order Parts from Engine Manufacturer)
4	532 13 73-52	Muffler
13	532 16 52-91	Gasket 1 3/16 Id Tin Plated
14	532 14 84-56	Tube Oil Drain
23	532 16 98-37	Shield Browning/Debris Guard
25	532 19 06-95	Control Choke
29	532 13 71-80	Arrestor Spark
31	532 18 77-50	Tank Fuel
32	532 14 05-27	Cap Asm Fuel
33	532 12 34-87	Clamp Hose Blk
37	532 13 70-40	Line Fuel 20"
38	532 18 16-54	Oil Drain
40	532 12 40-26	Bushing Snap
44	817 67 04-12	Screw Hexwsh Thdrol 1/4-20 x 3/4
45	817 00 06-12	Screw Hexwsh Thdrol 3/8-16 x 3/4
46	819 09 14-16	Washer 9/32 x 7/8 x 16 Ga.
62	810 01 05-00	Washer Split
72	871 07 05-12	Screw 5/16-18 x 3/4
78	817 06 06-20	Screw 3/8-16 x 1-1/4
81	873 51 04-00	Nut Keps Hex 1/4-20 unc

NOTE: All component dimensions given in U.S. inches
1 inch = 25.4 mm

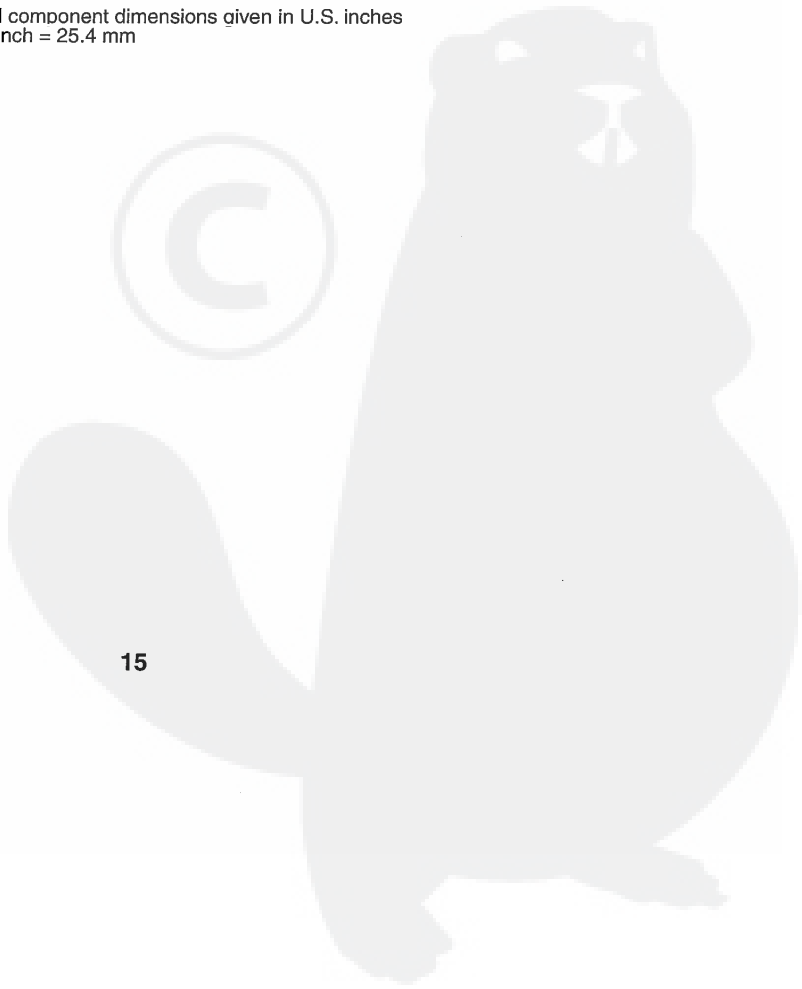
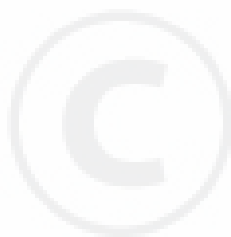

REPAIR PARTS

TRACTOR-MODEL NO. MBA16107BRK(96061002200), PRODUCT 960 61 00-22
MOWER LIFT

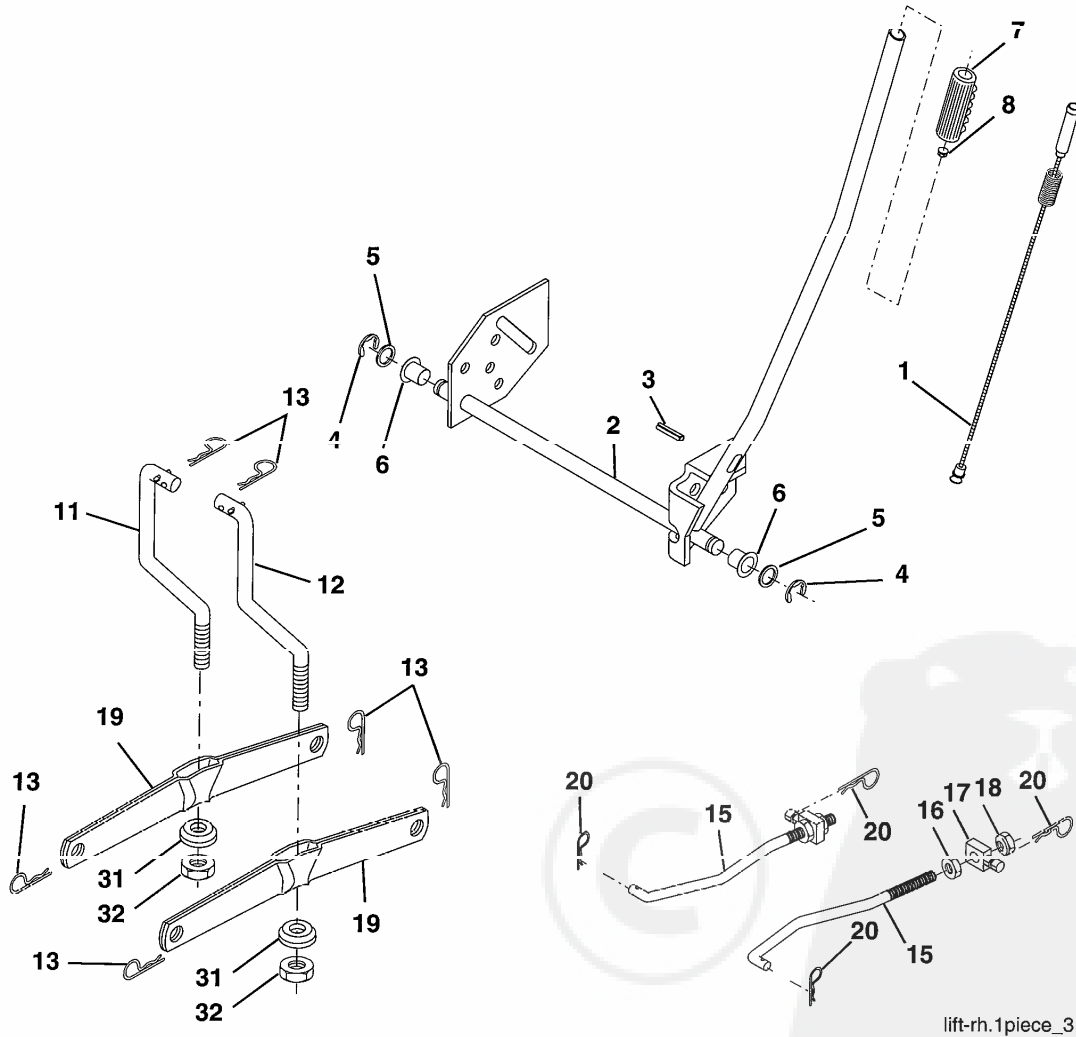

lift-rh.1piece_3

REPAIR PARTS

TRACTOR-MODEL NO. MBA16107BRK(96061002200), PRODUCT 960 61 00-22
MOWER LIFT

KEY NO.	PART NO.	DESCRIPTION
1	532 15 94-61	Washer Asm Inner Spring W/Plunger
2	532 15 94-76	Shaft Asm. Lift
3	532 17 89-81	Pin Groove
4	812 00 00-02	E Ring #5133-62
5	819 21 16-21	Washer 21/32 x 1 x 21 Ga.
6	532 12 01-83	Bearing Nylon
7	532 10 94-13	Grip Handle
8	532 12 45-26	Button Plunger Black
11	532 16 58-29	Link Asm Lift L.H.
12	532 16 58-31	Link Asm Lift R.H.
13	532 12 46-70	Retainer Spring
15	532 17 32-88	Link Front
16	873 35 08-00	Nut Jam Hex 1/2-13 unc
17	532 17 56-89	Trunnion
18	873 80 08-00	Nut Lock w/Wsh 1/2-13 unc
19	532 13 98-68	Arm Suspension mower
20	532 16 35-52	Retainer Spring
31	532 16 98-65	Bearing, Pvt. Lift.
32	873 54 06-00	Nut Crownlock 3/8-24

NOTE: All component dimensions given in U.S. inches
1 inch = 25.4 mm

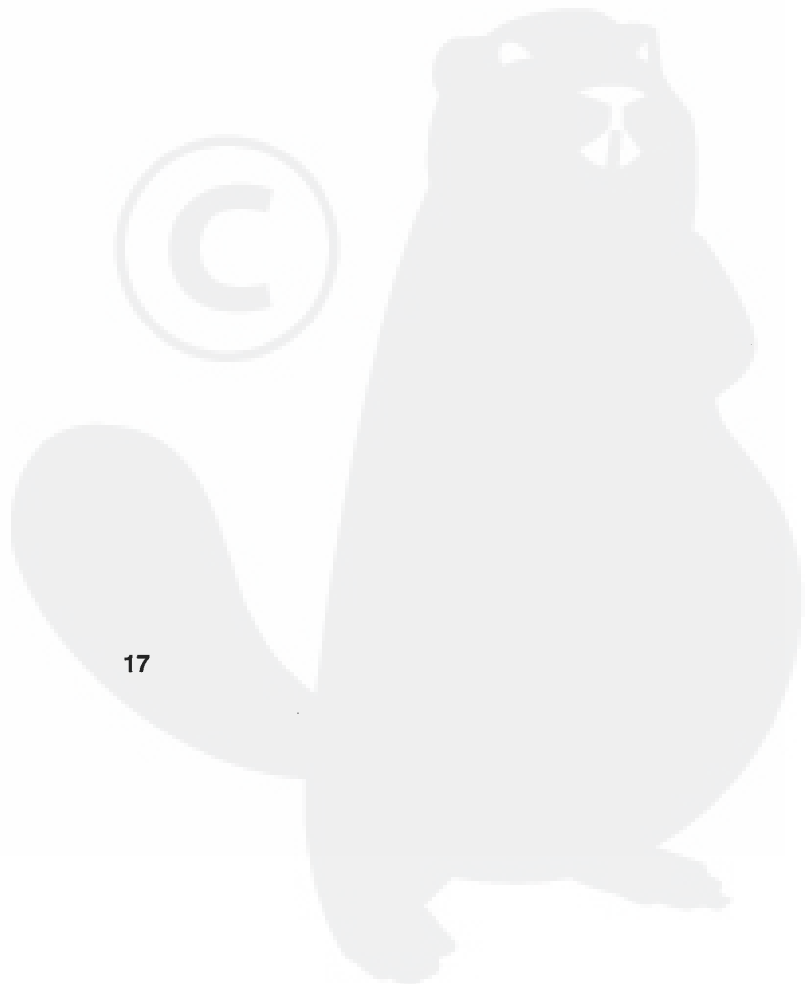
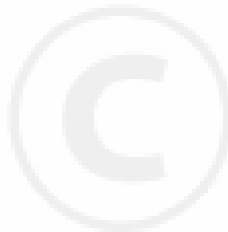

REPAIR PARTS

TRACTOR-MODEL NO. MBA16107BRK(96061002200), PRODUCT 960 61 00-22
MOWER

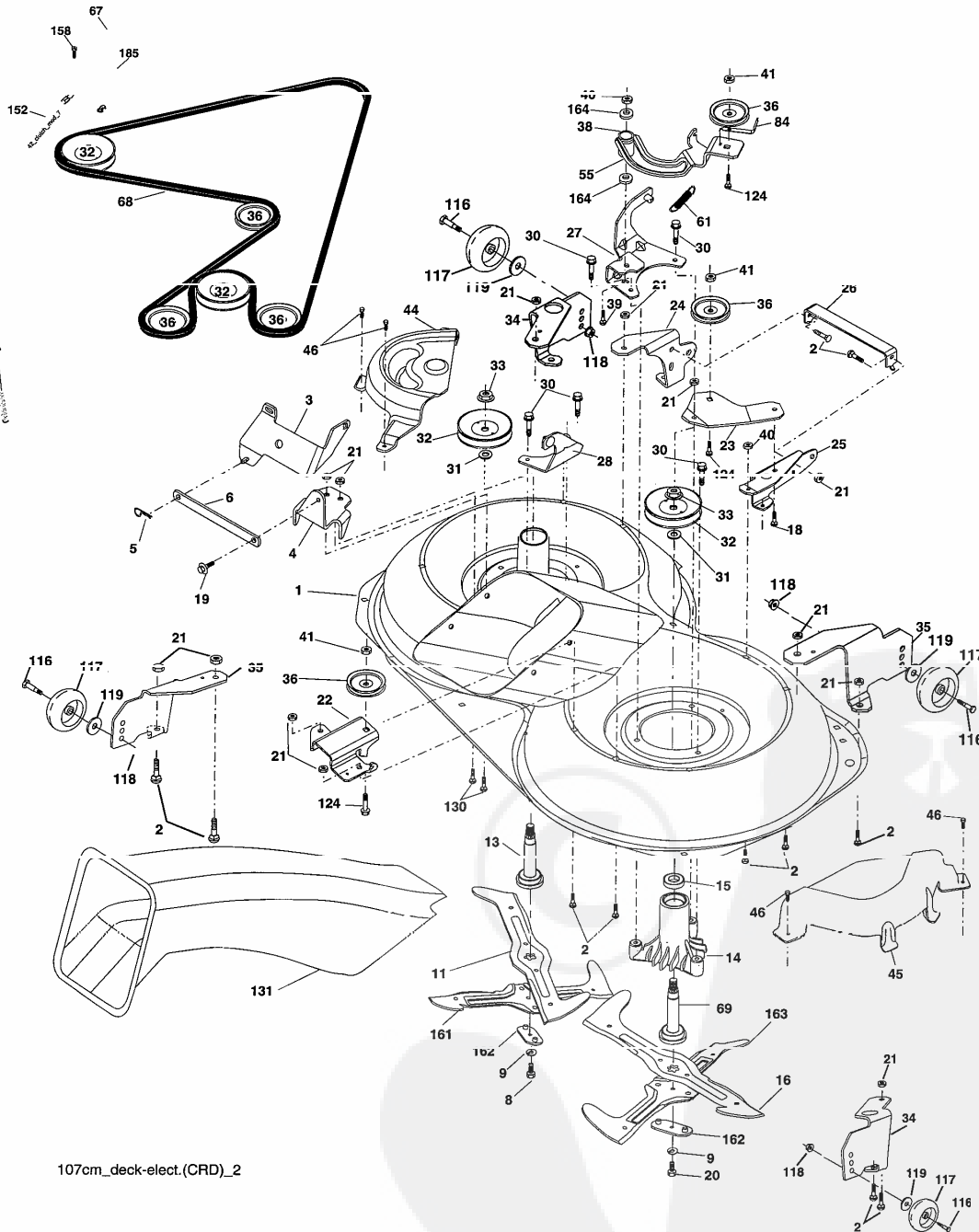

107cm_deck-elect.(CRD)_2

REPAIR PARTS

TRACTOR-MODEL NO. MBA16107BRK(96061002200), PRODUCT 960 61 00-22
MOWER

KEY NO.	PART NO.	DESCRIPTION	KEY NO.	PART NO.	DESCRIPTION
1	532 16 91-60	Housing Asm. Mower	44	532 17 55-38	Cover Mandrel Lh
2	872 14 05-06	Bolt Rdhd Sqnk 5/16-18 unc x 3/4	45	532 17 55-39	Cover Mandrel Rh
3	532 16 55-69	Bracket Asm. S-Bar Chass	46	532 13 77-29	Screw Thd Roll 1/4-20 x 5/8
4	532 16 91-67	Bracket Bar Sway Deck	55	532 16 98-49	Arm Idler 107 CRD
5	532 12 46-70	Retainer Spring	61	532 17 51-59	Spring Tension Belt
6	532 16 55-57	Bar Sway	67	532 10 69-32	Knob Rd 3/8-16 Plstc Thds Blk
8	532 18 17-12	Bolt 3/8-24 x 1.25 Gr. 8 Patched	68	532 16 91-78	Hex-Belt Mower
9	810 03 06-00	Washer Lock Hvy 3/8 Unplated	69	532 16 54 92	Shaft Asm W/Lwr Brg Rh Thd CRD
11	532 18 05-83	Blade 3-1 Lh 107	84	532 15 60-85	Keeper Belt Idler
13	532 13 76-45	Shaft Asm. W/Lower Bearing	116	532 18 42-19	Bolt Shoulder
14	532 12 87-74	Housing Mandrel Vented (Machd)	117	532 13 39-57	Wheel Gage Donut Wide
15	532 11 04-85	Bearing Ball Mandrel	118	873 93 06-00	Nut Centerlock 3/8-16 unc
16	532 18 05-84	Blade 3-1 Rh 107	119	819 12 14-14	Washer 3/8 x 7/8 x 14 Ga.
18	872 11 06-06	Bolt RdHd Sqnk 3/8-16 x 3/4	124	872 11 06-12	Bolt Carr Sh 3/8-16 x 1-1/2 Gr. 5
19	532 13 28-27	Bolt Shoulder 5/16-18 Thd Form	130	872 11 05-06	Bolt RdhdSqnk 5/16-18 unc x 3/4
20	532 18 17-13	Bolt 3/8-24 x 1.25 Gr. 8 Ptch Lhthd	131	532 16 56-61	Chute Bagger CRD
21	873 05 05-00	Nut Crown Lock 5/16-16	152	532 17 60-74	Cable Clutch CRD Service
22	532 16 91-65	Bracket Idler RR	158	817 72 04-08	Screw Hex Thd Cut 1/4-20 x 1/2
23	532 16 91-66	Bracket Idler RF	161	532 18 04-24	Blade Cross LH 107
24	532 16 91-70	Bracket Suspension LF	162	532 18 08-78	Adapter Weldment Blade
25	532 16 91-71	Bracket Suspension RF	163	532 18 04-25	Blade Cross RH 107
26	532 16 52-37	Brace Support Susp Frt CRD	164	532 12 49-37	Bearing
27	532 16 91-72	Bracket Asm. Susp RR	185	532 18 82-34	Head Asm. Cable Clutch
28	532 16 91-68	Bracket Asm. Susp LR	--	532 18 18-57	Mandrel Assembly (Includes Housing, Shaft and Shaft Hardware Only - Pulley Not Included)
30	532 17 39-84	Screw Thd Rolling Dod Pt	--	532 18 18-58	Mandrel Asm CRD Lh Threads SVC
31	532 18 76-90	Washer Spacer	--	532 18 17-70	Replacement Mower Complete (Std. Deck - Order separately gauge wheel components key nos. 116-119)
32	532 17 57-07	Mandrel Pulleys			
33	532 17 83-42	Nut Flg Top Lock			
34	532 17 95-09	Bracket Gauge Wheel Lf			
35	532 17 62-92	Bracket Gauge Wheel Rf			
36	532 14 67-63	Pulley Idler V-Groove Dim 4.25			
38	532 16 98-51	Spacer Hub Arm Idler 107 CRD			
39	872 11 06-22	Bolt Crownlock 3/8-16 unc			
40	873 68 06-00	Nut Crownlock 3/8-16 unc			
41	873 90 06-00	Nut Lock 3/8-16			

NOTE: All component dimensions given in U.S. inches
1 inch = 25.4 mm

REPAIR PARTS

TRACTOR-MODEL NO. MBA16107BRK(96061002200), PRODUCT 960 61 00-22
BAGGER

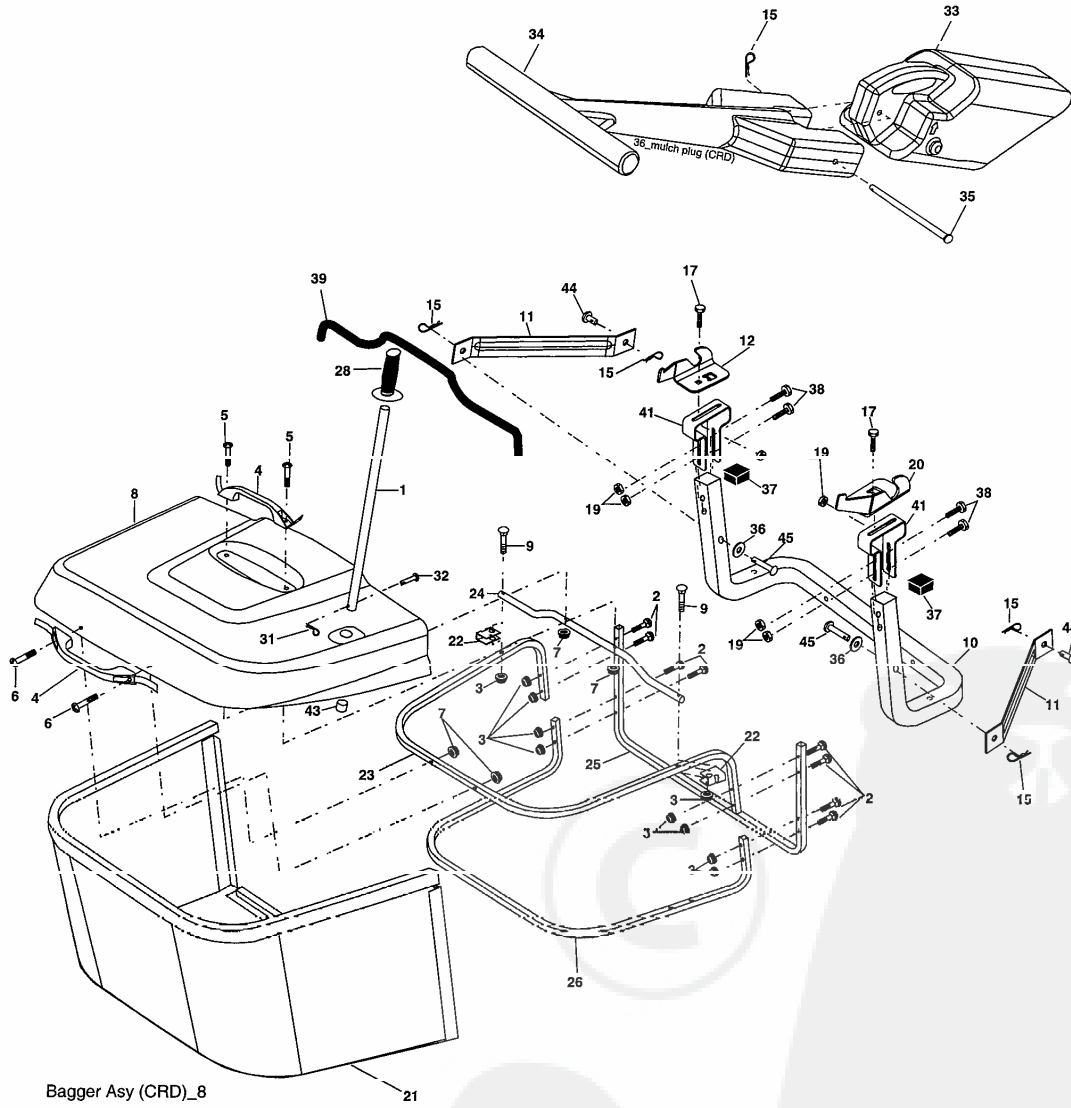

REPAIR PARTS

TRACTOR-MODEL NO. MBA16107BRK(96061002200), PRODUCT 960 61 00-22
BAGGER

KEY NO.	PART NO.	DESCRIPTION
1	532 16 52-49	Tube Handle Bagger CRD
2	872 14 04-16	Bolt Carriage 1/4-20 x 2.0 Gr. 5
3	532 12 39-76	Nut Lock 1/4 Lge Flg Gr. 5 Zinc
4	532 16 99-16	Handle Bagger w/Lvrs Blk CRD
5	874 98 10-24	Screw Pan Head #10-24 x 1.50 Blk
6	874 98 10-32	Screw Pan Hd
7	873 40 10-00	Nut Wiz Lock Hex Serr/Hd 10-24
8	532 18 55-53	Cover Bagger
9	872 14 04-18	Bolt Carriage 1/4-20 x 2.25d x Gr. 5
10	532 18 12-82	Tube Support Bagger CRD
11	532 16 57-19	Bracket Support Upper Bag CRD
12	532 18 88-48	Bracket Pivot LH
15	532 12 46-70	Retainer Spring
17	872 14 05-06	Bolt Rdhd Sht Sqnk 5/16 -18 unc x 3/4
18	819 11 12-16	Washer 11/32 x 3/4 x 16 Ga.
19	873 90 05-00	Nut Lock Hex Flange 5/16-18
20	532 18 88-47	Bracket Pivot RH
21	532 18 08-80	Bag Asm CRD
22	532 16 57-81	Bracket Side Bagger CRD
23	532 16 57-82	Tube Upper Bagger CRD
24	532 16 57-83	Tube Pivot Bagger CRD
25	532 18 01-24	Tube Front Bagger CRD
26	532 16 57-85	Tube Lower Bagger CRD
28	532 16 57-87	Grip Handle Black
31	532 16 98-48	Retainer Clip
32	532 12 68-75	Rivet Rd Hd Drilled 3/8 Dia
33	532 16 93-80	Plug Mulch
34	532 16 55-70	Handle Mulcher
35	532 16 55-72	Pin Mulcher
36	819 13 20-12	Washer 13/32 x 1-1/4 x 12 Ga.
37	532 17 54-01	Plug Support Bagger CRD
38	872 01 05-20	Bolt 5/16-18 x 2-1/2
39	532 18 09-85	Seal 37"
41	532 16 96-83	Bracket Vert Adj Bagger CRD
43	532 17 40-83	Plug Tubing End
44	532 19 33-12	Plug Clevis 3/8 x 1 1/16
45	532 19 33-13	Pin Clevis 3/8 x 2.00

NOTE: All component dimensions given in U.S. inches
1 inch = 25.4 mm

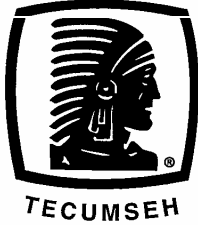

SERVICE POLICY WARRANTY



Issued January 1980
Revised January 1991

LIMITED WARRANTIES FOR NEW PEERLESS GEAR POWER TRAIN COMPONENTS

A. Products Warranted

Peerless Gear and Machine Division of Tecumseh Products Company ("Tecumseh"), subject to the limitations contained below, will, at its option, repair or replace, without charge for parts or labor only, any part of a new Power Train Component (which as used herein means and includes the transaxle, gear box, transmission, differential and right angle drives, and any part of the Power Train Component), EXCEPT any new Power Train Component incorporated in equipment used for commercial or rental purposes, which is found upon examination by any Tecumseh Authorized Service Outlet or by Tecumseh's factory in Grafton, Wisconsin, to be DEFECTIVE IN MATERIAL AND/OR WORKMANSHIP if received by Tecumseh or a Tecumseh Authorized Service Outlet for such examination within TWO YEARS from the date of sale to the original consumer purchaser of Peerless Series 820, 900, 910, 915, 920, 930 transaxles and Series 1100 angle drive and ONE YEAR for all other Peerless products. New Power Train Components incorporated in equipment used for commercial purposes are warranted in the same manner and to the same extent EXCEPT such Power Train Components are warranted for NINETY (90) DAYS ONLY, and must be received by Tecumseh or by a Tecumseh Authorized Service Outlet for such examination within 90 days from the date of sale to the original purchaser. New Power Train Components incorporated in equipment used for rental purposes are warranted in the same manner and to the same extent EXCEPT such Power Train Components are warranted for THIRTY (30) DAYS ONLY, and must be received by Tecumseh or a Tecumseh Authorized Service Outlet within 30 days from the date of sale to the original purchaser.

B. Products And Items Not Warranted

1. Alterations or Modifications of Power Train Components.
2. Accidents, Normal Maintenance, Failure to follow the Original Equipment Manufacturer's Manual.

This warranty covers only parts of new Power Train Components which are found upon examination to be defective in material or workmanship as delivered to the original purchaser. This warranty does not cover defects caused by depreciation or damage caused by normal wear, accidents, improper maintenance, improper use or abuse of the product, failure to follow the instructions contained in an Instruction Manual for the operation of the Power Train Component and parts. The cost of normal maintenance and replacement of service items which are not defective shall be paid for by the original purchaser.

C. Securing Warranty Service

Warranty service can be arranged for by contacting either a Tecumseh Authorized Service Outlet (any Tecumseh Registered Service Dealer, Tecumseh Authorized Service Distributor, or Tecumseh Central Warehouse Distributor) or by contacting Tecumseh, c/o Service Manager, Engine and Transmission Group Service Division, 900 North Street, Grafton, Wisconsin 53024. Warranty service can only be performed by a Tecumseh Authorized Service Outlet or by Tecumseh at its factory in Grafton, Wisconsin. At the time of requesting warranty service, evidence must be presented of the date of sale to the original purchaser. The purchaser shall pay any charges for making service calls and/or for transporting the product to and from the place where the inspection and/or warranty work is performed. The purchaser shall be responsible for any damage or loss incurred in connection with the transportation of Power Train Components and/or part(s) of the Power Train Components submitted for inspection and/or warranty work.

D. Limitation of Damages and Implied Warranties

The foregoing EXPRESSED WARRANTY IS IN LIEU OF ALL OTHER EXPRESS WARRANTIES. Neither Tecumseh nor any of its affiliates makes any warranties, representations or promises, written or oral, as to the quality of the Power Train Component or any of its parts, other than as set forth herein.

ANY IMPLIED WARRANTY OF MERCHANTABILITY OR FITNESS FOR A PARTICULAR PURPOSE, TO THE EXTENT THAT EITHER MAY APPLY TO ANY PART(S) OF POWER TRAIN COMPONENTS, SHALL BE LIMITED IN DURATION TO THE PERIODS OF THE EXPRESSED WARRANTIES DEFINED IN PARAGRAPH A HEREOF. IN NO EVENT WILL TECUMSEH BE LIABLE FOR ANY INCIDENTAL, CONSEQUENTIAL OR SPECIAL DAMAGES AND/OR EXPENSES. Some states do not allow limitations on how long an implied warranty lasts or the exclusion or limitation of incidental or consequential damages, so the above limitation(s) or exclusion(s) may not apply to you. This warranty gives you specific legal rights and you may also have other legal rights which vary from state to state.

E. No Dealer Warranty

Tecumseh neither assumes nor authorizes any other person, natural or corporate, to assume for Tecumseh any other obligations or liabilities in connection with or with respect to any part(s) of a Power Train Component. The seller or dealer of part(s) of a Power Train Component has no authority, whatsoever, to make any representations or promises on behalf of Tecumseh or to modify the terms or limitations of Tecumseh's warranty in any way.

SERVICE NOTES

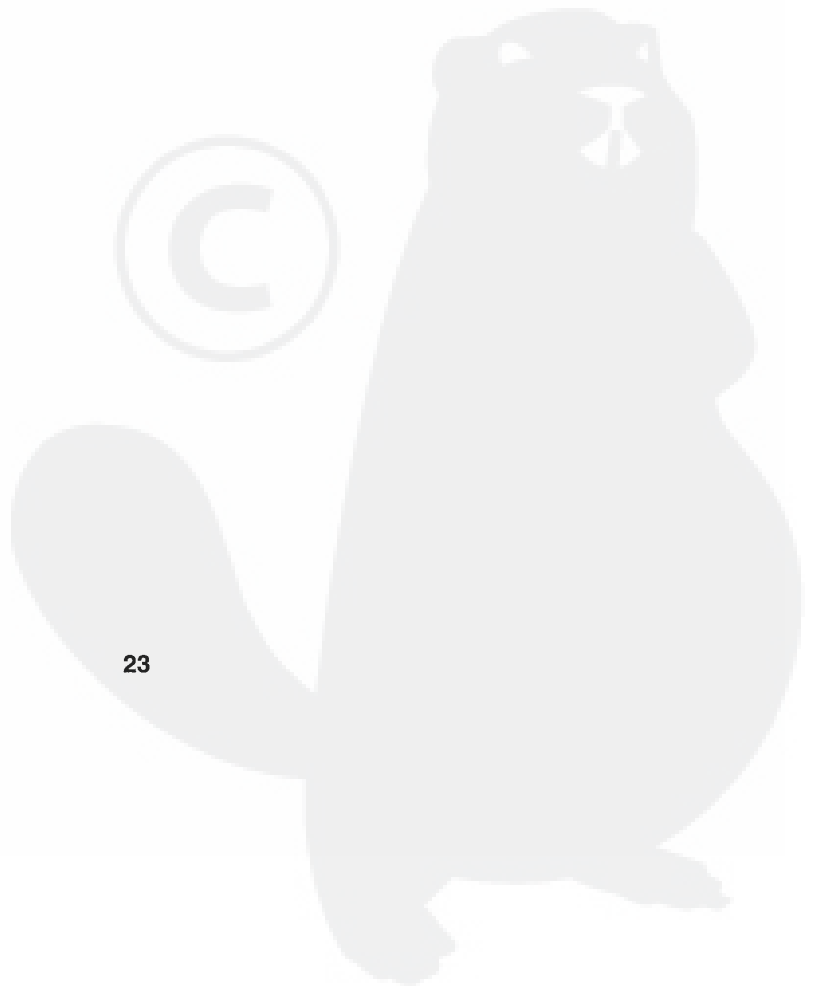
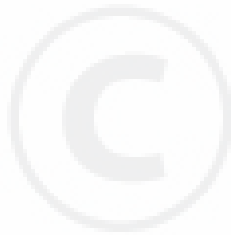

Mr. Bricolage

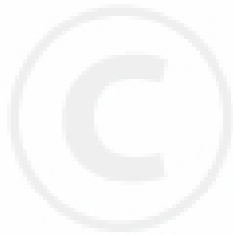

Mr. Bricolage

