

REPAIR PARTS MANUAL
MODEL NO. MC17107 (96011008400)
Lawn Tractor

McCULLOCH^{PM}

532 19 66-82 Rev. 1 01.11.05 TR
Printed in U.S.A.

HOW TO USE THIS MANUAL

This manual is designed to provide the customer with a means to identify the parts on his/her tractor when ordering repair parts. The illustrations may or may not represent the actual assemblies; therefore, it is not recommended to use this manual as a guide to assemble or disassemble the tractor. Some hardware and parts are drawn larger in order to more readily identify them.

Each tractor has its own model number.

The model number for your tractor can be found on the fender under the seat.

When ordering parts, always give the following information:

- Product - "Tractor"
- Model Number - MC17107 (96011008400)
- Part Number
- Part Description

TABLE OF CONTENTS

SCHEMATIC	3
ELECTRICAL	4-5
CHASSIS	6-7
DRIVE	8-9
STEERING	10-11
ENGINE	12-13
SEAT	14
DECALS	15
MOWER LIFT	16-17
MOWER DECK	18-19

**TRACTOR -- MODEL NO. MC17107 (96011008400), PRODUCT NO. 960 11 00-84
SCHEMATIC**

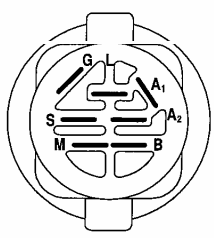
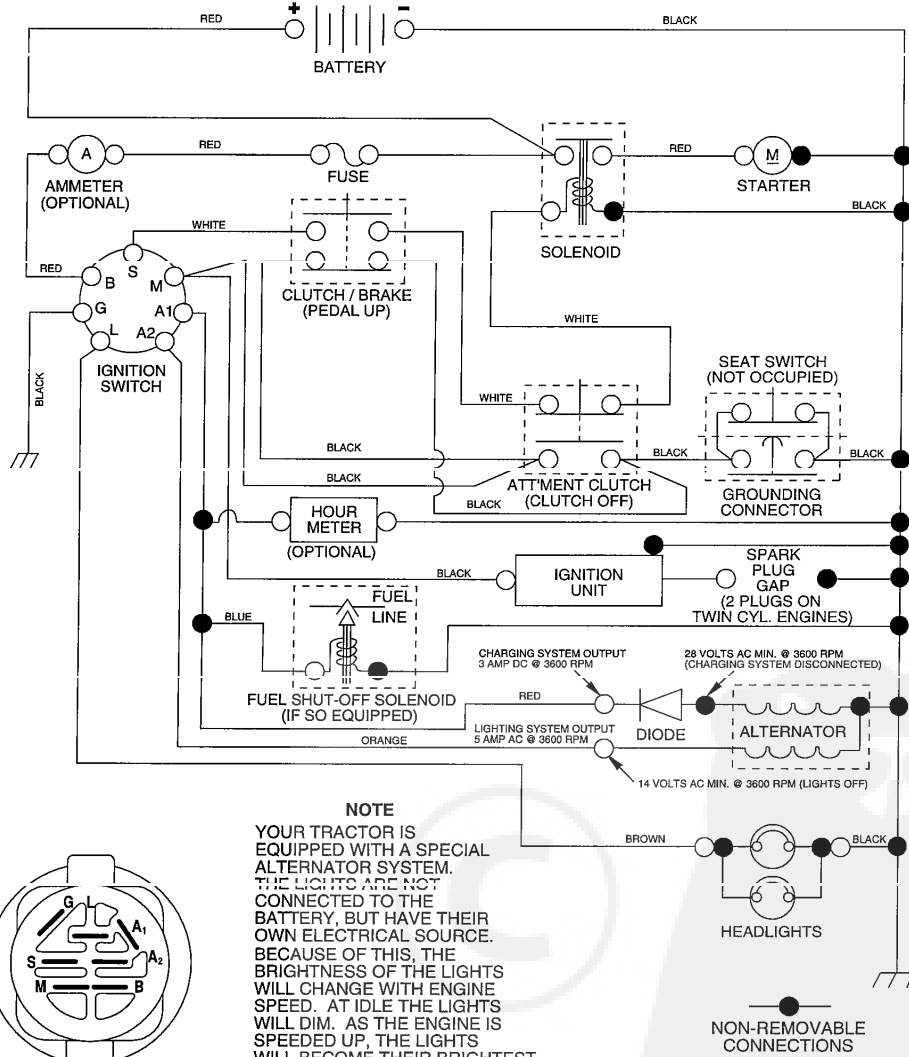

IGNITION SWITCH

POSITION	CIRCUIT	"MAKE"
OFF	M+G+A1	NONE
RUN/LIGHT	B+A1	A2+L
RUN	B+A1	NONE
START	B + S + A1	NONE

NOTE
YOUR TRACTOR IS EQUIPPED WITH A SPECIAL ALTERNATOR SYSTEM. THE LIGHTS ARE NOT CONNECTED TO THE BATTERY, BUT HAVE THEIR OWN ELECTRICAL SOURCE. BECAUSE OF THIS, THE BRIGHTNESS OF THE LIGHTS WILL CHANGE WITH ENGINE SPEED. AT IDLE THE LIGHTS WILL DIM. AS THE ENGINE IS SPEEDED UP, THE LIGHTS WILL BECOME THEIR BRIGHTEST.

WIRING INSULATED CLIPS
NOTE: IF WIRING INSULATED CLIPS WERE REMOVED FOR SERVICING OF UNIT, THEY SHOULD BE REPLACED TO PROPERLY SECURE YOUR WIRING.

02363

REPAIR PARTS

TRACTOR - - MODEL NO. MC17107 (96011008400), PRODUCT NO. 960 11 00-84
ELECTRICAL

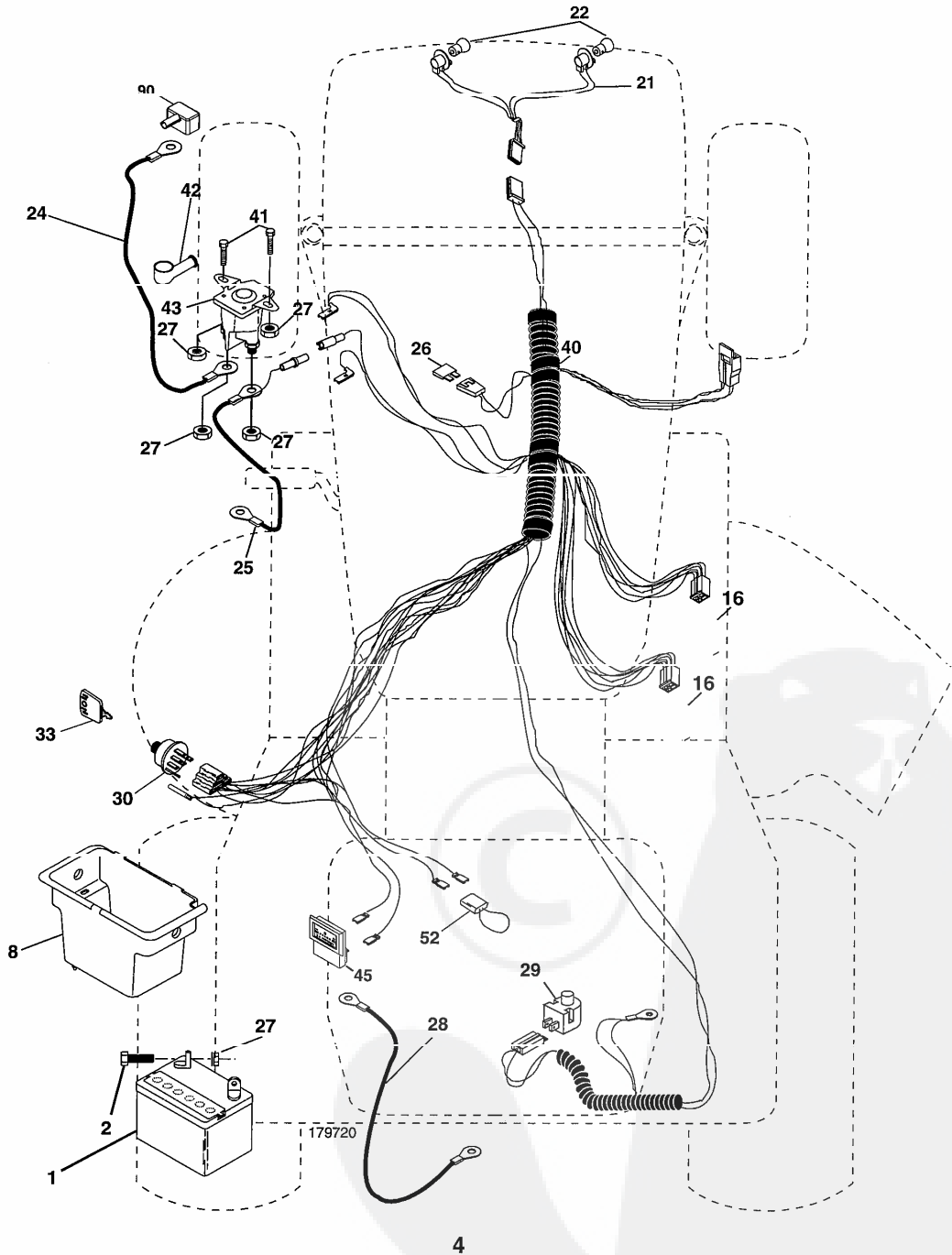

REPAIR PARTS

TRACTOR - - MODEL NO. MC17107 (96011008400), PRODUCT NO. 960 11 00-84
ELECTRICAL

KEY NO.	PART NO.	DESCRIPTION
1	532 16 34-65	Battery 12 Volt 25 Amp
2	874 76 04-12	Bolt Hex Hd 1/4-20 unc x 3/4
8	532 17 66-89	Case Battery Mech Hinge
16	532 17 61-38	Switch Interlock Push-In
21	532 19 37 59	Harness Acn Light W/4152j
22	532 00 41-52	Bulb Light #1156
24	532 12 47-80	Cable Battery 6 Ga. 11"red
25	532 14 61-47	Cable Battery
26	532 17 51-58	Fuse
27	873 51 04-00	Nut Keps Hex 1/4-20 unc
28	532 12 47-73	Cable Ground 6 Ga. 12"black
29	532 12 13-05	Switch Plunger Nc Gray
30	532 17 55-66	Switch Ign
33	532 14 04-01	Key Ign
40	532 17 97-20	Harness ign
41	871 11 04-08	Bolt Blk Fin Hex 1/4-20
42	532 13 15-63	Cover Terminal Red
43	532 17 88-61	Solenoid
45	532 12 14-33	Ammeter
52	532 14 19-40	Protection Wire Loop
90	532 18 04-49	Cover Terminal Battery

NOTE: All component dimensions given in U. S.
inches 1 inch = 25.4 mm.

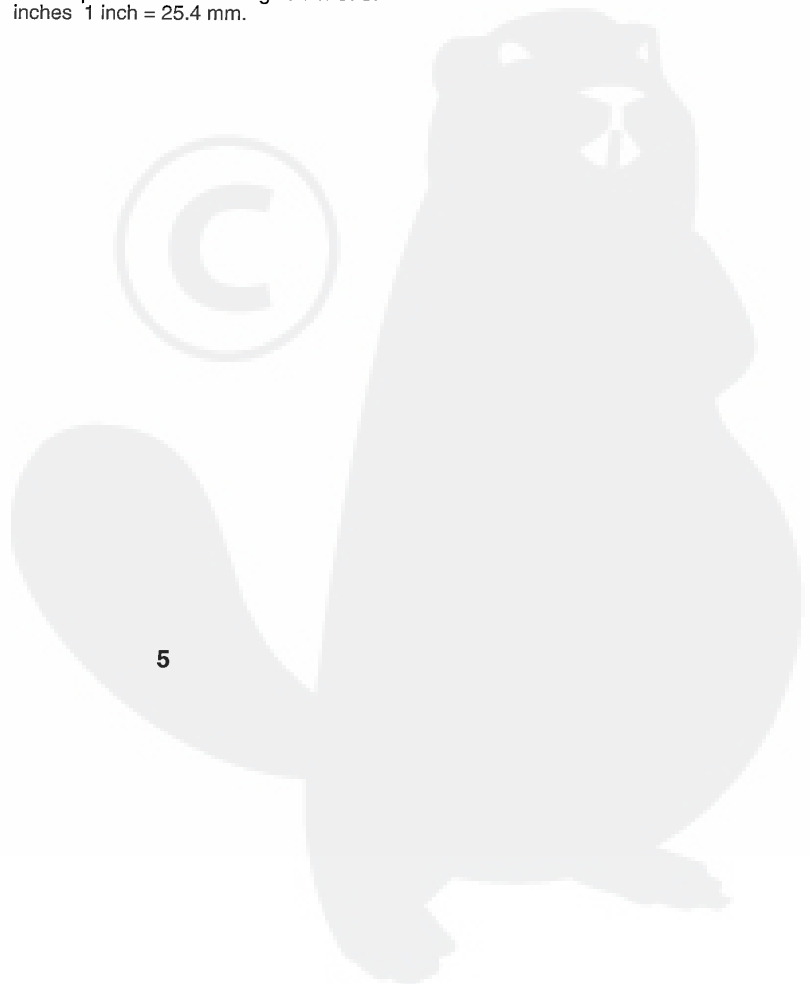

REPAIR PARTS

TRACTOR -- MODEL NO. MC17107 (96011008400), PRODUCT NO. 960 11 00-84
CHASSIS

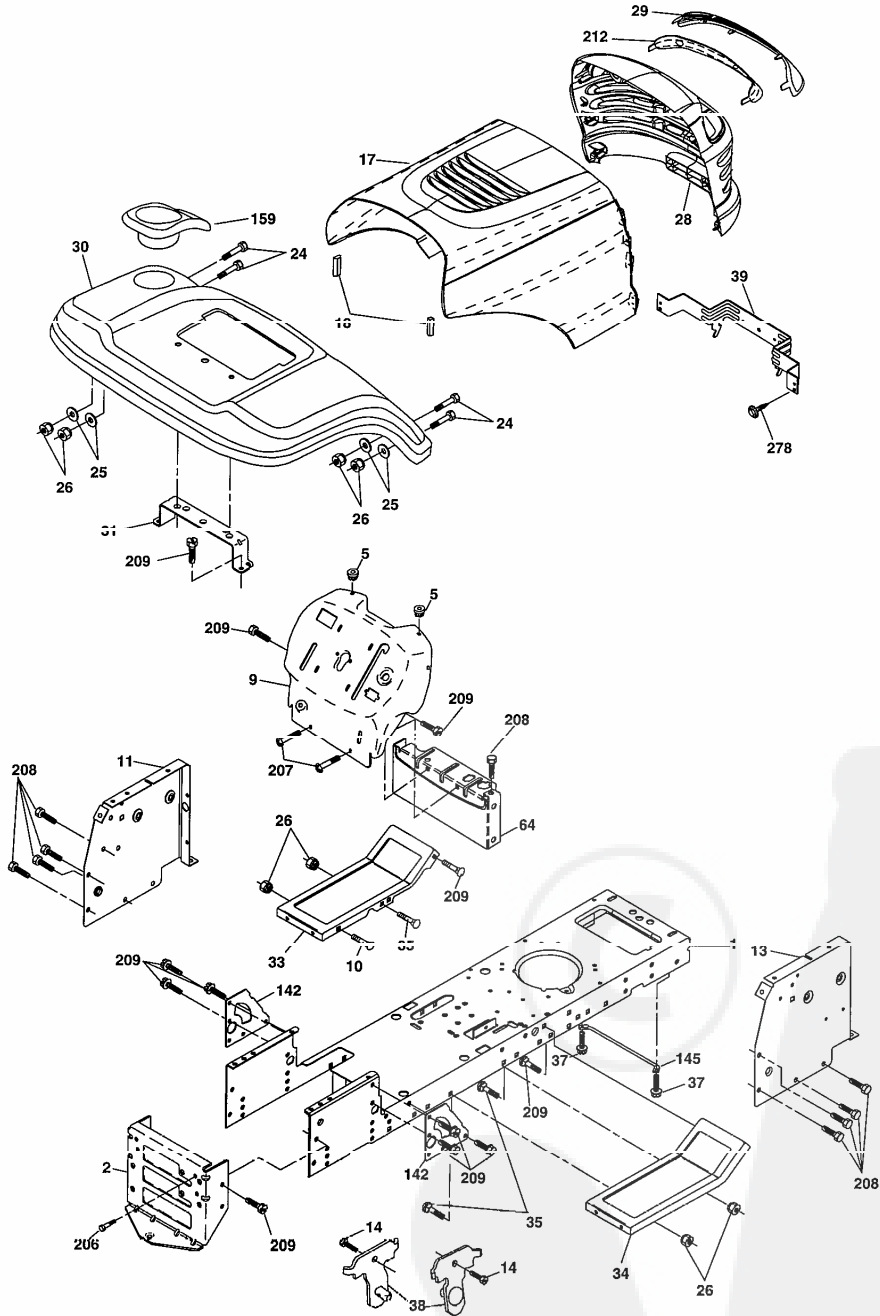

chassis_elite value_stlt_3

REPAIR PARTS

TRACTOR - - MODEL NO. MC17107 (96011008400), PRODUCT NO. 960 11 00-84
CHASSIS

KEY NO.	PART NO.	DESCRIPTION
1	532 17 46-19	Chassis
2	532 17 65-54	Drawbar
5	532 15 52-72	Bumper Hood Dash
9	532 19 11-16	Dash
10	872 14 06-08	Bolt Rdhd Sqnk 3/8-16 unc x 1
11	532 17 49-96	Panel Dash LH
13	532 18 69-52	Panel Dash RH
14	817 49 06-08	Screw Thdrol 3/8-16 x 1/2
17	532 18 65-80	Hood
18	532 18 49-21	Bumper Hood
24	874 78 06-16	Bolt Fin Hex 3/8-16 unc x 1 Gr. 5
25	819 13 13-12	Washer 13/32 x 13/16 x 12 Ga.
26	873 80 06-00	Nut Lock Hex w/Ins 3/8-16 unc
28	532 18 35-52	Grille/Lens Asm (Includes Key Nos. 29 and 212)
29	532 18 58-46	Lens Grille
30	532 13 45-65	Fender
31	532 13 66-19	Bracket Fender Repl 109873X
33	532 18 25-07	Footrest Pnt LH
34	532 18 25-08	Footrest Pnt RH
35	872 11 06-06	Bolt Rdhd Sht Sqnk 3/8-16 x 3/4
37	817 49 05-08	Screw Thdrol 5/16-18 x 1/2 Tyt
38	532 17 57-10	Bracket Asm Pivot Mower Rear
39	532 17 47-14	Bracket, Pivot
64	532 15 47-98	Dash Lower STLT
142	532 17 57-02	Plate Reinforcement STLT
145	532 15 65-24	Rod Pivot Chassis/Hood
159	532 18 56-35	Cupholder
206	532 17 01-65	Bolt Shoulder 5/16-18
207	817 67 05-08	Screw Thdrol 5/16-18 x 1/2
208	817 67 06-08	Screw Thdrol 3/8-16 x 1/2
209	817 00 06-12	Screw 3/8-16 x 3/4
212	532 18 35-50	Insert Lens Reflective
278	532 19 16-11	Screw 10 x 3/4 Single Lead-Hex
--	532 00 54-79	Plug
--	532 19 39-35	Plug Switch Light

NOTE: All component dimensions given in U.S. inches
1 inch = 25.4 mm.

REPAIR PARTS

TRACTOR -- MODEL NO. MC17107 (96011008400), PRODUCT NO. 960 11 00-84
DRIVE

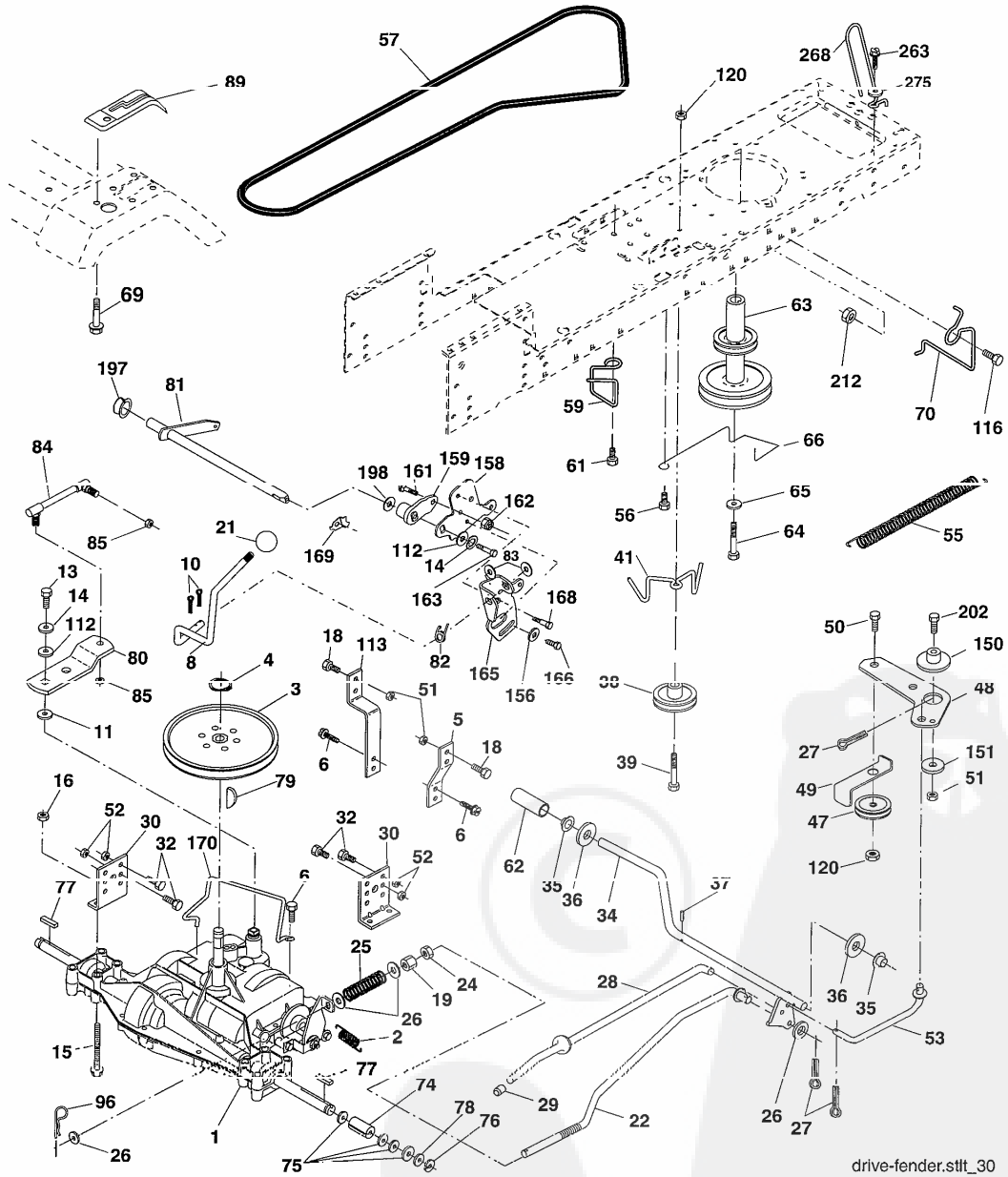

drive-fender.sttt_30

REPAIR PARTS

TRACTOR - - MODEL NO. MC17107 (96011008400), PRODUCT NO. 960 11 00-84 DRIVE

KEY NO.	PART NO.	DESCRIPTION	KEY NO.	PART NO.	DESCRIPTION
1	-----	Transaxle, Poorloss 206 515C (Order parts from transaxle manufacturer)	63	532 18 02-19	Engine Pulley
2	532 14 66-82	Spring Return Brake T/a Zinc	64	532 17 39-37	Bolt Hex 7/16-20 x 4 x Gr. 5
3	532 12 36-66	Pulley Transaxle 18" tires	65	810 04 07-00	Washer Lock Hvy Hlcl Spr 7/16
4	812 00 00-28	Ring Retainer # 5100-62	66	532 15 47-78	Keeper Belt Engine Foolproof
5	532 12 15-20	Strap Torque 30 Degrees	69	532 14 24-32	Screw Hex Wsh Hi-Lo 1/4-1/2 unc
6	817 06 05-12	Screw 5/16-18 x 3/4	70	532 18 02-18	Guide Belt Mower Drive RH
8	532 19 27-06	Rod Shifter Fender Adj Lt	74	532 13 70-57	Spacer Axle
10	876 02 04-16	Pin Cotter 1/8 x 1 Cad	75	532 12 17-49	Washer 25/32 x 1 1/4 x 16 Ga.
11	532 10 57-01	Washer Plate Sni 388 Sq Hoie	76	812 00 00-01	E-ring #5133-75
13	874 55 04-12	Bolt 1/4-28 unf Gr. 8 W/Patch	77	532 12 35-83	Key Square 2 0 x 1845/ 1865
14	810 04 04-00	Washer Lock Hvy Helical 1/4	78	532 12 17-48	Washer 25/32 x 1-5/8 x 16 Ga.
15	874 49 05-44	Bolt Hex Flg Hd. 5/16-18 Gr. 5	79	532 12 50-96	Key Woodruff
16	873 80 05-00	Nut Lock	80	532 13 14-86	Arm Shift
18	874 78 06-16	Bolt, Fin Hex 3/8-16 unc x 1 Gr. 5	81	532 16 55-94	Shaft Asm Cross Tapered 20"t
19	873 80 06-00	Nut Lock 3/8-16 unc	82	532 16 57-11	Spring Torsion T/a
21	532 10 69-33	Knob	83	819 17 12-16	Washer 17/32 x 3/4 x 16 Ga.
22	532 13 08-04	Rod Brake Blk Zinc 26 840	84	532 16 62-28	Link Transaxle
24	873 35 06-00	Nut Hex Jam 3/8-16 unc	85	532 15 03-60	Nut Lock Center 1/4 - 28 FNTHD
25	532 10 68-88	Spring Rod Brake 2 00 Zinc	89	532 19 49-71	Console Shift STLT
26	819 13 13-16	Washer 13/32 x 13/16 x 16 Ga.	96	532 18 30-42	Retainer Spring
27	876 02 04-12	Pin Cotter 1/8 x 3/4 Cad	112	819 09 12-10	Washer 9/32 x 3/4 x 10 Ga.
28	532 17 57-65	Rod Brake Parking	113	532 12 72-85	Strap Torque Lh
29	532 07 16-73	Cap Brake Parking	116	872 14 06-08	Bolt Rdhd Sq Neck 3/8-16 x 1.00
30	532 17 49-73	Bracket Mtg Transaxle	120	873 90 06-00	Nut Lock Flg 3/8-16
32	874 76 05-12	Bolt Hex Hd 5/16-18 unc x 3/4	150	532 17 54-56	Spacer Retainer
34	532 17 55-78	Shaft Asm Pedal Foot	151	819 13 32-10	Washer 13/32 x 2 x 10
35	532 12 01-83	Bearing Nylon Blk 629 Id	156	532 16 60-02	Washer Srrtd 5/16 ID x 1.125
36	819 21 16-16	Washer 21/32 x 1 x 16 Ga	158	532 16 55-89	Bracket Shift Mount
37	532 12 49-63	Pin Roll 3/16 x 1"	159	532 18 39-00	Hub Shift
38	532 17 91-14	Pulley Idler Composite	161	872 14 04-06	Bolt Rdhd Sqnik 1/4-20 x 3/4 Gr. 5
39	872 11 06-22	Bolt Rdhd 3/8-16 x 2-3/4 Gr. 5	162	873 68 04-00	Nut Crownlock 1/4-20 unc
41	532 17 55-56	Keeper Belt Retainer Idler	163	874 78 04-16	Bolt Hex Fin 1/4-20 unc x 1 Gr. 5
47	532 12 77-83	Pulley Idler V Groove Plastic	165	532 16 56-23	Bracket Pivot Lever
48	532 15 44-07	Bellcrank Asm	166	817 49 05-10	Screw 5/16-18 x 5/8
49	532 12 32-05	Retainer Belt Style Spring	168	532 16 54-92	Bolt Shoulder 5/16-18 x .561
50	872 11 06-12	Bolt Hex 3/8-16 x 1-1/2 Gr. 5	169	532 16 55-80	Plate Fastening Lt
51	873 68 06-00	Nut Crownlock 3/8-16 unc	170	532 18 74-14	Keeper Belt T/A
52	873 68 05 00	Nut Crownlock 5/16-18 unc	197	532 16 96-13	Nyliner, Snap - in
53	532 10 57-10	Link Clutch	198	532 16 95-93	Washer, Nyl.
55	532 10 57-09	Spring Return Clutch 6 75	202	872 11 06-14	Bolt, Carriage 3/8 - 16 x 1-3/4
56	817 06 06-20	Screw 3/8-16 x 1-1/4	212	532 14 52-12	Nut Flange Hex Lock
57	532 13 08-01	V-Belt Ground Drive	263	817 00 06-12	Screw 3/8-16 x 3/4
59	532 16 96-91	Keeper Belt Span Ctr	268	532 18 24-02	Guard Muffler RH
61	817 12 06-14	Screw 3/8-16 x .875	275	819 13 16-14	Washer 13/32 x 1 x 14 Ga.
62	532 12 48-72	Cover Pedal Blk Round			

NOTE: All component dimensions given in U.S. inches
1 inch = 25.4 mm

REPAIR PARTS

TRACTOR -- MODEL NO. MC17107 (96011008400), PRODUCT NO. 960 11 00-84
STEERING

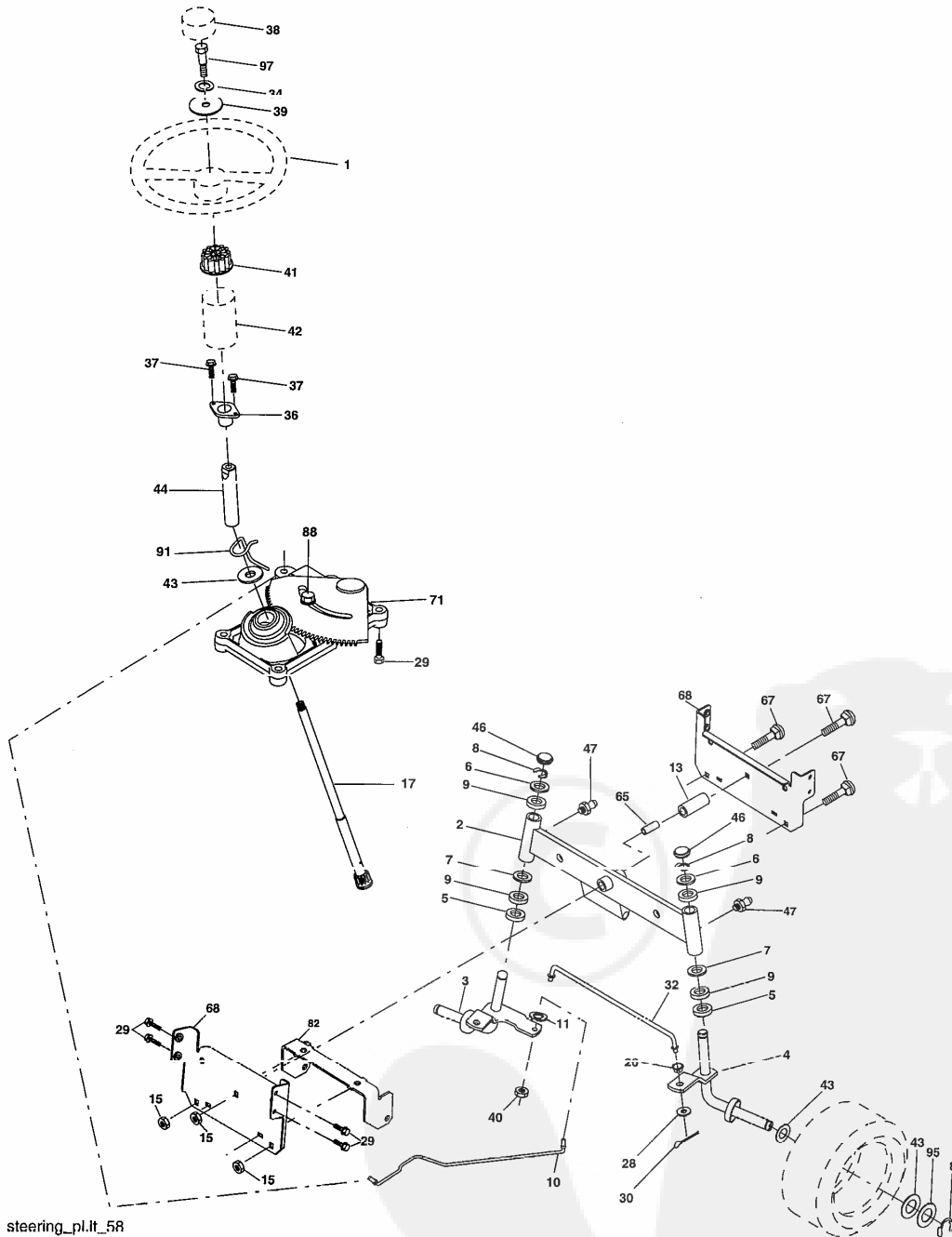

steering_pl.it_58

REPAIR PARTS

TRACTOR - - MODEL NO. MC17107 (96011008400), PRODUCT NO. 960 11 00-84
STEERING

KEY NO.	PART NO.	DESCRIPTION
1	532 18 67-80	Wheel Steering Opp. Blk
2	532 17 51-31	Axle Asm Fr
3	532 16 98-40	Spindle Asm LH
4	532 16 98-39	Spindle Asm RH
5	532 12 49-31	Bearing Race Thrust Harden
6	532 12 17-48	Washer 25/32 x 1-5/8 x 16 Ga.
7	819 27 20-16	Washer 27/32 x 1-1/4 x 16 Ga.
8	812 00 00-29	Ring Clip #15304-75
9	532 12 49-37	Bearing Col Strg Blk
10	532 17 51-21	Link Drag
11	810 04 06-00	Washer Lock Hvy Hlcl Spr 3/8
13	532 13 65-18	Spacer Brace Axle
15	532 14 52-12	Nut Hexflange Lock
17	532 19 07-53	Shaft Asm Strg
26	532 12 68-47	Bushing Link Drag Blk LR
28	819 13 14-16	Washer 13/32 x 7/8 x 16 Ga.
29	817 00 06-12	Screw 3/8-16 x .75
30	976 02 04 12	Pin Cotter 1/8 x 3/4 Cad
32	532 19 27-57	Rod Tie Wire Form
34	810 04 05-00	Washer Lock Hvy Hlcl Spr. 5/16
36	532 15 50-99	Bushing Strg Nat .623/.618ld
37	532 15 29-27	Screw TT #10-32 x 5 x 3/8 Flange
38	532 19 29-16	Cap Wheel Steer
39	819 11 38-12	Washer 11/32 ID x 2-3/8 OD 12 Ga.
40	873 54 06-00	Nut Lock Crown 3/8-24
41	532 18 67-37	Adaptor Wheel Strg
42	532 16 96-33	Boot Shaft Steering
43	532 12 17-48	Washer 25/32 x 1-5/8 x 16 Ga.
44	532 19 07-52	Extension Steering
46	532 12 12-32	Cap Spindle Fr Top Blk
47	532 18 32-26	Fitting Grease
65	532 16 03-67	Spacer Brace Axle
67	872 14 06-18	Bolt RDHD SQ 3/8-16 unc x 2-1/4
68	532 16 98-27	Brace Axle
71	532 17 51-46	Steering Asm.
82	532 16 98-35	Bracket Susp. Chassis Front
88	532 17 51-18	Bolt Shoulder 7/16-20
91	532 17 55-53	Clip Steering
95	532 18 89-67	Washer Harden
97	874 78 05-64	Bolt 5/16-18 unc x 4" L Gr. 5

NOTE: All component dimensions given in U.S. inches
1 inch = 25.4 mm.

REPAIR PARTS

TRACTOR - - MODEL NO. MC17107 (96011008400), PRODUCT NO. 960 11 00-84
ENGINE

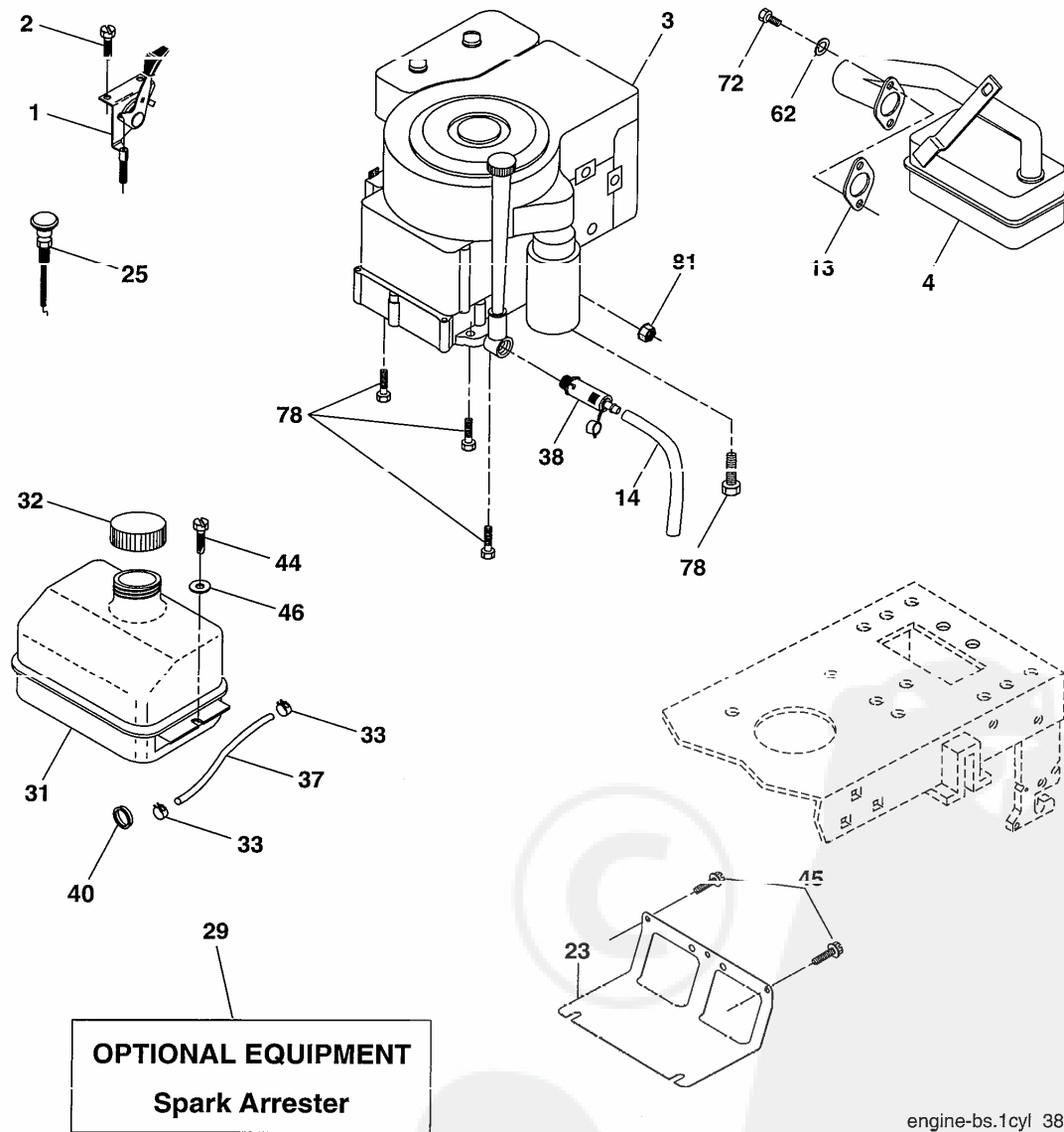

engine-bs.1cyl 38

REPAIR PARTS

TRACTOR - - MODEL NO. MC17107 (96011008400), PRODUCT NO. 960 11 00-84
ENGINE

KEY NO.	PART NO.	DESCRIPTION
1	532 17 05-51	Control Throttle
2	817 72 04-08	Screw Hex Thd Cut 1/4-20 x 1/2
3	-----	Engine Briggs & Stratton 31C707 (Order parts from engine manufacturer)
4	532 13 73-52	Muffler
13	532 16 52-91	Gasket Eng
14	532 14 84-56	Tube Drain Oil Easy
23	532 16 98-37	Shield Brn/Dbr Guard
25	532 19 06-95	Control Choke
29	532 13 71-80	Kit Spark Arrecter
31	532 18 77-50	Tank Fuel Front 1.25
32	532 14 05-27	Cap Asm Fuel W/sym Vented
33	532 12 34-87	Clamp Hose Blk
37	532 13 70-40	Line Fuel 20"
38	532 13 13 54	Plug Drain Oil Easy
40	532 12 40-28	Bushing Snap Nyl Blk Fuel Line
44	817 67 04-12	Screw Hexwsh Thdrol 1/4-20 x 3/4
45	817 00 06-12	Screw Hexwsh Thdrol 3/8-16 x 3/4
46	819 09 14-16	Washer 9/32 x 7/8 x 16 Ga.
62	810 01 05-00	Washer Split
72	871 07 05-12	Screw Hex Hd Cap 5/16-18 x 3/4
78	817 06 06-20	Screw 3/8-16 x 1-1/4
81	873 51 04-00	Nut Keps Hex 1/4-20 unc

NOTE: All component dimensions given in U.S. inches
1 inch = 25.4 mm

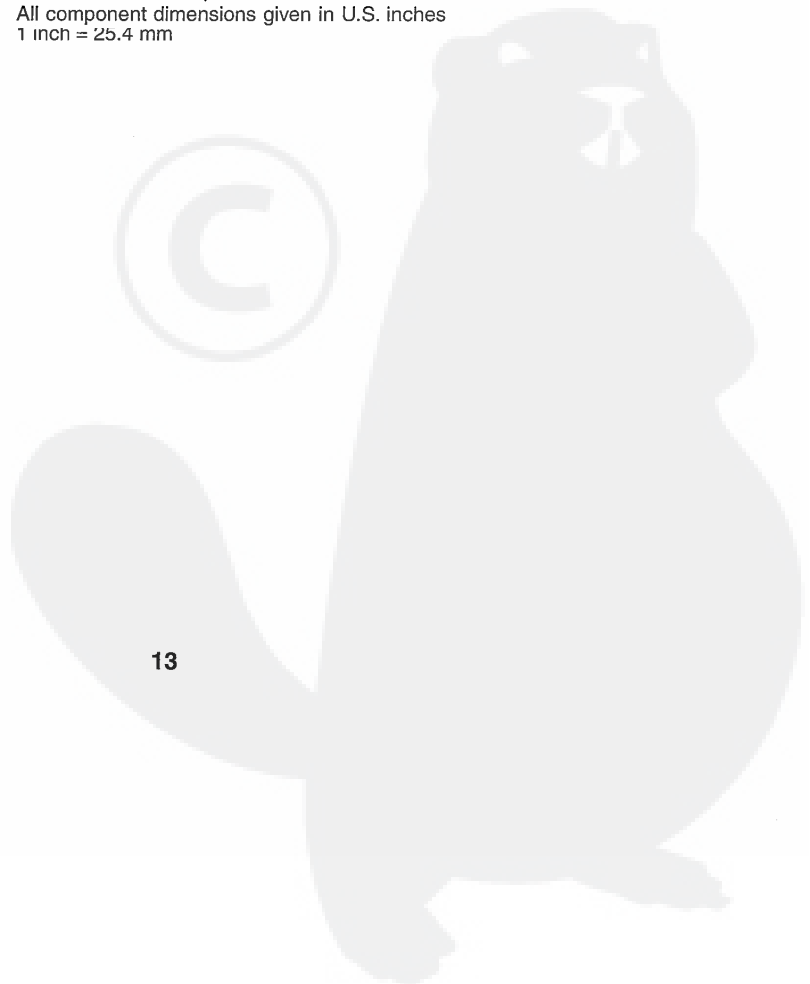
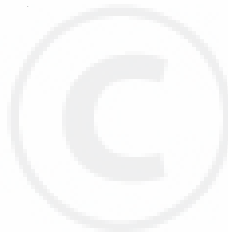

REPAIR PARTS

TRACTOR -- MODEL NO. MC17107 (96011008400), PRODUCT NO. 960 11 00-84
SEAT

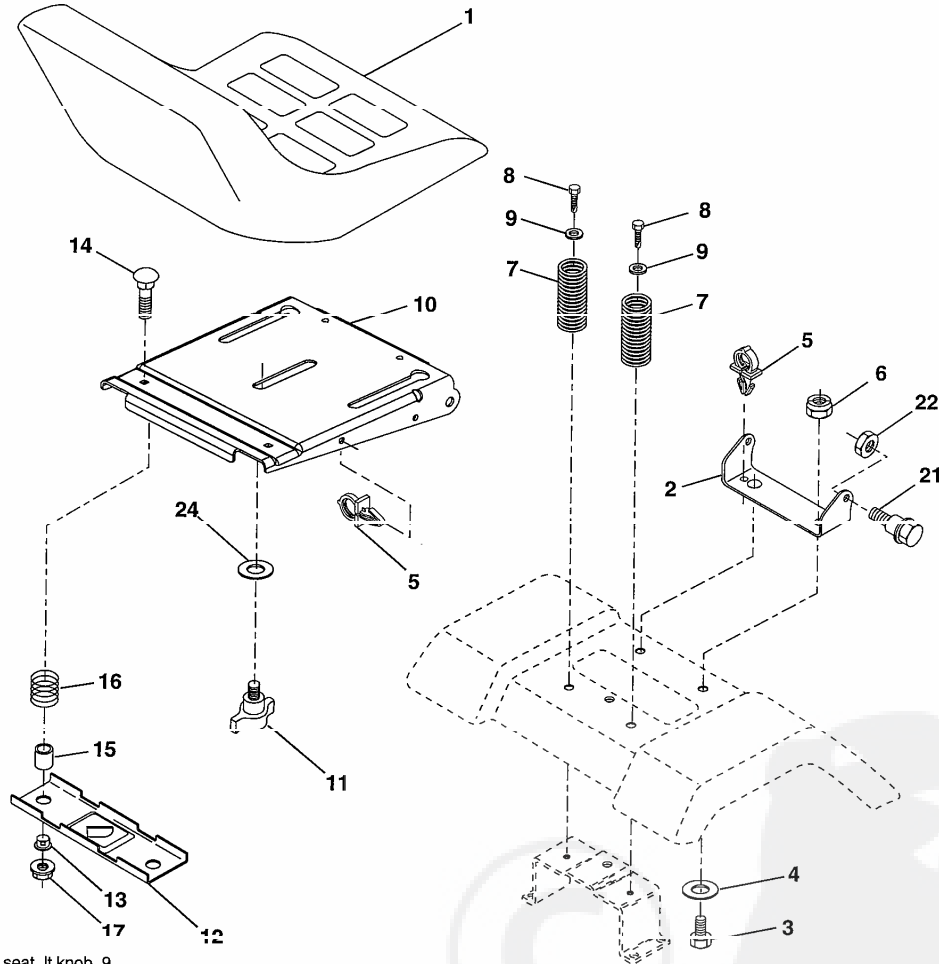

seat_it.knob_9

KEY NO.	PART NO.	DESCRIPTION
1	532 18 87-05	Seat
2	532 18 01-66	Bracket Pivot
3	871 11 06-16	Bolt Fin Hex 3/8-16 unc x 1
4	819 13 16-10	Washer 13/32 x 1 x 10 Ga.
5	532 14 50-06	Clip Push In
6	873 80 06-00	Nut Lock Hex w/Wsh 3/8-16 unc
7	532 12 41 81	Spring Seat Cprsn 2 250 Blk Δ
8	817 00 06-16	Screw 3/8-16 x 1.5
9	819 13 16-14	Washer 13/32 x 1 x 14 Ga.
10	532 18 01-86	Pan Seat
11	532 16 63-69	Knob Seat
12	532 12 12-46	Bracket Mounting Switch

KEY NO.	PART NO.	DESCRIPTION
13	532 12 12-48	Bushing Snap Blk Nyl 50 Id
14	872 05 04-12	Bolt Rdhd Sht Nk 1/4-20 x 1-1/2
15	532 13 43-00	Spacer Split 28 x 96 Yel Zinc
16	532 12 12-50	Spring Cprsn 1 27 Blk Pnt
17	532 12 39-70	Nut Lock 1/4 Lge Flg Gr. 5 Zinc
21	532 17 18-52	Bolt Shoulder 5/16-18 unc -2A
22	873 80 05-00	Nut Lock Hex W/Insert 5/16-18 unc
24	819 17 19-12	Washer 17/32 x 1-3/16 x 12 Ga.

NOTE: All component dimensions given in U.S. inches.
1 inch = 25.4 mm

REPAIR PARTS

TRACTOR -- MODEL NO. MC17107 (96011008400), PRODUCT NO. 960 11 00-84
DECALS

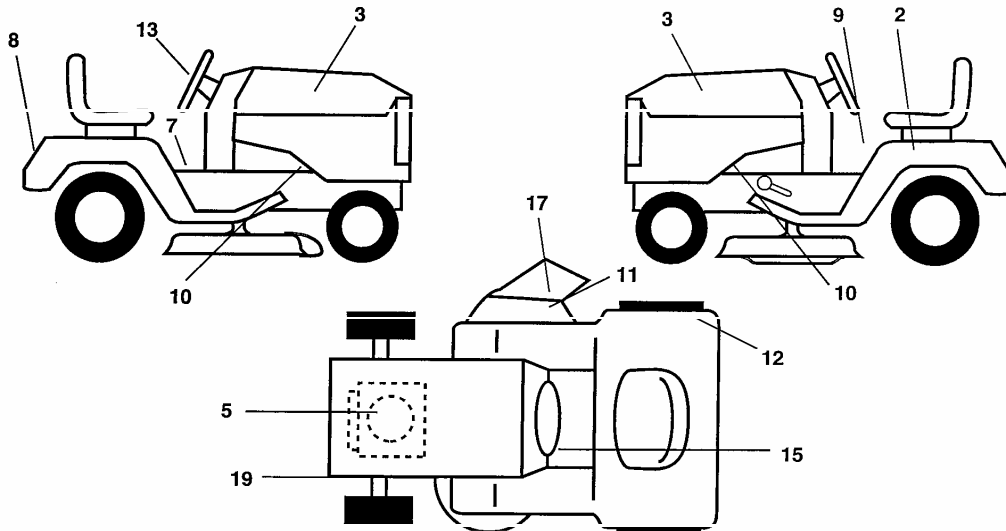

KEY NO.	PART NO.	DESCRIPTION
2	532 14 50-05	Decal Bat Dan/Poi P/L Symbols
3	532 18 96-91	Decal Hood
5	532 19 45-81	Decal Engine
7	532 14 08-37	Decal Saddle Brake Parking
8	532 18 96-93	Decal Fender
9	532 14 54-98	Decal Read Owners Manual Syms
10	532 15 97-36	Decal Chassis Hot Muffler
11	532 18 21-66	Decal Mower Cut finger Symbol
12	532 18 04-32	Decal 100 DbA
13	532 18 96-99	Decal Steering Wheel
15	532 15 97-37	Decal Brake/Clutch

KEY NO.	PART NO.	DESCRIPTION
17	532 17 91-28	Decal Deck "B"
19	532 16 03-96	Decal V-Belt Sch
--	532 16 25-98	Decal Drawbar Load Limit
--	532 13 83-11	Decal Lift Handle (Lift Handle)
--	532 18 10-90	Pad, Footrest RH
--	532 18 10-91	Pad, Footrest LH
--	532 19 44-98	Manual Operator's Euro
--	532 19 44-99	Manual Operator's Scan
--	532 19 45-01	Manual E-Bloc
--	532 19 66-82	Manual Parts

WHEELS & TIRES

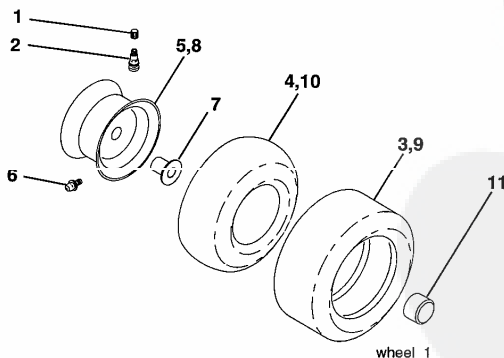

KEY NO.	PART NO.	DESCRIPTION
1	532 05 91-92	Cap Valve Tire
2	532 06 51-39	Stem Valve
3	532 10 62-22	Tire F Ts 15 x 6 0 - 6 Service
4	532 05 99-04	Tube Front (Service Item Only)
5	532 18 33-37	Rim Asm 6" front Service
6	532 12 49-57	Fitting Grease (Front Wheel Only)
7	532 12 49-59	Bearing Flange (Front Wheel Only)
8	532 18 33-38	Rim Asm 8" rear Service
9	532 10 62-68	Tire R Ts 18 x 9.5-8 C. Service
10	532 12 49-26	Tube Rear (Service Item Only)
11	532 17 50-39	Cap Axle Blk 1 50 x 1 00

NOTE: All component dimensions given in U.S. inches
1 inch = 25.4 mm

REPAIR PARTS

TRACTOR -- MODEL NO. MC17107 (96011008400), PRODUCT NO. 960 11 00-84
MOWER LIFT

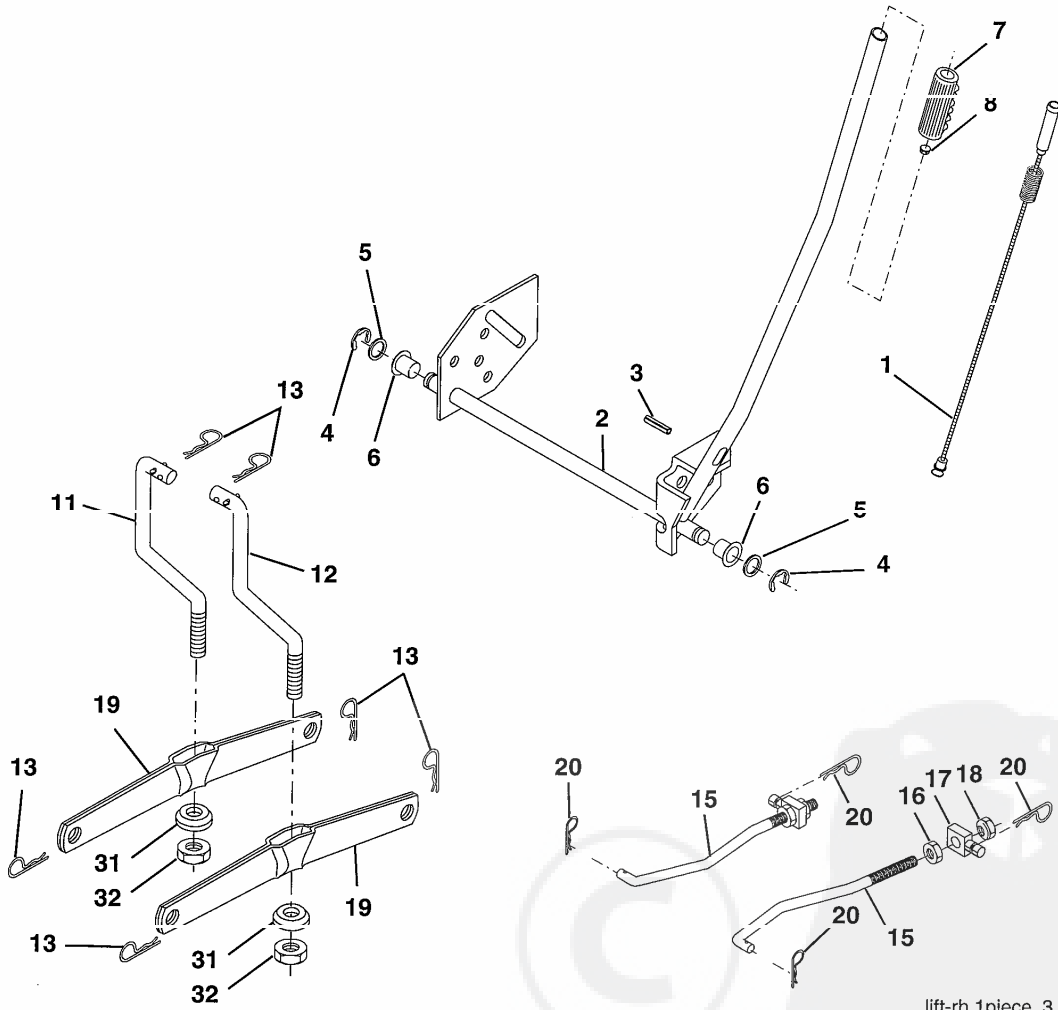

lift-rh.1piece_3

REPAIR PARTS

TRACTOR - - MODEL NO. MC17107 (96011008400), PRODUCT NO. 960 11 00-84
MOWER LIFT

KEY NO.	PART NO.	DESCRIPTION
1	532 15 94-61	Wire Asm Inner W/Plunger
2	532 15 94-76	Shaft Asm Lift
3	532 18 88-22	Pin Groove
4	812 00 00-02	E Ring #5133-62
5	819 21 16-21	Washer PLTD 21/32 x 1 x 21 Ga.
6	532 12 01-83	Bearing Nylon Blk 629 Id
7	532 10 94-13	Grip Handle Bicycle Matte Blk
8	532 12 45-26	Button Plunger Black
11	532 13 98-65	Link Lift LH
12	532 13 98-66	Link Lift RH
13	532 12 46-70	Retainer Spring
15	532 17 32-88	Link Front
16	873 35 08-00	Nut Jam Hex 1/2-13 unc
17	532 17 56-89	Trunnion
18	873 80 08-00	Nut Lock w/wsh 1/2-13 unc
19	532 13 98-68	Arm Suspension Rear
20	532 16 35-52	Retainer Spring
31	532 16 98-65	Bearing Pvt Lift
32	873 54 06-00	Nut Crownlock 3/8-24

NOTE: All component dimensions given in U.S. inches
1 inch = 25.4 mm

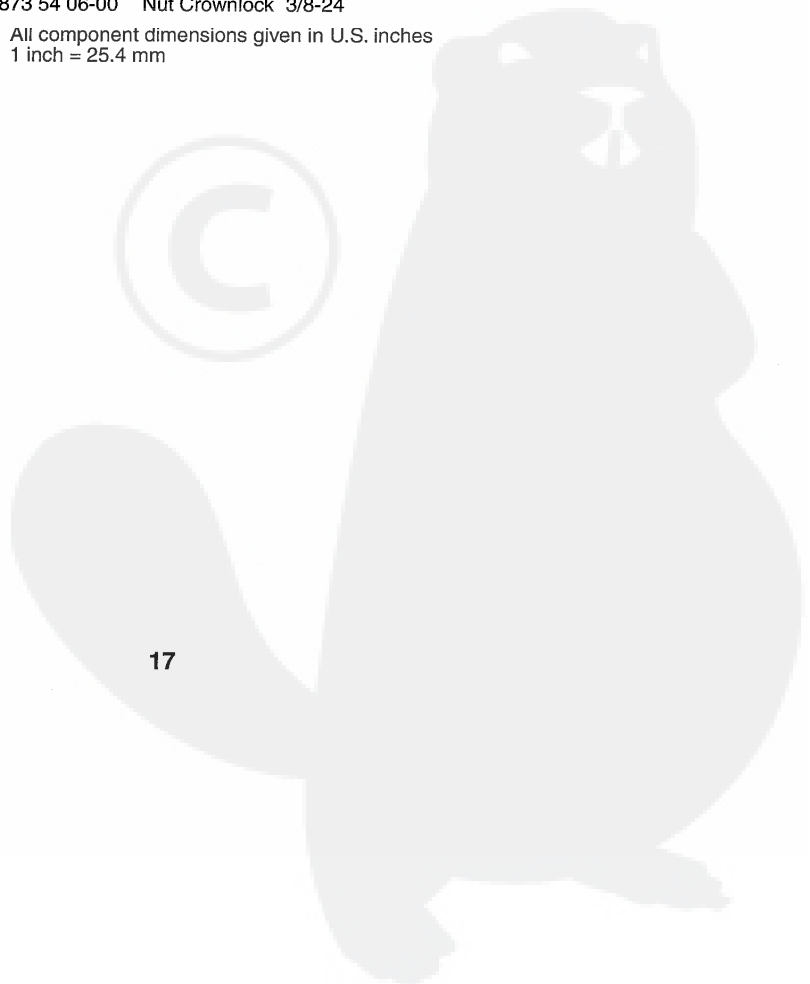
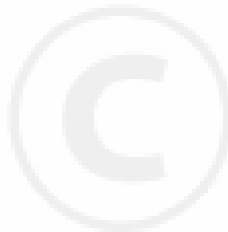

REPAIR PARTS

TRACTOR - - MODEL NO. MC17107 (96011008400), PRODUCT NO. 960 11 00-84
MOWER DECK

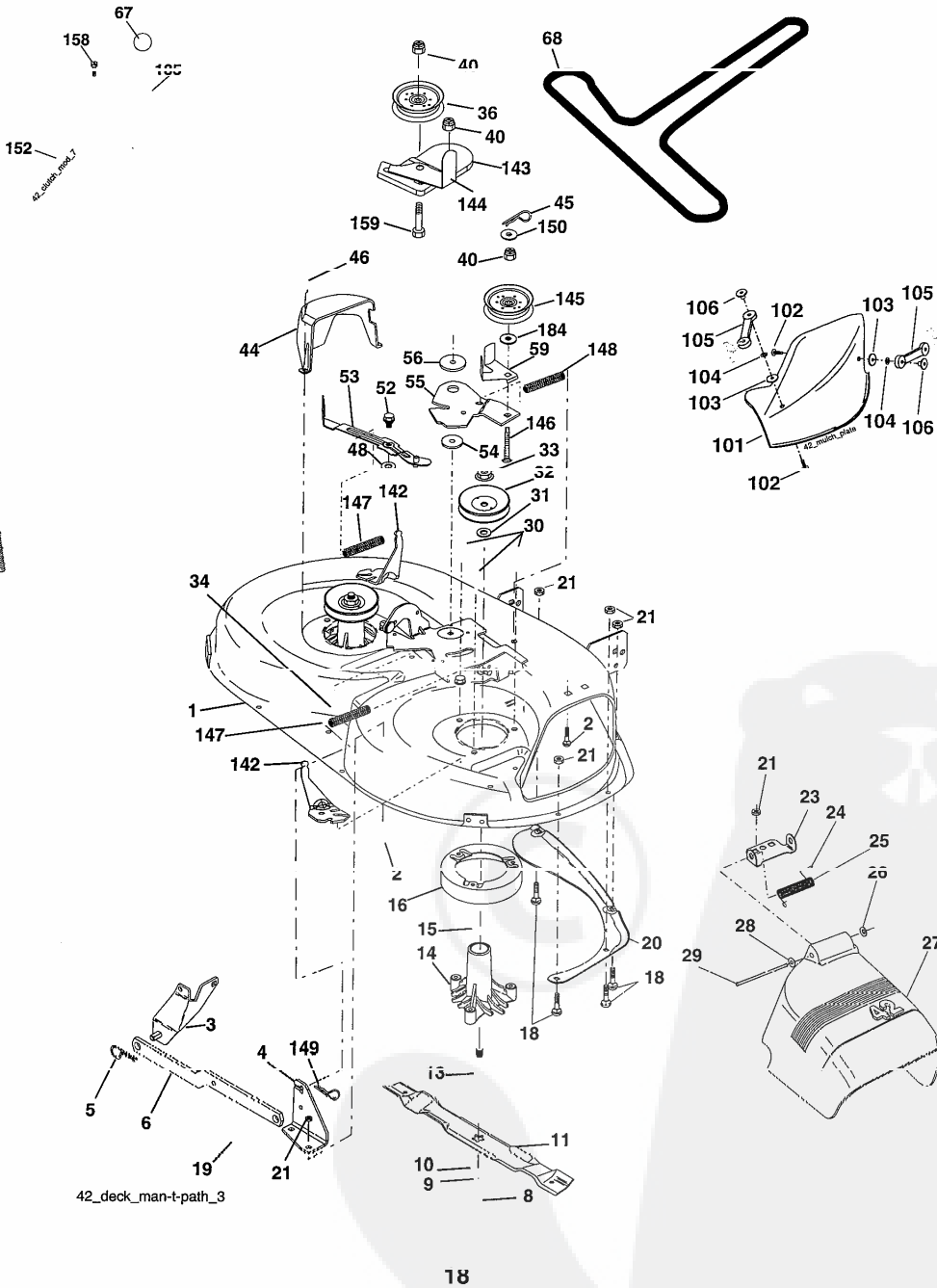

REPAIR PARTS

TRACTOR - - MODEL NO. MC17107 (96011008400), PRODUCT NO. 960 11 00-84
MOWER DECK

KEY NO.	PART NO.	DESCRIPTION	KEY NO.	PART NO.	DESCRIPTION
1	532 16 58-92	Housing Asm Mower 42" T-Path	53	532 18 49-07	Arm Asm Pad Brake
2	872 14 05-06	Bolt Rdhd Sqnk 5/16-18 unc x 3/4	54	532 17 85-15	Washer Hardened
3	532 13 80-17	Bracket Asm Fr Sway Bar 38/42	55	532 15 50-46	Arm Idler 42" mower LT/YT
4	532 16 54-60	Bracket Asm Deck 42" sway Bar	56	532 16 57-23	Spacer Retainer Pm Mower
5	532 12 46-70	Retainer Spring	59	532 14 10-43	Guard TUV Idler
6	532 17 80-24	Bar Sway Deck	67	532 10 69-32	Knob Rd 3/8-16 Plstc Thds Blk
8	532 85 08-57	Bolt 3/8 - 24 x 1.25 Gr. 8	68	532 18 02-15	V-Belt Mower
9	810 03 06-00	Washer Lock Hvy 3/8 Unplated	101	532 13 64-20	Mulcher Cover
10	532 14 02-96	Washer Hard Blade Mower	102	871 08 10-10	Screw 10-24 x 5/8
11	532 13 41-49	Blade Mower Mulch	103	819 06 12-16	Washer # 10
13	532 13 76-45	Shaft Asm W/Lower Bearing	104	810 07 10-00	Washer, Lock #10
14	532 12 87-74	Housing Mandrel Vented (Machd)	105	532 16 07-93	Latch Assembly
15	532 11 04-85	Bearing Ball Mandrel	106	532 12 40-05	Nut, Weld
16	532 17 44-93	Stripper Round Mower	142	532 16 58-90	Arm Spring Brake Mower
18	872 14 05-05	Bolt Carr 5/16-18 x 5/8	143	532 15 71-09	Bracket Arm Idler 42"
19	532 13 28-27	Bolt Shoulder	144	532 15 86-34	Keeper Belt 42" Clutch Cable
20	532 15 97-70	Baffle Vortex 42"	145	532 18 53-33	Pulley Idler Flat
21	873 68 05-00	Nut Crown Lock 5/16-18	146	532 17 19-77	Bolt Carriage Idler
23	532 17 75-63	Bracket Deflector Mower 42"	147	532 17 97-48	Spring Extension
24	532 10 53-04	Cap Sleeve 80x 112 Blk Mower	148	532 16 90-22	Spring Return Idler
25	532 12 37-13	Spring Torsion Deflector 2 52	149	532 16 58-98	Retainer Spring Yellow
26	532 11 04-52	Nut Push Phos & Oil	150	819 09 12-16	Washer 9/32 x 3/4 x 16 Ga.
27	532 17 18-59	Shield Deflector Mower 42"	152	532 18 15-55	Clutch Cable 42"
28	819 11 10-16	Washer 11/32 x 5/8 x 16 Ga.	158	817 72 04-08	Screw Hex Thd Cut 1/4-20 x 1/2
29	532 13 14-91	Rod Hinge 42" 6 75 Wlg	159	872 14 06-14	Bolt Rdhd Sqnk 3/8-16 unc x 1-3/4
30	532 17 39-84	Screw Thdrol	184	819 13 14-10	Washer 13/32 x 7/8 x 10 Ga.
31	532 18 76-90	Washer Spacer Mower Vented	185	532 18 82-34	Head Asm Cable Clutch
32	532 15 35-35	Pulley Mandrel 42/44/50	--	532 13 07-94	Mandrel Asm. (Includes Housing, Shaft and Shaft Hardware Only - Pulley Not Included)
33	532 17 83-42	Nut Top Lock Fling	--	532 18 12-68	Replacement Mower, Complete (Std. Deck - Order separately mulcher cover components key nos. 101-106)
34	872 11 06-12	Bolt Rdhd 3/8-16 unc x 1-3/4 Gr. 5			
36	532 13 14-94	Pulley Idler Flat 3 060			
40	873 90 06-00	Nut, Crownlock 3/8-16 unc			
44	532 14 00-88	Guard Mandrel LH Black			
45	532 12 47-88	Spring Retainer 1" Zinc/cad			
46	532 13 77-29	Screw Hex Thd Cut 1/4-20 x 5/8 T			
48	532 13 39-44	Washer Hardened Smaller			
52	532 13 98-88	Bolt Shoulder 5/16-18 unc Blkz			

NOTE: All component dimensions given in U.S. inches
1 inch = 25.4 mm

Electrolux Outdoor Products Service Contacts

BELGIQUE/BELGIË

Electrolux Outdoor Products
Tel: 02 363 0311, Fax: 02 363 0391

ČESKÁ REPUBLIKA

Electrolux, spol. S.r.o., oz Electrolux Outdoor Products,
Na Krecku 365 Praha 10 - Horní Mecholupy
Tel: 02/7487 0164, Info-linka: 0800/110 220
Internet: www.partner-flymo.cz E-mail: info@husqvarna.cz

DANMARK

Electrolux Outdoor Products, Flymo/Partner A/S,
Lundtoftegaardsvej 93A, DK 2800 Kgs.Lyngby
Tel: 45 87 75 77, Fax: 45 93 33 08 www.flymo-partner.dk

DEUTSCHLAND

Electrolux Outdoor Products
Tel: 097 21 7640, Fax: 097 21 764202

ESTONIA

Electrolux Estonia Ltd (Electrolux Eesti AS)
Tel: (372) 6650010

FRANCE

Electrolux Outdoor Products
Tel 01 46 67 8141, Fax 01 43 34 2491

FINLAND SUOMI

Electrolux Outdoor Products Finland
Tel: 00 39611, Fax: 00 39 612632

ITALIA

McCulloch Italiana s.r.l. - Via Como 72, 23868 Valmadrera
(LECCO) - ITALIA, Tel: 800 017829, Fax: 0341 581671

IRELAND

Electrolux Outdoor Products
Tel: 01 4565222, Fax: 01 4568551

MAGYARORSZÁG

Electrolux Lehel Kft
Tel: 00 36 1 251 41 47

NORGE

Electrolux Outdoor Products
Tel: 69 10 47 90

NEDERLAND

Electrolux Outdoor Products BV
Tel: 0172-468322, Fax: 0172-468219

ÖSTERREICH

HUSQVARNA Zentralwerkstätte, Industriezeile 36, 4020 LINZ,
Tel: 0732 770101-60, Fax: 0732 795922

POLSKA

Electrolux Poland Sp. z o.o. Husqvarna, 01-612 Warszawa
Myslowicka 10/2
Tel: (22) 8332949

SLOVENIJA

HUSQVARNA-Ges m b H Nfg KG, Industriezeile 36, 4020 LINZ,
Tel: 0732 77 01 01-0, Fax: 0732 77 01 01.40
Internet: www.husqvarna.at E-mail: office@husqvarna.co.at

SLOVENSKA

Electrolux Slovakia s.r.o., Borova Sihat 211, 033 01 Lipt. Hradok
Tel: 044 522 14 19, Fax: 044 522 14 18, www.flymo-partner.sk

SCHWEIZ/SUISSE/SUIZZERA

Electrolux Outdoor Products
Tel 062 889 93 50 / 889 94 25, Fax 062 889 93 60 / 889 94 35

SVERIGE

Electrolux Outdoor Products, Sverige
Tel: 036 0 14 67 00, Fax: 036 0 14 60 70

UNITED KINGDOM

Electrolux Outdoor Products, United Kingdom
Tel: 01325 300303, Fax: 01325 310339

McCULLOCH^{PM}

www.electrolux.com/mcculloch

