



**REPAIR PARTS MANUAL**  
**MODEL NO. RELTS1136A**  
**Lawn Tractor**

---

**Rally**

# HOW TO USE THIS MANUAL

This manual is designed to provide the customer with a means to identify the parts on his/her tractor when ordering repair parts. The illustrations may or may not represent the actual assemblies; therefore, it is not recommended to use this manual as a guide to assemble or disassemble the tractor. Some hardware and parts are drawn larger in order to more readily identify them.

Each tractor has its own model number.

The model number for your tractor can be found on the fender under the seat.

When ordering parts, always give the following information:

- Product - "Lawn Tractor"
- Model Number - "RELTS1136A"
- Part Number
- Part Description

## TABLE OF CONTENTS

|                                    |              |
|------------------------------------|--------------|
| <b>SCHEMATIC.....</b>              | <b>3</b>     |
| <b>ELECTRICAL.....</b>             | <b>4-5</b>   |
| <b>CHASSIS AND ENCLOSURES.....</b> | <b>6-7</b>   |
| <b>DRIVE.....</b>                  | <b>8-9</b>   |
| <b>SEAT.....</b>                   | <b>10</b>    |
| <b>DECALS.....</b>                 | <b>11</b>    |
| <b>STEERING WHEEL.....</b>         | <b>12-13</b> |
| <b>ENGINE.....</b>                 | <b>14</b>    |
| <b>MOWER LIFT.....</b>             | <b>15</b>    |
| <b>MOWER DECK.....</b>             | <b>16-17</b> |

# TRACTOR - - MODEL NUMBER RELTS1136A

## SCHEMATIC

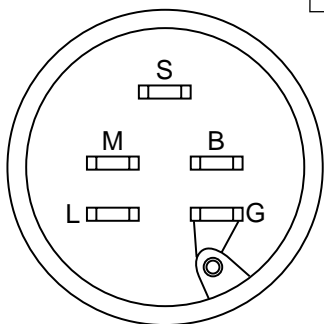
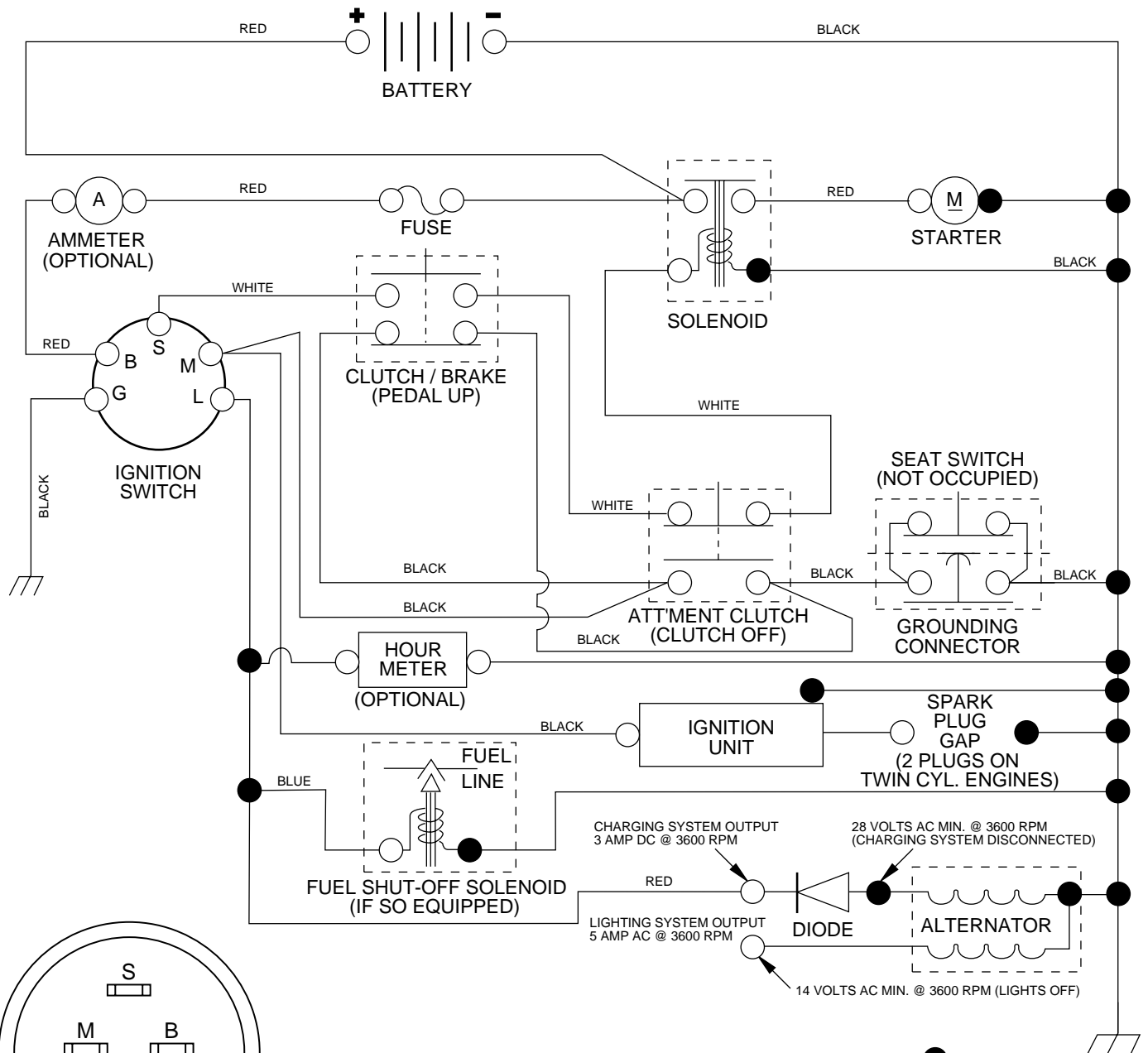

**IGNITION SWITCH**

| POSITION | CIRCUIT   |
|----------|-----------|
| OFF      | M + G     |
| ON       | B + L     |
| START    | B + S + L |

**WIRING INSULATED CLIPS**  
**NOTE:** IF WIRING INSULATED CLIPS WERE REMOVED FOR SERVICING OF UNIT, THEY SHOULD BE REPLACED TO PROPERLY SECURE YOUR WIRING.

●  
 NON-REMOVABLE CONNECTIONS

○  
 REMOVABLE CONNECTIONS



# REPAIR PARTS

## TRACTOR - - MODEL NUMBER RELTS1136A

### ELECTRICAL

| KEY NO. | PART NO. | DESCRIPTION                     |
|---------|----------|---------------------------------|
| 1       | 144925   | Battery 12 Volt 25 AMP          |
| 2       | 74760412 | Bolt Hex Hd 1/4-20unc X 3/4     |
| 8       | 156417   | Case Battery                    |
| 16      | 153664   | Switch Interlock Push-In        |
| 24      | 4799J    | Cable Battery                   |
| 25      | 146147   | Cable Battery 6 Ga 44" red      |
| 26      | 175158   | Fuse 20 AMP                     |
| 27      | 73510400 | Nut Keps Hex 1/4-20 Unc         |
| 28      | 4207J    | Cable Ground 6 Ga 12" black     |
| 29      | 121305X  | Switch Plunger Nc Gray          |
| 30      | 175567   | Switch Ign                      |
| 33      | 140401   | Key Ign                         |
| 40      | 175171   | Harness Ignition                |
| 41      | 71110408 | Bolt Blk Fin Hex 1/4 - 20 x 1/2 |
| 42      | 131563   | Cover Terminal Red              |
| 43      | 175141   | Solenoid                        |
| 48      | 140844   | Adapter Ammeter                 |
| 52      | 141940   | Protection Wire Loop            |

**NOTE:** All component dimensions give in U.S. inches  
1 inch = 25.4 mm.

# REPAIR PARTS

## TRACTOR - - MODEL NUMBER RELTS1136A

### CHASSIS AND ENCLOSURES

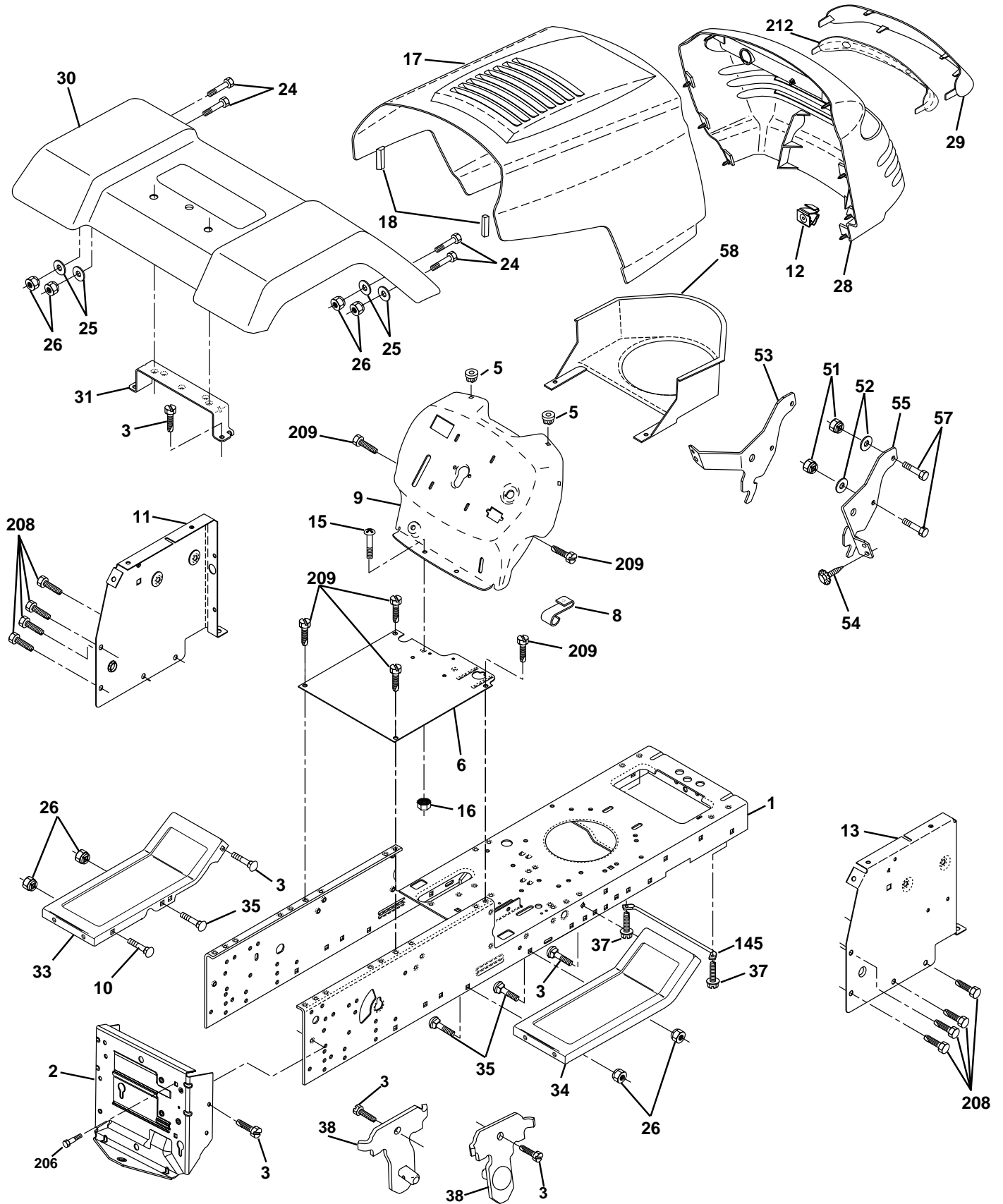

# REPAIR PARTS

## TRACTOR - - MODEL NUMBER RELTS1136A

### CHASSIS AND ENCLOSURES

| KEY NO. | PART NO.   | DESCRIPTION                             |
|---------|------------|---|
| 1       | 169831     | Chassis                                 |
| 2       | 169061     | Drawbar                                 |
| 3       | 17060612   | Screw 3/8-16 x 3/4                      |
| 5       | 155272     | Bumper Hood/Dash                        |
| 6       | 155924X010 | Saddle                                  |
| 8       | 155138     | Clip, Retainer Slide-On                 |
| 9       | 168347X011 | Dash                                    |
| 10      | 72140608   | Bolt, Carriage 3/8-16 x 1               |
| 11      | 155927     | Dashboard, panel LH                     |
| 12      | 145660     | Clip Tinnerman Grille P/L               |
| 13      | 172107X010 | Dashboard, panel RH                     |
| 15      | 74180512   | Machine screw 5/16-18 unc x 3/4         |
| 16      | 73510500   | Nut, Keps 5/16-18 Unc                   |
| 17      | 159639X505 | Hood Pnt Stl P/L w/Trim 505             |
| 18      | 126938X    | Bumper Hood                             |
| 24      | 74780616   | Bolt, Hex Head, Fin. 3/8-16 x 1 Grade 5 |
| 25      | 19131312   | Washer 13/32 x 13/16 x 12 Gauge         |
| 26      | 73800600   | Nut Lock Hex w/Ins. 3/8-16 Unc          |
| 28      | 157539     | Grille                                  |
| 29      | 150209X428 | Lens                                    |
| 30      | 169465X505 | Fender                                  |
| 31      | 136619     | Fender Bracket                          |
| 33      | 105476X505 | Footrest, LH                            |
| 34      | 105475X505 | Footrest, RH                            |
| 35      | 72110606   | Bolt 3/8-16 X 3/4                       |
| 37      | 17490508   | Screw Thdrol 5/16-18 x 1/2              |
| 38      | 169834     | Bracket Asm. Pivot Mower Rear           |
| 51      | 73800400   | Nut Lock, w/Insert 14/20 UNC            |
| 52      | 19091416   | Washer 9/32 x 7/8 x 16 Ga.              |
| 53      | 144697     | Bracket Grille                          |
| 54      | 161464     | Screw Hex WsHd 8-18 x 7/8               |
| 55      | 144696     | Bracket Grille RH                       |
| 57      | 74780412   | Bolt FinHex 1/4-20 UNC x .75            |
| 58      | 150127     | Duct Air Engine P/L LT                  |
| 145     | 156524     | Rod Pivot Chassis/Hood                  |
| 206     | 170165     | Bolt Shoulder 5/16-18 TT                |
| 208     | 17670608   | Screw Thdrol 3/8-16 x 1/2               |
| 209     | 17000612   | Screw Hexwsh Thdr 3/8-16 x 3/4          |
| 212     | 156494     | Insert Lens Reflect                     |
| --      | 5479J      | Button Plug                             |

**NOTE:** All component dimensions given in U.S. inches  
1 inch = 25.4 mm





# REPAIR PARTS

## TRACTOR - - MODEL NUMBER RELTS1136A

### DRIVE

| KEY NO. | PART NO. | DESCRIPTION   | KEY NO. | PART NO. | DESCRIPTION                       |
|---------|----------|---|---------|----------|-----------------------------------|
| 1       | -----    | Transaxle (See Breakdown)<br>Peerless, Model 204-506B<br>Order parts from transaxle<br>manufacturer | 47      | 127783   | Pulley, Idler                     |
| 2       | 146682   | Spring, Brake Return  | 48      | 154407   | Bellcrank Asm Clutch              |
| 3       | 123666X  | Pulley, Transaxle   | 49      | 123205X  | Retainer, Belt                    |
| 4       | 12000028 | Ring, Retainer  | 50      | 74760624 | Bolt, Hex 3/8-16 x 1-1/2          |
| 5       | 121520X  | Strap, Torque   | 51      | 73680600 | Nut, Crownlock 3/8-16             |
| 6       | 17060512 | Screw, 5/16-18 x 3/4 SMGML  | 52      | 73680500 | Nut, Crownlock 5/16-18            |
| 7       | 162240   | Bracket, T/A, Saddle Shift  | 53      | 105710X  | Link, Clutch                      |
| 8       | 131679   | Rod, Shifter  | 55      | 105709X  | Spring, Return, Clutch            |
| 10      | 76020416 | Pin, Cotter 1/8 x 1   | 56      | 74760620 | Bolt, Fin, Hex 3/8-16unc x 1-1/2  |
| 11      | 105701X  | Washer, Shift Plate   | 57      | 130801   | V-Belt, Drive                     |
| 12      | 19151216 | Washer 15/32 x 3/4 x 16   | 59      | 169691   | Keeper Belt Center Span           |
| 13      | 74550412 | Bolt 1/4-28 UNF Gr. 8 w/Patch   | 61      | 17060612 | Screw, 3/8-16 x 3/4 SMGML         |
| 14      | 10040400 | Washer Lock   | 62      | 8883R    | Cover, Foot Pedal                 |
| 18      | 74780616 | Bolt, Fin Hex 3/8-16 Unc x 1 Gr. 5  | 63      | 140186   | Pulley, Engine                    |
| 19      | 73800600 | Locknut 3/8-16  | 64      | 71170764 | Bolt, Hex 7/16-20 x 4 Gr. 5       |
| 21      | 106933X  | Knob  | 65      | 10040700 | Washer, Lock Hvy Hlcl Spr 7/16    |
| 22      | 130804   | Rod, Brake  | 66      | 154778   | Keeper, Belt Engine F-Proof       |
| 24      | 73350600 | Nut, Hex Jam 3/8-16   | 70      | 134683   | Guide Belt Mower Drive RH         |
| 25      | 106888X  | Spring, Rod, Brake  | 72      | 19132012 | Washer 13/32 x 1-1/4 x 12 Ga.     |
| 26      | 19131316 | Washer 13/32 x 13/16 x 16 Gauge   | 74      | 137057   | Spacer, Split                     |
| 27      | 76020412 | Pin, Cotter 1/8 x 3/4   | 75      | 121749X  | Washer 25/32 x 1-1/4 x 16 Ga.     |
| 28      | 145204   | Rod, Brake, Park  | 76      | 12000001 | E-Ring                            |
| 29      | 71673    | Cap, Plunger  | 77      | 123583X  | Key Square                        |
| 30      | 174973   | Bracket, Transaxle, L.H.  | 78      | 121748X  | Washer 25/32 x 1-5/8 x 16 Ga.     |
| 32      | 74760512 | Bolt Hex Hd 5/16-18 UNC x 3/4   | 79      | 2228M    | Key Woodruff #9 3/16 x 3/4        |
| 34      | 155071   | Shaft, Foot Pedal   | 96      | 4497H    | Retainer Spring 1" Ziinc/Cad      |
| 35      | 120183X  | Bearing Nylon   | 112     | 19091210 | Washer 9/32 x 3/4 x 10 Ga.        |
| 36      | 19211616 | Washer 21/32 x 1 x 16 Gauge   | 113     | 127285X  | Strap Torque L.H. Lt              |
| 37      | 1572H    | Pin, Roll 3/16 x 1  | 116     | 72110610 | Bolt, RdHd Sq Neck 3/8-16 x 1.25  |
| 38      | 131494   | Idler, Flat   | 120     | 73900600 | Nut Lock Flg. 3/8-16 Unc          |
| 39      | 74760644 | Bolt, RDHD 3/8-16unc x 2-3/4 Gr. 5  | 145     | 74490540 | Bolt, Hex Flghd 5/16-18 Gr. 5     |
| 40      | 4470J    | Spacer  | 150     | 165850   | Bushing, Bellcrank Grd Dr.        |
| 41      | 165838   | Keeper, Belt  | 151     | 19133210 | Washer 13/32 x 2 x 10 Ga.         |
| 42      | 19131312 | Washer 13/32 x 13/16 x 12 Gauge   | 170     | 173898   | Keeper, Belt, Transaxle GD.       |
|         |          |   | 202     | 72110612 | Bolt Carr Sh 3/8-16 x 1-1/2 Gr. 5 |
|         |          |   | 204     | 17060512 | Screw 5/16-18x 3/4                |

**NOTE:** All component dimensions give in U.S. inches.  
1 inch = 25.4 mm.

# REPAIR PARTS

## TRACTOR - - MODEL NUMBER RELTS1136A

### SEAT

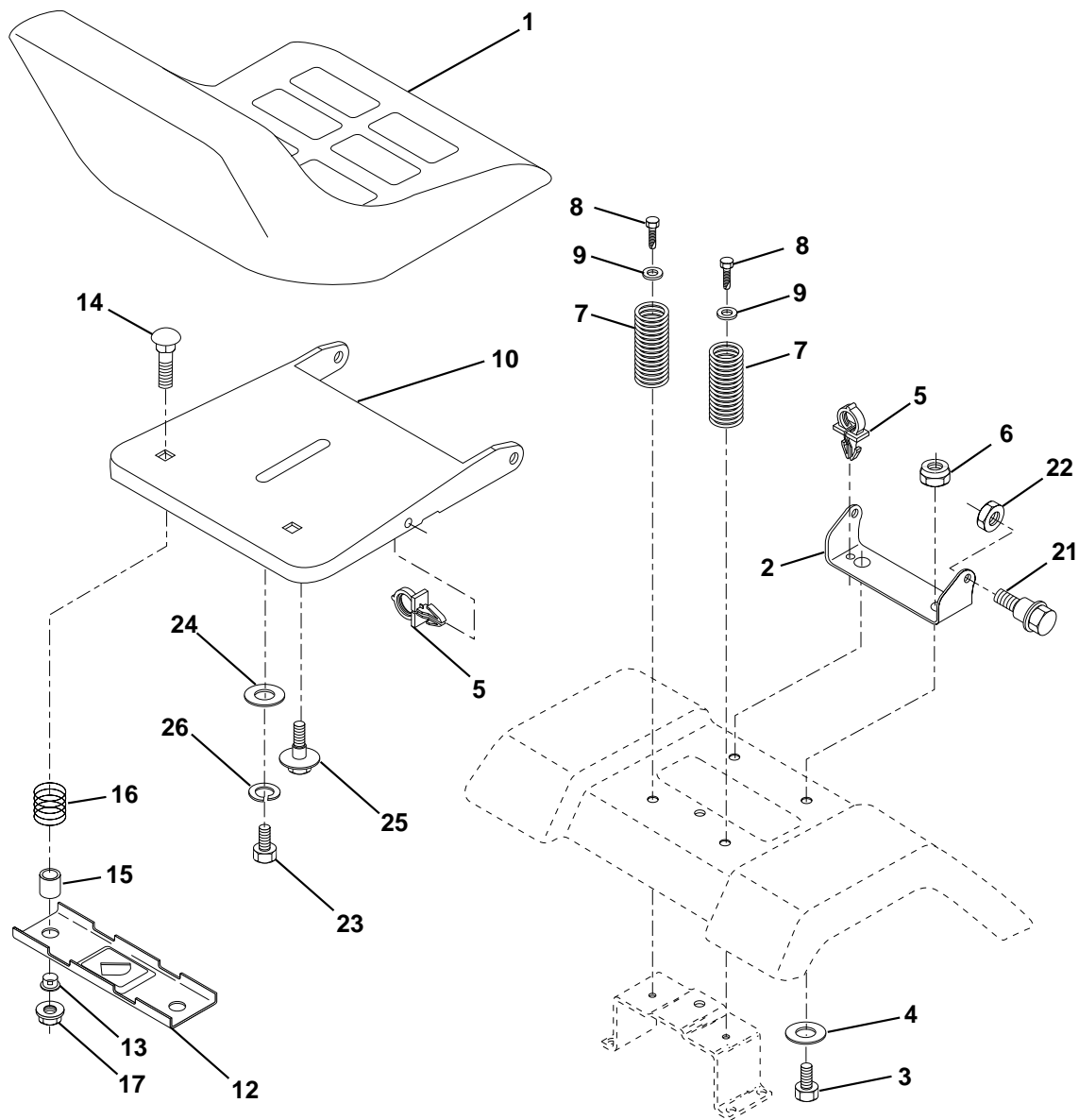

| KEY NO. | PART NO. | DESCRIPTION                     |
|---------|----------|---------------------------------|
| 1       | 127426X  | Seat                            |
| 2       | 140551   | Bracket, Pivot, Seat            |
| 3       | 71110616 | Fin Hex 3/8-16unc x 1           |
| 4       | 19131610 | Washer 13/32 x 1 x 10 Ga.       |
| 5       | 145006   | Clip, Push-in                   |
| 6       | 73800600 | Nut                             |
| 7       | 124181X  | Spring, Seat                    |
| 8       | 17000616 | Screw, 3/8-16 x 1.5 SMGML Tap/R |
| 9       | 19131614 | Washer 13/32 x 1 x 14 Ga.       |
| 10      | 174894   | Pan, Seat                       |
| 12      | 121246X  | Bracket, Mounting, Switch, Seat |
| 13      | 121248X  | Bushing, Nylon                  |

| KEY NO. | PART NO. | DESCRIPTION                    |
|---------|----------|--------------------------------|
| 14      | 72050412 | Nut, Crownlock 1/4-20 x 1-3/8  |
| 15      | 134300   | Spacer, Split                  |
| 16      | 121250X  | Spring                         |
| 17      | 123976X  | Nut, Lock, Flange 1/4 Gr. 5    |
| 21      | 171852   | Bolt, Shoulder 5/16-18 UNC-2A  |
| 22      | 73800500 | Nut                            |
| 23      | 71110814 | Bolt Hex Black                 |
| 24      | 19171912 | Washer 17/32 x 1-3/16 x 12 Ga. |
| 25      | 127018X  | Bolt Shoulder 5/16-18 x .62    |
| 26      | 10040800 | Washer Lock Hvy Hclc Spr 1/2   |

**NOTE:** All component dimensions given in U.S. inches  
1 inch = 25.4 mm

# REPAIR PARTS

## TRACTOR - - MODEL NUMBER RELTS1136A

### DECALS

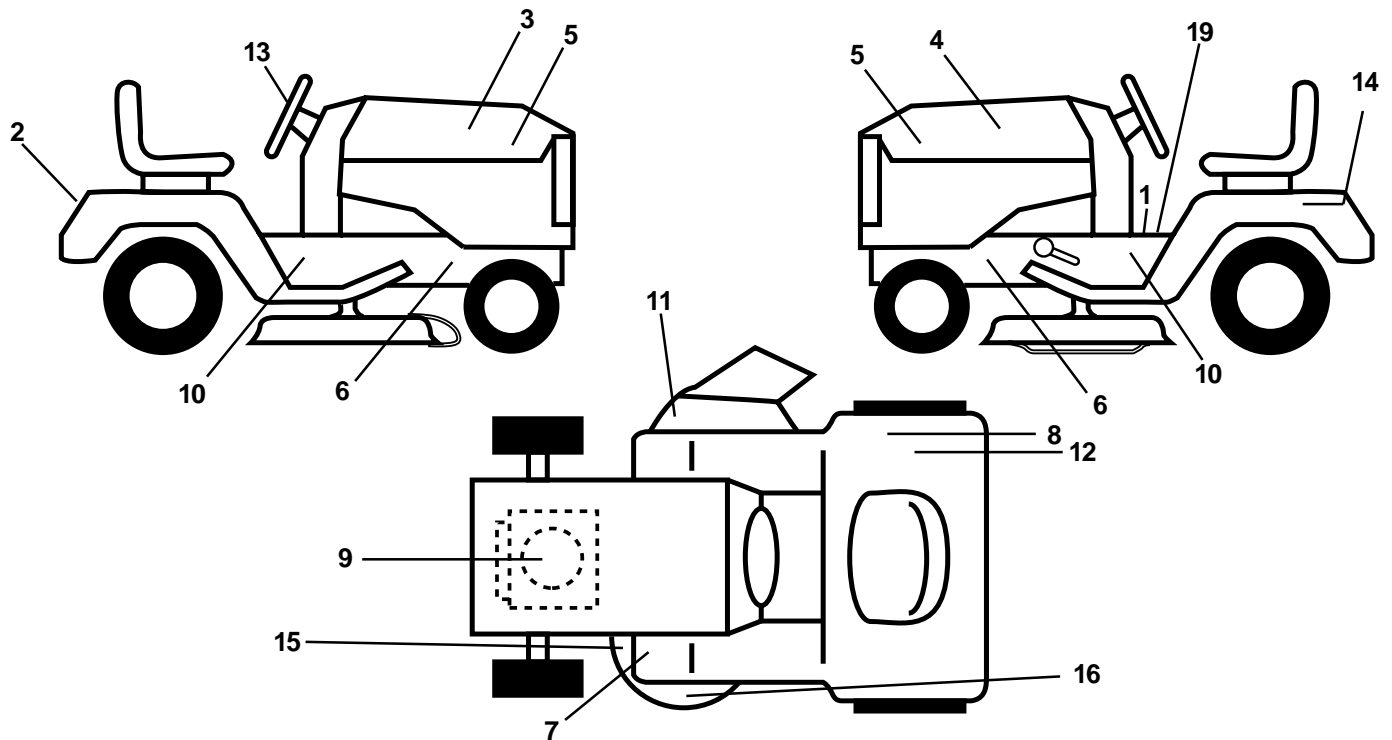

| KEY NO. | PART NO. | DESCRIPTION                   |
|---------|----------|-------------------------------|
| 1       | 145498   | Decal, Instruction, Operation |
| 2       | 170752   | Decal, Fender                 |
| 3       | 153266   | Decal, Hood R.H.              |
| 4       | 153267   | Decal Hood. L.H.              |
| 5       | 175698   | Decal Insert Hood             |
| 6       | 159736   | Decal, Chassis Hot Muffler    |
| 7       | 159737   | Decal, Brake/Clutch Symbol LT |
| 8       | 145437   | Decal, Europe Stand CE        |
| 9       | 170843   | Decal, HP Engine              |
| 10      | 157697   | Decal, Chassis                |
| 11      | 145494   | Decal, Mower Cutfinger Symbol |

| KEY NO. | PART NO. | DESCRIPTION                                      |
|---------|----------|--|
| 12      | 126187X  | Decal 100 DBA                                    |
| 13      | 127075   | Decal, Wheel Steering                            |
| 14      | 145005   | Decal, Btry Dngr/Psn P/L Sym                     |
| 15      | 136832   | Decal, V-Belt                                    |
| 16      | 134999   | Decal, Deck                                      |
| 19      | 140837   | Decal, Parking Brake                             |
| --      | 138311   | Decal, Handle, Lift, Height Adjust (Lift Handle) |
| --      | 162598   | Decal, Drawbar Load Limit                        |
| --      | 176902   | Manual, (Euro) Operator's                        |
| --      | 176903   | Manual, Repair Parts                             |

### TIRES AND WHEELS

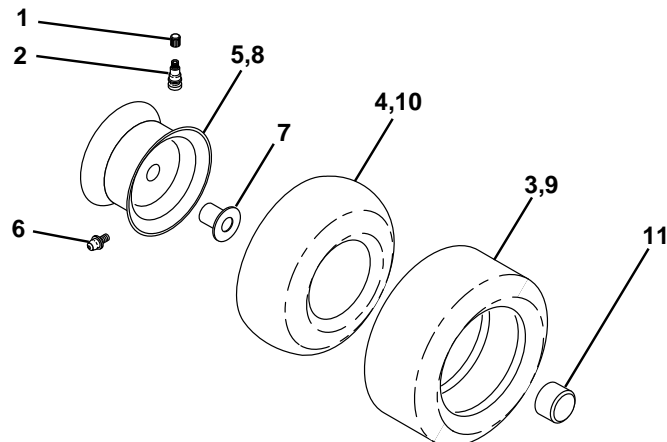

| KEY NO. | PART NO.   | DESCRIPTION                       |
|---------|------------|-----------------------------------|
| 1       | 59192      | Cap, Valve                        |
| 2       | 65139      | Stem, Valve                       |
| 3       | 124157X    | Tire Front                        |
| 4       | 59904      | Tube, Front (not furnished)       |
| 5       | 106732X427 | Rim, Asm. Front                   |
| 6       | 278H       | Grease Fitting (rear tire only)   |
| 7       | 9040H      | Bearing, Flange (front tire only) |
| 8       | 106108X427 | Rim, Asm. Rear                    |
| 9       | 123969X    | Tire, Rear                        |
| 10      | 7152J      | Tube, Rear (not furnished)        |
| 11      | 104757X428 | Cap, Axle                         |
| --      | 144334     | Sealant, Tire (10 oz. Tube)       |

**NOTE:** All component dimensions given in U.S. inches  
1 inch = 25.4 mm

# REPAIR PARTS

## TRACTOR - - MODEL NUMBER RELTS1136A

### STEERING WHEEL

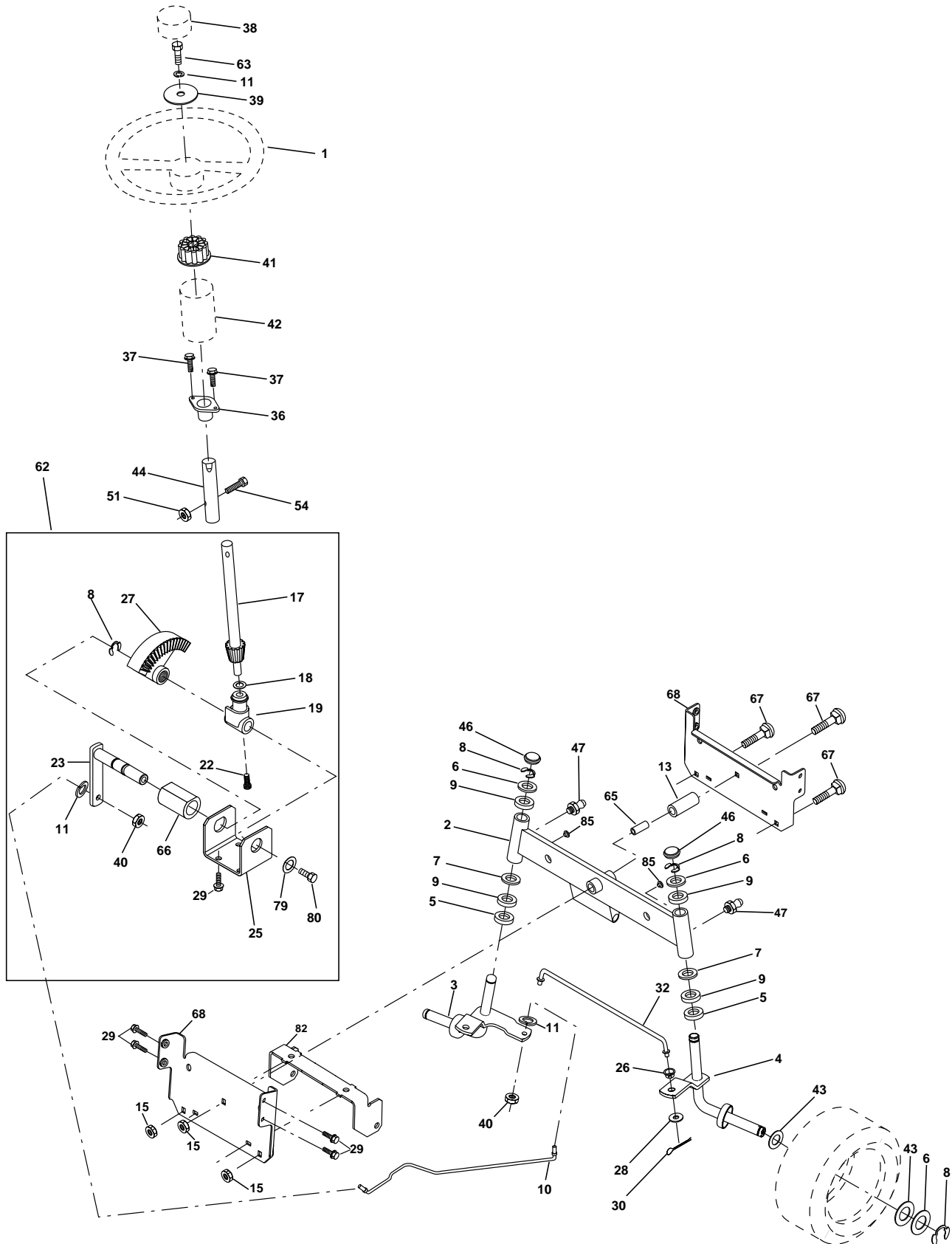

# REPAIR PARTS

## TRACTOR - - MODEL NUMBER RELTS1136A

### STEERING WHEEL

| KEY NO. | PART NO.   | DESCRIPTION                        |
|---------|------------|------------------------------------|
| 1       | 133741X428 | Wheel Steering                     |
| 2       | 154427     | Axle Asm Front                     |
| 3       | 169840     | Spindle Asm LH                     |
| 4       | 169839     | Spindle Asm RH                     |
| 5       | 6266H      | Bearing, Race, Thrust Hardened     |
| 6       | 121748X    | Washer 25/32 X 1-5/8 X 16 Ga       |
| 7       | 19272016   | Washer 27/32 X 1-1/4 X 16 Ga       |
| 8       | 12000029   | Ring Klip                          |
| 9       | 3366R      | Bearing                            |
| 10      | 169832     | Link Drag                          |
| 11      | 10040600   | Washer Lock Hvy Hlcl Spr 3/8       |
| 13      | 163518     | Spacer Brg. Axle Front             |
| 15      | 145212     | Nut Hexflange Lock                 |
| 17      | 156546     | Steering, Assembly Shaft           |
| 18      | 57079      | Washer Thrust 515x 750x 033        |
| 19      | 160395     | Support Shaft                      |
| 22      | 165857     | Screw Hex WSHHD Torx               |
| 23      | 165851     | Shaft Asm Pittman                  |
| 25      | 154406     | Bracket Steering                   |
| 26      | 126847X    | Bushing Link Drag Blk Lr           |
| 27      | 136874     | Gear Sector                        |
| 28      | 19131416   | Washer 13/32 x 7/8 x 16 Ga.        |
| 29      | 17060612   | Screw 3/8-16x3/4 SMGML Tap/R       |
| 30      | 76020412   | Pin Cotter 1/8 x 3/4 CAD           |
| 32      | 130465     | Rod Connecting                     |
| 36      | 155099     | Bushing Steering                   |
| 37      | 152927     | Screw TT #10-32 X 5 x 3/8 Flange   |
| 38      | 133742X428 | Cap Wheel Steering                 |
| 39      | 19133812   | Washer 13/32 x 2-3/8 x 12 Ga       |
| 40      | 7810H      | Nut Lock Center 3/8-24 Unf         |
| 41      | 100711L    | Adapter Wheel Strg                 |
| 42      | 145054X428 | Boot Steering                      |
| 43      | 121749X    | Washer 25/32 X 1 1/4 X 16 Ga       |
| 44      | 153720     | Extension Steering                 |
| 46      | 121232X    | Cap Spindle                        |
| 47      | 6855M      | Fitting Grease                     |
| 51      | 73800500   | Nut Lock Hex W/Ins. 5/16-18 Unc P  |
| 54      | 74780520   | Bolt Fin Hex 5/16-18 Unc 6 x 1-1/4 |
| 62      | 167902     | Kit Steering Asm. Service          |
| 63      | 74780616   | Bolt Fin Hex 3/8-16unc x 1 Gr. 5   |
| 65      | 160367     | Spacer Brace Axle                  |
| 66      | 154404     | Bearing Arm Pittman                |
| 67      | 72140618   | Bolt RDHD SQ 3/8-16UNC x 2-1/4     |
| 68      | 169827     | Brace Axle                         |
| 79      | 19132012   | Washer 13/32 x 1-1/4 x 12          |
| 80      | 74950612   | Bolt, Hex Nylon 3/8-16 x 3/4       |
| 82      | 169835     | Bracket Susp. Chassis Front        |
| 85      | 133835     | Fastener Christmas Tree            |

**NOTE:** All component dimensions given in U.S. inches  
1 inch = 25.4 mm

# REPAIR PARTS

## TRACTOR - - MODEL NUMBER RELTS1136A

### ENGINE

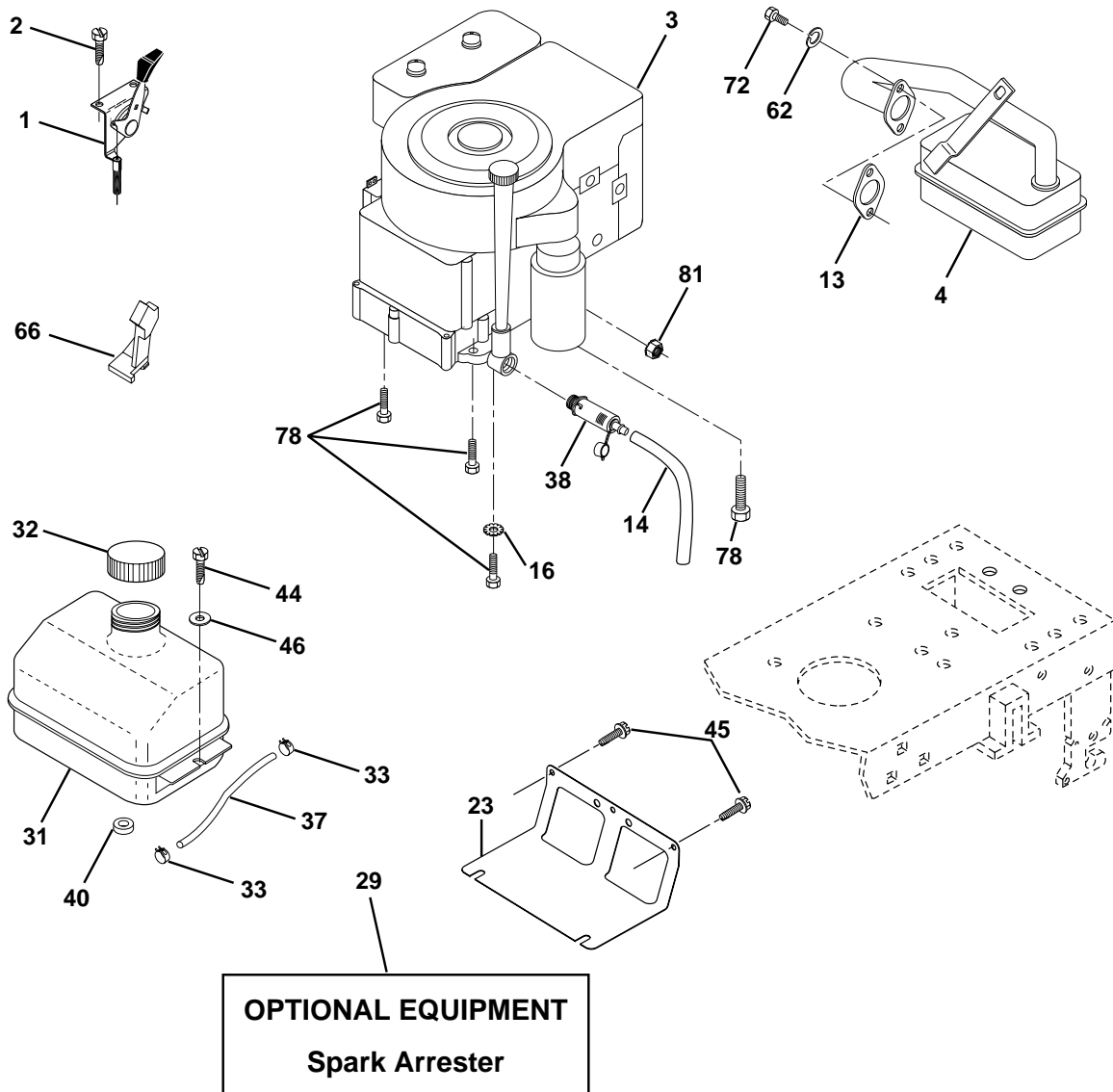

| KEY NO. | PART NO. | DESCRIPTION  |
|---------|----------|--|
| 1       | 170865   | Control Th/ch Flag EEC 20.22   |
| 2       | 17720410 | Screw Hex Thd Cut 1/4-20x5/8 T                                       |
| 3       | -----    | Engine Briggs Model 289707<br>(Order parts from engine manufacturer) |
| 4       | 137348   | Muffler LT   |
| 13      | 165291   | Gasket Eng 1 313 Id Tin Plated                                       |
| 14      | 148456   | Drain Oil Tube Easy  |
| 16      | 11050600 | Washer Lock Ext Tooth 3/8  |
| 23      | 169837   | Shield Brn/Dbr Guard   |
| 29      | 137180   | Kit Spark Arrester (Flat Scrn)                                       |
| 31      | 109202X  | Tank Fuel Front 2 00   |
| 32      | 140527   | Cap Asm Fuel   |
| 33      | 123487X  | Clamp Hose Blk   |

| KEY NO. | PART NO. | DESCRIPTION                     |
|---------|----------|---------------------------------|
| 37      | 137040   | Line Fuel                       |
| 38      | 148315   | Plug Drain Oil Easy             |
| 40      | 124028X  | Bushing Snap Nyl Blk Fuel Line  |
| 44      | 17670412 | Screw Hexwsh Thdrol 1/4-20x3/4  |
| 45      | 17000612 | Screw Hex Wsh Thdr 3/8-16 x 3/4 |
| 46      | 19091416 | Washer 9/32 X 7/8 X 16 Ga       |
| 62      | 10040500 | Washer 5/16                     |
| 66      | 127951   | Stop Throttle 3000 RPM          |
| 72      | 71070512 | Screw Hex Hd Cap 5/16-18 x 3/4  |
| 78      | 17060620 | Screw 3/8-16x1-1/4              |
| 81      | 73510400 | Nut Keps Hex 1/4-20 Unc         |

**NOTE:** All component dimensions given in U.S. inches.  
1 inch = 25.4 mm.

# REPAIR PARTS

## TRACTOR - - MODEL NUMBER RELTS1136A

### MOWER LIFT

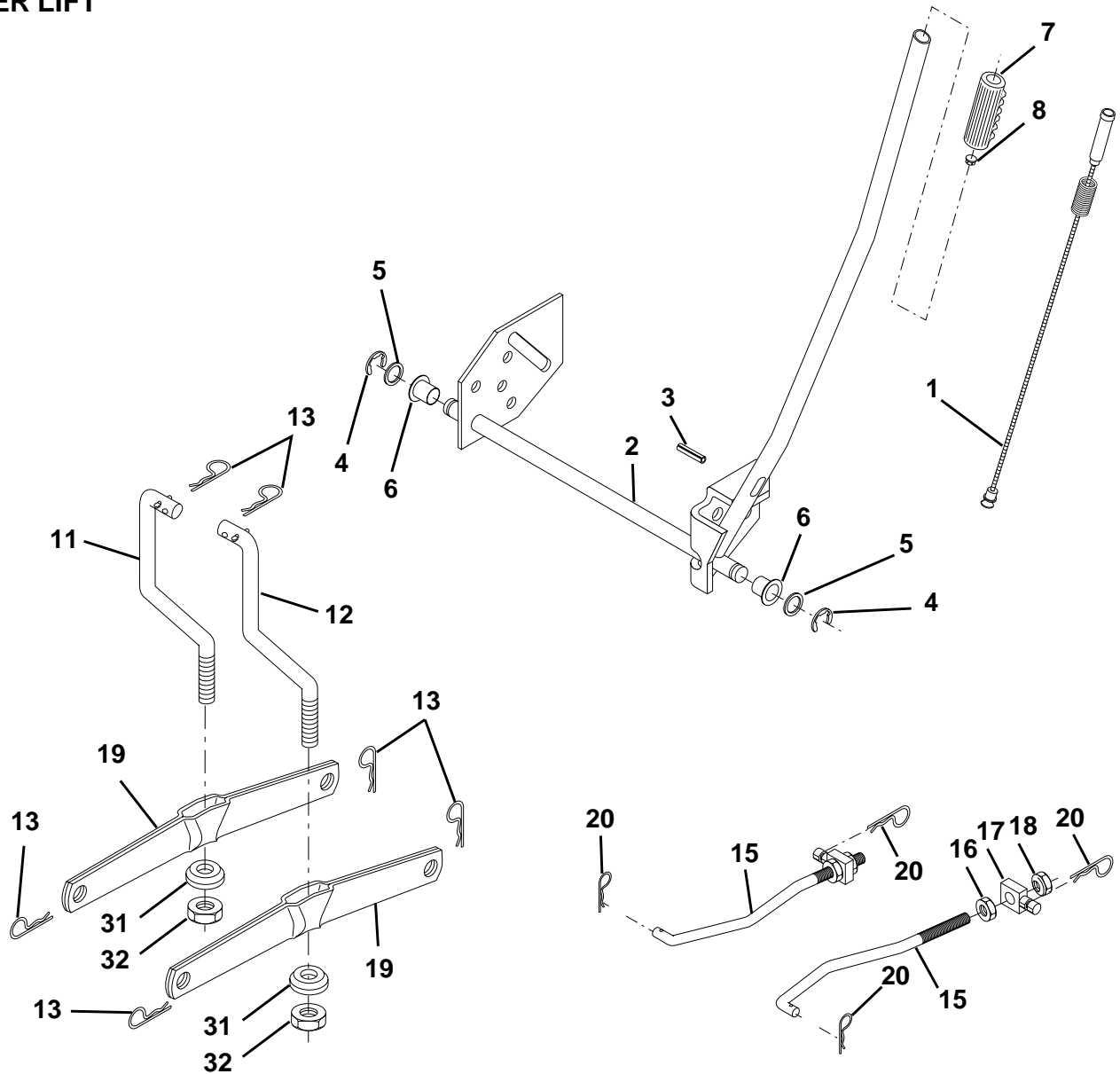

| KEY NO. | PART NO. | DESCRIPTION                    |
|---------|----------|--------------------------------|
| 1       | 159460   | Wire Asm. Inner/Sprg w/Plunger |
| 2       | 159471   | Shaft, Asm., Lift R/H          |
| 3       | 105767X  | Pin, Groove                    |
| 4       | 12000002 | Ring, E #5133-62               |
| 5       | 19211621 | Washer 21/32 x 1 x 21 Ga.      |
| 6       | 120183X  | Bearing, Nylon                 |
| 7       | 109413X  | Grip Handle Bicycle Matte Blk  |
| 8       | 124526X  | Button, Plunger                |
| 11      | 139865   | Link, Lift, Lh                 |
| 12      | 139866   | Link, Lift, Rh                 |
| 13      | 4939M    | Spring, Retainer               |

| KEY NO. | PART NO. | DESCRIPTION               |
|---------|----------|---------------------------|
| 15      | 173288   | Link, Front               |
| 16      | 73350800 | Nut, Jam, Hex 1/2-13 Unc  |
| 17      | 130171   | Trunnion                  |
| 18      | 73680800 | Nut, Crownlock 1/2-13 Unc |
| 19      | 139868   | Arm, Suspension, Rear     |
| 20      | 163552   | Spring, Retainer Zinc     |
| 31      | 169865   | Bearing, Pvt Lft          |
| 32      | 73540600 | Nut Crownlock 3/8-24      |

**NOTE:** All component dimensions given in U.S. inches  
1 inch = 25.4 mm

# REPAIR PARTS

## TRACTOR - - MODEL NUMBER RELTS1136A

### MOWER DECK

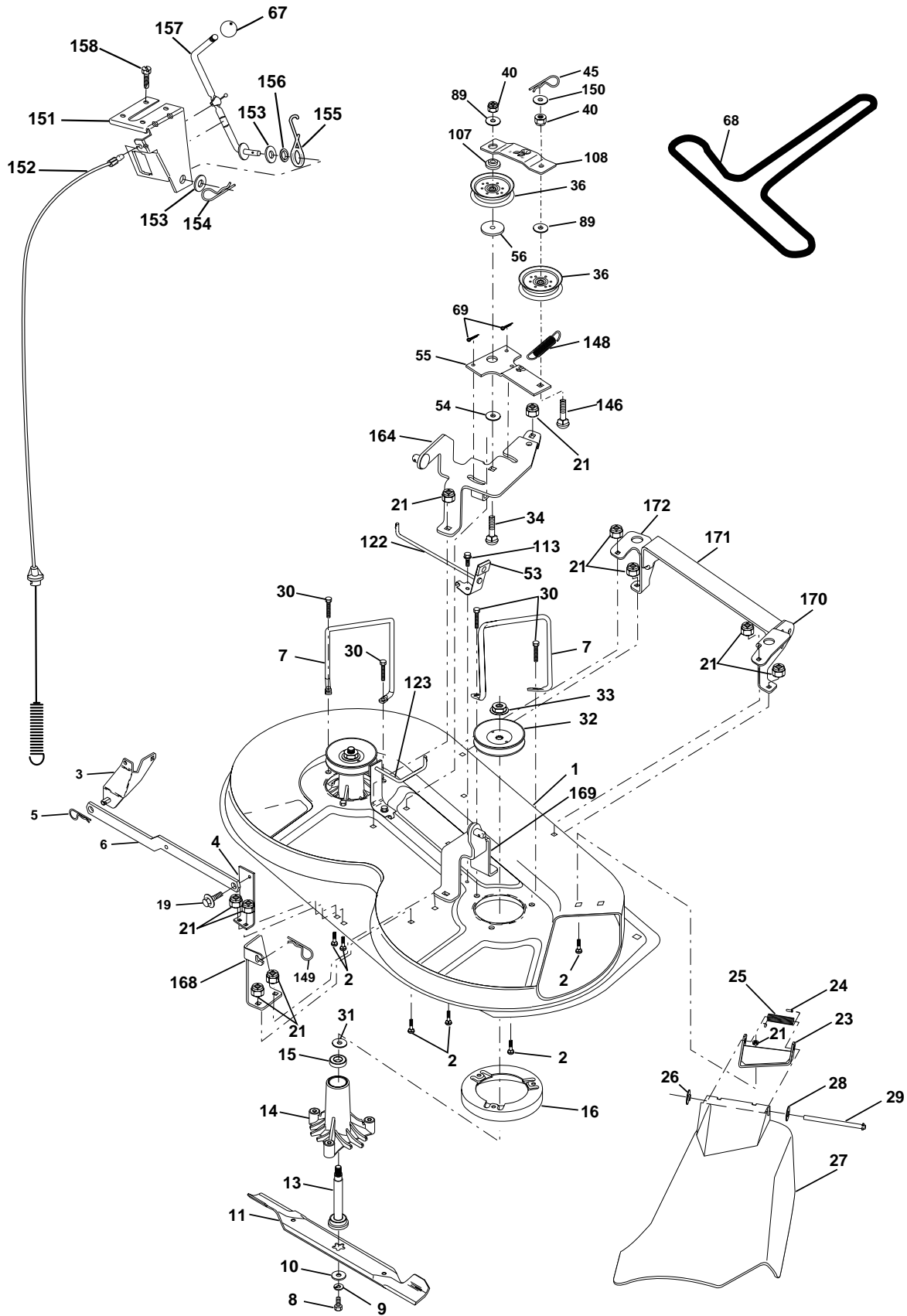



# REPAIR PARTS

## TRACTOR - - MODEL NUMBER RELTS1136A

### MOWER DECK

| KEY NO. | PART NO.   | DESCRIPTION   | KEY NO. | PART NO. | DESCRIPTION   |
|---------|------------|---|---------|----------|---|
| 1       | 174595     | Deck Asm Weldment                                     | 55      | 133840   | Arm, Idler Assembly                                     |
| 2       | 72140506   | Bolt  | 56      | 165723   | Spacer, Retainer  |
| 3       | 138017     | Asm., Bar, Anti-Sway                                  | 67      | 106932X  | Knob Rd 3/8-16 Plstc Thds Blk                           |
| 4       | 175654     | Bracket Sway Bar 36"                                  | 68      | 174978   | V-Belt, Mower   |
| 5       | 4939M      | Spring, Retainer                                      | 69      | 76020312 | Pin, Cotter 3/32 x 3/4                                  |
| 6       | 130832     | Arm, Suspension, Rear                                 | 89      | 19131612 | Washer 13/32 x 1 x 12 Ga.                               |
| 7       | 140608     | Keeper Belt Lh  | 107     | 133502   | Spacer, Retainer  |
| 8       | 850857     | Bolt 3/8-24 x 1.25 Gr. 8                              | 108     | 133503   | Stiffener, Idler Arm                                    |
| 9       | 10030600   | Washer, Lock  | 113     | 17490508 | Screw Thdrol 5/16-18 x 1/2                              |
| 10      | 140296     | Washer, Hardened                                      | 122     | 174505   | Rod, Brake, LH  |
| 11      | 138497     | Blade, Mower, Hi Lift                                 | 123     | 174504   | Rod, Brake, RH  |
| 13      | 137645     | Asm., Shaft, Mandrel, Vented<br>(Includes key no. 12) | 146     | 165891   | Bolt Carriage Idler                                     |
| 14      | 128774     | Housing, Mandrel, Vented                              | 148     | 169022   | Spring Return Idler                                     |
| 15      | 110485X    | Bearing, Ball, Mandrel                                | 149     | 165898   | Retainer Spring Yellow Zinc                             |
| 16      | 140329     | Stripper, Mower                                       | 150     | 19091216 | Washer 9/32 x 3/4 x 16 Ga.                              |
| 19      | 132827     | Bolt, Shoulder  | 151     | 169670   | Bracket Clutch Cable                                    |
| 21      | 73680500   | Nut, Crownlock 5/16 - 18 UNC                          | 152     | 176079   | Clutch Cable 38"/42"                                    |
| 23      | 136631     | Bracket, Deflector                                    | 153     | 169674   | Washer Flat 3/8" Type B                                 |
| 24      | 105304X    | Cap, Sleeve   | 154     | 169675   | Spring Retainer   |
| 25      | 123713X    | Spring, Torsion, Deflector                            | 155     | 169671   | Spring Retention Lvr Cltch Cab                          |
| 26      | 110452X    | Washer, Lock  | 156     | 169672   | Spacer Clutch Cable 3/8"                                |
| 27      | 175029X428 | Deflector, Shield                                     | 157     | 169669   | Rod Clutch Cable 3/8"                                   |
| 28      | 19111016   | Washer 1 1/32 x 5/8 x 16 Ga.                          | 158     | 17720410 | Screw Hex Thd Cut 1/4-20 x 5/8                          |
| 29      | 121980X    | Rod, Hinge  | 164     | 174976   | Bracket Asm Support Susp 36"                            |
| 30      | 157722     | Screw Hex Thdrol                                      | 168     | 172377   | Bracket Deck Cable 36"                                  |
| 31      | 129963     | Washer, Spacer  | 169     | 174977   | Bracket Asm Suspension                                  |
| 32      | 153531     | Pulley, Mandrel                                       | 170     | 172359   | Bracket Suspension RF                                   |
| 33      | 137266     | Nut Lock 9/16   | 171     | 165237   | Brace Support Susp Frt                                  |
| 34      | 72110614   | Bolt Rdhd 3/8-16 x 1-3/4                              | 172     | 172355   | Brace Suspension LF                                     |
| 36      | 131494     | Pulley, Idler, Flat                                   | --      | 130794   | Asm. Mandrel (includes key nos. 8-10, 12-15, 31 and 33) |
| 40      | 73680600   | Nut, Crownlock 3/8 - 16 UNC                           | --      | 175254   | Mower Deck, Complete                                    |
| 45      | 4497H      | Retainer Spring 1: Zinc/Cad                           |         |          |   |
| 53      | 130840     | Brake Assembly  |         |          |   |
| 54      | 133943     | Washer, Hardened                                      |         |          |   |

**NOTE:** All component dimensions given in U.S. inches  
1 inch = 25.4 mm



# SERVICE POLICY WARRANTY

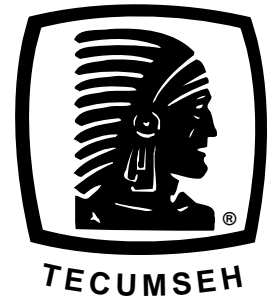

Issued January 1980  
Revised January 1991

## LIMITED WARRANTIES FOR NEW PEERLESS GEAR POWER TRAIN COMPONENTS

### A. Products Warranted

Peerless Gear and Machine Division of Tecumseh Products Company ("Tecumseh"), subject to the limitations contained below, at its option, repair or replace, without charge for parts or labor only, any part of a new Power Train Component (which as used herein means and includes the transaxle, gear box, transmission, differential and right angle drives, and any part of the Power Train Component), EXCEPT any new Power Train Component incorporated in equipment used for commercial or rental purposes, which is found upon examination by any Tecumseh Authorized Service Outlet or by Tecumseh's factory in Grafton, Wisconsin, to be DEFECTIVE IN MATERIAL AND/OR WORKMANSHIP if received by Tecumseh or a Tecumseh Authorized Service Outlet for such examination within TWO YEARS from the date of sale to the original consumer purchaser of Peerless Series 820, 900, 910, 915, 920, 930 transaxles and Series 1100 angle drive and ONE YEAR for all other Peerless products. New Power Train Components incorporated in equipment used for commercial purposes are warranted in the same manner and to the same extent EXCEPT such Power Train Components are warranted for NINETY (90) DAYS ONLY, and must be received by Tecumseh or by a Tecumseh Authorized Service Outlet for such examination within 90 days from the date of sale to the original purchaser. New Power Train Components incorporated in equipment used for rental purposes are warranted in the same manner and to the same extent EXCEPT such Power Train Components are warranted for THIRTY (30) DAYS ONLY, and must be received by Tecumseh or a Tecumseh Authorized Service Outlet within 30 days from the date of sale to the original purchaser.

### B. Products And Items Not Warranted

1. Alterations or Modifications of Power Train Components.
2. Accidents, Normal Maintenance, Failure to follow the Original Equipment Manufacturer's Manual.

This warranty covers only parts of new Power Train Components which are found upon examination to be defective in material or workmanship as delivered to the original purchaser. This warranty does not cover defects caused by depreciation or damage caused by normal wear, accidents, improper maintenance, improper use or abuse of the product, failure to follow the instructions contained in an Instruction Manual for the operation of the Power Train Component and parts. The cost of normal maintenance and replacement of service items which are not defective shall be paid for by the original purchaser.

### C. Securing Warranty Service

Warranty service can be arranged for by contacting either a Tecumseh Authorized Service Outlet (any Tecumseh Registered Service Dealer, Tecumseh Authorized Service Distributor, or Tecumseh Central Warehouse Distributor) or by contacting Tecumseh, c/o Service Manager, Engine and Transmission Group Service Division, 900 North Street, Grafton, Wisconsin 53024. Warranty service can only be performed by a Tecumseh Authorized Service Outlet or by Tecumseh at its factory in Grafton, Wisconsin. At the time of requesting warranty service, evidence must be presented of the date of sale to the original purchaser. The purchaser shall pay any charges for making service calls and/or for transporting the product to and from the place where the inspection and/or warranty work is performed. The purchaser shall be responsible for any damage or loss incurred in connection with the transportation of Power Train Components and/or part(s) of the Power Train Components submitted for inspection and/or warranty work.

### D. Limitation of Damages and Implied Warranties

The foregoing EXPRESSED WARRANTY IS IN LIEU OF ALL OTHER EXPRESS WARRANTIES. Neither Tecumseh nor any of its affiliates makes any warranties, representations or promises, written or oral, as to the quality of the Power Train Component or any of its parts, other than as set forth herein.

ANY IMPLIED WARRANTY OF MERCHANTABILITY OR FITNESS FOR A PARTICULAR PURPOSE, TO THE EXTENT THAT EITHER MAY APPLY TO ANY PART(S) OF POWER TRAIN COMPONENTS, SHALL BE LIMITED IN DURATION TO THE PERIODS OF THE EXPRESSED WARRANTIES DEFINED IN PARAGRAPH A HEREOF. IN NO EVENT WILL TECUMSEH BE LIABLE FOR ANY INCIDENTAL, CONSEQUENTIAL OR SPECIAL DAMAGES AND/OR EXPENSES. Some states do not allow limitations on how long an implied warranty lasts or the exclusion or limitation of incidental or consequential damages, so the above limitation(s) or exclusion(s) may not apply to you. This warranty gives you specific legal rights and you may also have other legal rights which vary from state to state.

### E. No Dealer Warranty

Tecumseh neither assumes nor authorizes any other person, natural or corporate, to assume for Tecumseh any other obligations or liabilities in connection with or with respect to any part(s) of a Power Train Component. The seller or dealer of part(s) of a Power Train Component has no authority, whatsoever, to make any representations or promises on behalf of Tecumseh or to modify the terms or limitations of Tecumseh's warranty in any way.