

2009

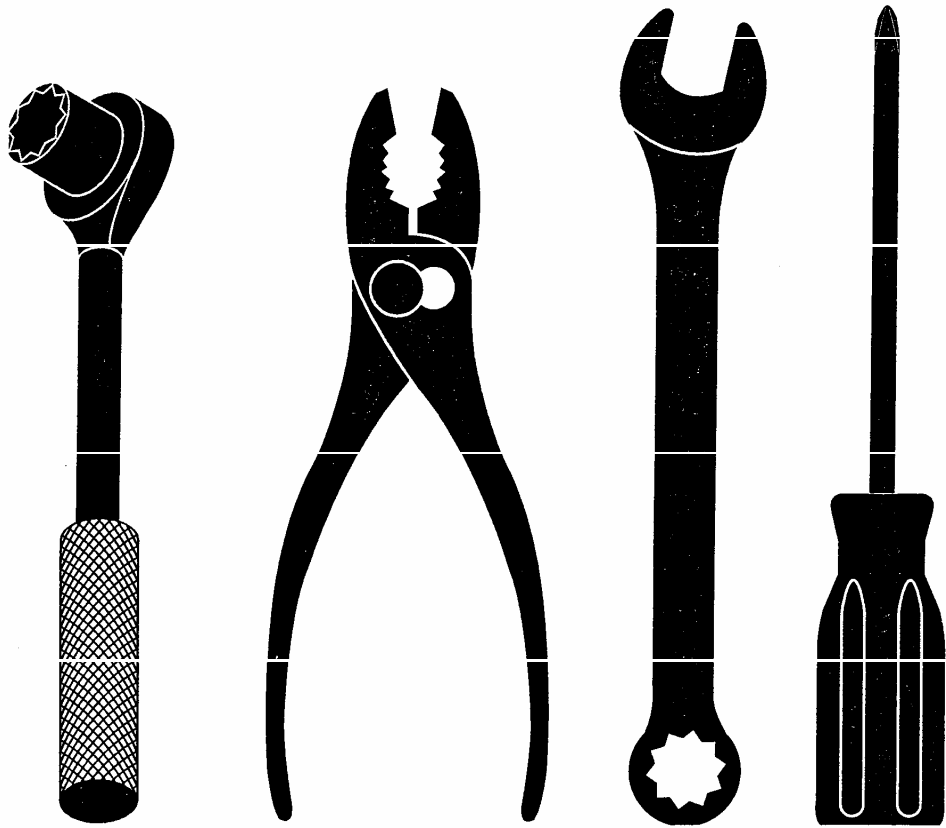

REPAIR PARTS MANUAL
MODEL NO. REN1192RB (REN1192RBA)
Lawn Tractor

Rally

00137

532 18 51-87 REV. 1 1.14.03 JH
PRINTED IN U.S.A.

HOW TO USE THIS MANUAL

This manual is designed to provide the customer with a means to identify the parts on his/her tractor when ordering repair parts. The illustrations may or may not represent the actual assemblies; therefore, it is not recommended to use this manual as a guide to assemble or disassemble the tractor. Some hardware and parts are drawn larger in order to more readily identify them.

Each tractor has its own model number.

The model number for your tractor can be found on the fender under the seat.

When ordering parts, always give the following information:

- Product - "Tractor"

- Model Number - "REN1192RB (REN1192RBA)"
- Part Number
- Part Description

TABLE OF CONTENTS

SCHEMATIC	3
ELECTRICAL	4-5
CHASSIS	6-7
DRIVE	8-9
STEERING	10-11
SEAT	12
DECALS	13
ENGINE	14
MOWER LIFT	15
MOWER DECK	i6-i7
BAGGER	18

TRACTOR - MODEL NO. REN1192RB (REN1192RBA), PRODUCT NO. 964 77 85-00 SCHEMATIC

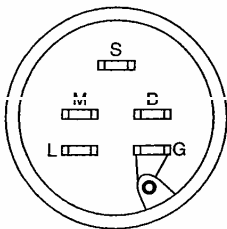
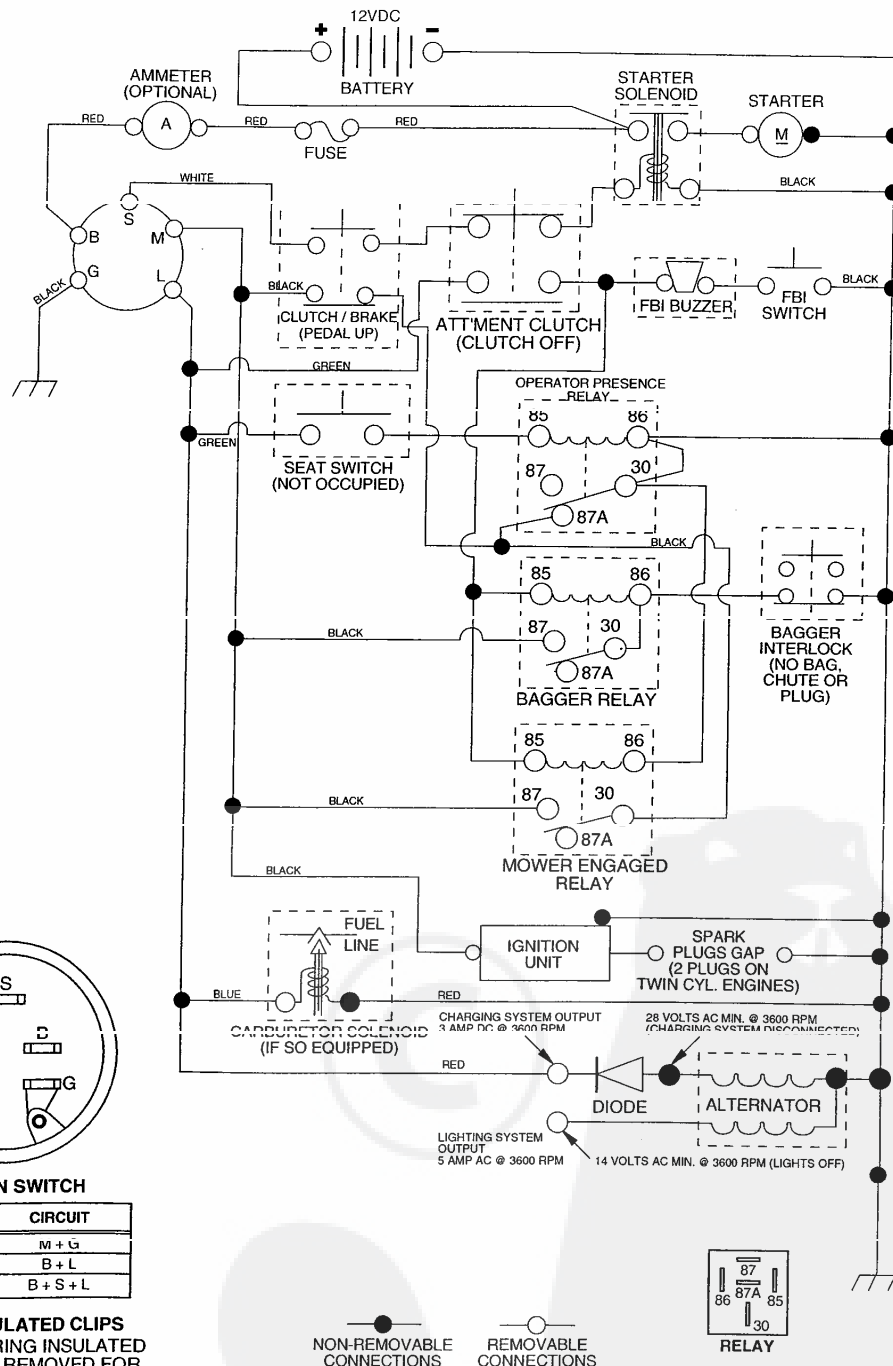

IGNITION SWITCH

POSITION	CIRCUIT
OFF	M + G
ON	B + L
START	B + S + L

WIRING INSULATED CLIPS
NOTE: IF WIRING INSULATED CLIPS WERE REMOVED FOR SERVICING OF UNIT, THEY SHOULD BE REPLACED TO PROPERLY SECURE YOUR WIRING.

● NON-REMOVABLE CONNECTIONS
○ REMOVABLE CONNECTIONS



REPAIR PARTS

TRACTOR- -MODEL NO. REN1192RB (REN1192RBA), PRODUCT NO. 964 77 85-00
ELECTRICAL

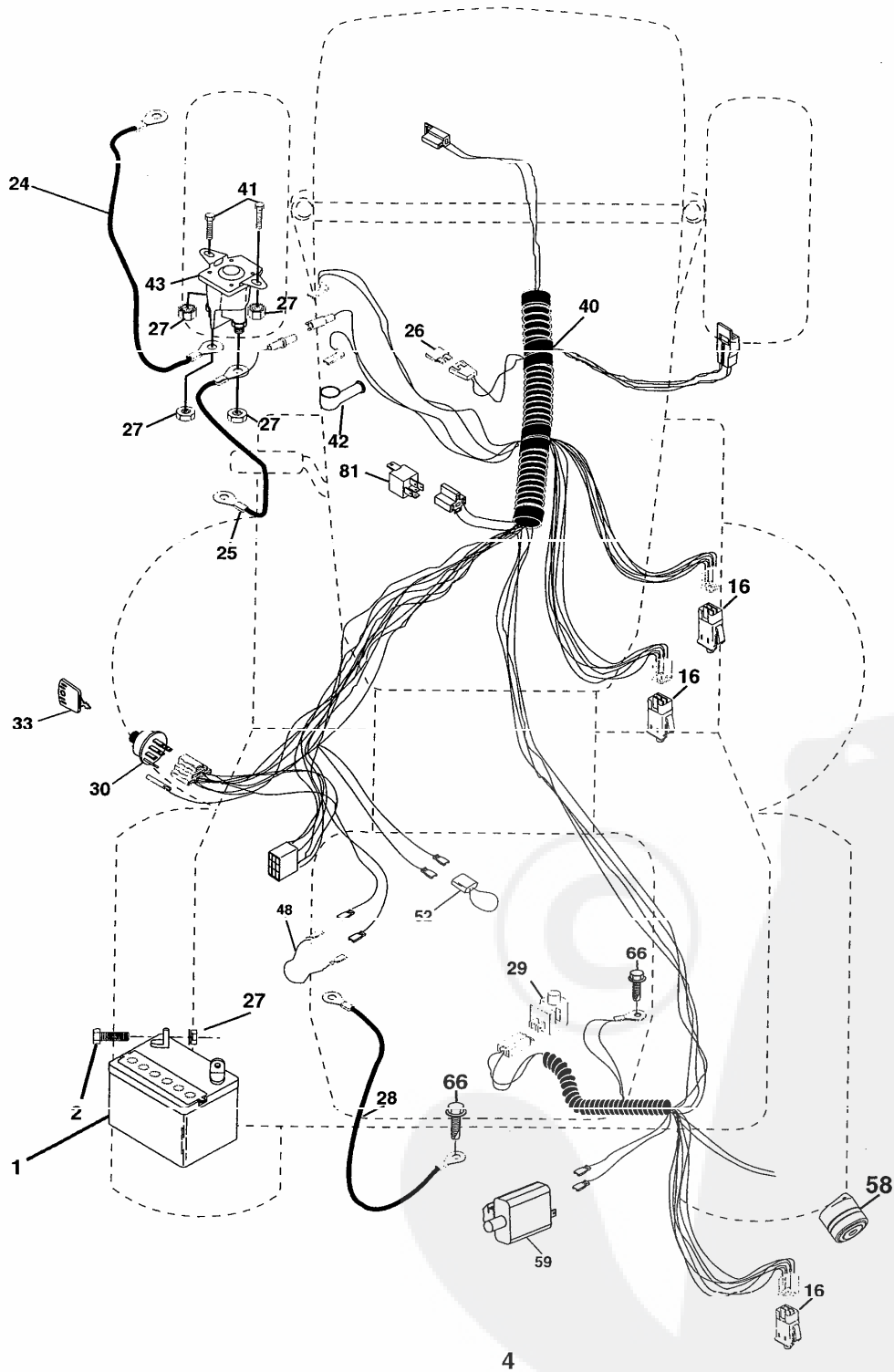

REPAIR PARTS

TRACTOR- -MODEL NO. REN1192RB (REN1192RBA), PRODUCT NO. 964 77 85-00
ELECTRICAL

KEY NO.	PART NO.	DESCRIPTION
1	532 16 34-65	Battery
2	874 76 04-12	Bolt Hex Hd 1/4-20 Unc X 3/4
16	532 17 61-38	Switch Interlock Push-In
24	532 12 47-80	Cable Starter 6Ga 11" Red
25	532 16 59-87	Cable Battery Crd 56" Red
26	532 17 51-58	Fuse 20 Amp
27	873 51 04-00	Nut Keps Hex 1/4-20 Unc
28	532 12 77-25	Cable Ground 6 Ga 18" Black
29	532 16 07-81	Switch Plunger Normal Op Olive
30	532 17 55-67	Switch Ignition
33	532 14 04-01	Key Ign
40	532 18 00-20	Harness Ign
41	871 11 04-08	Bolt Flk Fin Hex 1/4-20 Unc X 1/2
42	532 13 15-63	Cover Terminal Red
43	532 17 88-61	Solenoid
48	532 14 08-44	Adapter Ammeter Rectangular
52	532 14 19-40	Protection Wire Loop
58	532 16 04 10	Buzzer Crd
59	532 18 03-79	Switch FBI CRD
66	817 49 06-08	Screw Thdrol 3/8-16 x 1/2 Ty-Tt
81	532 10 97-48	Relay Asm

NOTE: All component dimensions given in U.S. inches.
1 inch = 25.4 mm.

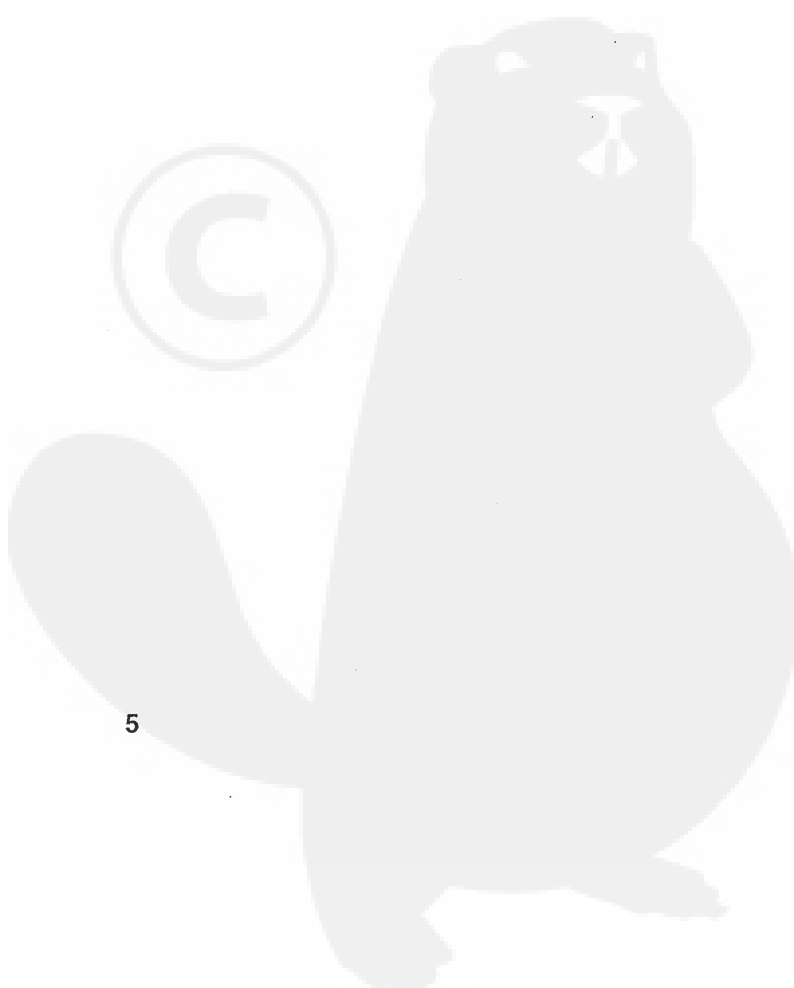
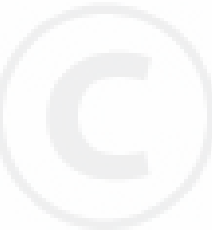

REPAIR PARTS

TRACTOR- -MODEL NO. REN1192RB (REN1192RBA), PRODUCT NO. 964 77 85-00
CHASSIS AND ENCLOSURES

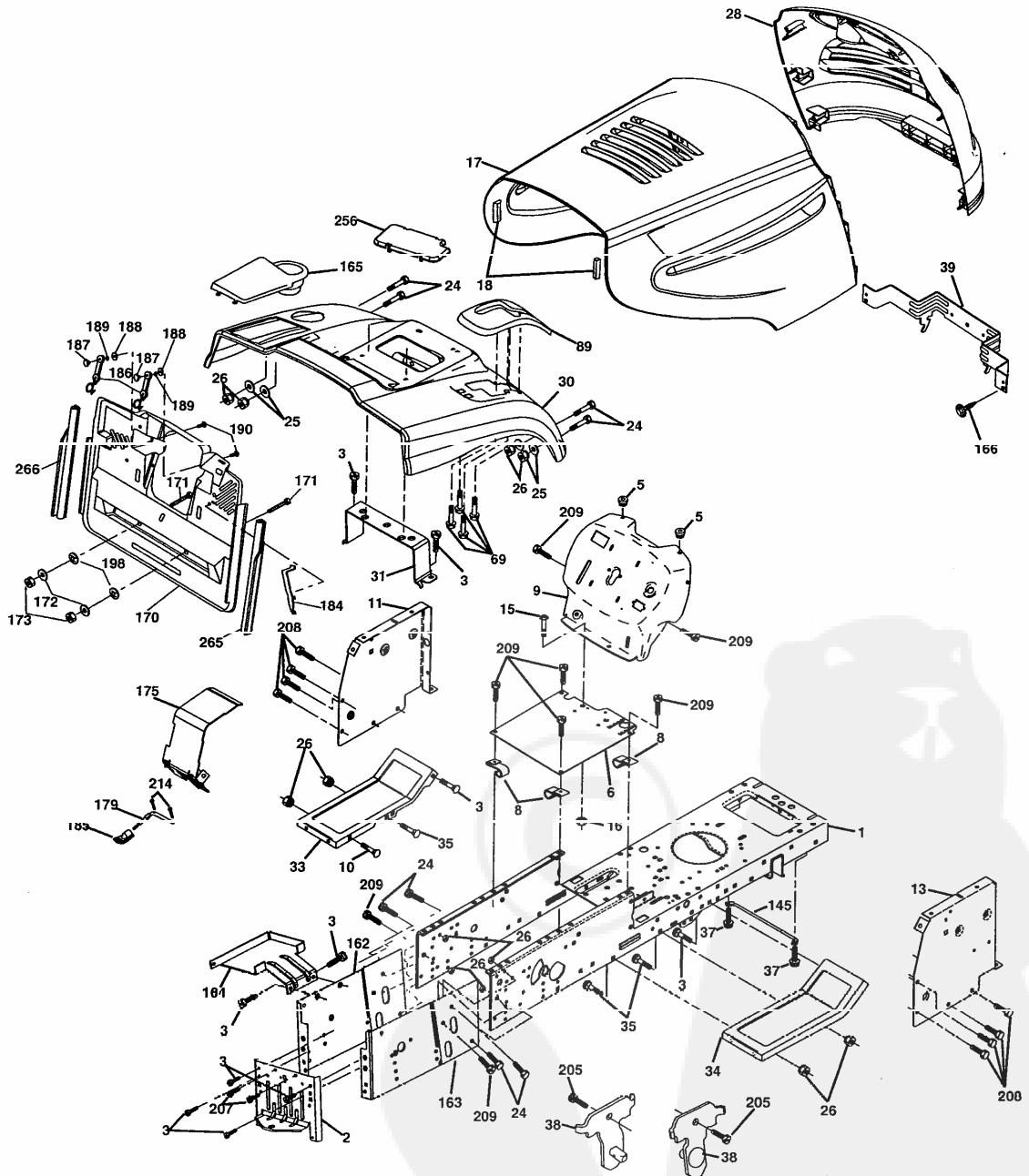

chassis-Elite_Basic_CRD_2.

REPAIR PARTS

TRACTOR- -MODEL NO. REN1192RB (REN1192RBA), PRODUCT NO. 964 77 85-00
CHASSIS AND ENCLOSURES

KEY NO.	PART NO.	DESCRIPTION	KEY NO.	PART NO.	DESCRIPTION
1	532 17 46-20	Chassis	164	532 16 56 05	Support Battery CRD
2	532 18 03-84	Drawbar	165	532 18 13-56	Cover Battery CRD Lt
3	817 06 06-12	Screw 3/8-16 x .75	166	532 17 18-75	Screw HWHD Hi-Lo #13-16 x 3/4
5	532 15 52-72	Bumper Hood/Dash	170	532 17 88-62	Backplate CRD
6	532 18 44-19	Saddle	171	872 14 06-20	Bolt Rdhd Sqnk 3/8-16 x 2-1/2 G5
8	532 12 64-71	Clip Insulator 13/32 Mtg. Hole	172	819 13 20-16	Washer 13/32 x 1-1/4 x 16 Ga.
9	532 18 54-80	Dash	173	873 51 06-00	Nut, Keps Hex 3/8-16 UNC
10	872 14 06-08	Bolt, Carriage 3/8-16 x 3/4	175	532 18 03-10	Trap Door CRD
11	532 17 49-96	Panel, Dash, L.H.	179	532 18 03-76	Rod Pivot FBI CRD
13	532 18 69-52	Panel, Asm. Dash R.H.	184	532 17 46-62	Bracket Actuator Bagger CRD
15	874 18 05-12	Screw, Machine, Truss Head 5/16-18 UNC x 3/4	185	532 18 11-01	Knob Rod
16	873 51 05-00	Nut	186	532 16 07-93	Latch Asm Multch Bagger
17	532 18 67-07	Hood Assembly	187	532 12 50-04	Nut Weld .327/.304 #10-24
18	532 12 69-38	Bumper Hood	188	819 06 12-16	Washer #10
24	874 78 06-16	Bolt	189	810 07 10-00	Washer Lock #10
25	819 13 13-12	Washer 13/32 x 13/16 x 12 Ga.	190	871 08 10-10	Screw Pan Hd Phillips 10-24 x 5/8
26	873 80 06-00	Nut	198	532 16 89-37	Nut Push
28	532 18 67-18	Grille Lens Asm	205	817 49 06-08	Screw 3/8-16 x 1/2
30	532 18 13-59	Fender	207	817 67 05-08	Screw 5/16-18 x 1/2
31	532 16 51-56	Bracket, Fender Support	208	817 67 06-08	Screw Thdrol 3/8-16 x 1/2
33	532 18 11-93	Footrest, L.H.	209	817 00 06-12	Screw Hex Wsh Thdrol 3/8-16 x 3/4
34	532 18 11-94	Footrest, R.H.	214	532 12 47-88	Retainer Spring 1"
35	872 11 06-06	Bolt	256	532 18 13-61	Cover Fender Rack CRD
37	817 49 05-08	Screw Thdrol 5/16-18 x 1/2 TYT	265	532 18 57-04	Seal RH Side Bagger
38	532 18 17-48	Bracket Asm Pivot Mower Rear	266	532 18 57-03	Seal LH Side Bagger
39	532 17 47-14	Bracket Pivot	--	532 00 54-79	Plug, Button
69	532 14 24-32	Screw Hex 1/4-1/2			
89	532 18 13-88	Console			
145	532 15 65-24	Rod Pivot Chassis/Hood			
162	532 18 03-82	Bracket Exten Chassis Lh CRD			
163	532 18 03-83	Bracket Exten Chassis Rh CRD			

NOTE: All component dimensions given in U.S. inches.
1 inch = 25.4 mm.

REPAIR PARTS

TRACTOR- -MODEL NO. REN1192RB (REN1192RBA), PRODUCT NO. 964 77 85-00
DRIVE

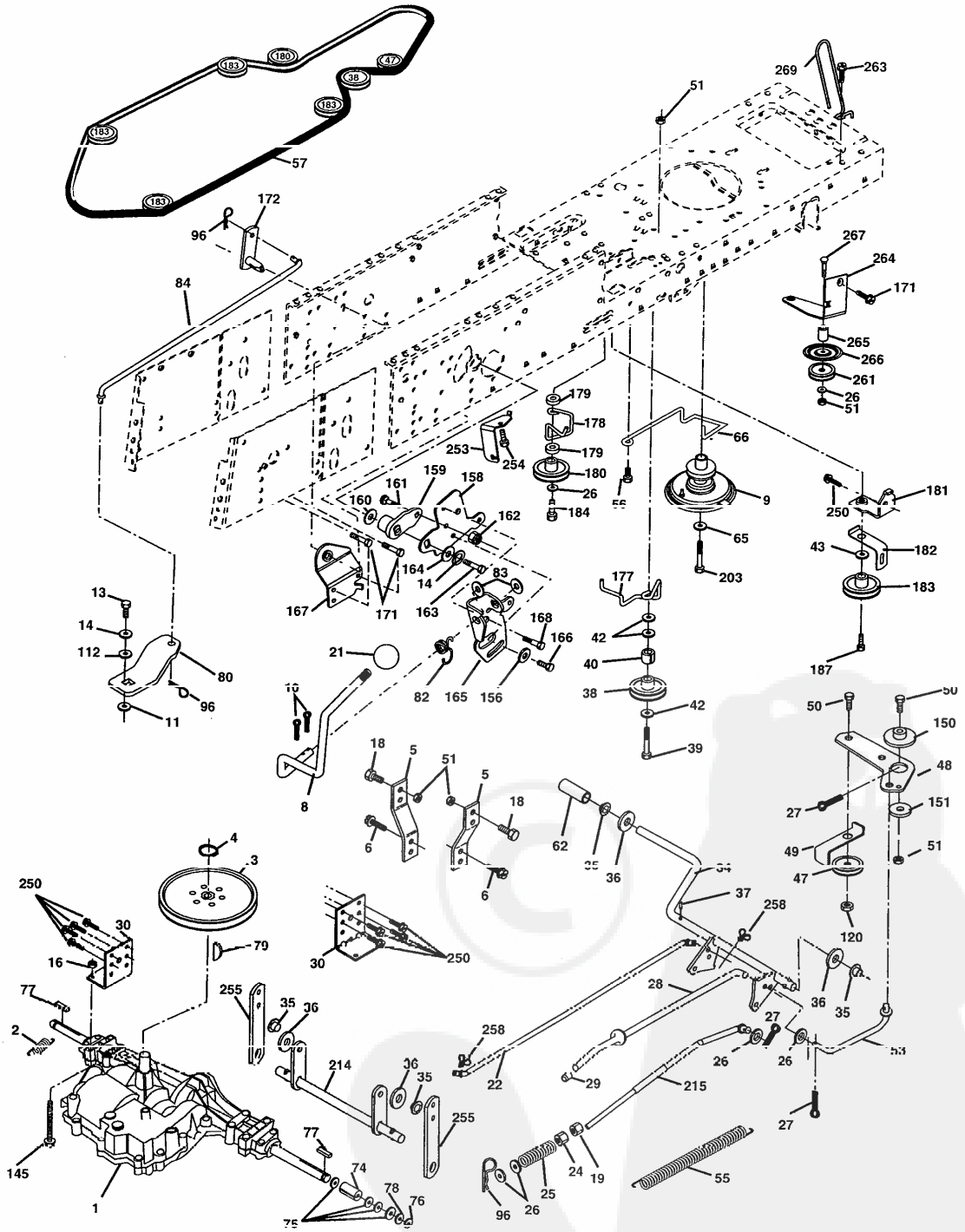

REPAIR PARTS

TRACTOR- -MODEL NO. REN1192RB (REN1192RBA), PRODUCT NO. 964 77 85-00
DRIVE

KEY NO.	PART NO.	DESCRIPTION	KEY NO.	PART NO.	DESCRIPTION
1	-----	Transaxle Peerless 206-546 Order parts from transaxle manufacturer	82	532 16 57-11	Spring, Torsion
2	532 14 66-82	Spring Brake Return	83	819 17 12-16	Washer 17/32 x 3/4 x 16 Ga.
3	532 16 59-99	Pulley Transaxle	84	532 16 56-21	Link Shift CHD Pmst 18" Tires
4	812 00 00-28	Ring Retainer #5100-62	96	532 12 47-88	Spring, Retainer 1"
5	532 12 15-20	Strap torque 30 degrees	112	819 09 12-10	Washer 9/32 x 3/4 x 10 Ga.
8	532 16 56-19	Rod Shift Fender Adjust Lt	120	873 90 06-00	Nut Lock 3/8-16
9	532 18 03-54	Clutch Asm Noram	145	874 49 05-40	Bolt Hex FGHD 5/16-18 x Gr 5
10	876 02 04-16	Pin, Cotter 1/8 x 1	150	532 16 58-50	Bushing, Bellcrank Grnd Dr
11	532 10 57-01	Washer Plate Shf .3888 sq hole	151	819 13 32-10	Washer 13/32 x 2 x 10 Ga.
13	874 55 04-12	Bolt 1/4-28 Unt Gr 8 w/patch	156	532 16 60-02	Washer Srrd 5/16 ID x 1.125
14	810 04 04-00	Washer, Lock Hvy Helical	158	532 16 55-89	Bracket Shift Mount
16	873 80 05-00	Nut, Lock Hex w/Ins 5/16-18 unc	159	532 18 39-00	Hub Tapered Flange Shift Lt
18	874 78 06-16	Bolt Hex 3/8-16 UNC x 1 Gr.5	160	819 29 20-16	Washer 29/32 x 1-1/4 x 16 Ga
19	873 80 06-00	Nut, Lock Hex w/Wsh 3/8-16 UNC	161	872 14 04-06	Bolt Rdhd Sqnk 1/4-20 x 3/4 Gr 5
21	532 10 69-33	Knob Round 1/2-13 Unc Blk	162	873 68 04-00	Nut Crownlock 1/4-20 Unc
22	532 17 56-07	Rod, Brake CRD Main	163	874 78 04-16	Bolt Hex Fin 1/4-20 Unc x 1 Gr 5
24	873 35 06-00	Nut	164	819 09 10-10	Washer 5/8 x .281 x 10 Ga.
25	532 10 68-88	Spring, Rod, Brake	165	532 16 56-23	Bracket Pivot Lever
26	819 13 13-16	Washer 13/32 x 13/16 x 16 Ga.	166	532 16 68-80	Screw 5/16-18 x 5/8
27	876 02 04-12	Pin, Cotter 1/8 x 3/4	167	532 16 55-88	Bracket Support Shift CRD
28	532 17 57-65	Rod, Parking Brake	168	532 16 54-92	Bolt Shoulder 5/16-18 x .561
29	532 07 16-73	Cap, Parking Brake	171	817 49 06-08	Screw Thdrol 3/8-16 x 1/2 Ty-Tt
30	532 17 49-73	Bracket, Mfg. Transaxle	172	532 16 56-35	Shaft Asm Shift Front CRD PMST
34	532 17 55-78	Shaft, Asm Pedal Foot CRD	177	532 16 59-32	Keeper Flat Idler 3.06" CRD
35	532 12 01-83	Bearing, Nylon	178	532 16 59-33	Keeper Belt Idler 1.88" CRD
36	819 21 16-16	Washer 21/32 x 1 x 16 Ga.	179	532 12 09-58	Washer Sintered
37	532 12 49-63	Pin, Roll 3/16 x 1"	180	532 16 56-30	Pulley Flat Composite 3.06"
38	532 16 59-36	Pulley, Flat	181	532 18 02-11	Bracket Idler Ground Drive CRD
39	874 76 06-44	Bolt Fin Hex 3/8-16 Unc x 2-3/4	182	532 18 26-82	Keeper Belt 2.5" Od V-Idler CRD
40	532 12 49-65	Spacer, Split 395 x 59 Bzp	183	532 18 60-07	Pulley V-Idler 2.50" Od CRD
42	819 13 13-12	Washer 13/32 x 13/16 x 12 Ga.	184	817 49 06-44	Screw Hexwsh Thdrol 3/8-16 x 2-3/4
43	819 11 10-12	Washer 11/32 x 5/8 x 12 Ga.	187	817 58 05-20	Screw 5/16-18 x 1.25
47	532 12 77-83	Pulley, Idler, V Groove Plasic	203	871 17 07-80	Bolt Hex 7/16-20 x 5
48	532 15 44-07	Bellcrank Clutch Grnd Drv	214	532 17 56-09	Shaft Asm. Brake
49	532 12 32-05	Retainer, Belt Style Spring	215	532 17 56-51	Rod Brake Secondary
50	872 11 06-12	Bolt Carr Sh 3/8-16 x 1-1/2 Gr 5	250	817 06 06-12	Screw 3/8-16 x .75
51	873 68 06-00	Nut, Crownlock 3/8-16 UNC	253	532 17 50-28	Bracket Cable Chassis
53	532 10 57-10	Link, Clutch 7.66	254	817 00 06-16	Screw 3/8-16 x 1
55	532 10 57-09	Spring, Return, Clutch	255	532 17 56-08	Brace Shaft Brake
56	817 06 06-20	Screw 3/8-16 x 1-1/4	258	532 17 80-62	Clip Retainer
57	532 16 56-31	V-Belt Kev PMST CRD	261	532 13 14-94	Pulley Idler Flat Plated
62	532 12 48-72	Cover, Pedal	263	817 00 06-12	Screw Hex Wsh THDR 3/8-16 x 3/4
65	810 04 07-00	Washer	264	532 18 19-95	Bracket Clutch
66	532 15 47-78	Keeper, Belt Engine F-Proof	265	532 18 20-13	Spacer Idler Chassis
74	532 13 70-57	Spacer Axle	266	532 18 20-61	Shield Idler
75	532 12 17-49	Washer 25/32 x 1-1/4 x 16 Ga.	267	872 14 06 26	Bolt Rd Sqk 3/8-16 x 3-1/4
76	812 00 00-01	Ring, E	269	532 18 24-02	Guard Muffler OHV B&S RH
77	532 12 35-83	Key, Square			
78	532 12 17-48	Washer 25/32 x 1-5/8 x 16 Ga.			
79	532 12 50-96	Key Woodruff			
80	532 14 50-90	Arm Shift PMST 20" Tires			

NOTE: All component dimensions given in U.S. inches
1 inch = 25.4 mm

REPAIR PARTS

TRACTOR- -MODEL NO. REN1192RB (REN1192RBA), PRODUCT NO. 964 77 85-00
STEERING ASSEMBLY

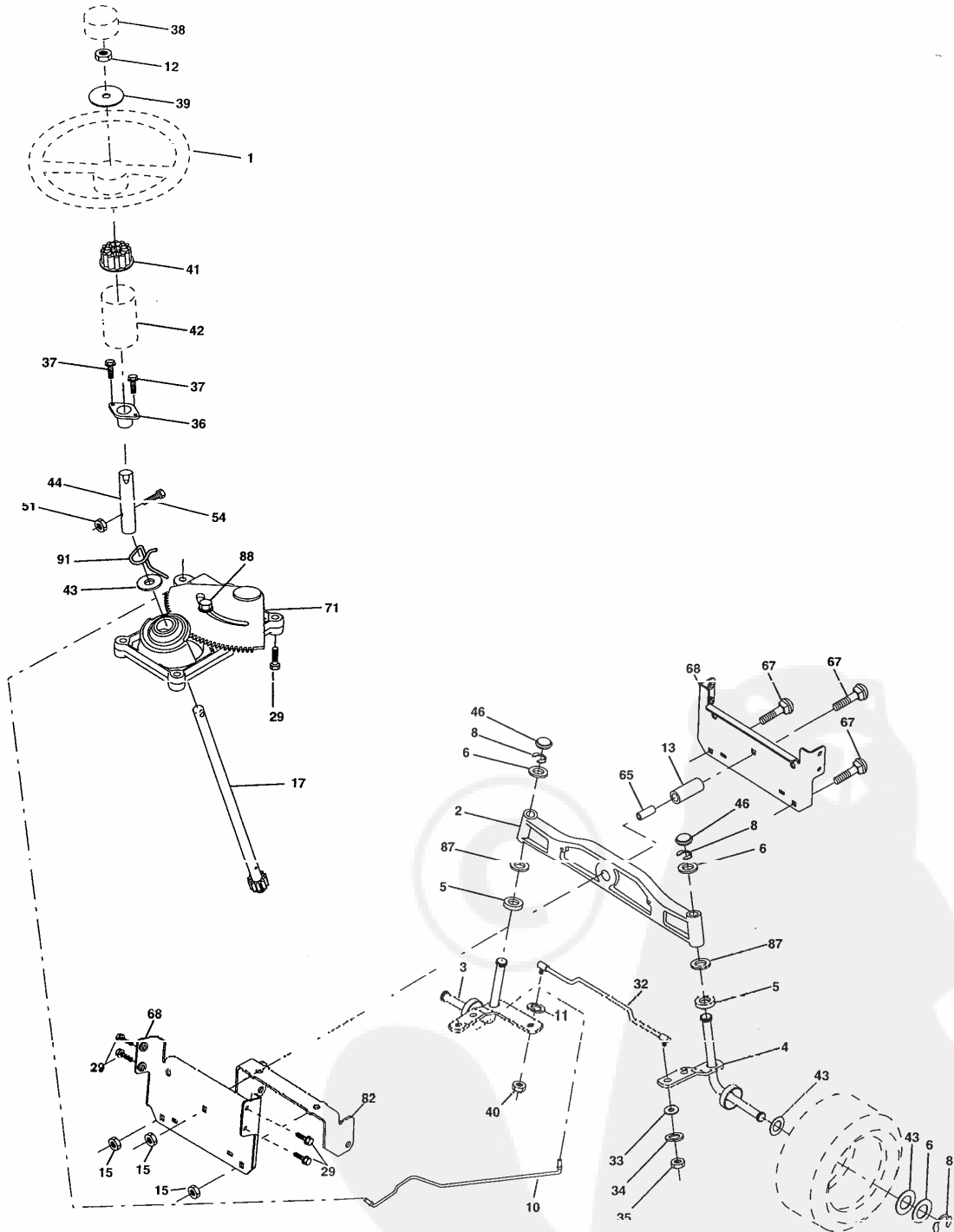

REPAIR PARTS

TRACTOR- -MODEL NO. REN1192RB (REN1192RBA), PRODUCT NO. 964 77 85-00
STEERING ASSEMBLY

KEY NO.	PART NO.	DESCRIPTION
1	532 13 97-68	Steering Wheel
2	532 17 23-93	Cast Iron Axle Assembly
3	532 16 98-40	Spindle Assembly, L.H.
4	532 16 98-39	Spindle Assembly, R.H.
5	532 12 49-31	Bearing, Race, Thrust, Hardened
6	532 12 17-48	Washer 25/32 x 1-5/8 x 16 Gauge
8	812 00 00-29	Ring, Klip
10	532 17 51-21	Link, Drag
11	810 04 06-00	Washer, Lock
12	873 94 08-00	Nut Hex Jam Toplock 1/2-20
13	532 13 65-18	Spacer Brg Axle Front
15	532 14 52-12	Nut, Hexflange Lock
17	532 18 06-41	Shaft Assembly, Steering
29	817 06 06-12	Screw, 3/8-16 x 3/4
32	532 17 01-62	Rod, Tie
33	819 11 12-16	Washer 11/32 x 3/4 x 16 Ga
34	810 04 05-00	Washer Lock Hvy Hicl Spr 5/16
35	873 54 05-00	Nut Crownlock 5/16-24 Unf
36	532 15 50-00	Rushing, Steering
37	532 15 29-27	Screw TT #10-32 x 5 x 3/8 Flange
38	532 14 01-75	Cap Wheel Steer
39	819 18 38-12	Washer 9/16 x 2-3/8 x 12 Ga
40	532 12 47-01	Nut Lock Center 3/8-24 Unf
41	532 10 07-11	Adaptor, Steering Wheel
42	532 16 96-33	Boot, Steering Dash P/L Mtl
43	532 12 17-49	Washer 25/32 x 1-1/4 x 16 Gauge
44	532 18 06-40	Extension Steering
46	532 12 12-32	Cap, Spindle
51	873 54 04-00	Nut Crownlock 1/4-28
54	871 13 04-20	Bolt Hex 1/4-28unf x 1-1/4
65	532 16 03-67	Spacer Brace Axle
67	872 14 06-18	Bolt Rdhd Sq 3/8-16 UNC x 2-1/4
71	532 17 51-46	Steering Asm.
68	532 16 98-27	Brace Axle
82	532 16 98-35	Bracket Susp Chassis Front
87	532 17 39-66	Washer Flat .781 x 1-1/2 x .14
99	532 17 51 13	Bolt Shoulder 7/16-20 Unc
91	532 17 55-53	Clip Steering

NOTE: All component dimensions given in U.S. inches.
1 inch = 25.4 mm.

REPAIR PARTS

TRACTOR- -MODEL NO. REN1192RB (REN1192RBA), PRODUCT NO. 964 77 85-00
SEAT ASSEMBLY

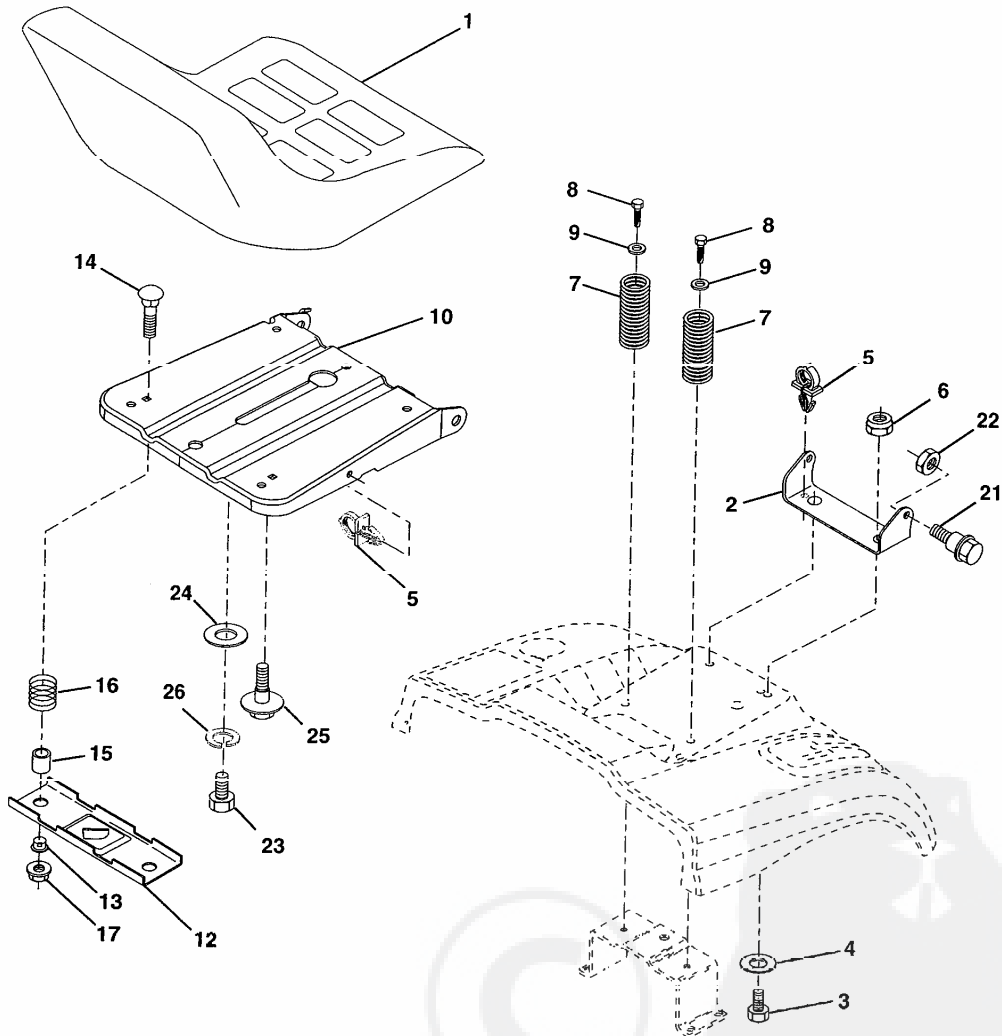

KEY NO.	PART NO.	DESCRIPTION
1	532 17 53-89	Seat
2	532 14 05-51	Bracket Pnt Pivot Seat (blk)
3	971 11 09 19	Bolt Fin Hex 3/8-16 Unc x 1
4	819 13 16-10	Washer Flat 13/32 x 1 x 10 Ga.
5	532 14 50-06	Clip Push In Hinged
6	873 80 06-00	Nut Lock Hex 3/8-16 Unc
7	532 12 41-81	Spring Seat Cprsn 2 250 Blk Zi
8	817 00 06-16	Screw 3/8-16 X 1-1/2
9	819 13 16-14	Washer 13/32 X 1 X 14 Ga
10	532 18 24-93	Pan Pnt Seat (blk)
12	532 12 12-46	Bracket Pnt Mounting Switch
13	532 12 12-46	Bushing Snap Blk Nyl 50 Id

KEY NO.	PART NO.	DESCRIPTION
14	872 05 04-12	Bolt Rdhd Sht Nk 1/4-20x1-1/2
15	532 13 43-00	Spacer Split
16	532 12 12-50	Spring Cprsn Plate SW 1.310 Ga
17	532 12 39-76	Nut Lock 1/4 Lge Flg Gr 5 Zinc
21	532 17 18-52	Bolt Shoulder 5/16-18 Unc-2A
22	873 80 05-00	Nut Hex Lock w/Ins 5/16-18
23	871 11 08-14	Bolt Hex Black
24	819 17 19-12	Washer 17/32 X 1-3/16 X 12 Ga.
25	532 12 70-18	Bolt Shoulder 5/16-18 X 62
26	810 04 08-00	Washer Lock Hvy Hlcl Spr 1/2

NOTE: All component dimensions given in U.S. inches.
1 inch = 25.4 mm

REPAIR PARTS

TRACTOR- -MODEL NO. REN1192RB (REN1192RBA), PRODUCT NO. 964 77 85-00
DECALS

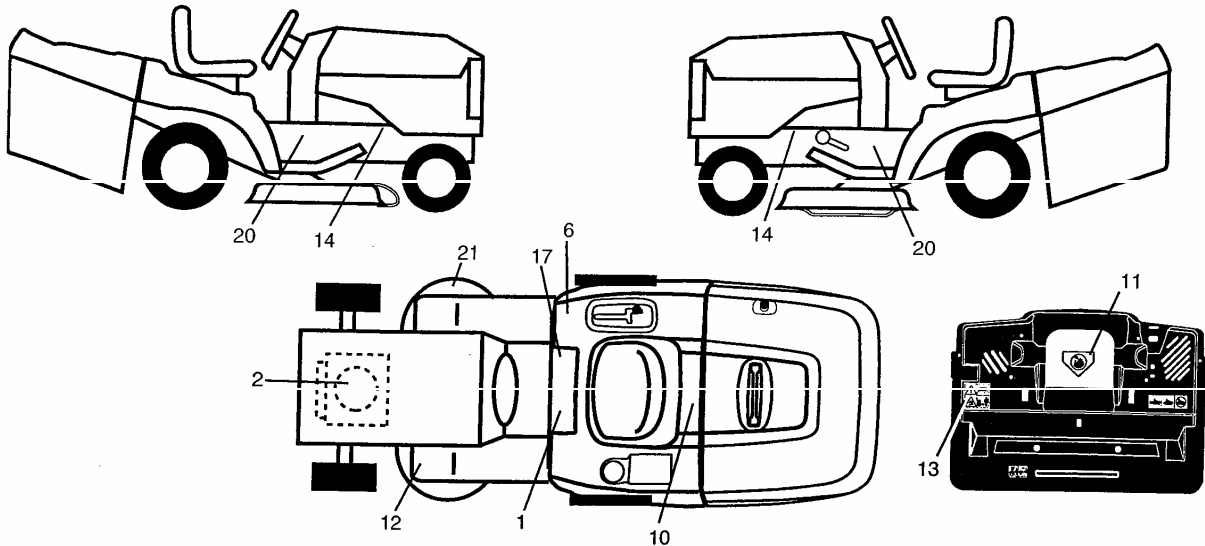

KEY NO.	PART NO.	DESCRIPTION
1	532 14 54-98	Decal Read Owner's Manual Sym
2	532 18 47-64	Decal Hp Engine
6	532 18 04-32	Decal Fender 100 OB/CE
10	532 14 50-05	Decal Bat Dan/Poi P/L Sym Wprn
11	532 18 21-66	Decal Mower Cut Finger Symbol
12	532 15 97-37	Decal Brake/Clutch Symbol Lt
13	532 18 04-35	Decal Warn Back Plate CRD
14	532 15 97-36	Decal Chassis Hot Muffler
17	532 14 08-37	Decal Saddle Brake Parking

KEY NO.	PART NO.	DESCRIPTION
20	532 18 11-48	Decal Chassis
21	532 16 62-86	Decal Hex Belt Sch 92 CRD
—	532 18 10-90	Pad Footrest RH
—	532 13 83-11	Decal Lift Handle
—	532 18 26-21	Decal Bagger Frame
—	532 18 10-91	Pad Footrest LH
—	532 18 52 30	Manual Operator's (Euro)
—	532 18 51-87	Manual Parts

WHEELS & TIRES

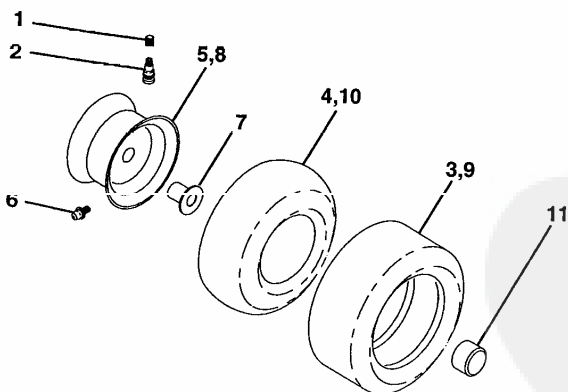

KEY NO.	PART NO.	DESCRIPTION
1	532 05 91-92	Cap Valve Tire
2	532 06 51-39	Stem Valve
3	532 10 62-22	Tire F Ts 15 X 6 0 - 6 Service
4	532 05 99-04	Tube Inner Front #35060
5	532 18 33-37	Rim Asm 6"front Service
6	532 12 49-57	Fitting Grease
7	532 12 49-59	Bearing Flange
8	532 18 33-38	Rim Asm 8"rear Service
9	532 12 46-35	Tire R Ts 20 x 8-8 Service
10	532 12 49-26	Tube Rear 9 5 X 8 Service
11	532 17 50-39	Cap Axle Blk 1 50 X 1 00
--	532 14 43-34	Sealant, Tire (10 oz. tube)

NOTE: All component dimensions given in U.S. inches
1 inch = 25.4 mm

REPAIR PARTS

TRACTOR- -MODEL NO. REN1192RB (REN1192RBA), PRODUCT NO. 964 77 85-00
ENGINE

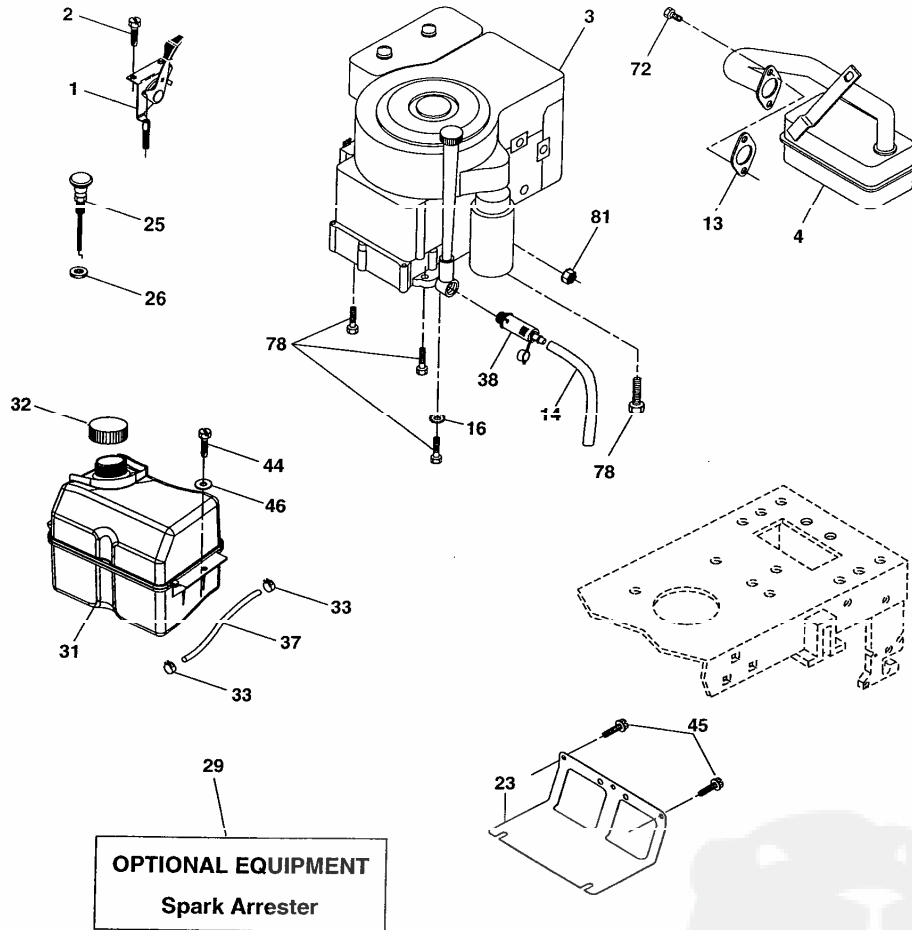

OPTIONAL EQUIPMENT
Spark Arrester

KEY NO.	PART NO.	DESCRIPTION	KEY NO.	PART NO.	DESCRIPTION
1	532 17 05-51	Control Throt	32	532 14 05-27	Cap Asm Fule Top Vent N/Lany
2	817 72 04-08	Screw Hex Thd Cut 1/4-20x1/2	33	532 12 34-87	Clamp Hose Blk
3	-----	Engine B&S Model 21A807 (Order Parts from Engine Manufacturer)	37	532 13 70-40	Line Fuel 20"
4	532 17 97-58	Muffler Exhaust B&S Lt	38	532 18 16-54	Plug Drain Oil Easy
13	532 16 52-91	Gasket 1 313 Id Tin Plated	44	817 67 04-12	Screw Hexwsh Thdrol 3/8-16 x 3/4
14	532 14 84-56	Tube Drain Oil Easy	45	817 00 06-12	Screw 3/8-16 x 3/4
16	811 05 06-00	Washer Lock Ext Tooth 3/8	46	819 09 14-16	Washer 9/32 X 7/8 X 16ga
23	532 16 98-37	Shield Browning/Debris Guard	72	532 18 39-06	Screw Socket Head 5/16-18 x 1
25	532 18 09-45	Control Choke	78	817 06 06-20	Screw 3/8-16x1-1/4
26	873 92 06-00	Nut Keps 3/8-24 Unf	81	873 51 04-00	Nut Keps Hex 1/4-20 UNC
29	532 13 71 90	Arrester Spark			
31	532 18 55-34	Tank Fuel 2.00 Fr			

NOTE: All component dimensions given in U.S. inches
1 inch = 25.4 mm

REPAIR PARTS

TRACTOR- -MODEL NO. REN1192RB (REN1192RBA), PRODUCT NO. 964 77 85-00
MOWER LIFT

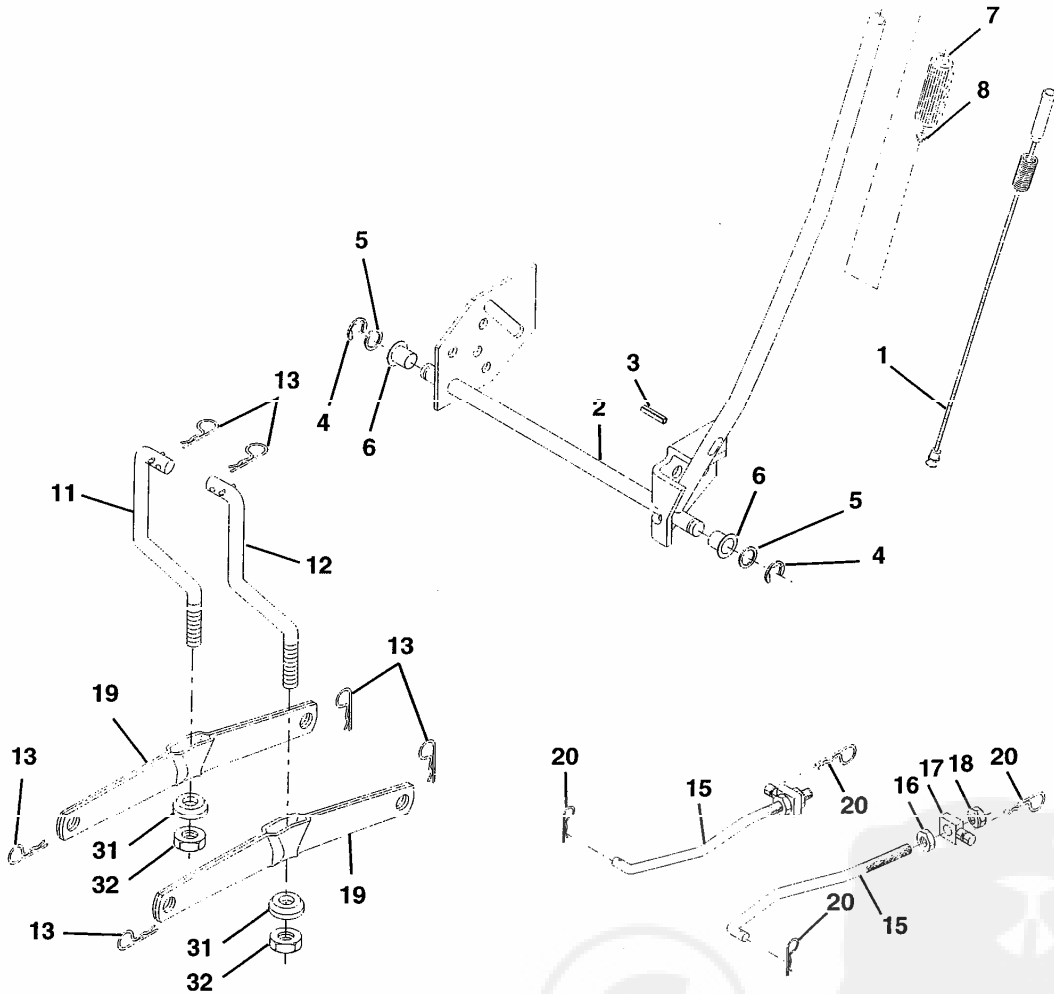

KEY NO.	PART NO.	DESCRIPTION
1	532 15 94-61	Washer Asm Inner Spring W/ Plunger
2	532 15 94-76	Shaft Asm. Lift
3	532 17 89-81	Pin Groove
4	812 00 00-02	E Ring #5133-62
5	819 21 16-21	Washer 21/32 x 1 x 21 Ga.
6	532 12 01-83	Bearing Nylon
7	532 10 94-13	Grip Handle Bicycle
8	532 12 45-26	Button Plunger Black
11	532 16 58-29	Link Asm Lift L.H.
12	532 16 58-31	Link Asm Lift R.H.
13	532 12 46-70	Retainer Spring

KEY NO.	PART NO.	DESCRIPTION
15	532 17 32-88	Link Front
16	873 35 08-00	Nut Jam Hex 1/2-13 Unc
17	532 17 56-89	Trunnion Blk Zinc
18	873 80 08-00	Nut Lock w/Wsh 1/2-13 Unc
19	532 13 98-68	Arm Suspension Mower
20	532 16 35-52	Retainer Spring
31	532 16 98-65	Bearing, Pvt. Lift.
32	873 54 06-00	Nut Crownlock 3/8-24

NOTE: All component dimensions given in U.S. inches
1 inch = 25.4 mm

REPAIR PARTS

TRACTOR- -MODEL NO. REN1192RB (REN1192RBA), PRODUCT NO. 964 77 85-00
MOWER

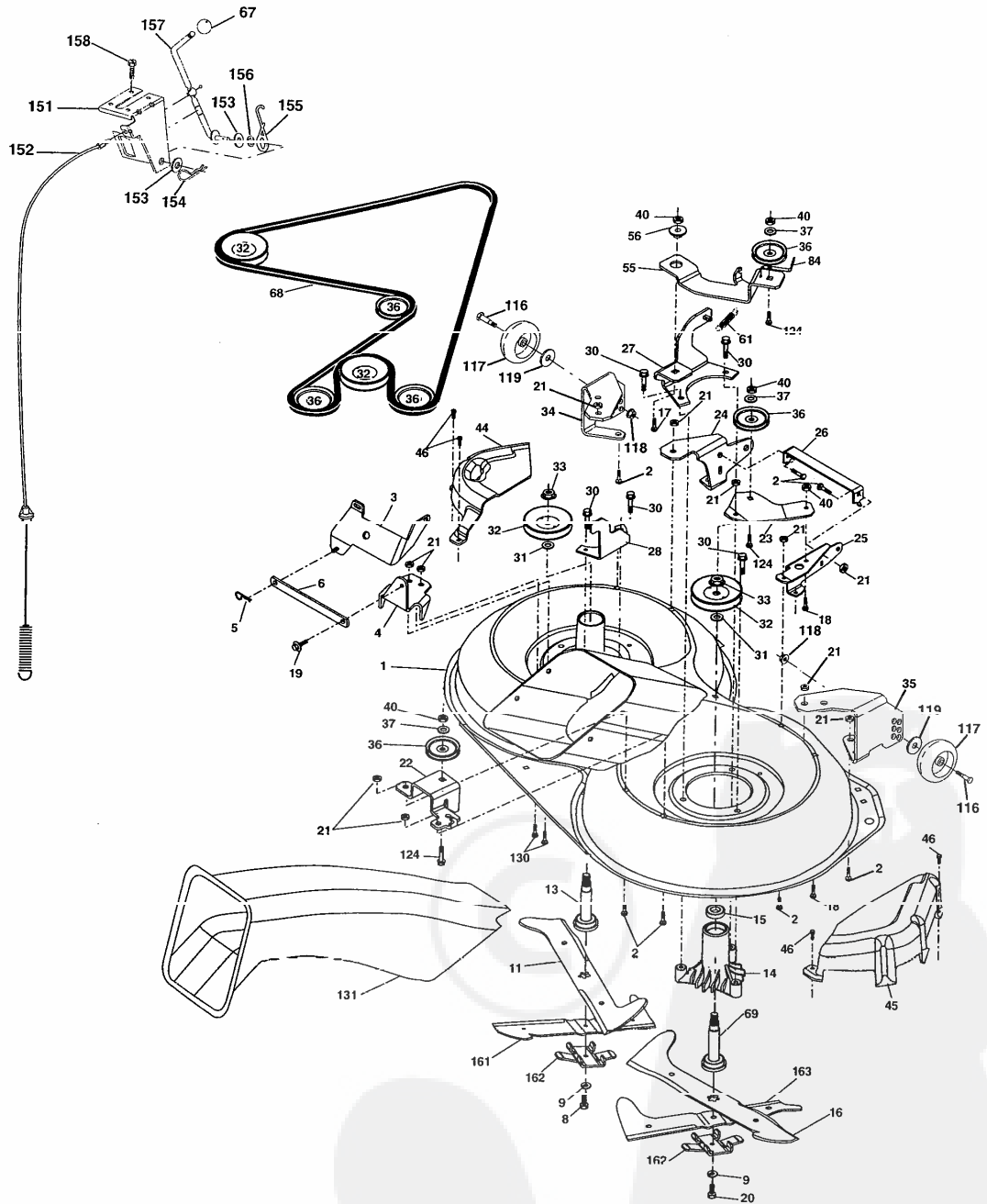

REPAIR PARTS

TRACTOR- -MODEL NO. REN1192RB (REN1192RBA), PRODUCT NO. 964 77 85-00
MOWER

KEY NO.	PART NO.	DESCRIPTION	KEY NO.	PART NO.	DESCRIPTION
1	532 16 55-52	Housing Asm. Mower	44	532 17 55-38	Cover Mandrel Lh
2	872 14 05-06	Bolt Rdhd Sqnk 5/16-18 Unc x 3/4	45	532 17 55-39	Cover Mandrel Rh
3	532 16 55-69	Bracket Asm. S-Bar Chass	46	532 13 77-29	Screw Thd Roll 1/4-20 x 5/8
4	532 16 55-58	Bracket Bar Sway Deck	55	532 16 54-45	Arm Idler
5	532 12 46-70	Retainer Spring	56	532 16 57-23	Spacer Retainer PM Mower
6	532 16 55-57	Bar Sway	61	532 16 59-45	Spring Tension Belt
8	532 18 17-12	Bolt 3/8-24 x 1.25 Gr8 Patched	67	532 10 69-32	Knob Rd 3/8-16 Plstc Thds Blk
9	810 03 06-00	Washer Lock Hvy 3/8 Unplated	68	532 18 02-17	Hex-Belt 92 Mower
11	532 17 00-37	Blade 3-1 Lh	69	532 16 54-82	Shaft Asm W/Lwr Brg Rh Thd CRD
13	532 13 76-45	Shaft Asm. W/Lower Bearing	84	532 15 60-85	Keeper Belt Idler
14	532 12 87-74	Housing Mandrel Vented (Machd)	116	532 18 42-19	Bolt Shoulder
15	532 11 04-85	Bearing Ball Mandrel	117	532 13 39-57	Wheel Gage Donut Wide
16	532 17 00-38	Blade 3-1 Rh	118	873 93 06-00	Nut Centerlock 3/8-16 Unc
17	872 14 06-10	Bolt Carriage 3/8-16 x 1-1/4	119	819 12 14-14	Washer 3/8 x 7/8 x 14 Ga.
18	872 11 06-06	Bolt Rdhd Sqnk 3/8-16 x 3/4	124	872 11 06-12	Bolt Carr Sh 3/8-16 x 1-1/2 Gr5
19	532 13 28-27	Bolt Shoulder 5/16-18 Thd Form	130	872 11 05-06	Bolt Rdhdsqnk 5/16-18 Unc x 3/4
20	532 18 17-13	Bolt 3/8-24 x 1.25 Gr8 Ptch Lhthd	131	532 16 56-61	Chute Bagger CRD
21	873 68 05-00	Nut Crown Lock 5/16-18	151	532 16 56-70	Bracket Clutch Cable
22	532 16 52-43	Bracket Idler Sprt RR	152	532 17 60-74	Cable Clutch CRD Service
23	532 16 54-46	Bracket Idler Sprt RF	153	532 16 96-74	Washer Flat 3/8" Type B
24	532 16 52-42	Bracket Suspension LF	154	532 16 96-75	Spring Retainer
25	532 16 52-44	Bracket Suspension RF	155	532 16 96-71	Spring Retainer Lvr Cltch Cab
26	532 16 52-37	Brace Support Susp Frt CRD	156	532 16 96-72	Spacer Clutch Cable
27	532 16 55-68	Bracket Asm. Susp RR	157	532 16 96-69	Rod Clutch Cable 3/8"
28	532 16 55-67	Bracket Asm. Susp LR	158	817 72 04-08	Screw Hex Thdcut 1/4-20 x 5/8
30	532 17 39-84	Screw Thd Rolling Washer Head	161	532 18 04-18	Blade Cross Lh 92
31	532 12 99-63	Washer Spacer Mower Vented	162	532 18 00-10	Adapter Blade Cross
32	532 15 35-31	Mandrel Pulleys 36 & 46	163	532 18 04-19	Blade Cross Rh 92
33	532 17 83-42	Nut Flg Top Lock	--	532 18 18-57	Mandrel Asm Service
34	532 16 52-39	Bracket Gauge Wheel Lf	--	532 18 18-58	Mandrel Asm CRD Lh Threads SVC
35	532 16 52-38	Bracket Gauge Wheel Rf	--	532 18 17-65	Replacement Mower Complete
36	532 14 67-63	Pulley Idler V-Groove Dim 4.25			
37	819 13 13-16	Washer 11/32 x 13/16 x 16 Ga			
40	873 68 06-00	Nut Crownlock 3/8-16 Unc			

NOTE: All component dimensions given in U.S. inches
1 inch = 25.4 mm

REPAIR PARTS

TRACTOR- -MODEL NO. REN1192RB (REN1192RBA), PRODUCT NO. 964 77 85-00
BAGGER

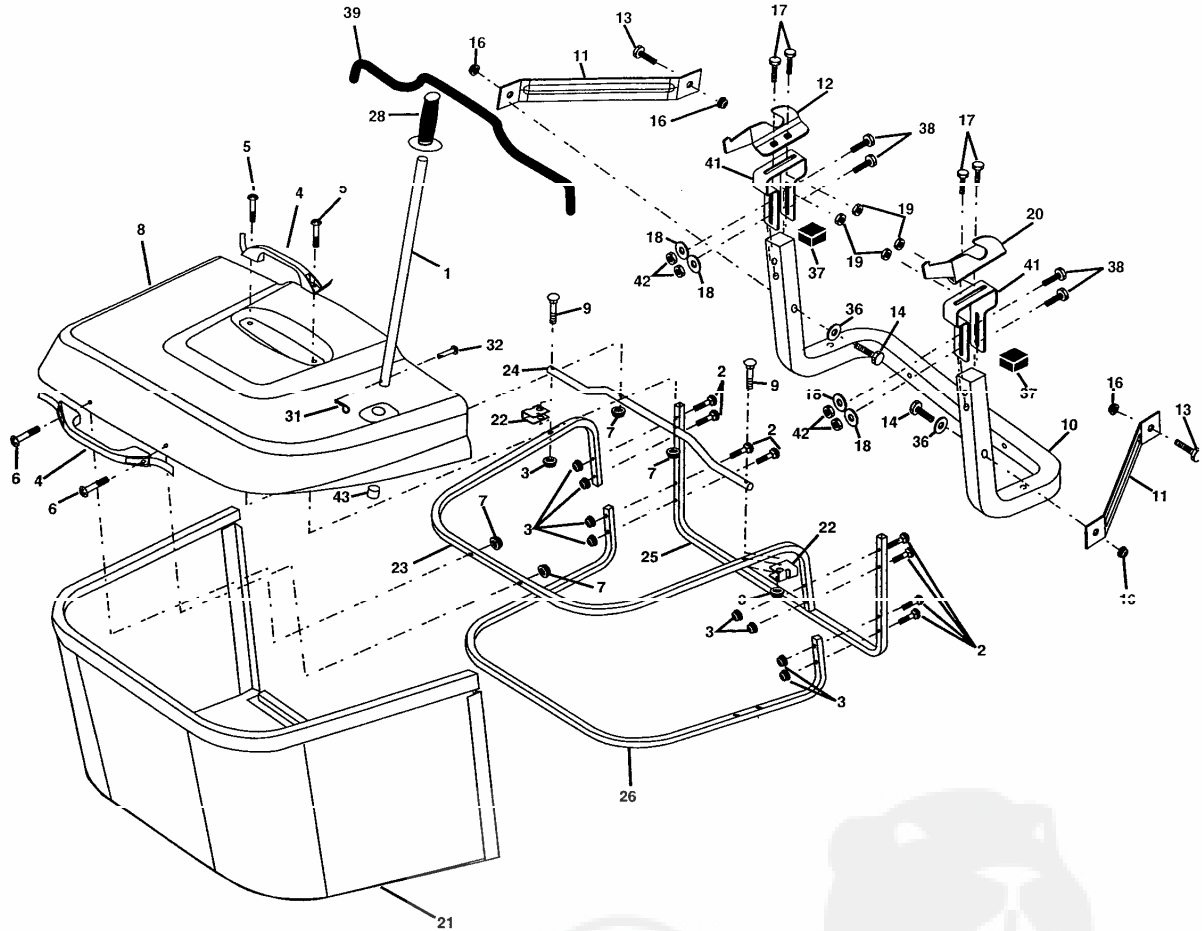

KEY NO.	PART NO.	DESCRIPTION
1	532 16 52-49	Tube Handle Bagger CRD
2	872 14 04-16	Bolt Carriage 1/4-20 X 2.0 Gr.5
3	532 12 39-76	Nut Lock 1/4 Lge Flg Gr. 5 Zinc
4	532 16 99-16	Handle Bagger w/Lvrs Gr. 5 Zinc
5	874 98 10-24	Screw Pan Head #10-24 X 1.50 Blk
6	874 98 10-32	Screw Pan Hd
7	873 40 10-00	Nut Wiz Lock Hex Serr/Hd #10-24
8	532 18 13-54	Cover Bagger Steel
9	872 14 04-18	Bolt Carriage 1/4-20 x 2.25d x Gr.5
10	532 18 12-82	Tube Support Bagger CRD
11	532 16 57-19	Bracket Support Upper Bag CRD
12	532 16 96-85	Bracket Horiz. Adj Bagger
13	872 11 06-06	Bolt Rdhd Sht Sqnk 3/8-16 X 3/4
14	874 52 06-36	Bolt Hex 3/8-16 X 2-1/4 Gr. 5
16	873 90 06-00	Nut Lock Flg 3/8-16 Unc
17	872 14 05-06	Bolt Rdhd Sht Sqnk 5/16-18Unc X 3/4
18	819 11 12-16	Washer 11/32 x 3/4 x 16 Ga.
19	873 90 05-00	Nut Lock Hex Flange 5/16-18

KEY NO.	PART NO.	DESCRIPTION
20	532 16 96-84	Bracket Horiz Adj Bagger
21	532 18 08-80	Bag Asm CRD
22	532 16 57-81	Bracket Side Bagger CRD
23	532 16 57-82	Tube Upper Bagger CRD
24	532 16 57-83	Tube Pivot Bagger CRD
25	532 18 01-24	Tube Front Bagger CRD
26	532 16 57-85	Tube Lower Bagger CRD
28	532 16 57-87	Grip Handle Black
31	532 16 94-84	Retainer Clip
32	532 12 68-75	Rivet Rd Hd Drilled 3/8 Dia
36	819 13 20-16	Washer 13/32 x 1-1/4 x 16 Ga.
37	532 17 54-01	Plug Support Bagger CRD
38	872 01 05-20	Bolt 5/16-18 x 2-1/2
39	532 18 09-85	Seal Trim 37"
41	532 16 96-83	Bracket Vert Adj Bagger CRD
42	873 80 05-00	Nut Lock Hx w/Ins 5/16-18 Unc
43	532 17 40-83	Plug Tubing End

NOTE: All component dimensions given in U.S. inches
1 inch = 25.4 mm



Issued January 1980
Revised January 1991

SERVICE POLICY WARRANTY

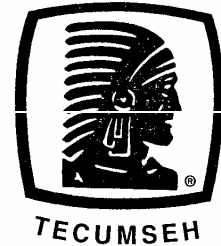

LIMITED WARRANTIES FOR NEW PEERLESS GEAR POWER TRAIN COMPONENTS

A. Products Warranted

Peerless Gear and Machine Division of Tecumseh Products Company ("Tecumseh"), subject to the limitations contained below, will, at its option, repair or replace, without charge for parts or labor only, any part of a new Power Train Component (which as used herein means and includes the transaxle, gear box, transmission, differential and right angle drives, and any part of the Power Train Component), EXCEPT any new Power Train Component incorporated in equipment used for commercial or rental purposes, which is found upon examination by any Tecumseh Authorized Service Outlet or by Tecumseh's factory in Grafton, Wisconsin, to be DEFECTIVE IN MATERIAL AND/OR WORKMANSHIP if received by Tecumseh or a Tecumseh Authorized Service Outlet for such examination within TWO YEARS from the date of sale to the original consumer purchaser of Peerless Series 820, 900, 910, 915, 920, 930 transaxles and Series 1100 angle drive and ONE YEAR for all other Peerless products. New Power Train Components incorporated in equipment used for commercial purposes are warranted in the same manner and to the same extent EXCEPT such Power Train Components are warranted for NINETY (90) DAYS ONLY, and must be received by Tecumseh or by a Tecumseh Authorized Service Outlet for such examination within 90 days from the date of sale to the original purchaser. New Power Train Components incorporated in equipment used for rental purposes are warranted in the same manner and to the same extent EXCEPT such Power Train Components are warranted for THIRTY (30) DAYS ONLY, and must be received by Tecumseh or a Tecumseh Authorized Service Outlet within 30 days from the date of sale to the original purchaser.

B. Products And Items Not Warranted

1. Alterations or Modifications of Power Train Components.
2. Accidents, Normal Maintenance, Failure to follow the Original Equipment Manufacturer's Manual.

This warranty covers only parts of new Power Train Components which are found upon examination to be defective in material or workmanship as delivered to the original purchaser. This warranty does not cover defects caused by depreciation or damage caused by normal wear, accidents, improper maintenance, improper use or abuse of the product, failure to follow the instructions contained in an Instruction Manual for the operation of the Power Train Component and parts. The cost of normal maintenance and replacement of service items which are not defective shall be paid for by the original purchaser.

C. Securing Warranty Service

Warranty service can be arranged for by contacting either a Tecumseh Authorized Service Outlet (any Tecumseh Registered Service Dealer, Tecumseh Authorized Service Distributor, or Tecumseh Central Warehouse Distributor) or by contacting Tecumseh, c/o Service Manager, Engine and Transmission Group Service Division, 900 North Street, Grafton, Wisconsin 53024. Warranty service can only be performed by a Tecumseh Authorized Service Outlet or by Tecumseh at its factory in Grafton, Wisconsin. At the time of requesting warranty service, evidence must be presented of the date of sale to the original purchaser. The purchaser shall pay any charges for making service calls and/or for transporting the product to and from the place where the inspection and/or warranty work is performed. The purchaser shall be responsible for any damage or loss incurred in connection with the transportation of Power Train Components and/or part(s) of the Power Train Components submitted for inspection and/or warranty work.

D. Limitation of Damages and Implied Warranties

The foregoing EXPRESSED WARRANTY IS IN LIEU OF ALL OTHER EXPRESS WARRANTIES. Neither Tecumseh nor any of its affiliates makes any warranties, representations or promises, written or oral, as to the quality of the Power Train Component or any of its parts, other than as set forth herein.

ANY IMPLIED WARRANTY OF MERCHANTABILITY OR FITNESS FOR A PARTICULAR PURPOSE, TO THE EXTENT THAT EITHER MAY APPLY TO ANY PART(S) OF POWER TRAIN COMPONENTS, SHALL BE LIMITED IN DURATION TO THE PERIODS OF THE EXPRESSED WARRANTIES DEFINED IN PARAGRAPH A HEREOF. IN NO EVENT WILL TECUMSEH BE LIABLE FOR ANY INCIDENTAL, CONSEQUENTIAL OR SPECIAL DAMAGES AND/OR EXPENSES. Some states do not allow limitations on how long an implied warranty lasts or the exclusion or limitation of incidental or consequential damages, so the above limitation(s) or exclusion(s) may not apply to you. This warranty gives you specific legal rights and you may also have other legal rights which vary from state to state.

E. No Dealer Warranty

Tecumseh neither assumes nor authorizes any other person, natural or corporate, to assume for Tecumseh any other obligations or liabilities in connection with or with respect to any part(s) of a Power Train Component. The seller or dealer of part(s) of a Power Train Component has no authority, whatsoever, to make any representations or promises on behalf of Tecumseh or to modify the terms or limitations of Tecumseh's warranty in any way.