

**REPAIR PARTS MANUAL**  
**MODEL NO. WZ125H42B**  
**Lawn Tractor**

---

**WIZARD**

# HOW TO USE THIS MANUAL

This manual is designed to provide the customer with a means to identify the parts on his/her tractor when ordering repair parts. The illustrations may or may not represent the actual assemblies; therefore, it is not recommended to use this manual as a guide to assemble or disassemble the tractor. Some hardware and parts are drawn larger in order to more readily identify them.

Each tractor has its own model number.

The model number for your tractor can be found on the fender under the seat.

When ordering parts, always give the following information:

- Product - "Lawn Tractor"
- Model Number - "WZ125H42B"
- Part Number
- Part Description

## TABLE OF CONTENTS

SCHEMATIC.....	3
ELECTRICAL.....	4-5
CHASSIS AND ENCLOSURES.....	6-7
DRIVE.....	8-9
STEERING WHEEL.....	10-11
SEAT.....	12
DECALS.....	13
ENGINE.....	14-15
MOWER LIFT.....	16-17
MOWER DECK.....	18-19
WARRANTY.....	20

# TRACTOR- -MODEL NO. WZ125H42B, PRODUCT NO. 954 56 84-27

## SCHEMATIC

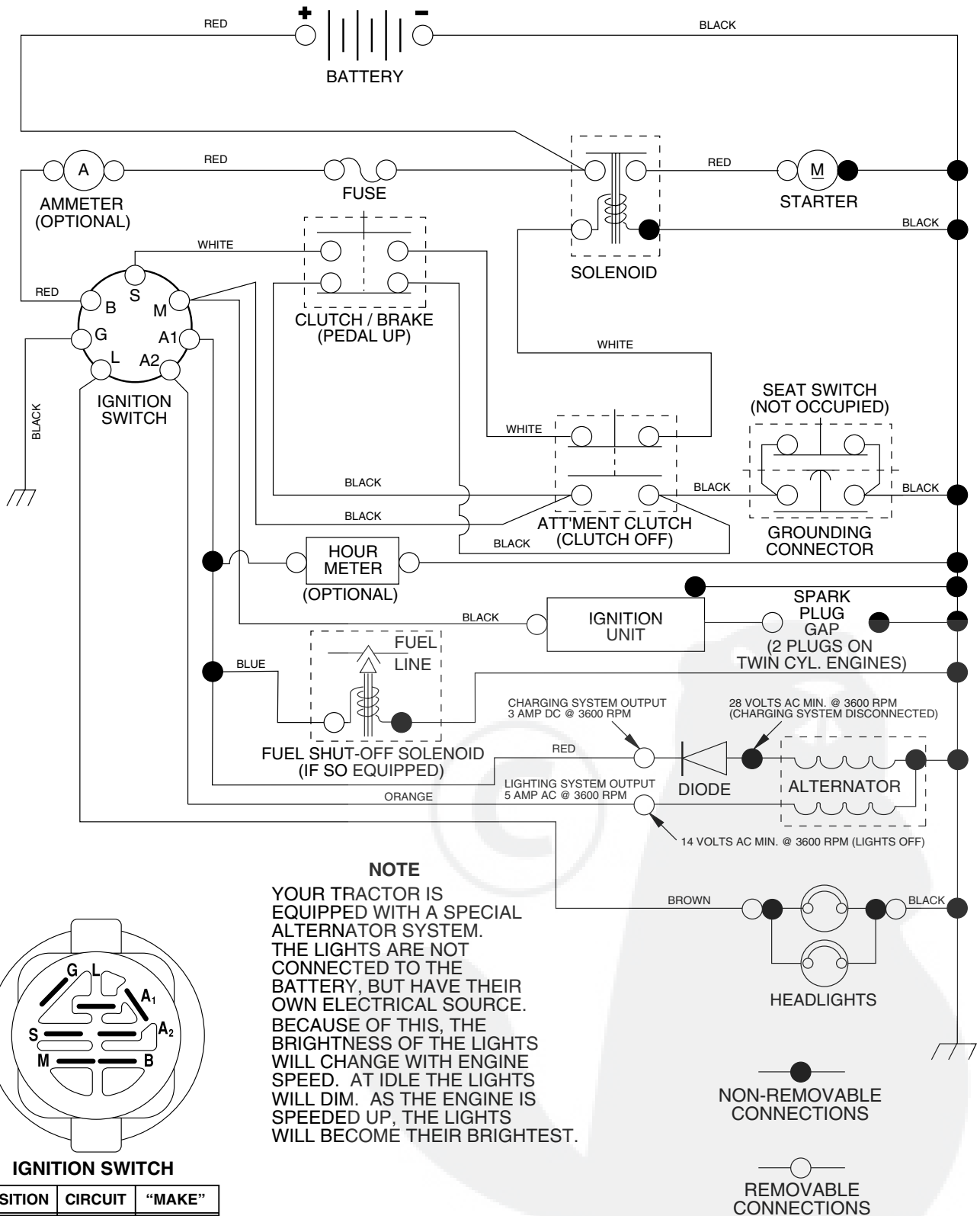

# REPAIR PARTS

TRACTOR- -MODEL NO. WZ125H42B, PRODUCT NO. 954 56 84-27  
ELECTRICAL

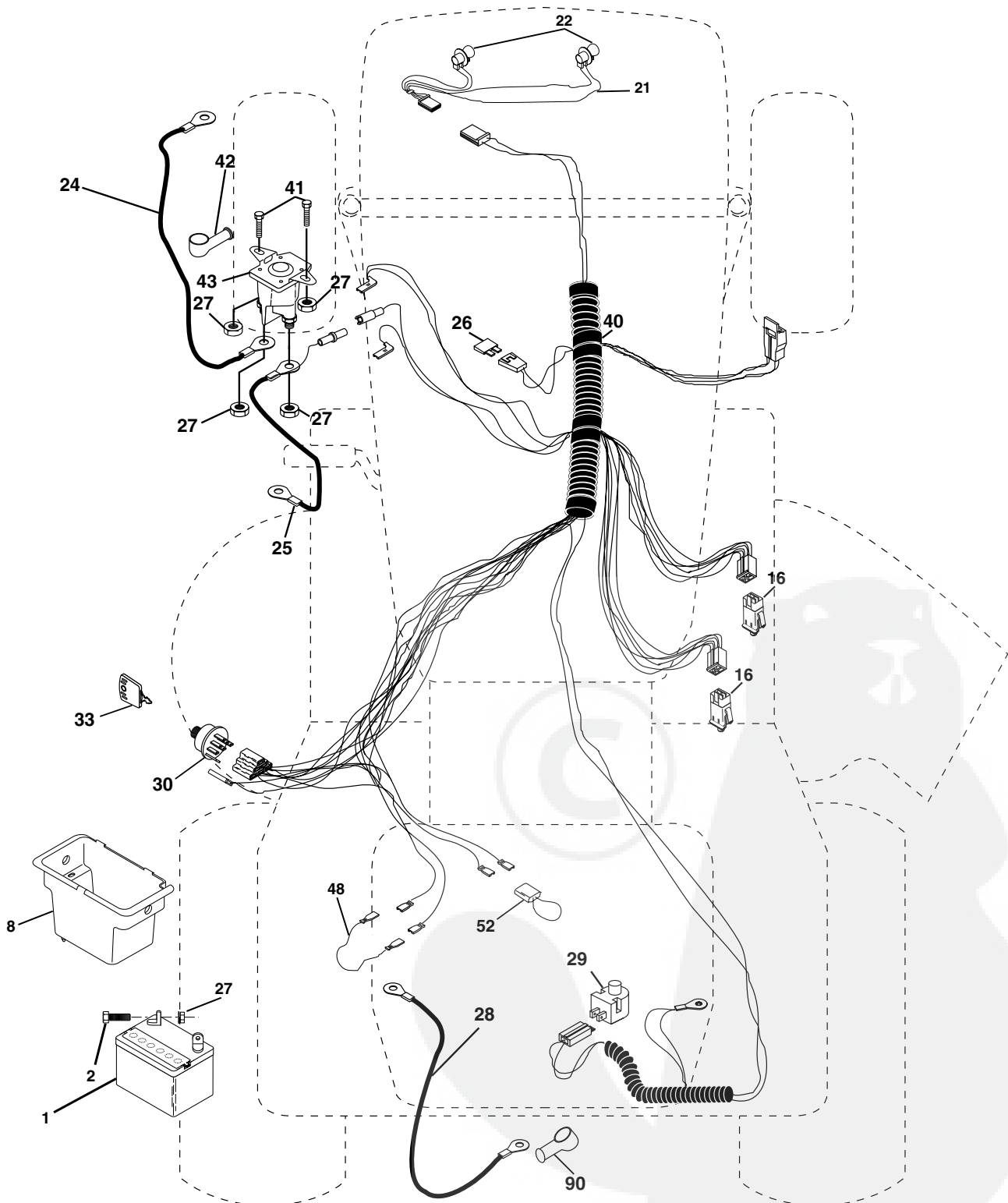

# REPAIR PARTS

TRACTOR- -MODEL NO. WZ125H42B, PRODUCT NO. 954 56 84-27  
ELECTRICAL

KEY NO.	PART NO.	DESCRIPTION
1	532 16 34-65	Battery 12 Volt 28 AMP
2	874 76 04-12	Bolt Hex Hd 1/4-20unc X 3/4
8	532 17 66-89	Box Battery Fender
16	532 17 61-38	Switch Interlock
21	532 17 56-85	Harness Asm Light W/4152j
22	532 00 41-52	Bulb Light #1156
24	532 12 47-80	Cable Battery 6 Ga 11" Red
25	532 14 61-47	Cable Battery 6 Ga Red w/16 wir
26	532 17 51-58	Fuse 20 AMP
27	873 51 04-00	Nut Keps Hex 1/4-20 Unc
28	532 12 47-73	Cable Ground 6 Ga 12" black
29	532 12 13-05	Switch Plunger Nc Gray
30	532 17 55-66	Switch Ign
33	532 14 04-01	Key
40	532 17 97-20	Harness Ing Cable Clutch
41	871 11 04-08	Bolt Blk Fin Hex 1/4 - 20 x 1/2
42	532 13 15-63	Cover Terminal Red
43	532 17 88-61	Solenoid
48	532 14 08-44	Adapter Ammeter Rectangular
52	532 14 19-40	Protection Wire Loop
90	532 18 04-49	Cover Terminal Battery

**NOTE:** All component dimensions given in U.S. inches.  
1 inch = 25.4 mm.



# REPAIR PARTS

TRACTOR- -MODEL NO. WZ125H42B, PRODUCT NO. 954 56 84-27  
CHASSIS AND ENCLOSURES

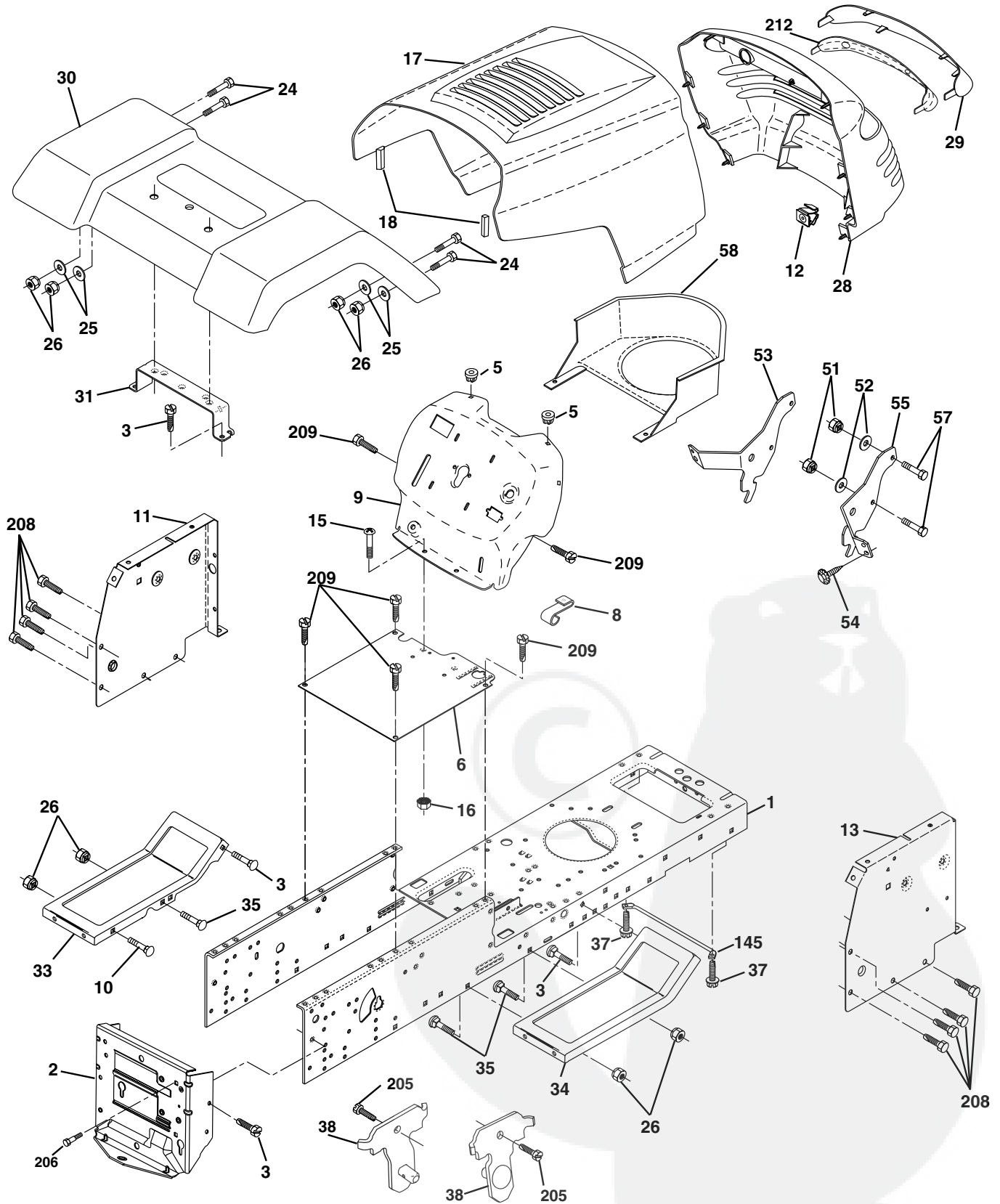

# REPAIR PARTS

## TRACTOR- -MODEL NO. WZ125H42B, PRODUCT NO. 954 56 84-27 CHASSIS AND ENCLOSURES

KEY NO.	PART NO.	DESCRIPTION
1	532 16 98-31	Chassis
2	532 16 90-61	Drawbar
3	817 06 06-12	Screw 3/8-16 x .75
5	532 15 52-72	Bumper Hood Dash
6	532 15 59-23	Saddle Flat
8	532 15 51-38	Clip Retainer Slide-On
9	532 17 22-43	Dash
10	872 14 06-08	Bolt Rdhd Sqnk 3/8-16unc X 1
11	532 15 59-27	Panel Dash LH
12	532 14 56-60	Clip Tinnerman Grille P/L
13	532 17 30-25	Panel Dash RH
15	874 18 05-12	Screw Mach THD 5/16-18 x 3/4
16	873 51 05-00	Nut Keps 5/16-18
17	532 15 93-55	Hood
18	532 12 69-38	Bumper Hood
20	532 15 64-37	Plate Mtg Battery/Fuel
23	532 12 40-28	Bushing Snap Nyl Blk Fuel Line
24	874 78 06-16	Bolt Fin Hex 3/8-16unc X 1 Gr. 5
25	819 13 13-12	Washer 13/32 X 13/16 X 12 Ga.
26	873 80 06-00	Nut Lock Hex w/Ins 3/8-16 Unc
28	532 17 91-01	Grille / Lens
29	532 16 81-54	Lens Grille Private Label
30	532 17 45-11	Fender
31	532 13 66-19	Bracket Fender Repl 109873x
33	532 18 11-93	Footrest Pnt LH
34	532 18 11-94	Footrest Pnt RH
35	872 11 06-06	Bolt Rdhd Sht Sqnk 3/8-16 X3/4
37	817 49 05-08	Screw Thdrol 5/16-18 x 1/2 Tyt
38	532 16 98-34	Bracket Asm Pivot Mower Rear
51	873 80 04-00	Nut Lock w/Insert 1/4-20
52	819 09 14-16	Washer 9/32 x 7/8 x 16 Ga.
53	532 14 46-97	Bracket Grille LH
54	532 16 14-64	Screw Hex Wshd 8-18 x 7/8
55	532 14 46-96	Bracket Grille RH
57	874 78 04-12	Bolt Hex 1/4-20 x 3/4
58	532 14 05-47	Air Duct Private Label
145	532 15 65-24	Rod Pivot Chassis/Hood
206	532 17 01-65	Bolt Shoulder 5/16-18
207	817 67 05-08	Screw Thdrol 5/16-18 x 1/2
208	817 67 06-08	Screw Thdrol 3/8-16 x 1/2
209	817 00 06-12	Screw Hexwsh Thdr 3/8-16 x 3/4
212	532 15 62-29	Insert Lens Reflective
--	532 00 54-79	Plug Button Blk 359 Dia Choke

**NOTE:** All component dimensions given in U.S. inches.  
1 inch = 25.4 mm.

# REPAIR PARTS

TRACTOR- -MODEL NO. WZ125H42B, PRODUCT NO. 954 56 84-27

DRIVE

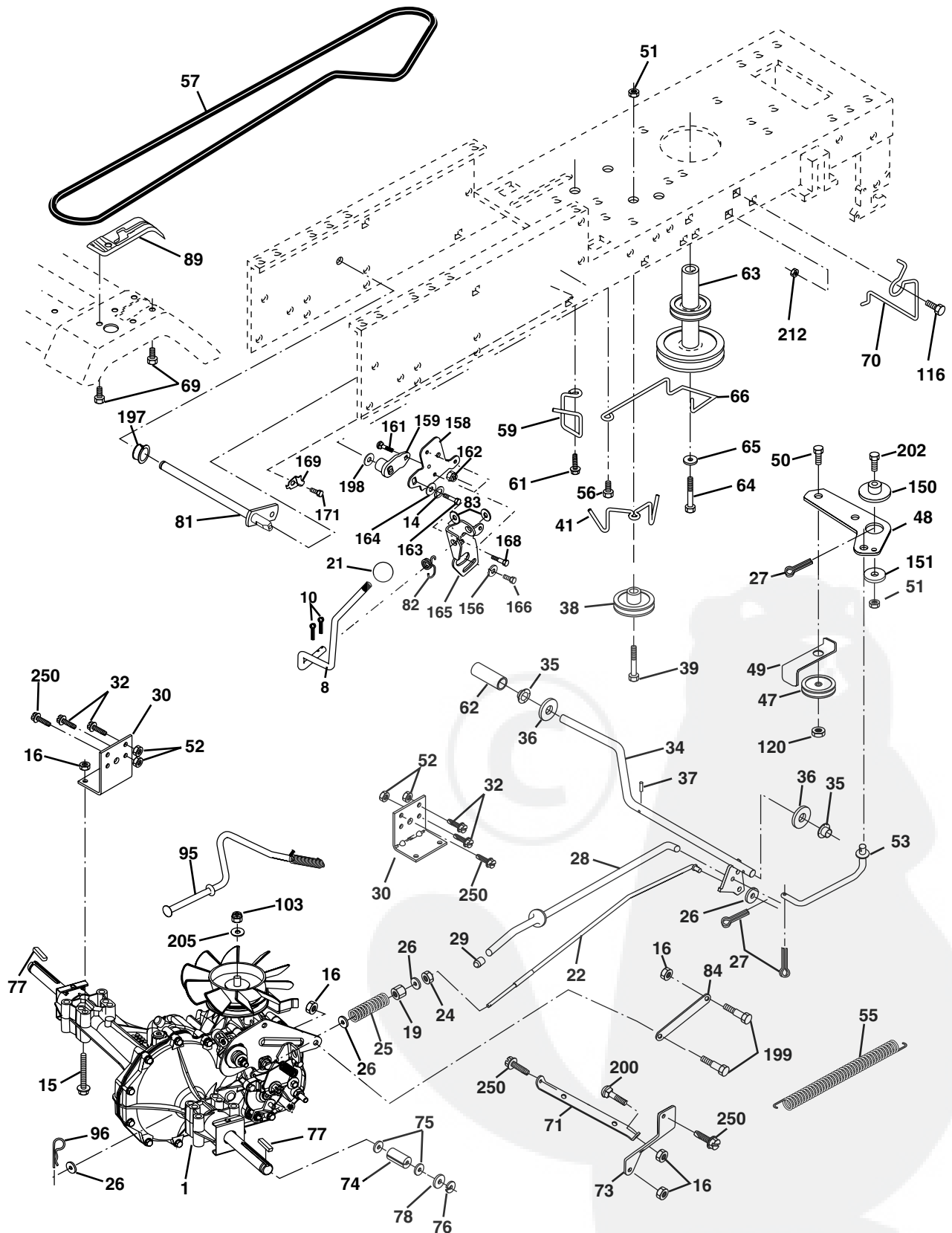



# REPAIR PARTS

TRACTOR- -MODEL NO. WZ125H42B, PRODUCT NO. 954 56 84-27

## DRIVE

KEY NO.	PART NO.	DESCRIPTION	KEY NO.	PART NO.	DESCRIPTION
1	-----	Transaxle Hydro Gr 322-0510	69	532 14 24-32	Screw Hex Wsh Hi-Lo 1/4-1/2 Unc
8	532 16 56-19	Rod Shift Fender Adjust	70	532 18 02-18	Guide Belt Mwr.
10	876 02 04-16	Pin Cotter 1/8 x 1 CAD	71	532 16 91-83	Strap Torque Lh Hydro
14	810 04 04-00	Washer Lock Hvy Helical	73	532 16 91-82	Strap Torque Rh Hydro
15	874 49 05-44	Bolt Hex FLGHD 5/16-18 x Gr 5	74	532 13 70-57	Spacer, Split
16	873 80 05-00	Nut Lock Hex W/Ins. 5/16-18 Unc	75	532 12 17-49	Washer 25/32 x 1-1/4 x 16 Gauge
19	873 80 06-00	Nut Lock Hex W/Wsh 3/8-16 Unc	76	812 00 00-01	E-Ring
21	532 10 69-33	Knob, Round 1/2-13	77	532 12 35-83	Key, Square
22	532 16 94-98	Rod, Brake Hydro	78	532 12 17-48	Washer 25/32 x 1-5/8 x 16 Gauge
24	873 35 06-00	Nut, Hex Jam 3/8-16 Unc	81	532 16 55-96	Shaft Asm Cross Tapered
25	532 10 68-88	Spring, Brake Rod	82	532 12 37-82	Spring Torsion
26	819 13 13-16	Washer	83	819 17 12-16	Washer 17/32 x 3/4 x 16 Ga.
27	876 02 04-12	Pin Cotter 1/8 x 3/4 CAD.	84	532 16 98-43	Link Transaxle
28	532 17 57-65	Rod, Parking Brake	89	532 17 30-29	Console, Shift
29	532 07 16-73	Cap, Parking Brake	95	532 17 02-01	Control Bypass Hydro 20" Tires
30	532 17 49-73	Bracket, Transaxle	96	532 12 47-88	Retainer Spring 1" Zinc/Cad
32	874 76 05-12	Bolt Hex Hd 5/16-18 Unc x 3/4	103	873 94 08-00	Nut Hex Jam Toplock 1/2-20
34	532 17 55-78	Shaft, Foot Pedal	116	872 14 06-08	Bolt Rdhd Sqneck 3/8-16 x 1
35	532 12 01-83	Bearing, Nylon	120	873 90 06-00	Nut Lock Flg 3/8-16
36	819 21 16-16	Washer	150	532 17 54-56	Spacer Retainer
37	532 12 49-63	Pin, Roll	151	819 13 32-10	Washer 13/32 x 2 x 10 Ga.
38	532 17 91-14	Pulley, Idler	156	532 16 60-02	Washer Srrted 5/16ID x 1.125
39	874 76 06-48	Bolt, Fin Hex 3/8-16 x 3	158	532 16 55-89	Bracket Shift Mount
41	532 17 55-56	Keeper, Belt Idler	159	532 16 54-94	Hub Tapered Flange Shift Lt
47	532 12 77-83	Pulley, Idler, V-Groove	161	872 14 04-06	Bolt Rdhd Sqnk 1/4-20 x 3/4 Gr 5
48	532 15 44-07	Bellcrank, Clutch	162	873 68 04-00	Nut Crownlock 1/4-20 Unc
49	532 12 32-05	Retainer, Belt	163	874 78 04-16	Bolt Hex Fin 1/4-20 Unc x 1 Gr 5
50	874 76 06-24	Bolt, Hex Hd 3/8-16 x 1-1/2	164	819 09 10-10	Washer 5/8 x .281 x 10 Ga
51	873 68 06-00	Nut Crownlock 3/8-16 UNC	165	532 16 56-23	Bracket Pivot Lever
52	873 68 05-00	Nut, Crownlock 5/16-18 Unc	166	532 16 68-80	Screw 5/16-18 x 5/8
53	532 10 57-10	Link, Clutch	168	532 16 54-92	Bolt Shoulder 5/16-18 x .561
55	532 10 57-09	Spring, Return, Clutch	169	532 16 55-81	Plate Fastening
56	817 06 06-20	Screw 3/8-16 x 1-1/4	171	817 49 06-08	Screw Thdrol 3/8-16 x 1/2 TY-TT
57	532 14 02-94	V-Belt	197	532 16 96-13	Nyliner Snap-In 5/8"ID
59	532 16 96-91	Keeper, Center Span	198	532 16 95-93	Washer Nyl 7/8 ID x .105" Hyd
61	817 12 06-14	Screw 3/8-16 x .875	199	532 16 96-12	Bolt Shoulder 5/16-18UNC
62	532 12 48-72	Cover, Pedal	200	872 14 05-08	Bolt Rdhd Sgnk 5/16-18UNC x 1
63	532 18 02-19	Pulley, Engine	202	872 11 06-14	Bolt Carr Sh 3/8-16 x 1-3/4 Gr.5
64	871 17 07-64	Bolt Hex 7/16-20 x 4 Gr. 5	205	819 17 16-16	Washer 17/32 x 1 x 16 Ga.
65	810 04 07-00	Washer	212	532 14 52-12	Nut Hex Flg Lock
66	532 15 47-78	Keeper Belt Engine Hydro	250	817 06 06-12	Screw 3/8-16 x 3/4 Zinc

**NOTE:** All component dimensions given in U.S. inches  
1 inch = 25.4 mm

# REPAIR PARTS

TRACTOR- -MODEL NO. WZ125H42B, PRODUCT NO. 954 56 84-27  
STEERING ASSEMBLY

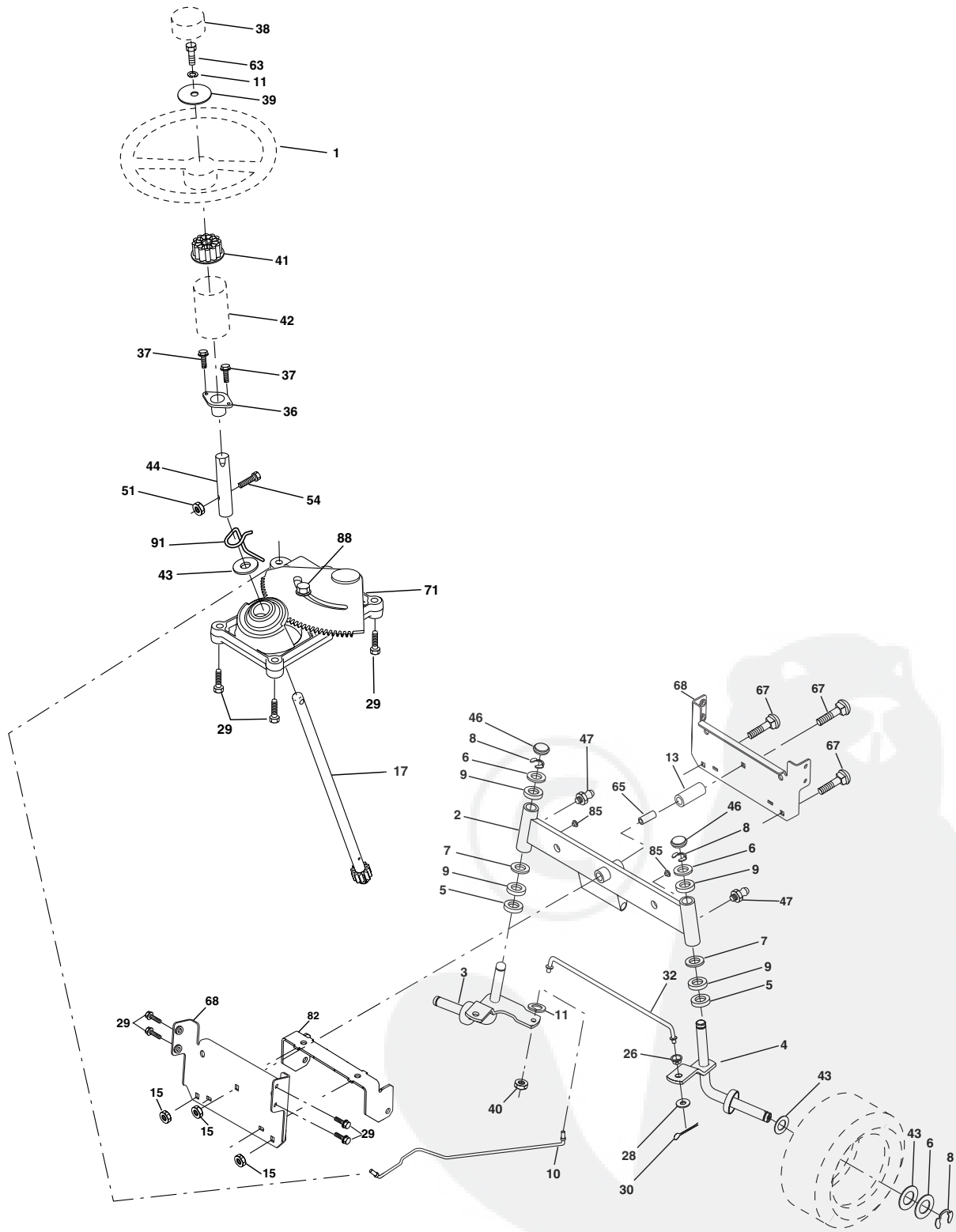

# REPAIR PARTS

## TRACTOR- -MODEL NO. WZ125H42B, PRODUCT NO. 954 56 84-27 STEERING ASSEMBLY

KEY NO.	PART NO.	DESCRIPTION
1	532 17 59-04	Wheel Steering
2	532 17 51-31	Axle Asm Fr
3	532 16 98-40	Spindle Asm LH
4	532 16 98-39	Spindle Asm RH
5	532 12 49-31	Bearing Race Thrust Harden
6	532 12 17-48	Washer 25/32 x 1-5/8 x 16 Ga
7	819 27 20-16	Washer 27/32 x 1-1/4 x 16 Ga
8	812 00 00-29	Ring Klip #t5304-75
9	532 12 49-37	Bearing Col Strg Blk
10	532 17 51-21	Link Drag
11	810 04 06-00	Washer Lock Hvy Hlcl Spr 3/8
13	532 13 65-18	Spacer Brace Axle
15	532 14 52-12	Nut Hexflange Lock
17	532 17 78-76	Shaft Asm Strg
26	532 12 68-47	Bushing Link Drag Blk LR
28	819 13 14-16	Washer 13/32 x 7/8 x 16 Ga
29	817 06 06-12	Screw 3/8-16 x .75
30	876 02 04-12	Pin Cotter 1/8 x 3/4 Cad
32	532 13 04-65	Rod Tie Wire Form 19 75 Mech
36	532 15 50-99	Bushing Strg Nat .623/.618ld
37	532 15 29-27	Screw TT #10-32 x 5 x 3/8 Flange
38	532 17 59-05	Cap Wheel Steer
39	819 13 38-12	Washer 13/32 x 2-3/8 x 12 Ga
40	532 12 47-01	Nut Lock Center 3/8-24unf
41	532 10 07-11	Adaptor Wheel Strg
42	532 16 96-33	Boot Shaft Steering
43	532 12 17-49	Washer 25/32 X 1 1/4 X 16 Ga
44	532 15 37-20	Extension Steering
46	532 12 12-32	Cap Spindle Fr Top Blk
47	532 12 48-36	Fitting Grease
51	873 80 05-00	Nut Lock Hx w/Ins 5/16-18 Unc
54	874 78 05-20	Bolt Fin Hex 5/16-18 Unc x 1-1/4
63	874 78 06-16	Bolt Fin Hex 3/8-16 UNC Gr. 5
65	532 16 03-67	Spacer Brace Axle
67	872 14 06-18	Bolt RDHD SQ 3/8-16 UNC x 2-1/4
68	532 16 98-27	Brace Axle
71	532 17 51-46	Steering Asm.
82	532 16 98-35	Bracket Susp. Chassis Front
85	532 13 38-35	Fastener Christmas Tree
88	532 17 51-18	Bolt Shoulder 7/16-20
91	532 17 55-53	Cup Steering

**NOTE:** All component dimensions given in U.S. inches.  
1 inch = 25.4 mm.



# REPAIR PARTS

TRACTOR- -MODEL NO. WZ125H42B, PRODUCT NO. 954 56 84-27

## DECALS

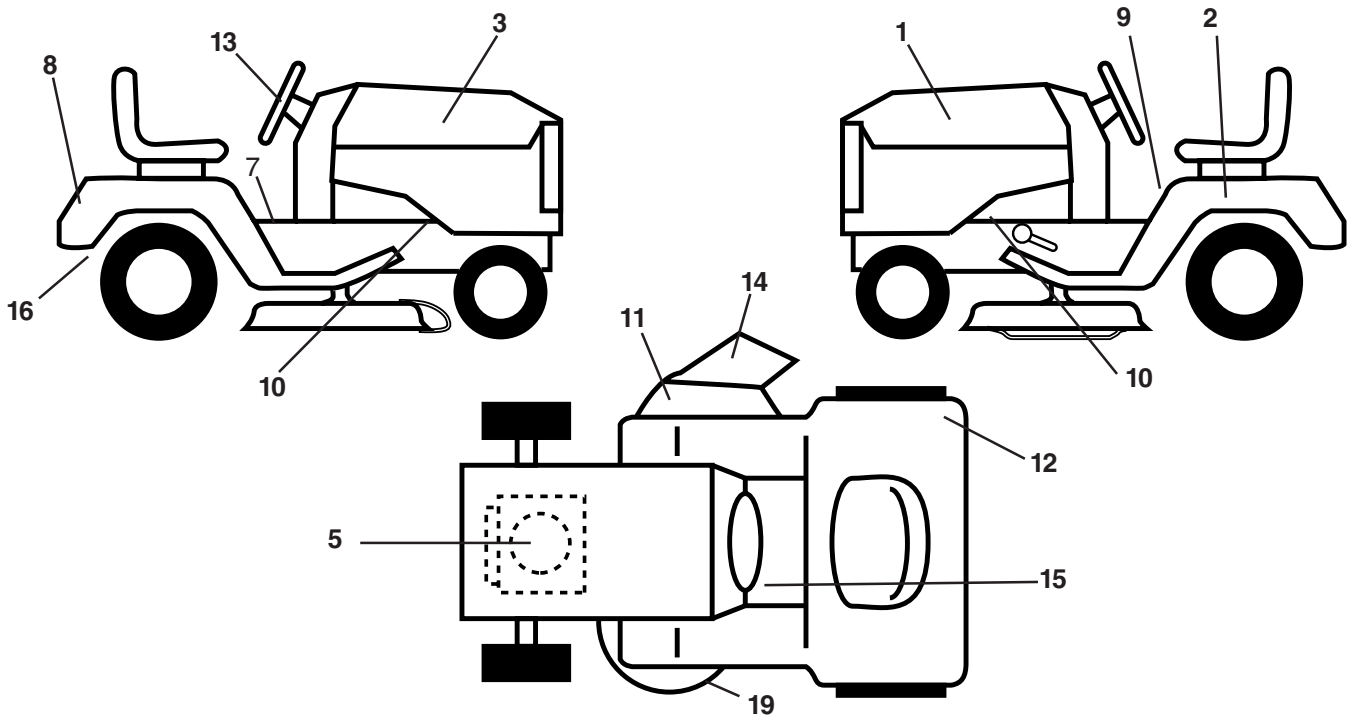

KEY NO.	PART NO.	DESCRIPTION
1	532 17 58-38	Decal Hood LH
2	532 14 50-05	Decal Bat Dan/Poi P/L Symbols
3	532 17 58-37	Decal Hood RH
5	532 17 08-39	Decal Engine
7	532 14 08-37	Decal Saddle Brake Parking
8	532 17 21-75	Decal Fender Bernard
9	532 14 54-98	Decal Read Owners Manual Syms
10	532 15 97-36	Decal Chassis Hot Muffler
11	532 18 21-66	Decal Mower Cut finger Symbol
12	532 18 04-32	Decal 100 DbA/CE
13	532 16 71-08	Decal Strg Wheel Cap

KEY NO.	PART NO.	DESCRIPTION
14	532 17 91-28	Decal Deck "B" 42"
15	532 15 97-37	Decal Brake/Clutch
16	532 16 92-10	Decal By-Pass, Hydro
19	532 16 03-96	Decal V-Belt Sch
--	532 16 25-98	Decal Drawbar Load Limit
--	532 13 83-11	Decal Lift Handle (Lift Handle)
--	532 18 10-91	Pad Footrest Lh
--	532 18 10-90	Pad Footrest Rh
--	532 18 21-93	Manual Operator's Euro
--	532 18 21-95	Manual Operator's Scan
--	532 18 19-85	Manual Parts

## WHEELS & TIRES

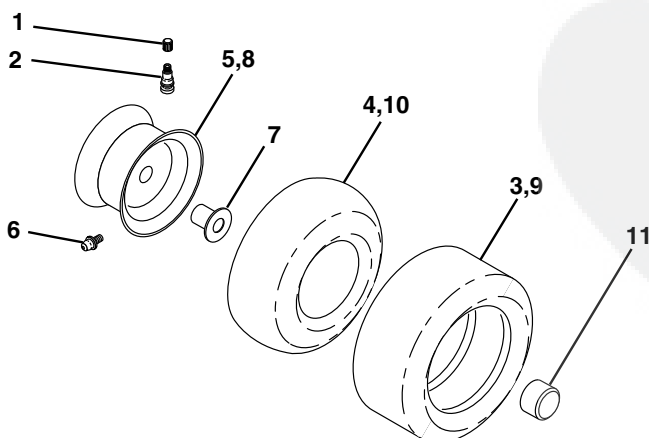

KEY NO.	PART NO.	DESCRIPTION
1	532 05 91-92	Cap Valve Tire
2	532 06 51-39	Stem Valve
3	532 10 62-22	Tire F Ts 15 X 6 0 - 6 Service
4	532 05 99-04	Tube Front (Service Item Only)
5	532 14 14-46	Rim Asm 6" front Service
6	532 12 49-57	Fitting Grease (Front Wheel Only)
7	532 12 49-59	Bearing Flange (Front Wheel Only)
8	532 12 46-35	Rim Asm 8" rear Service
9	532 14 14-47	Tire R Ts 18 x 9.5-8 C. Service
10	532 12 49-26	Tube Rear (Service Item Only)
11	532 17 50-39	Cap Axle Blk 1 50 X 1 00

**NOTE:** All component dimensions given in U.S. inches  
1 inch = 25.4 mm

# REPAIR PARTS

TRACTOR- -MODEL NO. WZ125H42B, PRODUCT NO. 954 56 84-27  
ENGINE

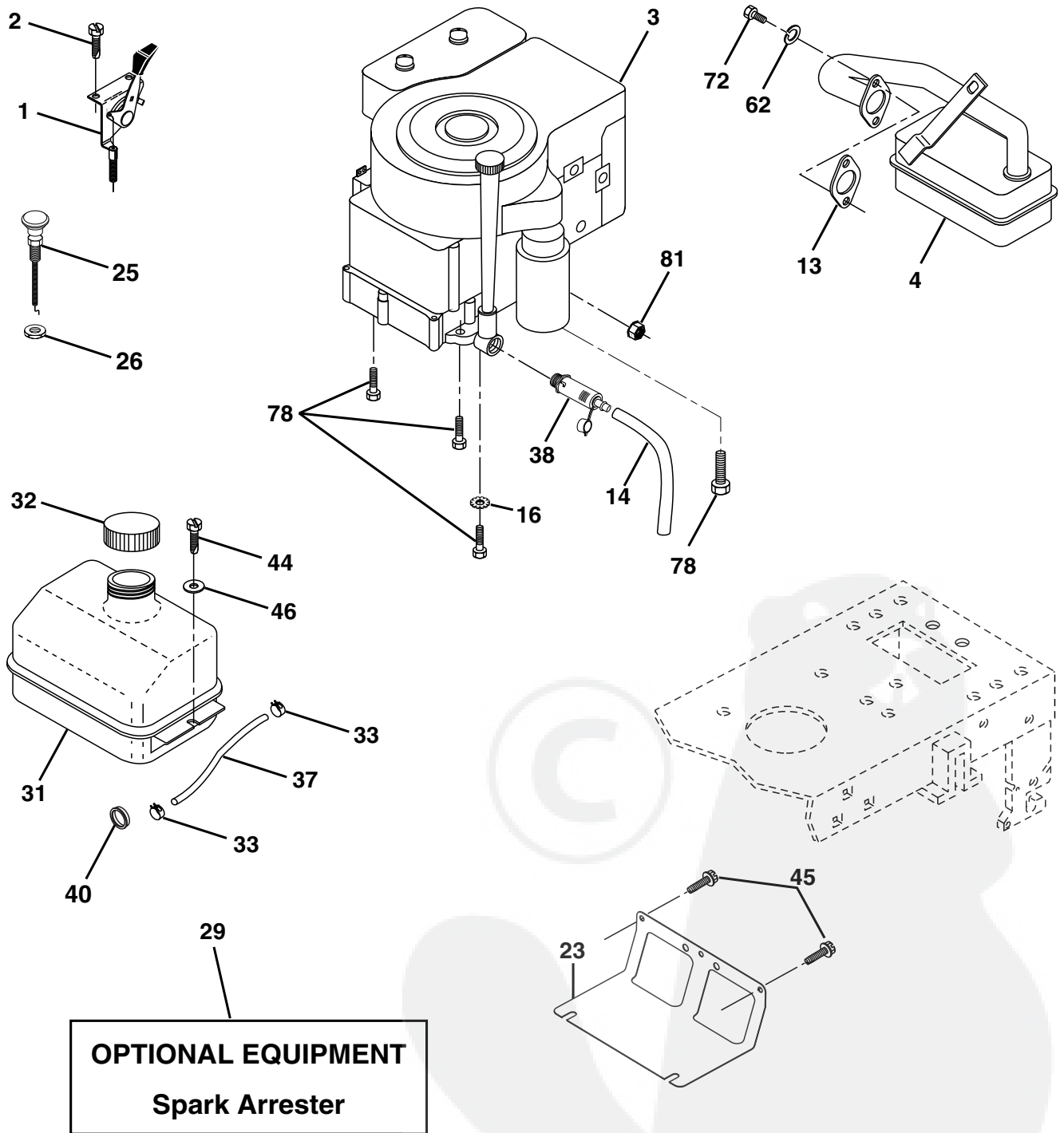

# REPAIR PARTS

TRACTOR- -MODEL NO. WZ125H42B, PRODUCT NO. 954 56 84-27  
ENGINE

KEY NO.	PART NO.	DESCRIPTION
1	532 17 05-51	Control Th/ch Flag
2	817 72 04-08	Screw Hex Thd Cut 1/4-20 x 1/2
3	-----	Engine B&S Model 289707 (Order parts from engine manufacturer)
4	532 13 73-48	Muffler LT B&S 12/12 5 HP
13	532 16 52-87	Gasket Eng
14	532 14 84-56	Tube Drain Oil Easy
16	811 05 06-00	Washer Lock Ext Tooth 3/8
23	532 16 98-37	Sheild Brn/Dbr Guard
25	532 18 09-45	Control Choke
26	873 92 06-00	Nut Keps 3/8-24 Unf
29	532 13 71-80	Kit Spark Arrestor
31	532 10 92-02	Tank Fuel Front 1.25
32	532 14 05-27	Cap Asm Fuel W/sym Vented
33	532 12 34-87	Clamp Hose Blk
37	532 13 70-40	Line Fuel
38	532 14 83-15	Plug Oil Drain Easy
40	532 12 40-28	Bushing Snap Nyl Blk Fuel Line
44	817 67 04-12	Screw Hex wsh Thdrol 1/4-20 x 3/4
45	817 00 06-12	Screw Hex Wsh Thdr 3/8-16 x 3/4
46	819 09 14-16	Washer 9/32 x 7/8 x 16 Ga.
72	871 07-05-12	Screw Hexhd Cap 5/16-18 x 3/4
78	817 06 06-20	Screw 3/8-16 x 1-1/4
81	873 51 04-00	Nut Keps Hex 1/4-20 Unc

**NOTE:** All component dimensions given in U.S. inches  
1 inch = 25.4 mm

# REPAIR PARTS

TRACTOR- -MODEL NO. WZ125H42B, PRODUCT NO. 954 56 84-27  
MOWER LIFT

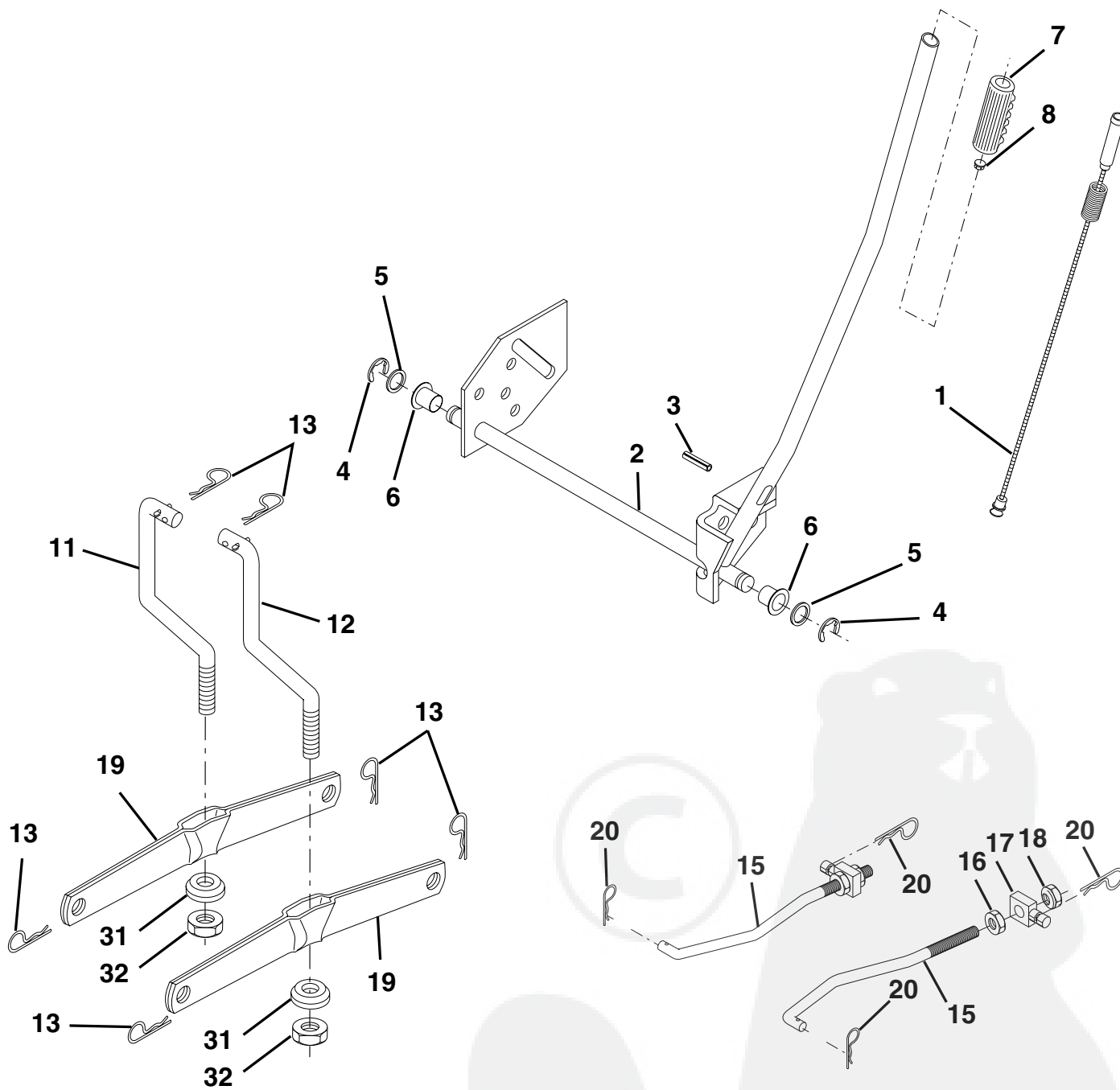



# REPAIR PARTS

TRACTOR- -MODEL NO. WZ125H42B, PRODUCT NO. 954 56 84-27  
MOWER LIFT

KEY NO.	PART NO.	DESCRIPTION
1	532 15 94-60	Wire Asm Inner W/Plunger
2	532 15 94-71	Shaft Asm Lift
3	532 10 57-67	Pin Groove
4	812 00 00-02	E Ring #5133-62
5	819 21 16-21	Washer PLTD 21/32 X 1 X 21ga
6	532 12 01-83	Bearing Nylon Blk 629 Id
7	532 10 94-13	Grip Handle Bicycle Matte Blk
8	532 12 45-26	Button Plunger Black
11	532 13 98-65	Link Lift LH
12	532 13 98-66	Link Lift RH
13	532 12 46-70	Retainer Spring
15	532 17 32-88	Link Front
16	873 35 08-00	Nut Jam Hex 1/2-13 Unc
17	532 17 56-89	Trunnion
18	873 80 08-00	Nut Lock W/wsh 1/2-13 Unc
19	532 13 98-68	Arm Suspension Rear
20	532 16 35-52	Retainer Spring
31	532 16 98-65	Bearing Pvt Lift
32	873 54 06-00	Nut Crownlock 3/8-24

**NOTE:** All component dimensions given in U.S. inches  
1 inch = 25.4 mm





# REPAIR PARTS

TRACTOR- -MODEL NO. WZ125H42B, PRODUCT NO. 954 56 84-27

## MOWER

KEY NO.	PART NO.	DESCRIPTION	KEY NO.	PART NO.	DESCRIPTION
1	532 1658-92	Mower Deck Assembly, 42"	48	532 1339-44	Washer, Hardened
2	872 1405-06	Bolt	49	532 1742-84	Roller Assembly, Cam Follower
3	532 1380-17	Bracket Asm Fr. Sway Bar 3/42	50	532 1313-40	Bolt, Shoulder #10-24 Grade 5
4	532 1654-60	Bracket Asm Deck 42" Sway Bar	51	532 0691-80	Locknut
5	532 1246-70	Retainer Spring	52	532 1398-88	Bolt, Shoulder 5/16-18 UNC
6	532 1780-24	Bar Sway	53	532 1318-45	Arm Assembly, Pad, Brake
8	532 8508-57	Bolt 3/8-24 x 25 Grade 8 patched	54	532 1339-43	Washer, Hardened
9	810 030600	Washer, Lock	55	532 1550-46	Arm, Idler
10	532 1402-96	Washer, Hardened	56	532 1657-23	Spacer, Retainer
11	532 1384-98	Blade Mower 42" Hi-Lift Std	59	532 1410-43	Guard TUV Idler
13	532 1376-45	Shaft Assembly, Mandrel, Vented	67	532 1069-32	Knob Round
14	532 1287-74	Housing, Mandrel, Vented	68	532 1802-15	V-Belt, 42" Mower
15	532 1104-85	Bearing, Ball, Mandrel	142	532 1658-90	Arm Spring Brake Mower
16	532 1744-93	Stripper Mower Deck	143	532 1571-09	Bracket Arm Idler 42"
18	872 1405-05	Bolt, Carriage 5/16-18 x 5/8	144	532 1586-34	Keeper Belt 42" Clutch Cable
19	532 1328-27	Bolt, Shoulder	145	532 1658-88	Pulley Idler Flat
20	532 1597-70	Baffle, Vortex	146	532 1719-77	Bolt Carriage Idler
21	873 6805-00	Nut	147	532 1797-48	Spring Extension
23	532 1775-63	Bracket, Deflector Mower 42"	148	532 1690-22	Spring Return Idler
24	532 1053-04	Cap, Sleeve 80 x 112 Blk Mower	149	532 1658-98	Retainer Spring Yellow
25	532 1237-13	Spring, Torsion, Deflector 2 52	150	819 0912-16	Washer 9/32 x 3/4 x 16 Ga.
26	532 1104-52	Nut, Push Phos & Oil	151	532 1696-70	Bracket Clutch Cable
27	532 1718-59	Shield, Deflector 42" Blk	152	532 1815-55	Clutch Cable 42"
28	819 1110-16	Washer 11/32 x 5/8 x 16 Gauge	153	532 1696-74	Washer Flat 3/8" Type B
29	532 1314-91	Rod, Hinge 42" 6 75 W/G	154	532 1696-75	Spring Retainer
30	532 1739-84	Screw Thdrol	155	532 1696-71	Spring Retention LVR CLTCH CAB
31	532 1299-63	asher, Spacer Mower Vented	156	532 1696-72	Spacer Clutch Cable
32	532 1535-35	Pulley, Mandrel	157	532 1696-69	Rod Clutch Cable 3/8"
33	532 1783-42	Nut, Toplock 9/16	158	817 7204-10	Screw Hex Thd Cut 1/4-20 x 5/8
34	872 1106-14	Bolt	159	872 1406-14	Bolt Rdhd Sqn 3/8-16 UNC x 1-3/4
36	532 1314-94	Pulley, Idler, Flat	--	532 1307-94	Mandrel Assembly (Includes Housing, Shaft and Shaft Hardware Only-Pulley Not Included)
37	819 1313-16	Washer 13/32 x 13/16 x 16 Gauge	--	532 1819-25	Replacement Mower, Complete
40	873 6806-00	Nut			
44	532 1400-88	Guard, Mandrel, LH			
45	532 1247-88	Retainer			
46	532 1377-29	Screw, Thdrol 1/4-20 x 5/8 T			

**NOTE:** All component dimensions given in U.S. inches  
1 inch = 25.4 mm

## LIMITED WARRANTY

The Manufacturer warrants to the original consumer purchaser that this product as manufactured is free from defects in materials and workmanship. For a period of one (1) year from date of purchase by the original consumer purchaser, we will repair or replace, at our option, without charge for parts or labor incurred in replacing parts, any part which we find to be defective due to materials or workmanship. This Warranty is subject to the following limitations and exclusions.

1. This warranty does not apply to the engine. Please contact your nearest dealer where they will send the machine to the engine manufacturer.
2. Transportation charges for the movement of any power equipment unit or attachment are the responsibility of the purchaser. Transportation charges for any parts submitted for replacement under this warranty must be paid by the purchaser unless such return is requested by your dealer.
3. Battery Warranty: On products equipped with a Battery, we will replace, without charge to you, any battery which we find to be defective in manufacture, during the first ninety (90) days of ownership. After ninety (90) days, we will exchange the Battery, charging you 1/12 of the price of a new Battery for each full month from the date of the original sale. Battery must be maintained in accordance with the instructions furnished.
4. The Warranty period for any products used for rental or commercial purposes is limited to 90 days from the date of original purchase.
5. This Warranty applies only to products which have been properly assembled, adjusted, operated, and maintained in accordance with the instructions furnished. This Warranty does not apply to any product which has been subjected to alteration, misuse, abuse, improper assembly or installation, delivery damage, or to normal wear of the product.
6. Exclusions: Excluded from this Warranty are belts, blades, blade adapters, normal wear, normal adjustments, standard hardware and normal maintenance.
7. In case of any problem within the boundaries of this warranty, contact the nearest department store, indicate the model number, serial number and the date of purchase of your machine. This warranty does not apply to accidental damages. All implicit warranties are limited to the same time frames. Or contact:

E.M. Services  
54 Rue Lambrechts  
92400 Courbevoie  
France  
Telephone: (1) 46678078  
Fax: (1) 46678095

THIS WARRANTY DOES NOT APPLY TO INCIDENTAL OR CONSEQUENTIAL DAMAGES. ANY IMPLIED WARRANTIES ARE LIMITED TO THE SAME TIME PERIODS STATED HEREIN.



**WIZARD**