



**REPAIR  
PARTS MANUAL  
MODEL NO. WZ1842RDHA  
Lawn Tractor**

---

**WIZARD**

# HOW TO USE THIS MANUAL

This manual is designed to provide the customer with a means to identify the parts on his/her tractor when ordering repair parts. The illustrations may or may not represent the actual assemblies; therefore, it is not recommended to use this manual as a guide to assemble or disassemble the tractor. Some hardware and parts are drawn larger in order to more readily identify them.

Each tractor has its own model number.

The model number for your tractor can be found on the fender under the seat.

When ordering parts, always give the following information:

- Product - "Tractor"
- Model Number - "WZ1842RDHA"
- Part Number
- Part Description

## TABLE OF CONTENTS

SCHEMATIC.....	3
ELECTRICAL.....	4-5
CHASSIS.....	6-7
DRIVE.....	8-9
STEERING.....	10-11
SEAT.....	12
DECALS.....	13
ENGINE.....	14-15
MOWER LIFT.....	16-17
MOWER DECK.....	18-19
BAGGER.....	20-21
WARRANTY.....	23

# REPAIR PARTS

## TRACTOR- -MODEL NO. WZ1842RDHA

### SCHEMATIC

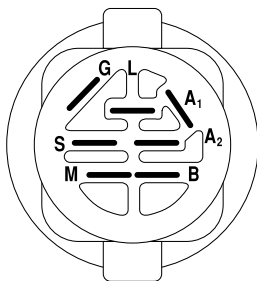
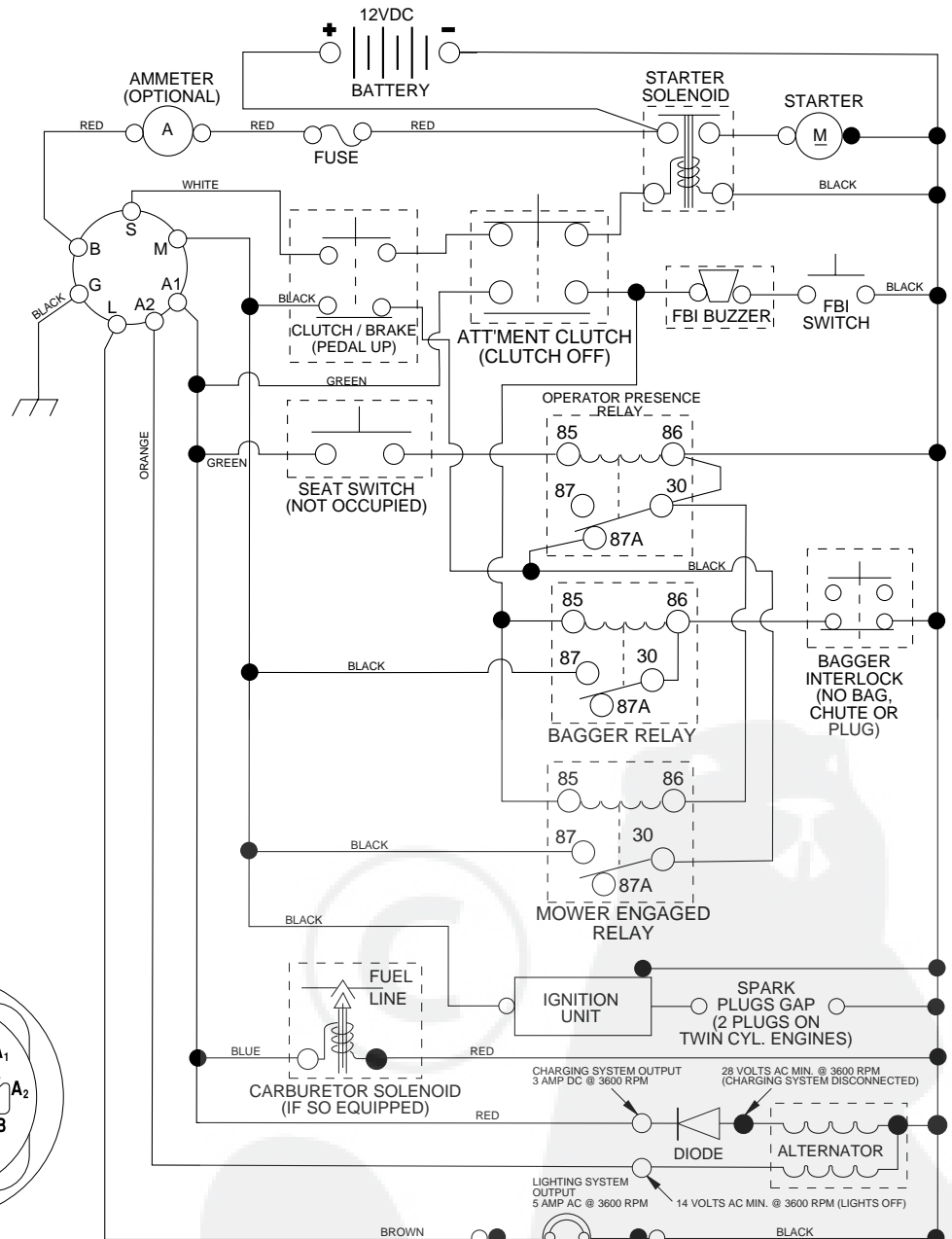

**IGNITION SWITCH**

POSITION	CIRCUIT	"MAKE"
OFF	M+G+A1	NONE
RUN/LIGHT	B+A1	A2+L
RUN	B+A1	NONE
START	B + S + A1	NONE

**WIRING INSULATED CLIPS**  
**NOTE:** IF WIRING INSULATED CLIPS WERE REMOVED FOR SERVICING OF UNIT, THEY SHOULD BE REPLACED TO PROPERLY SECURE YOUR WIRING.

● NON-REMOVABLE CONNECTIONS

○ REMOVABLE CONNECTIONS

**PTO SWITCH**

POSITION	CIRCUIT
OFF	C + G, B + H
ON	C + F, B + E, A + D

**HEADLIGHTS**

**NOTE**  
 YOUR TRACTOR IS EQUIPPED WITH A SPECIAL ALTERNATOR SYSTEM. THE LIGHTS ARE NOT CONNECTED TO THE BATTERY, BUT HAVE THEIR OWN ELECTRICAL SOURCE. BECAUSE OF THIS, THE BRIGHTNESS OF THE LIGHTS WILL CHANGE WITH ENGINE SPEED. AT IDLE THE LIGHTS WILL DIM. AS THE ENGINE IS SPEEDED UP, THE LIGHTS WILL BECOME THEIR BRIGHTEST.



**RELAY**

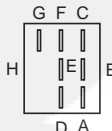



# REPAIR PARTS

## TRACTOR- -MODEL NO. WZ1842RDHA

### ELECTRICAL

KEY NO.	PART NO.	DESCRIPTION
1	144925	Battery 12 Volt 25 AMP Wet
2	74760412	Bolt Hex Hd 1/4-20 Unc X 3/4
16	153664	Switch Interlock Push-In
21	166181	Harness Asm Light W/4152J
22	4152J	Bulb Light #1156
24	4799J	Cable Battery 6 Ga 11" Red
25	165987	Cable Battery Crd 56" Red
26	175158	Fuse 20 Amp
27	73510400	Nut Keps Hex 1/4-20 Unc
28	127725X	Cable Ground 6Ga 18" Black
29	160784	Switch Plunger Normal Op Olive
30	175566	Switch Ignition
33	140401	Key Ign Molded
40	170164	Harness Ign Crd Noram
41	71110408	Bolt Flk Fin Hex 1/4-20 Unc X 1/2
42	131563	Cover Terminal Red
43	178861	Solenoid
48	140844	Adapter Ammeter Rectangular
52	141940	Protection Wire Loop
58	169419	Buzzer Crd
59	166299	Switch FBI CRD
65	17211008	Screw Slftp #10-16 x 1/2 Ty-Ab
66	17490608	Screw Thdrol 3/8-16 x 1/2 Ty-Tt
81	109748X	Relay Asm

**NOTE:** All component dimensions given in U.S. inches.  
1 inch = 25.4 mm.

# REPAIR PARTS

## TRACTOR- -MODEL NO. WZ1842RDHA

### CHASSIS AND ENCLOSURES

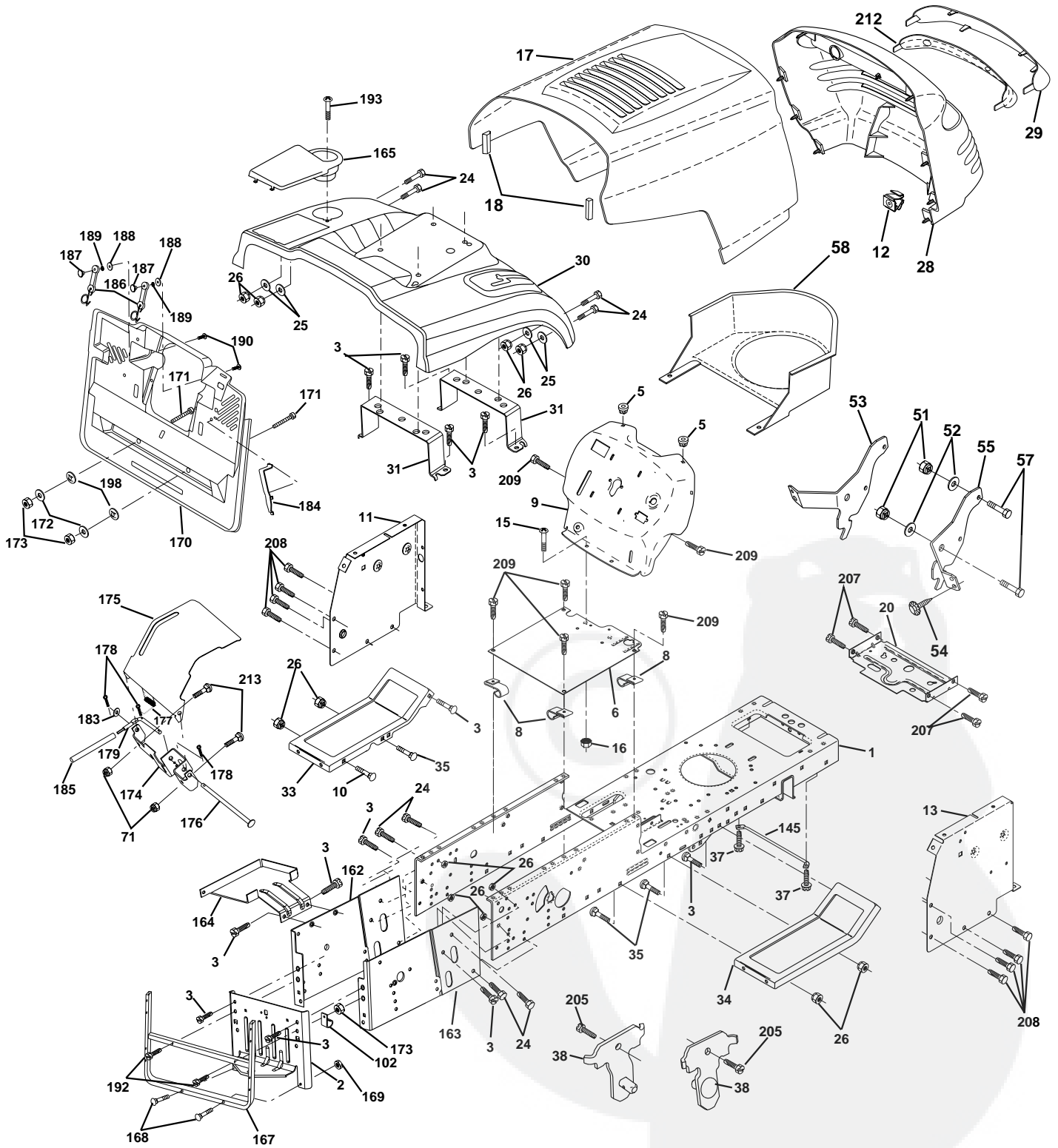

# REPAIR PARTS

## TRACTOR- -MODEL NO. WZ1842RDHA

### CHASSIS AND ENCLOSURES

KEY NO.	PART NO.	DESCRIPTION	KEY NO.	PART NO.	DESCRIPTION
1	169831	Chassis Stamping	145	156524	Rod Pivot Chassis/Hood
2	165606	Drawbar	162	170256	Bracket Exten Chassis Lh CRD
3	17060612	Screw 3/8-16 x 3/4	163	175770	Bracket Exten Chassis Rh CRD
5	155272	Bumper Hood/Dash	164	165605	Support Battery CRD
6	155923	Saddle	165	165742X428	Cover Battery CRD Lt
8	126471X	Clip Insulator 13/32 Mtg. Hole	167	165779	Support Asm. Backplate LDMNT
9	168347X011	Dash	168	72050412	Bolt, RD HD SHT NK 1/4-20 x 1-1/2
10	72140608	Bolt, Carriage 3/8-16 x 3/4	169	123976X	Nut, Lock 1/4 LGE FLG Gr. 5 Zinc
11	155927	Panel, Dash, L.H.	170	175264	Backplate
12	145660	Clip Tinnerman Grille P/L	171	72140620	Bolt Hex 3/8-16 x 2-1/2 Gr 5
13	172107X010	Panel, Asm. Dash R.H.	172	19132016	Washer 13/32 x 1-1/4 x 16 Ga.
15	74180512	Screw, Machine, Truss Head 5/16-18 UNC x 3/4	173	73510600	Nut, Keps Hex 3/8-16 UNC
16	73510500	Nut	174	165939	Bracket Switch FBI CRD
17	159639X505	Hood Assembly	175	166212	Guard Door Rear CRD
18	126938X	Bumper Hood	176	128600	Pin Hinge Pivot
20	156437	Plate Mtg. Battery/Fuel Tank	177	132796	Spring Bagger Top LH Black
24	74780616	Bolt	178	76020312	Pin Cotter 3/32 x 3/4 Cad Zinc
25	19131312	Washer 13/32 x 13/16 x 12 Gauge	179	165942	Rod Pivot FBI CRD
26	73800600	Nut	183	19131316	Washer 13/32 x 13/16 x 16 Ga.
28	140434	Grille PL	184	174662	Bracket Actuator Bagger CRD
29	140273X599	Lens, Grille	185	165940	Tube Lever Switch FBI CRD
30	170139X505	Fender	186	160793	Latch Asm Mulch/Bagger
31	165156	Bracket, Fender Support	187	2029J	Nut Weld
33	145244X505	Footrest, L.H.	188	19061216	Washer #10
34	145243X505	Footrest, R.H.	189	10071000	Washer Lock #10
35	72110606	Bolt	190	71081010	Screw Pan Hd Phil 10-24 x 5/8
37	17490508	Screw Thdrol 5/16-18 x 1/2 TYT	192	17060624	Screw 3/8-16 x 1-1/2
38	175710	Bracket Asm Pivot Mower Rear	193	17070412	Screw Pan 1/4-20 x 3/4 Tap/R
51	73800400	Nut Lock w/Insert 1/4-20 UNC	198	168937	Nut, Push
52	19091416	Washer 9/32 x 7/8 x 16 Ga.	205	17490608	Screw Thdrol 3/8-16 x 1/2
53	144697	Bracket Grille LH	207	17670508	Screw Thdrol 5/16-18 x 1/2
54	161464	Screw Hex Wshd 8-18 x 7/8	208	17670608	Screw Thdrol 3/8-16 x 1/2
55	144696	Bracket Grille RH	209	17000612	Screw Hexwsh Thdr 3/8-16 x 3/4
57	74780412	Bolt, Fin Hex 1/4-20 UNC x .75	212	156229	Insert Lens Reflect
58	174930	Duct Air Engine	213	72110406	Bolt Carr
71	73680400	Nut Crownlock 1/4-20	--	5479J	Plug, Button
102	2751R	Clip Line Fuel 13/32 Mtg. Hole			

**NOTE:** All component dimensions given in U.S. inches.  
1 inch = 25.4 mm.

# REPAIR PARTS

## TRACTOR- -MODEL NO. WZ1842RDHA

### DRIVE

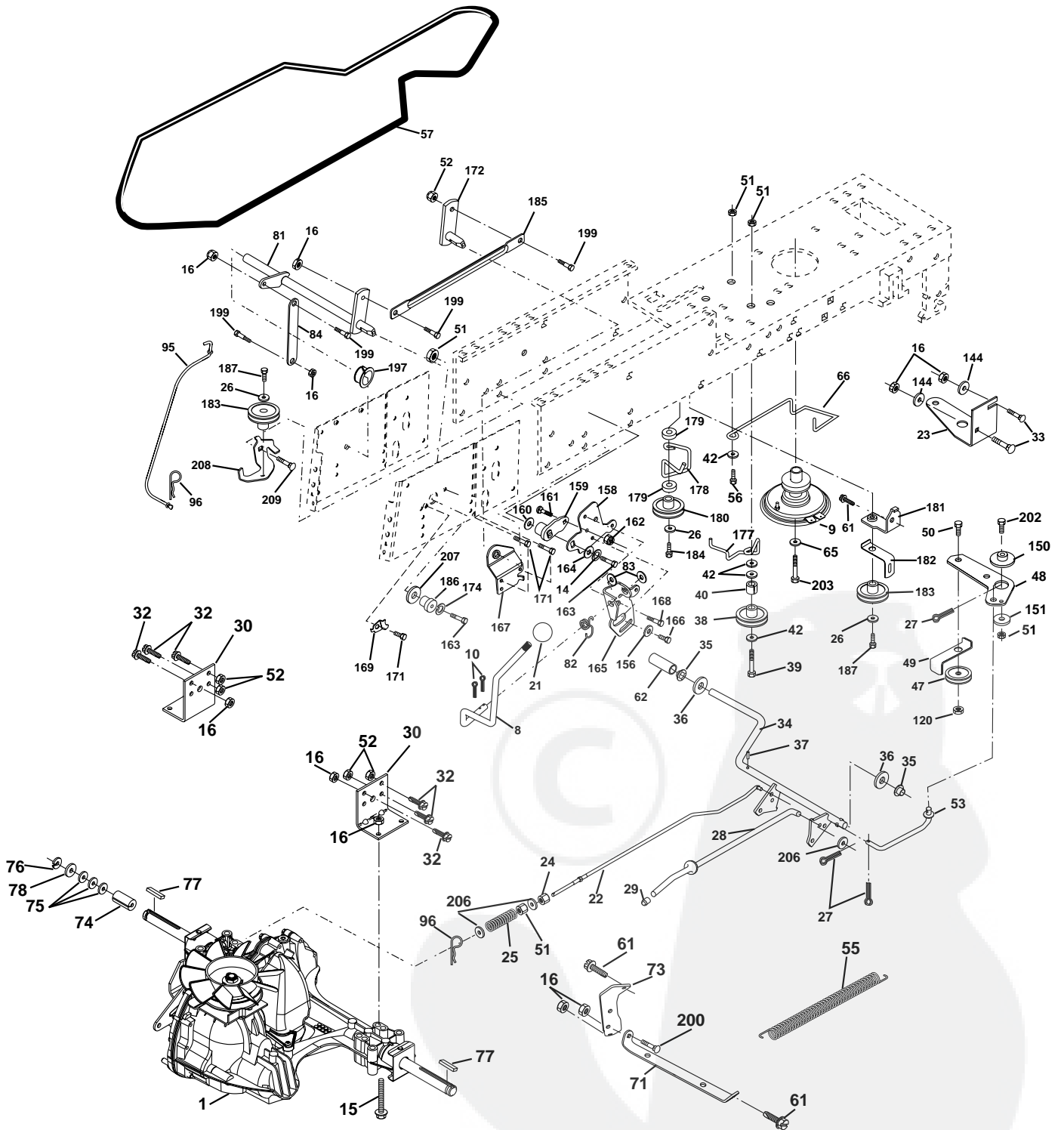



# REPAIR PARTS

## TRACTOR- -MODEL NO. WZ1842RDHA

### DRIVE

KEY NO.	PART NO.	DESCRIPTION	KEY NO.	PART NO.	DESCRIPTION
1	-----	Transaxle Hydro Gear 321-0510 (Order parts from transaxle manufacturer)	78	121748X	Washer 25/32 x 1-5/8 x 16 Ga.
3	143995	Pulley Hydro 0650 Lt/CRD	81	170006	Asm, Shaft
8	165619	Rod, Shift Fender Adjust Lt	82	123782X	Spring, Torsion
9	170163	Clutch Asm Noram	83	19171216	Washer 17/32 x 3/4 x 16 Ga.
10	76020416	Pin, Cotter 1/8 x 1	84	170007	Link, Transaxle
14	10040400	Washer, Lock Hvy Helical	95	170015	Rod Bypass Hydro
15	74490544	Bolt Hx Flhd 5/16-18	96	4497H	Spring, Retainer 1"
16	73800500	Nut, Lock Hex w/Ins 5/16-18 UNC	102	141322	Washer, Bellville .50ID x 1.50D
21	130564	Knob Round 1/2-13 UNC	120	73900600	Nut Lock Flg 3/8-16
22	170137	Rod, Brake CRD	144	19111016	Washer 11/32 x 5/8 x 16 Ga
23	170017	Bracket Clutch Noram	150	165850	Bushing, Bellcrank Grnd Dr
24	73350600	Nut	151	19133210	Washer 13/32 x 2 x 10 Ga.
25	106888X	Spring, Rod, Brake	156	166002	Washer Srrted 5/16ID x 1.125
26	19131316	Washer 13/32 x 13/16 x 16 Ga.	158	165589	Bracket Shift Mount
27	76020412	Pin, Cotter 1/8 x 3/4	159	165494	Hub Tapered Flange Shift Lt
28	145204	Rod, Parking Brake	160	19292016	Washer 29/32 x 1-1/4 x 16 Ga.
29	71673	Cap, Parking Brake	161	72140406	Bolt Rdhd Sqnk 1/4-20 x 3/4 Gr 5
30	169592	Bracket, Mfg. Transaxle	162	73680400	Nut Crownlock 1/4-20 Unc
32	74760512	Bolt Hex 5/16-18 UNC x 3/4	163	74780416	Bolt Hex Fin 1/4-20 Unc x 1 Gr 5
33	72140506	Bolt Rdhd Sqnk 5/16-18 Unc x 3/4	164	19091010	Washer 5/8 x .281 x 10 Ga.
34	165496	Shaft, Asm Pedal Foot CRD	165	165623	Bracket Pivot Lever
35	120183X	Bearing, Nylon	166	166880	Screw 5/16-18 x 5/8
36	19211616	Washer 21/32 x 1 x 16 Ga.	167	165588	Bracket Support Shift CRD
37	1572H	Pin, Roll 3/16 x 1"	168	165492	Bolt Shoulder 5/16-18 x .561
38	165936	Pulley Flat Composite 3.06"	169	165580	Plate Fastening Lt
39	74760644	Bolt Fin Hex 3/8-16 x 2-3/4	171	17490608	Screw Thdrol 3/8-16 x 1/2 Ty-Tt
40	4470J	Spacer, Split 395 x 59 Bzp	172	170271	Shaft Asm Shifter Frt CRD 0510
42	19131312	Washer 13/32 x 13/16 x 12 Ga.	174	10090400	Washer Lock 1/4
47	127783	Pulley, Idler, V Groove Plasitc	177	165932	Keeper Flat Idler 3.06" CRD
48	154407	Bellcrank Clutch Grnd Drv	178	165933	Keeper Belt Idler 1.88" CRD
49	123205X	Retainer, Belt Style Spring	179	120958X	Washer Sintered
50	74760624	Bolt Hex Hd 3/8-16 UNC x 1-1/2	180	165630	Pulley, Idler, Flat 1.88"CRD
51	73680600	Nut, Crownlock 3/8-16 UNC	181	165797	Bracket Idler Ground Drive CRD
52	73680500	Nut Crownlock 5/16-18	182	165634	Keeper Belt 2.5" Od V-Idler CRD
53	105710X	Link, Clutch 7.66	183	165626	Pulley V-Idler 2.50" Od CRD
55	105709X	Spring, Return, Clutch	184	17490644	Screw Hexwsh Thdrol 3/8-16 x 2-3/4
56	74760620	Bolt, Hex 3/8-16 UNC x 1-1/4	185	170008	Link Shift CRD Hydro 0510
57	170140	V-Belt Kev CRD	186	165614	Hub Tapered Round CRD
61	17060612	Screw 3/8-16 x 3/4	187	17490620	Screw Thdrol 3/8-16 x 1-1/4 TT
62	8883R	Cover, Pedal	197	169613	Nyliner Snap-In 5/8
65	10040700	Washer	199	169612	Bolt Shoulder 5/16-18
66	154778	Keeper, Belt Engine F-Proof	202	72110612	Bolt Carr 3/8-16 x 1-1/2 Gr5
71	169183	Strap, Torque, Lh	203	71170780	Bolt Hex 7/16-20 x 5
73	169182	Strap, Torque, Rh	206	19131416	Washer 10/32 x 7/8 x 16 Ga.
74	137057	Spacer, Split	207	169845	Washer Nylon Rear 0510
75	121749X	Washer 25/32 x 1-1/4 x 16 Ga.	208	169844	Bracket Idler Rear LH
76	12000001	Ring, E	209	72110606	Bolt Rdhd 3/8-16 x 3/4
77	123583X	Key, Square			

**NOTE:** All component dimensions given in U.S. inches  
1 inch = 25.4 mm

# REPAIR PARTS

## TRACTOR- -MODEL NO. WZ1842RDHA

### STEERING ASSEMBLY

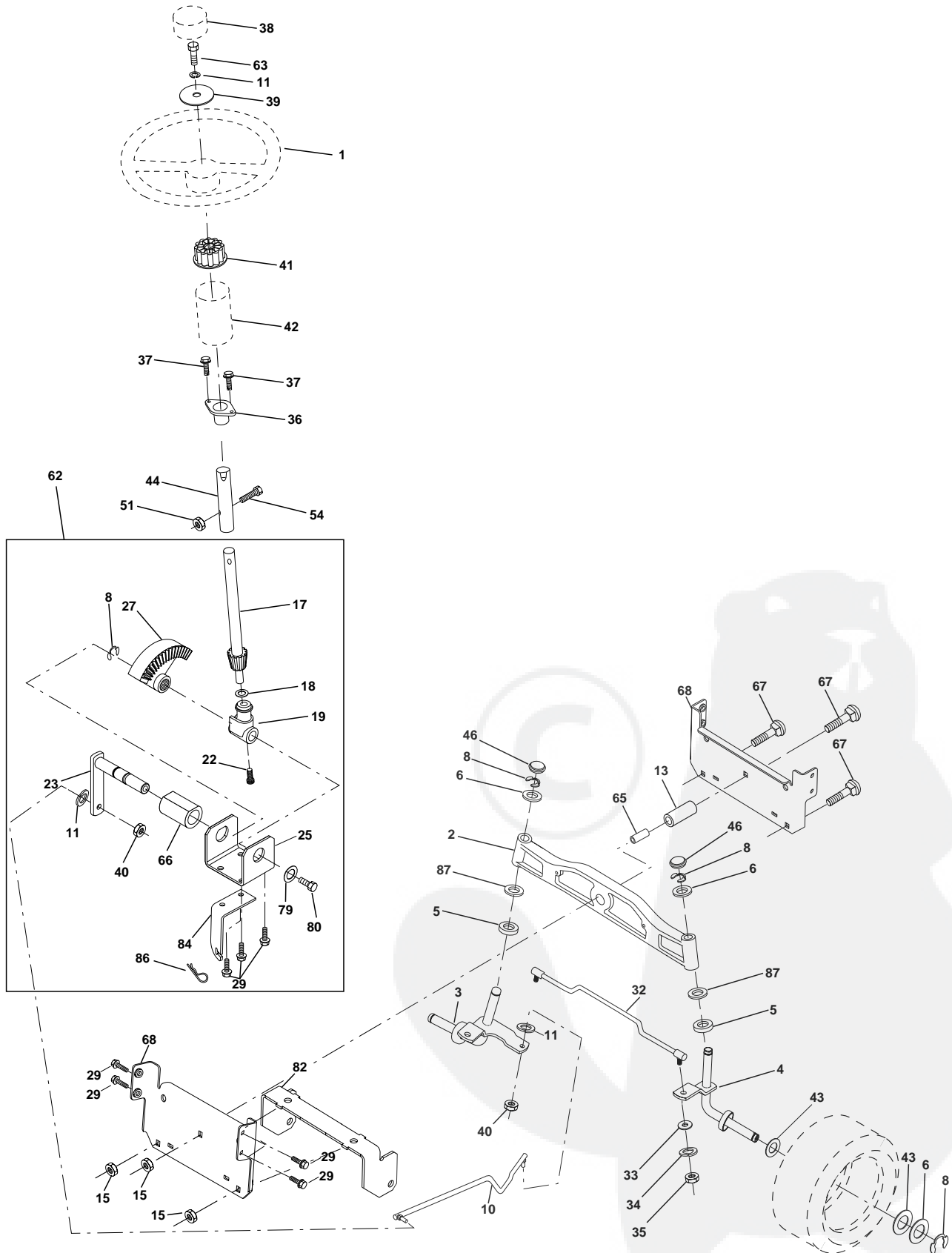

# REPAIR PARTS

## TRACTOR- -MODEL NO. WZ1842RDHA

### STEERING ASSEMBLY

KEY NO.	PART NO.	DESCRIPTION
1	140044X428	Steering Wheel
2	172393	Cast Lt Machined
3	169840	Spindle Assembly, L.H.
4	169839	Spindle Assembly, R.H.
5	6266H	Washer, Thrust .75 x 1.230
6	121748X	Washer 25/32 x 1-5/8 x 16 Gauge
8	12000029	Ring, Klip
10	169832	Link, Drag
11	10040600	Washer, Lock
13	136518	Spacer Brg Axle Front
15	145212	Nut, Hex Flange Lock
17	156546	Shaft Assembly, Steering
18	57079	Washer, Thrust .515 x .750 x .033
19	160395	Support, Shaft
22	165857	Screw Hex Wshhd Torx
23	165851	Pittman Shaft Assembly
25	154406	Bracket, Steering
27	136874	Gear, Sector
29	17060612	Screw 3/8-16 x 3/4
32	170162	Rod, Tie
33	19111216	Washer 11/32 x 3/4 x 16 Ga
34	10040500	Washer Lock Hvy Hlcl Spr 5/16
35	73540500	Nut Crownlock 5/16-24 Unf
36	155099	Bushing, Steering
37	152927	Screw TT #10-32 x 5 x 3/8 Flange
38	140045X428	Cap Wheel Steering
39	19133812	Washer 13/32 x 2-3/8 x 12 Gauge
40	7810H	Nut Lock Center 3/8-24 Unf
41	100711L	Adaptor, Steering Wheel
42	145054X428	Boot, Steering Dash P/L Mtl
43	121749X	Washer 25/32 x 1-1/4 x 16 Gauge
44	153720	Extension Steering Non-Adjust
46	121232X	Cap, Spindle
51	73800500	Nut Lock Hx W/Ins 5/16-18 UNC
54	74780520	Bolt Fin Hex 5/16-18 UNC x 1-1/4
62	167902	Kit, Steering Assembly, Service
63	74780616	Bolt Fin Hex 3/8-16 unc. x 1 Gr. 5
65	160367	Spacer Brace Axle
66	154404	Bearing Arm Pittman
67	72140618	Bolt Rdhd Sqnk 3/8-16unc x 2-1/4
68	169827	Brace Axle
79	19132012	Washer 13/32 x 1-1/4 x 12 Ga
80	74950612	Bolt Hex Nylon 3/8-16 x 3/4
82	169835	Bracket Susp Chassis Front 15"
84	170016	Bracket Cable Clutch Chassis
86	165898	Retainer Spring
87	173966	Washer Flat .781 x 1-1/2 x .14

**NOTE:** All component dimensions given in U.S. inches.  
1 inch = 25.4 mm.

# REPAIR PARTS

## TRACTOR- -MODEL NO. WZ1842RDHA

### SEAT ASSEMBLY

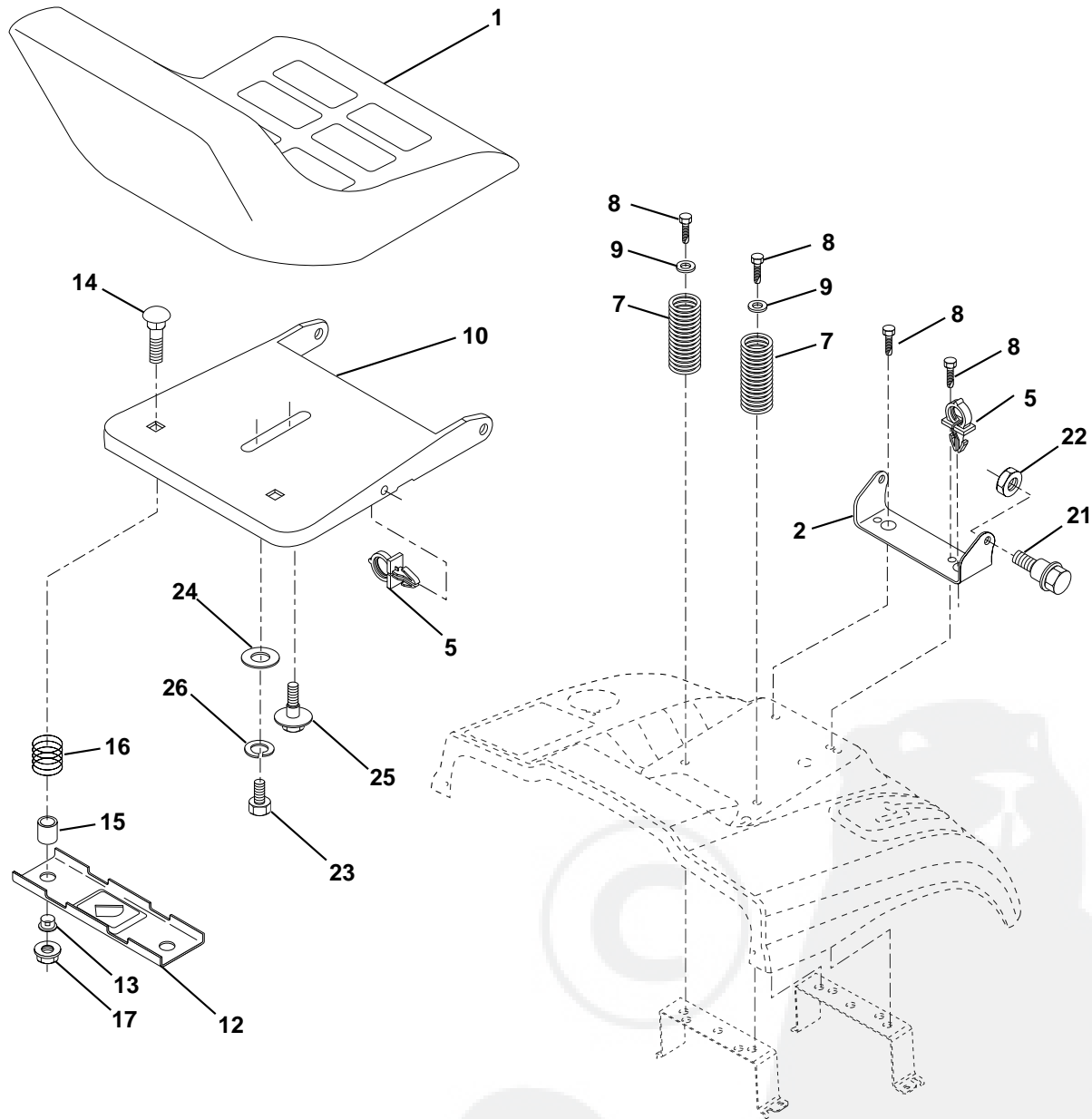

KEY NO.	PART NO.	DESCRIPTION
1	127428	Seat
2	140551	Bracket Pnt Pivot Seat (blk )
5	145006	Clip Push In Hinged
7	124181X	Spring Seat Cprsn 2 250 Blk Zi
8	17000616	Screw 3/8-16 X 1-1/2
9	19131614	Washer 13/32 X 1 X 14 Ga
10	174894	Pan Pnt Seat (blk )
12	121246X	Bracket Pnt Mounting Switch
13	121248X	Bushing Snap Blk Nyl 50 Id
14	72050412	Bolt Rdhd Sht Nk 1/4-20x1-1/2

KEY NO.	PART NO.	DESCRIPTION
15	134300	Spacer Split
16	121250X	Spring Cprsn Plate SW 1.310 Ga
17	123976X	Nut Lock 1/4 Lge Flg Gr 5 Zinc
21	171852	Bolt Shoulder 5/16-18 Unc-2A
22	73800500	Nut Hex Lock w/Ins 5/16-18
23	71110814	Bolt Hex
24	19171912	Washer 17/32 X 1-3/16 X 12 Ga.
25	127018X	Bolt Shoulder 5/16-18 X 62
26	10040800	Washer Lock Hvy Hlcl Spr 1/2

**NOTE:** All component dimensions given in U.S. inches.  
1 inch = 25.4 mm

# REPAIR PARTS

## TRACTOR- -MODEL NO. WZ1842RDHA

### DECALS

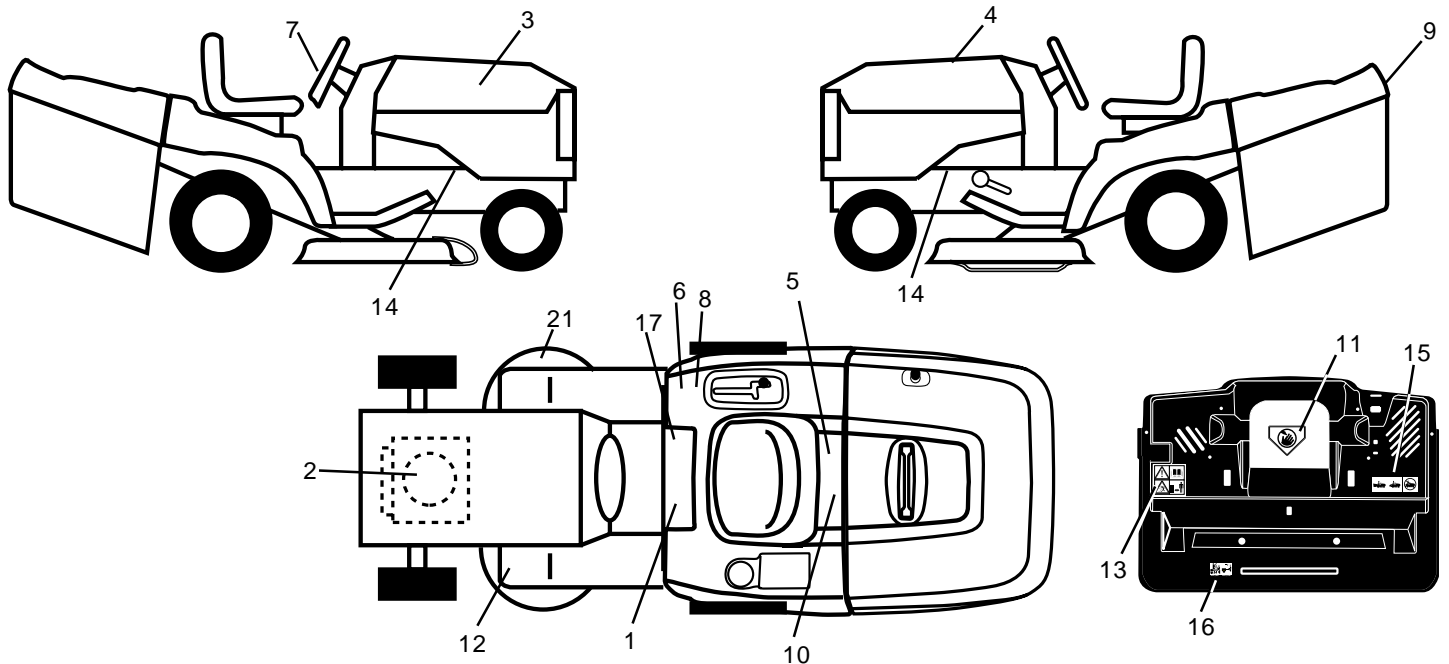

KEY NO.	PART NO.	DESCRIPTION
1	145498	Decal Read Owner's Manual Sym
2	170850	Decal Hp Engine
3	176002	Decal Hood Rh
4	176003	Decal Hood Lh
5	166960	Decal Bypass Fender
6	126187X	Decal 100 DBA
7	167108	Decal Ins Strg Whl
8	145437	Decal Europe Stand Ce
9	163769	Decal Fender Logo
10	145005	Decal Bat Dan/Poi P/L Sym Wpn
11	145494	Decal Mower Cut Finger Symbol

KEY NO.	PART NO.	DESCRIPTION
12	159737	Decal Brake/Clutch Symbol Lt
13	166959	Decal Warn Back Plate CRD
14	159736	Decal Chassis Hot Muffler
15	166961	Decal Oper Bag Presence CRD
16	162598	Decal Drawbar Load Limit
17	140837	Decal Saddle Brake Parking
21	166286	Decal Deck Sch 92 CRD
--	133671	Pad Footrest
--	138311	Decal Lift Handle
--	176194	Manual Operator's (Euro)
--	176195	Manual Operator's (Scan)
--	176196	Manual Parts

### WHEELS & TIRES

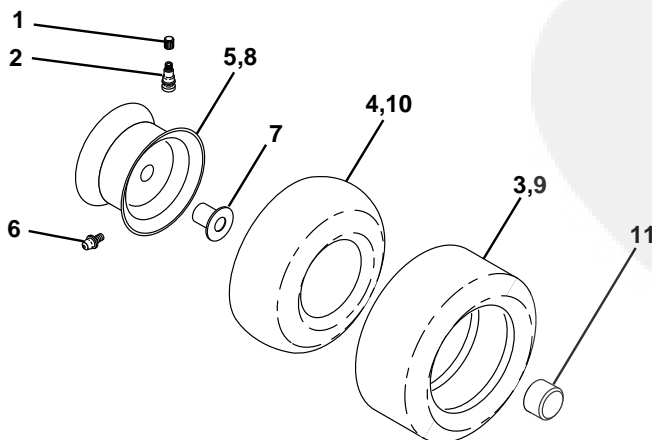

KEY NO.	PART NO.	DESCRIPTION
1	59192	Cap Value Tire
2	65139	Stem Value
3	106222X	Tire F Ts 15 X 6 0 - 6 Service
4	59904	Tube Inner Front #35060
5	106732X427	Rim Asm 6"front Service
6	278H	Fitting Grease
7	9040H	Bearing Flange
8	106108X427	Rim Asm 8"rear Service
9	138468	Tire R Ts 20 x 8-8 Service
10	7152J	Tube Rear 9 5 X 8 Service
11	104757X428	Cap Axle Blk 1 50 X 1 00
--	144334	Sealant, Tire (10 oz. tube)

**NOTE:** All component dimensions given in U.S. inches  
1 inch = 25.4 mm

# REPAIR PARTS

TRACTOR- -MODEL NO. WZ1842RDHA

## ENGINE

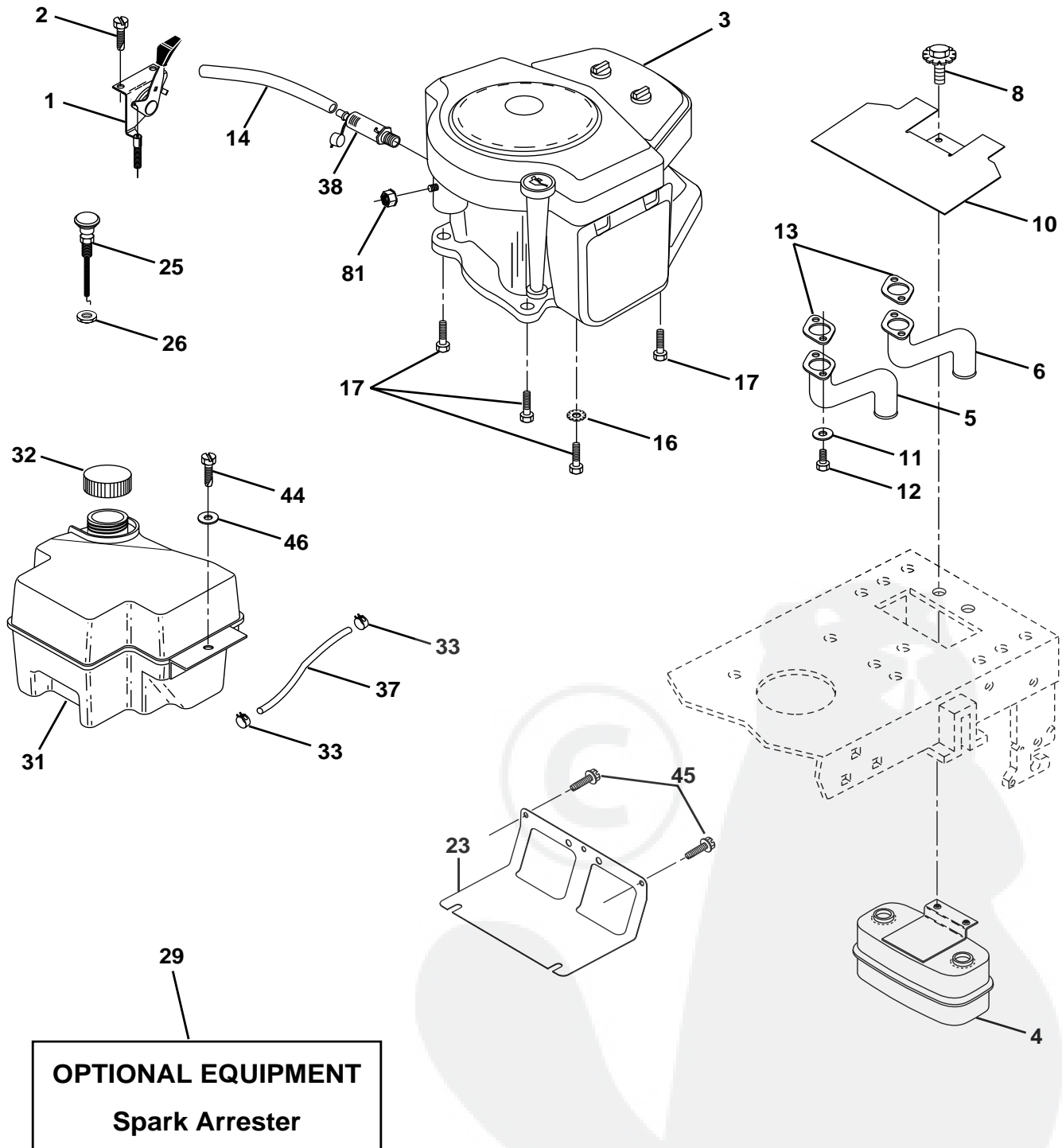

# REPAIR PARTS

## TRACTOR- -MODEL NO. WZ1842RDHA

### ENGINE

KEY NO.	PART NO.	DESCRIPTION
1	170771	Control Throt/Ch
2	17720410	Screw Hex Thd Cut 1/4-20x5/8 T
3	-----	Engine Briggs Model 407777 (Order Parts from Engine Manufacturer)
4	149723	Muffler
5	160589	Exhaust Tube Rh
6	159955	Exhaust Tube Lh
8	171877	Bolt 5/16-18 x 3/4
10	145552	Shield Heat
11	10040500	Washer Lock 5/16
12	71070512	Screw Hx Hd 5/16-18 x 3/4
13	165391	Gasket
14	148456	Tube Drain Oil Easy
16	11050600	Washer Lock Ext Tooth 3/8
17	17490624	Screw Thdrol 3/8-16 x 1-1/2
23	169837	Shield Browning/Debris Guard
25	145996	Control, Choke
26	73920600	Nut Keps 3/8-24
29	137180	Arrestor Spark
31	174642	Tank Fuel 2.00 Fr
32	140527	Cap Asm Fule Top Vent N/Lany
33	123487X	Clamp Hose Blk
37	137040	Line Fuel 20"
38	148315	Plug Drain Oil Easy
44	17670412	Screw Hexwsh Thdrol 1/4-20 x 3/4
45	17000612	Screw Hexwsh Thdr 3/8-16 x 3/4
46	19091416	Washer 9/32 X 7/8 X 16ga
81	73510400	Nut Keps Hex 1/4-20 Unc

**NOTE:** All component dimensions given in U.S. inches  
1 inch = 25.4 mm

# REPAIR PARTS

TRACTOR- -MODEL NO. WZ1842RDHA

## MOWER LIFT

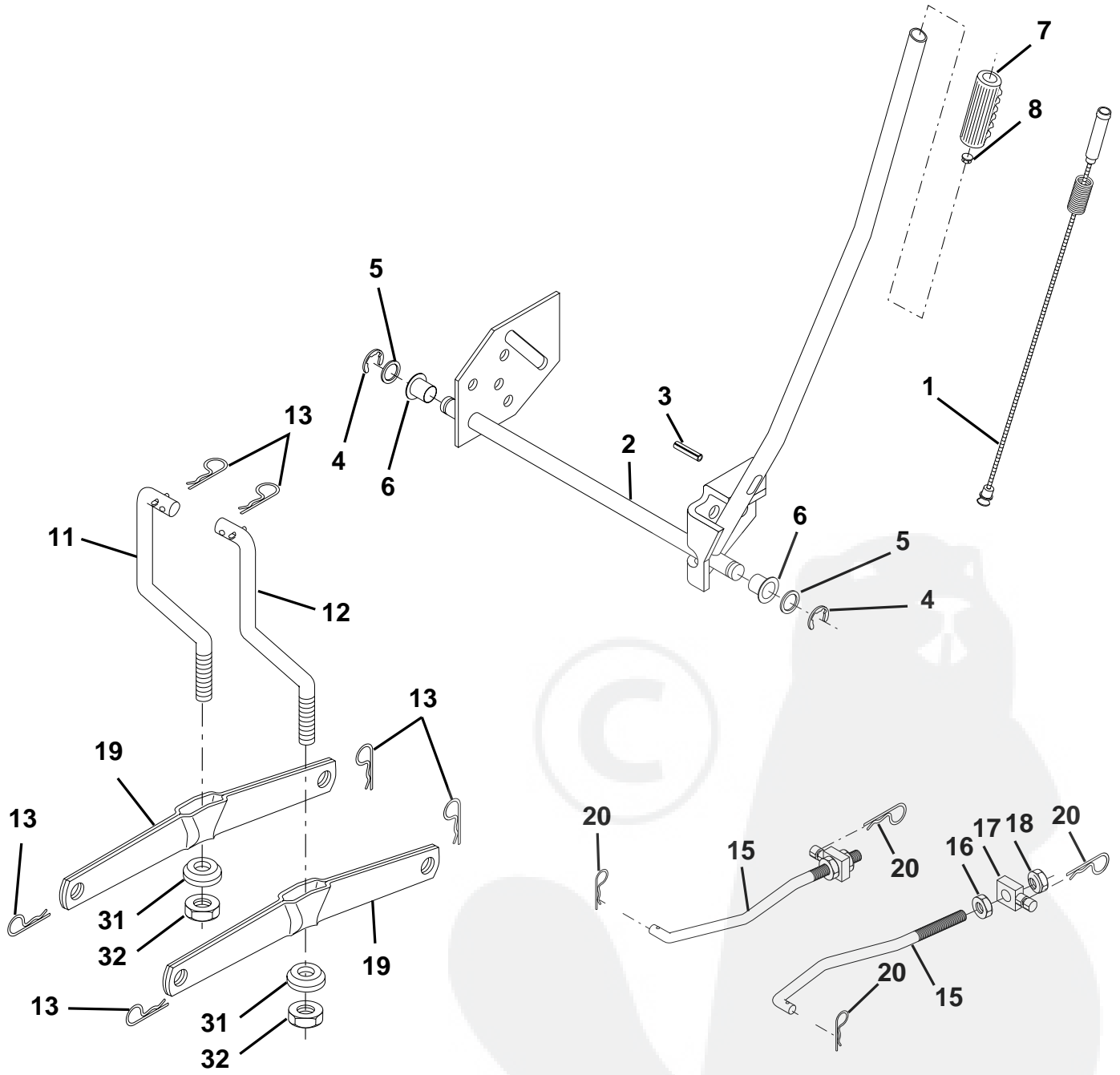



# REPAIR PARTS

## TRACTOR- -MODEL NO. WZ1842RDHA

### MOWER LIFT

KEY NO.	PART NO.	DESCRIPTION
1	159460	Washer Asm Inner Spring W/Plunger
2	159471	Shaft Asm. Lift
3	105767X	Pin Groove
4	12000002	E Ring #5133-62
5	19211621	Washer 21/32 x 1 x 21 Ga.
6	120183X	Bearing Nylon
7	109413X	Grip Handle
8	124526X	Button Plunger Black
11	165829	Link Asm Lift L.H.
12	165831	Link Asm Lift R.H.
13	4939M	Retainer Spring
15	173288	Link Front
16	73350800	Nut Jam Hex 1/2-13 Unc
17	130171	Trunnion Blk Zinc
18	73800800	Nut Lock w/Wsh 1/2-13 Unc
19	139868	Arm Suspension Mower
20	163552	Retainer Spring
31	169865	Bearing, Pvt. Lift.
32	73540600	Nut Crownlock 3/8-24

**NOTE:** All component dimensions given in U.S. inches  
1 inch = 25.4 mm





# REPAIR PARTS

## TRACTOR- -MODEL NO. WZ1842RDHA

### MOWER

KEY NO.	PART NO.	DESCRIPTION	KEY NO.	PART NO.	DESCRIPTION
1	169160	Housing Asm. Mower 107 CRD	39	72110622	Bolt Rdhd 3/8-16unc x 2-3/4
2	72140506	Bolt Rdhd Sqnk 5/16-18 Unc x 3/4	40	73680600	Nut Crownlock 3/8-16 Unc
3	165569	Bracket Asm. S-Bar Chass 107 CRD	41	73900600	Nut Lock Flg. 3/8-16
4	169167	Bracket Bar Sway Deck 107 CRD	44	169180	Cover Mandrel Lh 107 CRD
5	4939M	Retainer Spring	45	169179	Cover Mandrel Rh 107 CRD
6	165557	Bar Sway CRD	46	137729	Screw Thd Roll 1/4-20 x 5/8
8	850857	Bolt 3/8-24 x 1.25 Gr8 Patched	55	169849	Arm Idler 107 CRD
9	10030600	Washer Lock Hvy 3/8 Unplated	61	175159	Spring Tension Belt
10	140296	Washer Hard Blade Mower vented	67	106932X	Knob Rd 3/8-16 Plstdc Thds Blk
11	175450	Blade 3-1 Lh 107 CRD	68	169178	Hex-Belt 107 Mower
13	137645	Shaft Asm. W/Lower Bearing	69	165482	Shaft Asm W/Lwr Brg Rh Thd CRD
14	128774	Housing Mandrel Vented (Machd)	84	156085	Keeper Belt Idler
15	110485X	Bearing Ball Mandrel	116	137644	Bolt Shoulder
16	175451	Blade 3-1 Rh 107 CRD	117	133957	Wheel Gage Donut Wide
17	72140610	Bolt Carr. 3/8-16 x 1-1/4	118	73930600	Nut Centerlock 3/8-16 Unc
19	132827	Bolt Shoulder 5/16-18 Thd Form	119	19121414	Washer 3/8 x 7/8 x 14 Ga.
20	165484	Bolt 3/8-24 x 1.25 Gr8 Ptch Lhthd	124	72110612	Bolt Carr Sh 3/8-16 x 1-1/2 Gr5
21	73680500	Nut Crown Lock 5/16-18	130	72110506	Bolt Rdhdsqnk 5/16-18 Unc x 3/4
22	169165	Bracket Idler Sprt RR 107 CRD	131	165661	Chute Bagger CRD 92cm
23	169166	Bracket Idler Sprt RF 107 CRD	151	169670	Bracket Clutch Cable
24	169170	Bracket Suspension LF 107 CRD	152	176074	Cable Clutch CRD Service
25	169171	Bracket Suspension RF 107 CRD	153	169674	Washer Flat 3/8" Type B
26	165237	Brace Support Susp Frt CRD	154	169675	Spring Retainer
27	169172	Bracket Asm. Susp RR 107 CRD	155	169671	Spring Retention Lvr Clutch Cable
28	169168	Bracket Asm. Susp LR 107 CRD	156	169672	Spacer Clutch Cable
30	157722	Screw Thd Rolling Washer Head	157	169669	Rod Clutch Cable 3/8"
31	129963	Washer Spacer Mower Vented	158	17720410	Screw Hex Thd Cut 1/4-20 x 5/8
32	175707	Mandrel Pulleys	160	175160	Guide Belt
33	137266	Nut Flg Top Lock Cntr B 9/16	-	130794	Mandrel Asm Service
34	176291	Bracket Gauge Wheel Lf 107 CRD	-	165579	Mandrel Asm CRD Lh Threads SVC
35	176292	Bracket Gauge Wheel Rf 107 CRD	-	175842	Deck Mower Complete (Include Gauge Wheels Key Nos.34 and 35)
36	146763	Pulley Idler V-Groove Dim 4.25			
37	19131316	Washer 11/32 x 13/16 x 16 Ga			
38	169851	Spacer Hub Arm Idler			

**NOTE:** All component dimensions given in U.S. inches  
1 inch = 25.4 mm

# REPAIR PARTS

TRACTOR- -MODEL NO. WZ1842RDHA

BAGGER

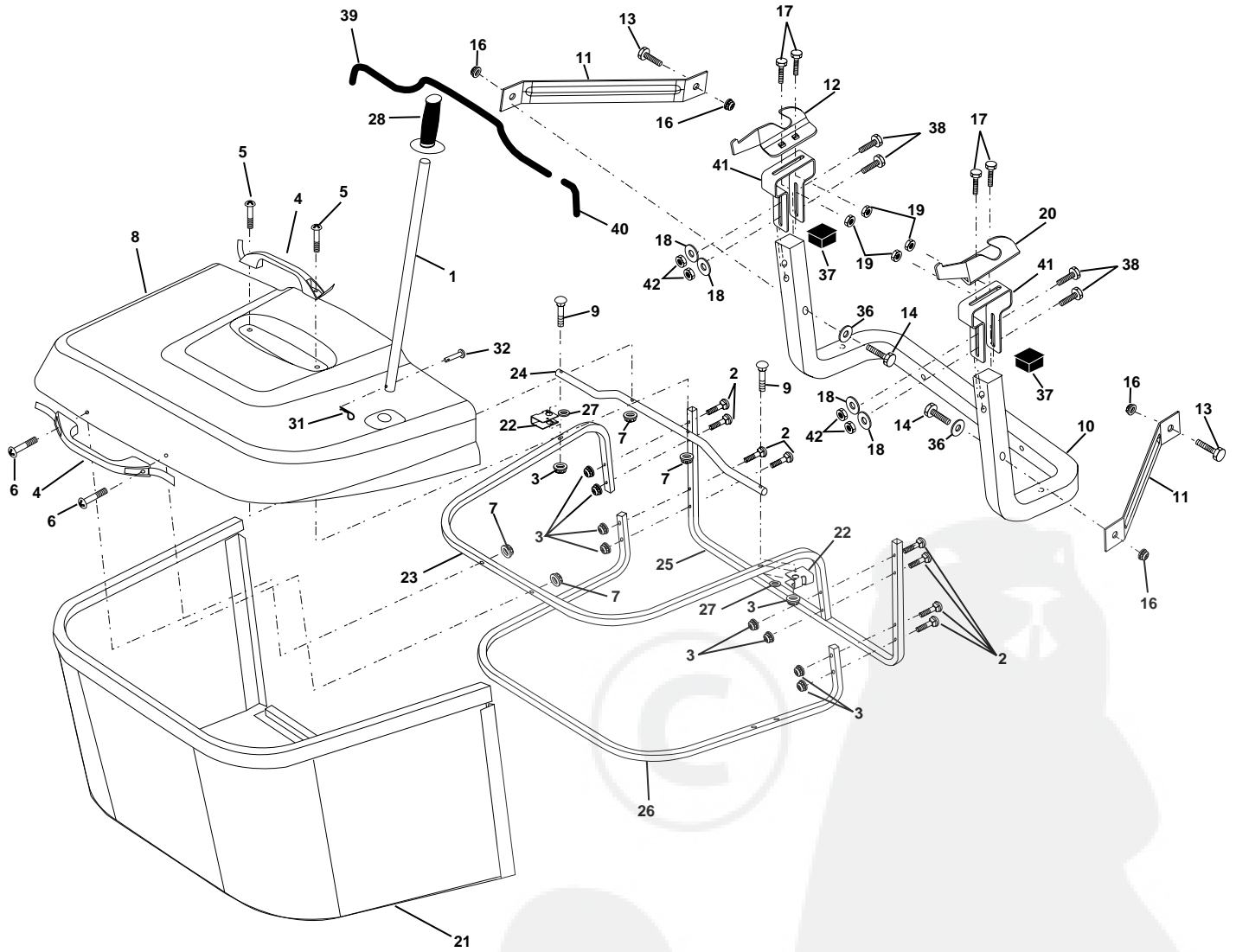

# REPAIR PARTS

## TRACTOR- -MODEL NO. WZ1842RDHA

### BAGGER

KEY NO.	PART NO.	DESCRIPTION
1	170690	Tube Handle Bagger CRD
2	72140416	Bolt Carriage 1/4-20 x 2.0 Gr.5
3	123976X	Nut Lock 1/4 Lge Flg Gr. 5 Zinc
4	169916	Handle Bagger w/Lvrs Blk CRD
5	74981024	Screw Pan Head #10-24 x 1.50 Blk
6	74981032	Screw Pan Hd
7	73401000	Nut Wiz Lock Hex Serr/Hd 10-24
8	165715X505	Cover Bagger Plastic CRD
9	72140418	Bolt Carriage 1/4-20 x 2.25d x Gr.5
10	169688	Tube Support Bagger CRD
11	165719	Bracket Support Upper Bag CRD
12	169685	Bracket Horizon Adj Bggr Lh CRD
13	72110606	Bolt Rdhd Sht Sqnk 3/8-16 x 3/4
14	74520640	Bolt Hex 3/8-16 x 2-1/2 Gr.5
16	73900600	Nut Lock Flg 3/8-16 Unc
17	72140506	Bolt Rdhd Sht Sqnk 5/16 -18 Unc x 3/4
18	19111216	Washer 11/32 x 3/4 x 16
19	73900500	Nut Lock Hex Flange 5/16-18
20	169684	Bracket Horiz Adj Bggr RH CRD
21	165780	Bag Asm CRD
22	165781	Bracket Side Bagger CRD
23	165782	Tube Upper Bagger CRD
24	165783	Tube Pivot Bagger CRD
25	165784	Tube Front Bagger CRD
26	165785	Tube Lower Bagger CRD
27	169692	Bushing Snap Bagger CRD
28	170696	Grip Handle
31	4497H	Retainer Spring 1" Zinc/Cad
32	126875X	Rivet Rd Hd Drilled 3/8 Dia
36	19132016	Washer 13/32 x 1-1/4 x 16 Ga.
37	175401	Plug Support
38	72010520	Bolt 5/16-18 x 2-1/2
39	169999	Seal 26" (Long)
40	170000	Seal 7" (Short)
41	169683	Bracket Vert Adj Bagger CRD
42	73800500	Nut Lock Hx w/Ins 5/16-18

**NOTE:** All component dimensions given in U.S. inches  
1 inch = 25.4 mm

---

# SERVICE NOTES

---



## LIMITED WARRANTY

The Manufacturer warrants to the original consumer purchaser that this product as manufactured is free from defects in materials and workmanship. For a period of one (1) year from date of purchase by the original consumer purchaser, we will repair or replace, at our option, without charge for parts or labor incurred in replacing parts, any part which we find to be defective due to materials or workmanship. This Warranty is subject to the following limitations and exclusions.

1. This warranty does not apply to the engine. Please contact your nearest dealer where they will send the machine to the engine manufacturer.
2. Transportation charges for the movement of any power equipment unit or attachment are the responsibility of the purchaser. Transportation charges for any parts submitted for replacement under this warranty must be paid by the purchaser unless such return is requested by your dealer.
3. Battery Warranty: On products equipped with a Battery, we will replace, without charge to you, any battery which we find to be defective in manufacture, during the first ninety (90) days of ownership. After ninety (90) days, we will exchange the Battery, charging you 1/12 of the price of a new Battery for each full month from the date of the original sale. Battery must be maintained in accordance with the instructions furnished.
4. The Warranty period for any products used for rental or commercial purposes is limited to 90 days from the date of original purchase.
5. This Warranty applies only to products which have been properly assembled, adjusted, operated, and maintained in accordance with the instructions furnished. This Warranty does not apply to any product which has been subjected to alteration, misuse, abuse, improper assembly or installation, delivery damage, or to normal wear of the product.
6. Exclusions: Excluded from this Warranty are belts, blades, blade adapters, normal wear, normal adjustments, standard hardware and normal maintenance.
7. In case of any problem within the boundaries of this warranty, contact the nearest department store, indicate the model number, serial number and the date of purchase of your machine. This warranty does not apply to accidental damages. All implicit warranties are limited to the same time frames. Or contact:

E.M. Services  
54 Rue Lambrechts  
92400 Courbevoie  
France  
Telephone: (1) 46678078  
Fax: (1) 46678095

THIS WARRANTY DOES NOT APPLY TO INCIDENTAL OR CONSEQUENTIAL DAMAGES. ANY IMPLIED WARRANTIES ARE LIMITED TO THE SAME TIME PERIODS STATED HEREIN.



**WIZARD**