

Spare Parts List

2006-03



MS-251.4

IMPORTANT! - To assure product SAFETY and RELIABILITY, repairs, maintenance or adjustments should be performed by DOLMAR Service Centers, or other qualified service organisations. Always use DOLMAR replacement parts.

DOLMAR



A member of the *Makita* Group

995 700 257 (GB)

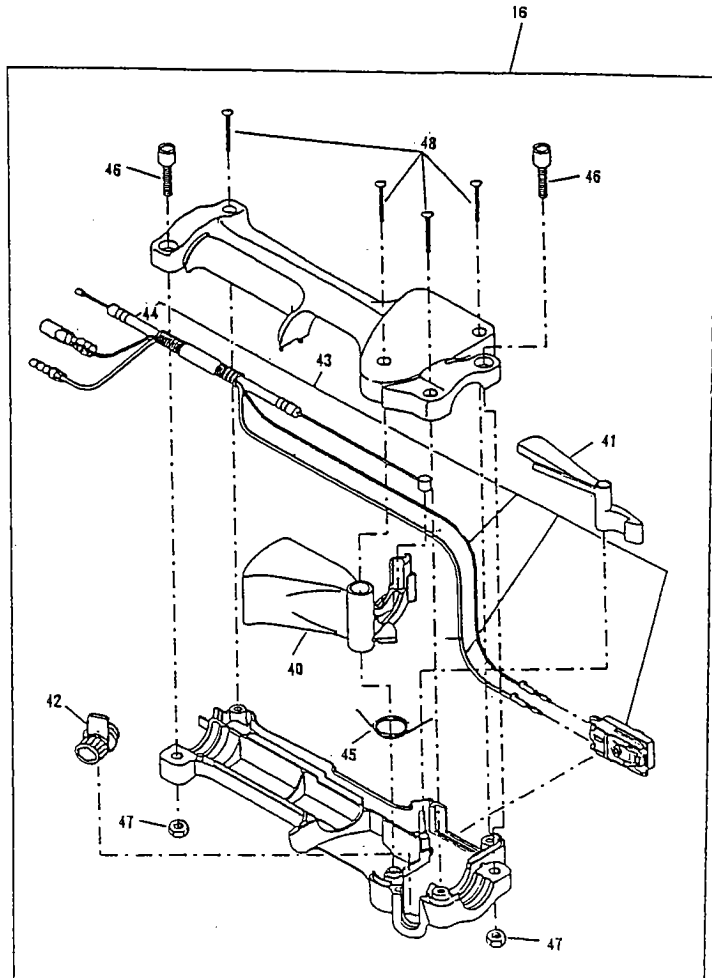
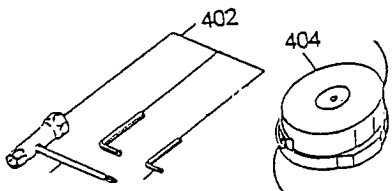
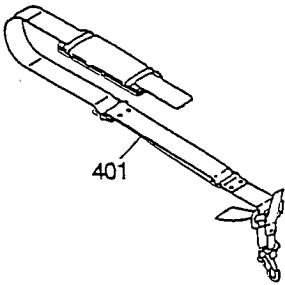
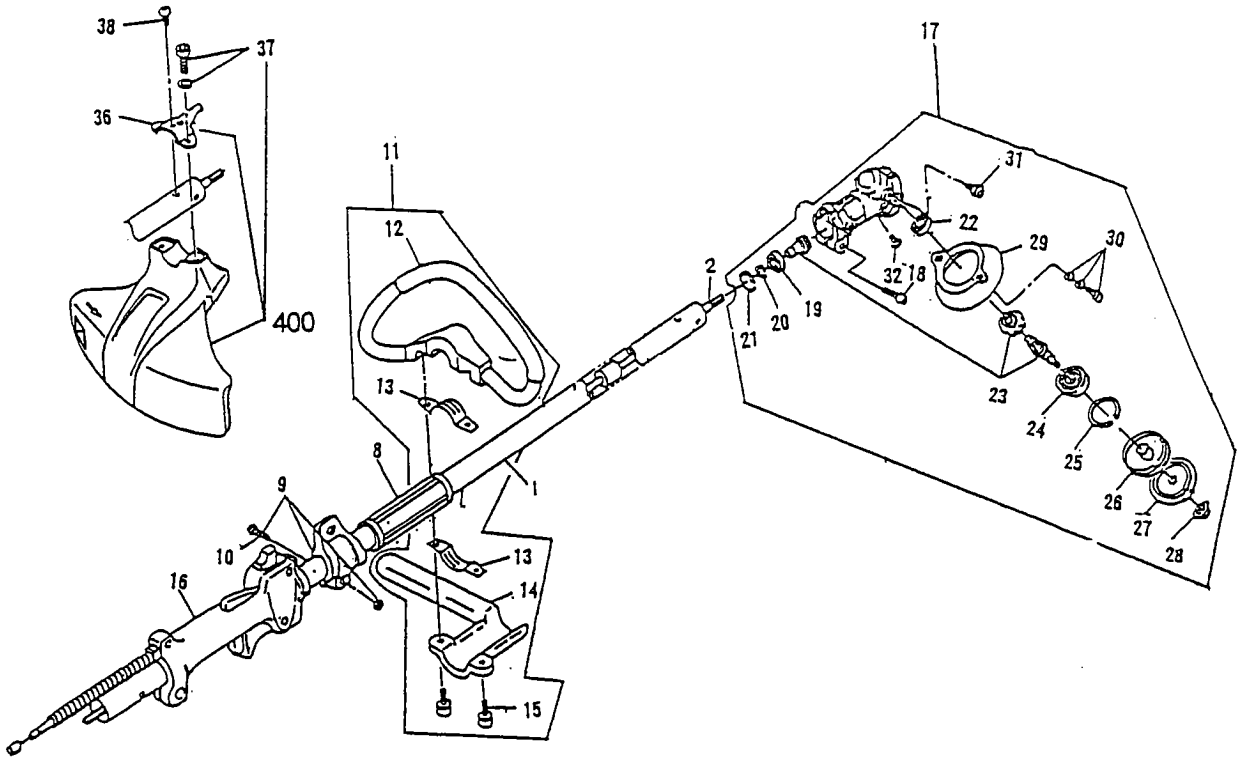

MS-251.4



Page	Pos.	MS-251.4	Part No.	Notes	Description	Specifications
1	1	1	367 100 300		SHAFT PIPE COMPLETE	
1	2	1	367 150 630		SHAFT	
1	8	1	383 150 150		SPACER	
1	9	1	367 401 900		HANGER ASS'Y	INC. 10
1	10	1	367 360 520		SCREW & WASHER ASS'Y	
1	11	1	374 401 400		HANDLE COMPLETE	INC. 12-15
1	12	1	367 400 401		LOOP HANDLE	
1	13	2	367 401 401		GUARD STAY	
1	14	1	367 400 402		LOOP HANDLE COVER	
1	15	2	367 400 404		SOCKET HEAD BOLT	M6X18
1	16	1	374 500 300		CONTROL LEVER ASS'Y	INC. 40-48
1	17	1	377 301 700		GEAR CASE ASS'Y	INC. 18-32
1	18	1	367 905 989		SOCKET HEAD BOLT	M5X25
1	19	1	381 250 030		BALL BEARING	#609ZZ
1	20	1	381 150 800		OUTER SNAP RING	
1	21	1	381 142 400		INNER SNAP RING	
1	22	1	367 006 999		BALL BEARING	626ZZ
1	23	1	367 302 100		CUTTER SHAFT SET	
1	24	1	388 010 991		BALL BEARING	6000DDU
1	25	1	381 142 600		INNER SNAP RING	
1	26	1	367 850 160		RECEIVE WASHER	
1	27	1	382 800 300		CLAMP COMPL. WASHER	
1	28	1	367 850 500		NUT	
1	29	1	381 850 020		GUARD	
1	30	2	381 905 978		SOCKET HEAD BOLT	M5X12
1	31	1	367 301 101		OIL BOLT	M6X9
1	32	1	367 310 506		PAN HEAD SCREW	
1	36	1	381 850 030		PROTECTOR CLAMP	
1	37	2	381 170 630		BOLT	M6X30
1	38	1	381 005 994		TAPPING SCREW	
1	40	1	374 500 603		LEVER	
1	41	1	367 502 306		LEVER	
1	42	1	367 502 305		ADJUST COMPLETE	
1	43	1	374 500 301		WIRE SET	INC. 44
1	44	1	374 500 302		WIRE COMPLETE	
1	45	1	367 500 605		SPRING	
1	46	2	374 905 972		SOCKET HEAD BOLT	M5X20
1	47	2	374 501 116		NUT	
1	48	4	367 500 606		TAPPING SCREW	M4X20
1	400	1	381 800 800		PROTECTOR ASS'Y	INC. 36,37
1	401	1	367 700 300		BAND ASS'Y	
1	402	1	382 900 600		TOOL SET	
1	403	1	367 210 500		OIL BOTTLE	
1	404	1	374 601 430		BUMP & FEED	BF4L

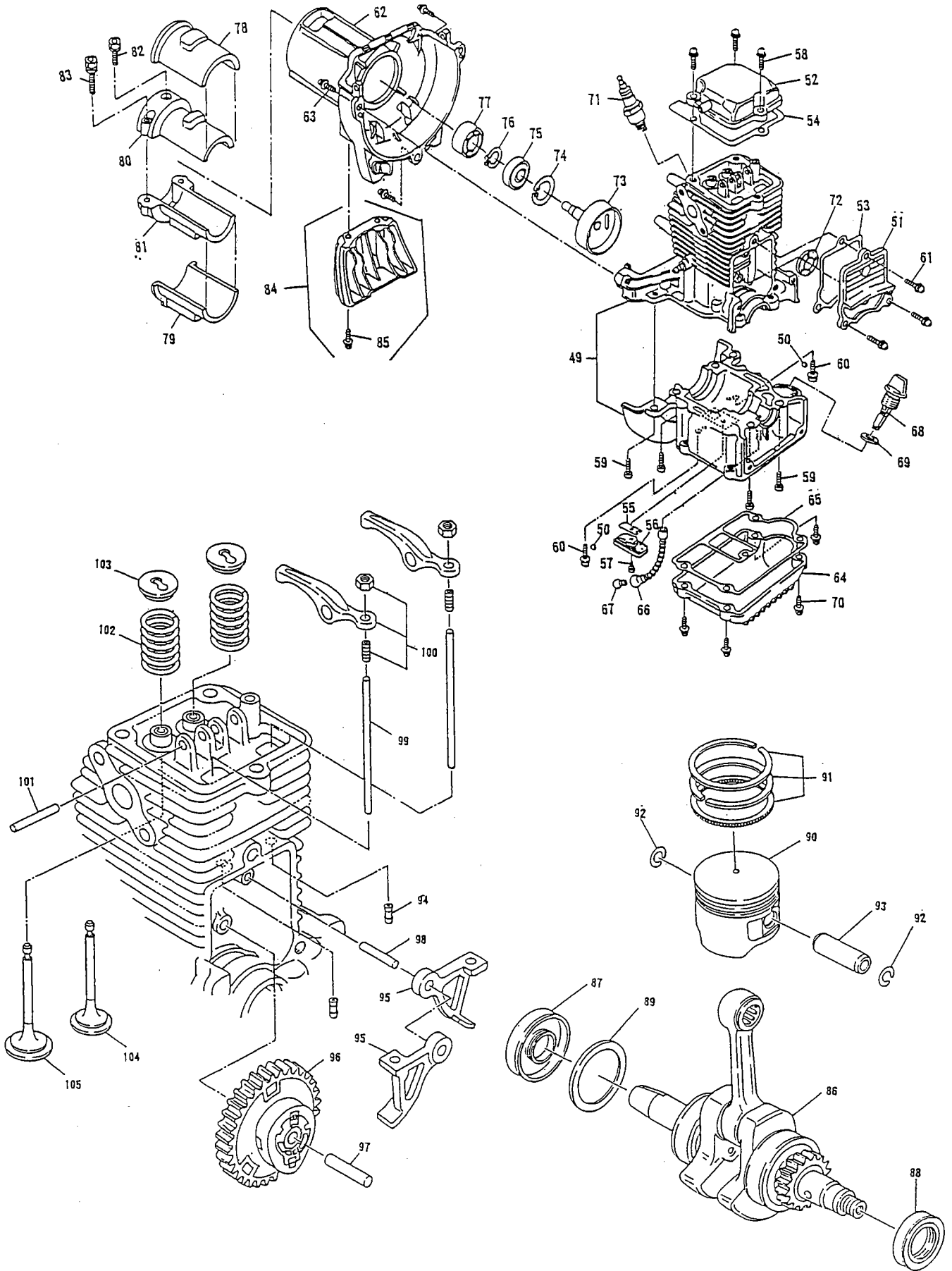

MS-251.4



Page	Pos.	MS-251.4	Part No.	Notes	Description	Specifications
2	49	1	367 100 500		CYLINDER BLOCK SET	
2	50	2	388 150 120		BALL	
2	51	1	383 150 050		CAMGEAR COVER	
2	52	1	367 100 400		ROCKER COVER COMPLETE	
2	53	1	367 150 070		CAMGEAR COVER GASKET	
2	54	1	367 150 080		ROCKER COVER GASKET	
2	55	1	367 150 100		LEAD VALVE	
2	56	1	367 150 110		RETAINER PLATE	
2	57	1	367 904 998		SOCKET HEAD BOLT	M4X10
2	58	3	367 360 516		SCREW ASS'Y	M5X16 (W,SW)
2	59	6	367 905 951		SOCKET HEAD BOLT	M5X14
2	60	2	367 905 950		SOCKET HEAD BOLT	M5X30 (W)
2	61	3	367 360 514		SCREW ASS'Y	M5X14
2	62	1	388 150 020		CLUTCH CASE	
2	63	3	367 360 516		SCREW ASS'Y	M5X16 (W,SW)
2	64	1	367 650 000		OIL CASE	
2	65	1	367 650 010		CASE GASKET	
2	66	1	367 650 020		OIL TUBE	
2	67	1	367 650 030		OIL WEIGHT	
2	68	1	367 650 060		OIL GAUGE	
2	69	1	367 316 002		GASKET	16DX23X1.2T
2	70	4	381 360 518		SCREW ASS'Y	
2	71	1	367 010 995		SPARK PLUG	CMR6A
2	72	1	367 350 380		WASHER	
2	73	1	388 200 300		CLUTCH DRUM COMPLETE	
2	74	1	382 143 200		INNER SNAP RING	
2	75	1	382 012 995		BALL BEARING	#6201DD/#6201 2RU
2	76	1	382 151 200		OUTER SNAP RING	
2	77	1	388 150 030		SPACER	
2	78	1	388 150 040		PIPE DAMPER 1	
2	79	1	388 150 050		PIPE DAMPER 2	
2	80	1	388 150 060		PIPE BRACKET 1	
2	81	1	388 150 070		PIPE BRACKET 2	
2	82	1	367 905 990		SOCKET HEAD BOLT	M5X12
2	83	2	381 905 995		SOCKET HEAD BOLT	M5X18
2	84	1	381 900 200		STAND SET	INC. 85
2	85	2	381 005 948		SCREW ASS'Y	M5X14
2	86	1	367 200 300		CRANK SHAFT ASS'Y	
2	87	1	367 012 996		OIL SEAL (L)	
2	88	1	367 010 997		OIL SEAL (S)	
2	89	1	381 150 050		CLIP	
2	90	1	367 250 090		PISTON	
2	91	1	367 200 400		PISTON RING SET	
2	92	2	388 508 997		CLIP	
2	93	1	388 250 260		PISTON PIN	
2	94	2	367 150 140		SPACER	
2	95	2	367 350 000		CAM LIFTER	
2	96	1	374 300 700		CAM GEAR ASS'Y	
2	97	1	367 350 050		CAM GEAR SHAFT	
2	98	1	367 350 060		CAM LIFTER SHAFT	
2	99	2	367 350 070		PUSH ROD	
2	100	2	367 300 200		ROCKER ARM ASS'Y	
2	101	1	367 350 110		ROCKER SHAFT	
2	102	2	367 350 120		VALVE SPRING	
2	103	3	367 350 130		SPRING RETAINER	
2	104	1	367 350 140		EXHAUST VALVE	
2	105	1	367 350 150		INTAKE VALVE	

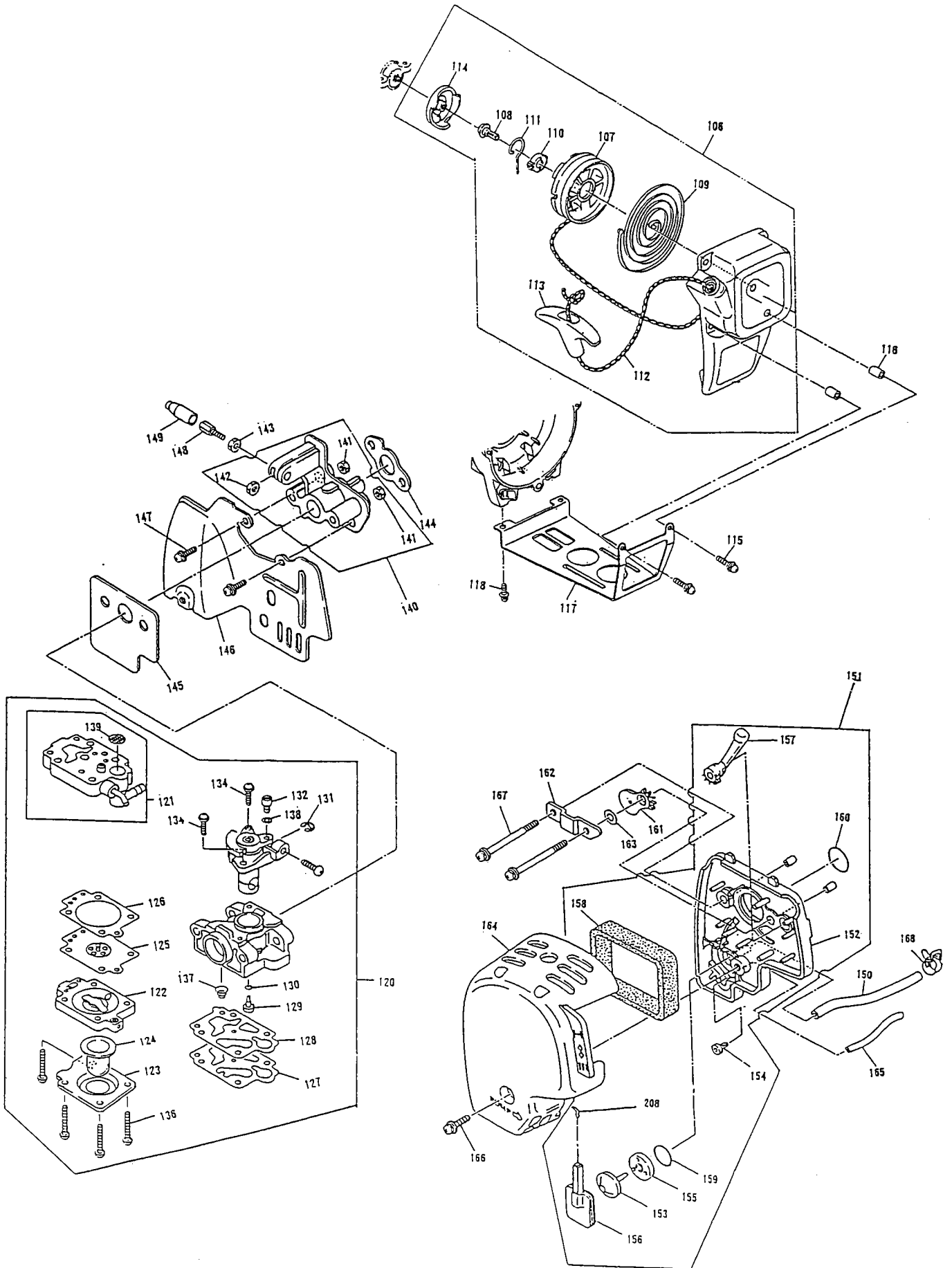

MS-251.4



Page	Pos.	MS-251.4	Part No.	Notes	Description	Specifications
3	106	1	367 500 100		STARTER COVER ASS'Y	INC. 107-114
3	107	1	367 500 103		REEL	
3	108	1	367 500 206		SET SCREW	
3	109	1	381 500 203		SPIRAL SPRING	
3	110	1	367 500 211		COLLAR	
3	111	1	367 500 210		SWING ARM	
3	112	1	367 500 105		STARTER ROPE	
3	113	1	388 500 402		HANDLE	
3	114	1	367 550 000		PULLEY	
3	115	2	367 360 425		SCREW ASS'Y	M4X25
3	116	2	367 004 994		SPACER	
3	117	1	367 950 080		TANK GUARD	
3	118	2	367 360 510		SCREW ASSEMBLY	
3	120	1	374 600 800		CARBURETOR	INC. 121-132,134,136-138
3	121	1	374 600 206		PUMP BODY ASS'Y	INC. 139
3	122	1	374 604 614		AIR PURGE BODY ASS'Y	
3	123	1	374 604 605		PRIMER PUMP COVER	
3	124	1	381 600 115		PRIMER PUMP	
3	125	1	367 600 801		METERING DIAPHRAGM ASS'Y	
3	126	1	381 604 604		METERING DIAPHRAGM GASKET	
3	127	1	381 600 104		PUMP DIAPHRAGM	
3	128	1	367 600 204		PUMP GASKET	
3	129	1	374 600 203		JET	
3	130	1	381 600 101		O RING	
3	131	1	381 600 512		RING	
3	132	1	381 601 804		SWIVEL	
3	134	2	388 600 803		PAN HEAD SCREW	
3	136	4	381 604 601		PUMP COVER SCREW	
3	137	1	367 600 202		PUMP SPRING	
3	138	1	367 600 503		WASHER	
3	139	1	381 600 401		INLET SCREEN	
3	140	1	367 300 500		INSULATOR COMPLETE	INC. 141,142
3	141	2	367 005 998		NUT	M5
3	142	1	377 270 600		NUT	M6
3	143	1	377 270 600		NUT	M6
3	144	1	367 350 180		INSULATOR GASKET	
3	145	1	367 350 190		CARBURETOR GASKET	
3	146	1	367 350 200		CARBURETOR INSULATOR	
3	147	2	381 360 518		SCREW ASS'Y	
3	148	1	367 906 997		ADJUST SCREW	
3	149	1	367 600 415		CAP	
3	150	1	367 150 090		BREATHER PIPE	
3	151	1	957 300 100		CLEANER PLATE ASS'Y	INC. 152-160
3	152	1	381 300 600		AIR CLEANER PLATE COMPLETE	
3	153	1	367 650 070		CHECK VALVE	
3	154	1	367 350 240		CHECK VALVE (1)	
3	155	1	367 350 250		CHECK VALVE PLATE	
3	156	1	367 350 330		SEPARATOR PLATE	
3	157	1	367 350 220		CHOKE LEVER	
3	158	1	367 350 320		AIR CLEANER ELEMENT	
3	159	1	367 013 997		O RING	P14
3	160	1	367 015 999		O RING	P15
3	161	1	367 350 230		CHOKE PLATE	
3	162	1	367 350 260		PLATE	
3	163	1	381 306 999		GASKET	
3	164	1	367 350 270		AIR CLEANER COVER	
3	165	1	367 350 300		PIPE	
3	166	1	381 005 948		SCREW ASS'Y	M5X14
3	167	2	367 350 310		SCREW	M5X68 (W,SW SUS)
3	168	1	382 108 001		HOSE CLAMP	
3	208	1	374 350 390		PIPE	

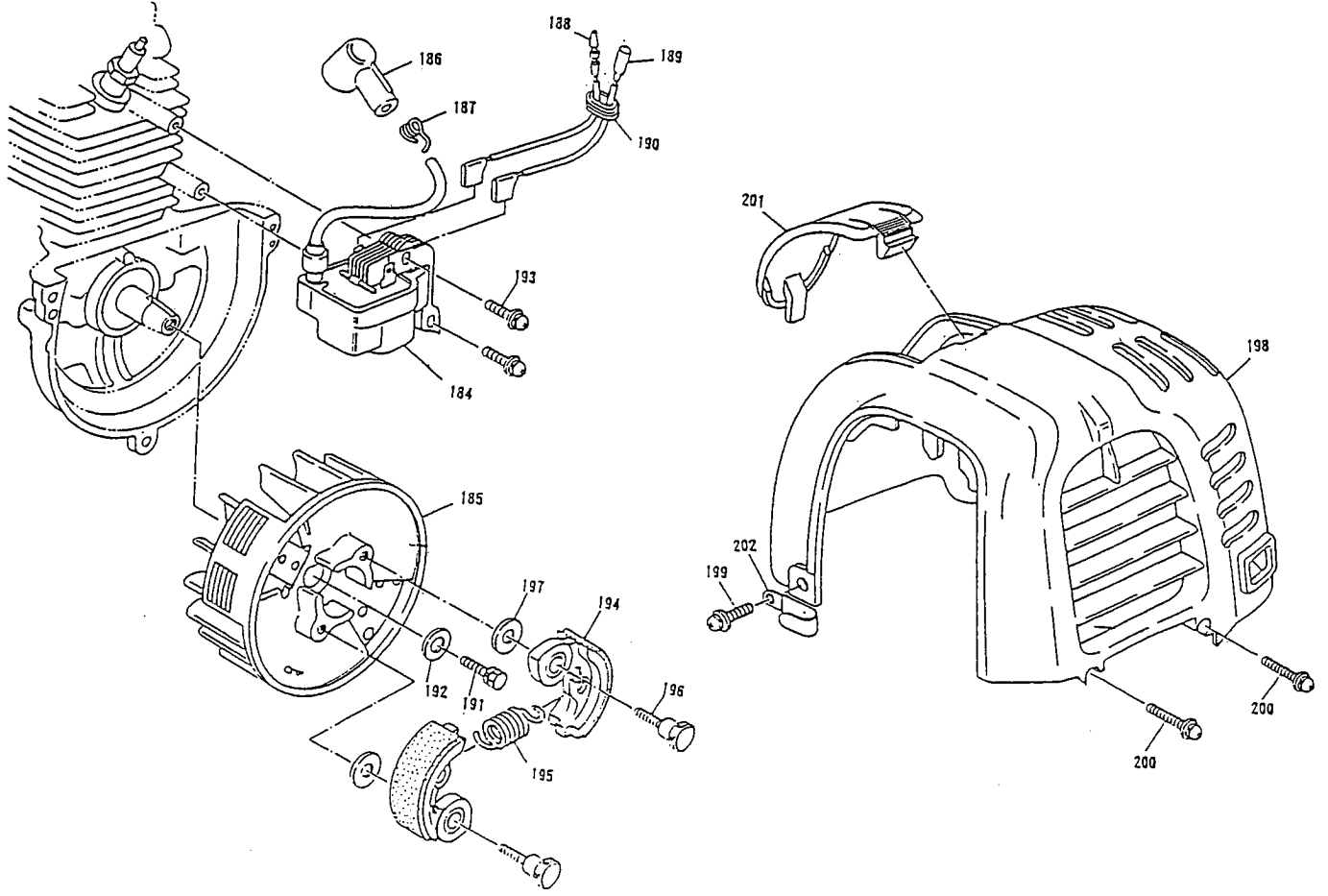
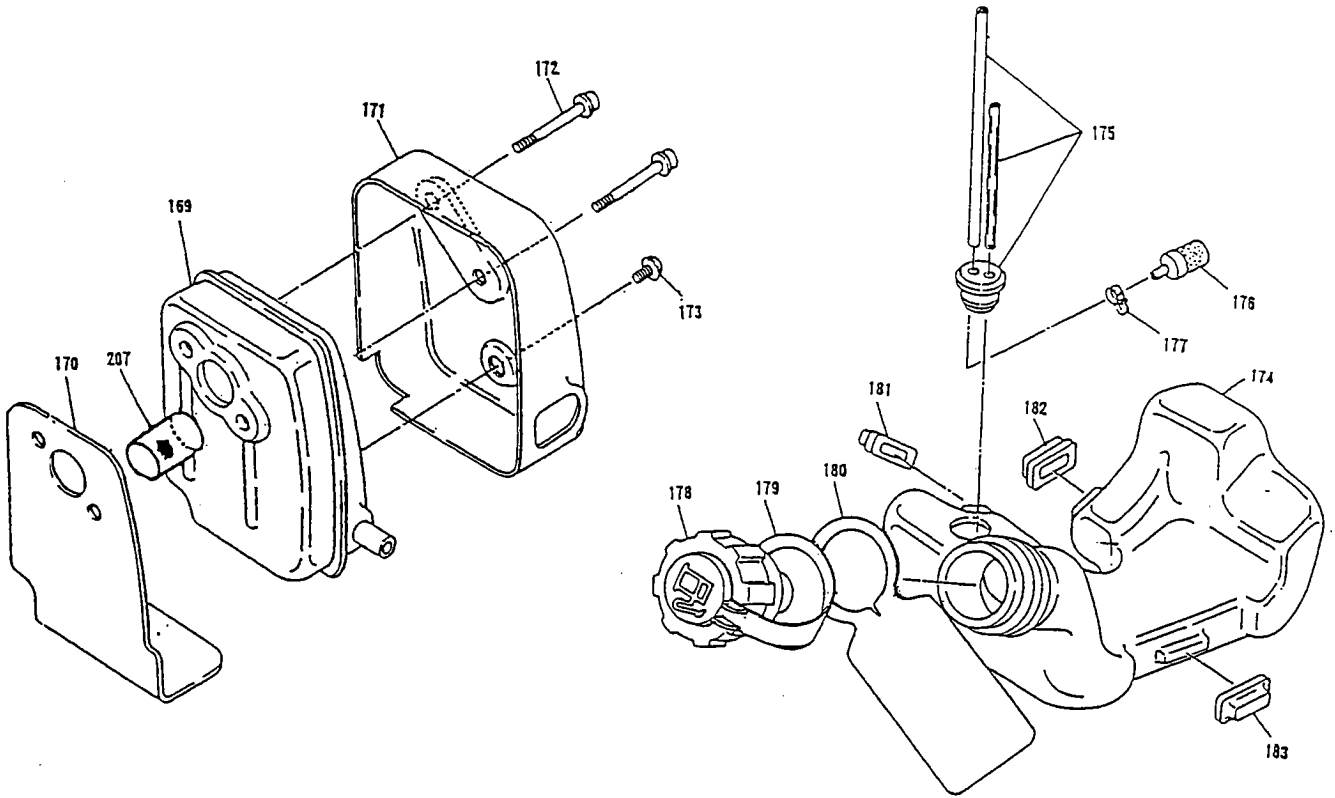

MS-251.4



Page	Pos.	MS-251.4	Part No.	Notes	Description	Specifications
4	169	1	367 300 100		EXHAUST MUFFLER	
4	170	1	367 350 160		MUFFLER GASKET	
4	171	1	367 350 340		MUFFLER COVER	
4	172	2	367 905 952		SOCKET HEAD BOLT	M5X40
4	173	1	367 005 996		SCREW	M5X6
4	174	1	367 650 040		FUEL TANK	
4	175	1	367 600 300		TUBE	
4	176	1	382 650 390		FILTER	
4	177	1	381 105 999		HOSE CLAMP	
4	178	1	367 600 600		FUEL TANK CAP	
4	179	1	367 600 500		STRAP	
4	180	1	367 950 150		STRAP	
4	181	1	381 650 020		PLATE	
4	182	1	381 650 030		PLATE	
4	183	1	388 650 030		DAMPER	
4	184	1	367 700 101		IGNITION COIL	
4	185	1	367 700 102		FLYWHEEL	
4	186	1	367 750 010		PLUG CAP	
4	187	1	377 400 993		PLUG CAP SPRING	
4	188	1	388 700 300		WIRE COMPLETE	
4	189	1	367 701 800		WIRE COMPLETE	
4	190	1	374 750 030		GROMMET	
4	191	1	381 130 616		BOLT ASS'Y	
4	192	1	381 120 600		WASHER	
4	193	2	367 004 992		SCREW ASS'Y	M4X20
4	194	2	367 850 000		CLUTCH SHOE	
4	195	1	367 850 010		SPRING	
4	196	2	367 850 020		CLUTCH BOLT	
4	197	2	367 850 030		WASHER	
4	198	1	367 550 090		CYLINDER COVER	
4	199	2	367 360 510		SCREW ASSEMBLY	
4	200	2	367 360 416		SCREW	M4X16(W,SW)
4	201	1	367 750 000		PLUG COVER	
4	202	1	374 605 998		CLAMP	
4	207	1	388 300 801		SPARK ARRESTER	

- 1 Pipe, handle, protector, gear case, control lever, accessories
- 2 Crankcase, cylinder, valves, clutch case
- 3 Starter, carburetor, air cleaner
- 4 Fuel tank, exhaust muffler, ignition, clutch

	Key to symbols
⇒ 1999999 2000000 ⇒ 2003.04 ⇒ TI 2003/07 Acc. = { m Corr.	Production to serial number New part from serial number New part from Year / Month See Technical Information Year / No. Accessories (not included in the delivery inventory) No standard execution, may be used Contains item number Sold by the meter Error correction
	Specifications subject to change without notice