

Ersatzteilliste
Spare Parts List
Liste de pièces détachées
Lista de piezas de repuesto

2002-11

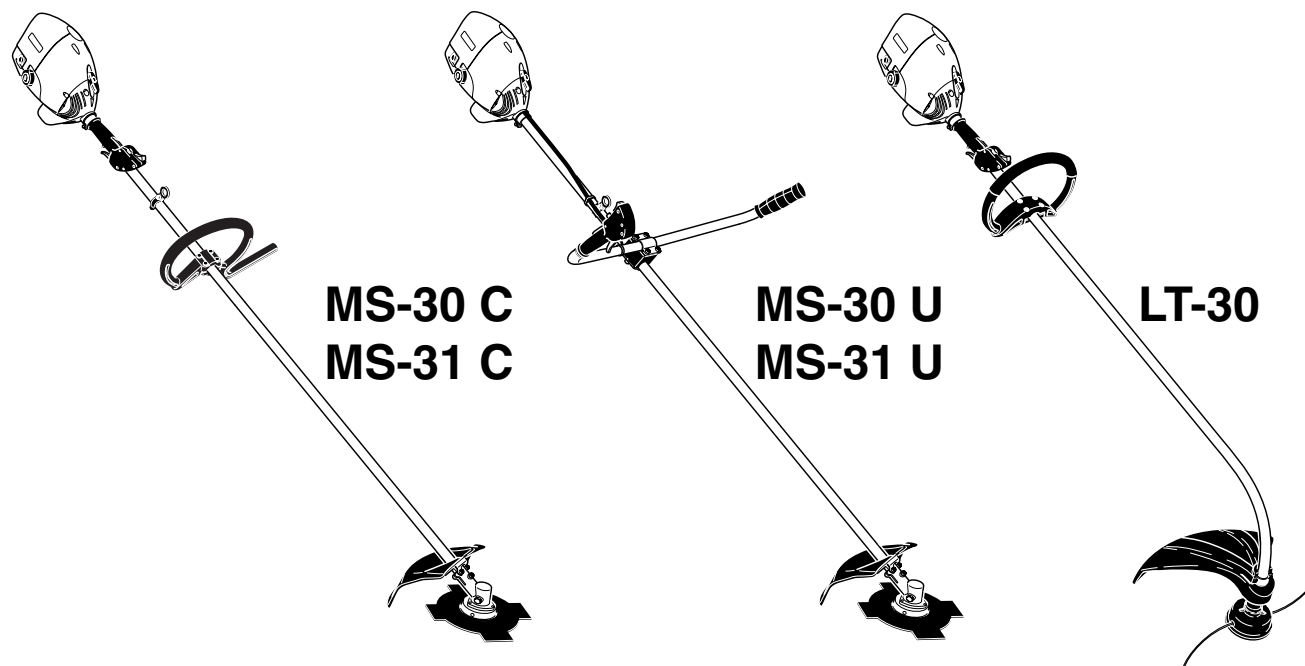

DOLMAR



995 700 179 (D, GB, F, E)

MS-30
MS-31
LT-30

1

Luftfilter, Tank, Motorhaube
Air filter, tank, motor hood
Filtre à air, réservoir, capot du moteur
Filtro de aire, depósito, carter de motor

DOLMAR
■■■■■■■■■■

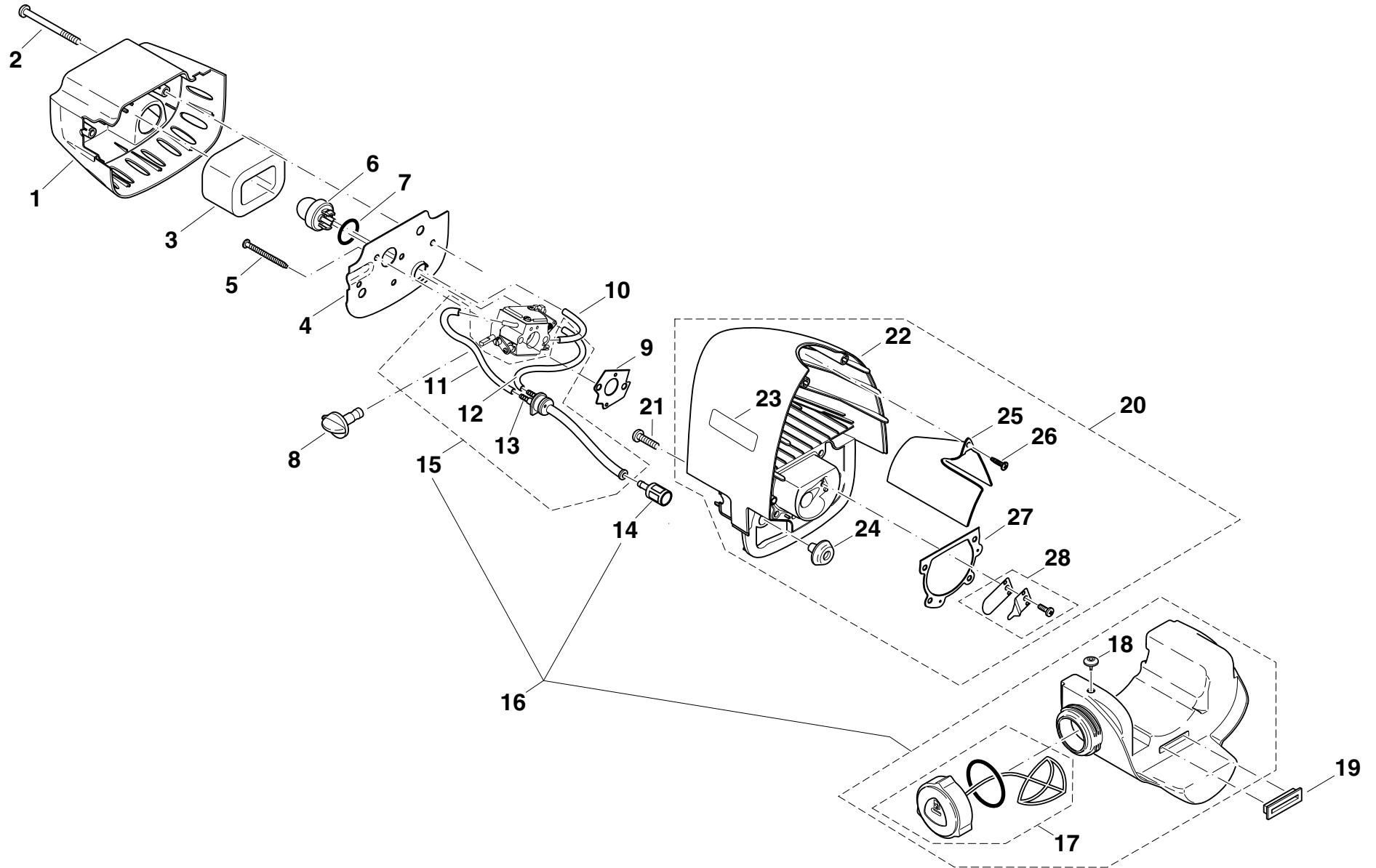

MS-30, MS-31, LT-30



Seite / Page	Pos.	MS-30 U	MS-31 U	MS-30 C	MS-31 C	LT-30	Teil-Nr. Part No. No. de pièce No. de pieza	Hinweise Notes Renseign. Nota	Bezeichnung	Spezifikation Specification	Description	Désignation	Denominación
1	1	1	1	1	1	1	369 118 321		Luftfilterdeckel, schwarz		Cover, black	Couvercle, noir	Tapa, negro
1	2	2	2	2	2	2	904 905 605		Kreuzschlitz-Schraube	M5x60	Screw	Vis	Tornillo
1	3	1	1	1	1	1	369 173 050		Luftfilter		Air filter	Filtre à air	Filtro de aire
1	4	1	1	1	1	1	369 173 030		Grundplatte		Plate	Plaque de tôle	Plancha de chapa
1	5	2	2	2	2	2	913 750 455		Innenstern-Schlitz-Schraube	5x45	Screw	Vis	Tornillo
1	6	1	1	1	1	1	369 155 010		Kraftstoffpumpe "Primer"		Primer	Pompe à carburant	Bomba de combustible
1	7	1	1	1	1	1	963 225 020		O-Ring	ø25x2	O-ring	Joint torique	Anillo de guarnición
1	8	1	1	1	1	1	369 155 020		Chokehebel		Choke lever	Levier clapet d' aire	Palanca valvula aire
1	9	1	1	1	1	1	965 527 110		Dichtung für Vergaser		Gasket	Joint	Junta
1	10	m*	m*	m*	m*	m*	965 452 060		Kraftstoffschlauch	37 mm	Tube	Gaine	Tubo
1	11	m*	m*	m*	m*	m*	965 452 060	130000 ⇒	Kraftstoffschlauch	86 mm	Tube	Gaine	Tubo
1	12	m*	m*	m*	m*	m*	965 452 060	130000 ⇒	Kraftstoffschlauch	100 mm	Tube	Gaine	Tubo
1	13	2	2	2	2	2	001 131 030		Schlauchnippel		Nipple	Nipple	Niple
1	14	1	1	1	1	1	963 601 380		Kraftstofffilter		Suction head	Tête d' aspiration	Cabeza de aspiración
1	15	1	1	1	1	1	965 404 666		Kraftstoffleitung kpl.		Fuel line cpl.	Conduite carburant cpl.	Conducto combustible cpl.
1	16	1	1	1	1	1	369 114 300		Tank kpl.		Tank assy.	Réservoir cpl.	Depósito cpl.
1	17	1	1	1	1	1	010 114 049		Tankverschluß kpl.		Tank plug cpl.	Bouchon réservoir cpl.	Cierre depósito cpl.
1	18	1	1	1	1	1	965 404 220		Gummiventil		Valve	Soupape	Válvula
1	19	1	1	1	1	1	965 404 941		Gummipuffer		Rubber buffer	Butoir caoutchouc	Tope de goma
1	20	1	1	1	1	1	369 118 101	98299 ⇒	Motorhaube kpl.		Motor hood cpl.	Capot du moteur cpl.	Carter de motor cpl.
1	21	4	4	4	4	4	913 205 255		Innenstern-Schlitz-Schraube	5x25	Screw	Vis	Tornillo
1	22	1	1	1	1	1	369 118 050	⇒ 98298	Motorhaube mit Bohrung		Motor hood	Capot du moteur	Carter de motor
1	22	1	1	1	1	1	369 118 052	98299 ⇒	Motorhaube mit Bohrung		Motor hood	Capot du moteur	Carter de motor
1	23	1	1	1	1	1	980 114 288		Schild		Label	Plaque	Calcomania
1	24	2	2	2	2	2	965 404 931	⇒ 98298	Gummipuffer, konisch		Rubber buffer	Butoir caoutchouc	Tope de goma
1	24	2	2	2	2	2	965 404 961	98299 ⇒	Gummipuffer, konisch		Rubber buffer	Butoir caoutchouc	Tope de goma
1	25	1	1	1	1	1	369 118 040	⇒ 98298	Wärmeschott		Insulation	Isolation	Aislamiento
1	25	1	1	1	1	1	369 118 041	98299 ⇒	Wärmeschott		Insulation	Isolation	Aislamiento
1	26	1	1	1	1	1	913 540 185	98299 ⇒	Kreuzschlitz-Schraube	4x18	Screw	Vis	Tornillo
1	27	1	1	1	1	1	965 527 100		Kurbelgehäusedichtung		Gasket	Joint	Junta
1	28	1	1	1	1	1	957 179 010		Einlaßmembran kpl.		Reedvalve cpl.	Soupape cpl.	Válvula cpl.

MS-30, MS-31, LT-30



Seite / Page	Pos.	MS-30 U	MS-31 U	MS-30 C	MS-31 C	LT-30	Teil-Nr. Part No. No. de pièce No. de pieza	Hinweise Notes Renseign. Nota	Bezeichnung	Spezifikation Specification	Description	Désignation	Denominación
2	30	1	1				369 100 702		Motor kpl. mit Gasgriff		Engine cpl. incl. operating lever	Moteur cpl. incl. levier de réglage	Motor cpl. incl. botón de mando
2	31			1	1	1	369 100 701		Motor kpl. mit Gasgriff		Engine cpl. incl. operating lever	Moteur cpl. incl. levier de réglage	Motor cpl. incl. botón de mando
2	32	1		1		1	369 131 100		Zylinder mit Schalldämpfer kpl.		Cylinder with muffler cpl.	Cylindre a. pot d' échappement cpl.	Cilíndro con silencioso cpl.
2	33	1	1	1	1	1	369 131 110	USA, CDN, AUS, NZ	Zylinder mit Schalldämpfer kpl.		Cylinder with muffler 369.174.110 cpl.	Cylindre a. pot d' échappement cpl.	Cilíndro con silencioso cpl.
2	34	1	1	1	1	1	369 174 200	USA, CDN, AUS, NZ	Funkenschutzsieb kpl.		Spark arrester screen cpl.	Tamis anti bruit cpl.	Tamiz protector chispas cpl.
2	35	2	2	2	2	2	913 205 255		Innenstern-Schlitz-Schraube	5x25	Screw	Vis	Tornillo
2	36	1	1	1	1	1	369 132 021		Kolben mit Pleuel kpl.	ø 37 mm	Piston with connecting rod cpl.	Piston avec bielle cpl.	Piston con biela cpl.
2	37	1	1	1	1	1	021 132 030		Kolbenring	ø 37 mm	Piston ring	Segment de piston	Segment de pistón
2	38	1	1	1	1	1	369 111 040		Kurbelgehäuse Umbausatz		Crankcase, modification set	Carter-vilebrequin, jeu de modification	Carter cigüeñal, juego de reconstrucción
2	39	1	1	1	1	1	965 527 120	117556 →	Dichtung		Gasket	Joint	Junta
2	40	1	1	1	1	1	965 527 081	→ 117555	Dichtung		Gasket	Joint	Junta
2	41	2	2	2	2	2	928 025 005		Tellerfeder		Cup spring	Ressort à disques	Resorte de disco
2	42	1	1	1	1	1	369 141 110	4712 →	Polrad mit Anwerfklinke kpl.		Flywheel with starter ratchet cpl.	Roue polaire avec cliquet cpl.	Volante encendido con trinquete arranque cpl.
2	43	1	1	1	1	1	369 141 102	→ 4711	Polrad mit Anwerfklinke kpl.		Flywheel with starter ratchet cpl.	Roue polaire avec cliquet cpl.	Volante encendido con trinquete arranque cpl.
2	44	1	1	1	1	1	939 615 260	→ 4711	Scheibenfeder		Key	Clavette	Chaveta
2	45	1	1	1	1	1	369 129 010		Distanzhülse		Spacer	Douille de distance	Casquillo separador
2	46	1	1	1	1	1	965 605 411		Flachstecker		Plug	Fiche	Ficha de contacto
2	47	1	1	1	1	1	369 143 010		Zünder kpl.		Ignition coil cpl.	Bobine d' allumage cpl.	Bobina encendido cpl.
2	48	1	1	1	1	1	965 603 021		Zündkerze		Spark plug	Bougie	Bujía
2	49	1	1	1	1	1	970 311 450		Kurzschlußkabel		Short-circuit cable	Câble court-circuit	Cable corto-circuito
2	50	2	2	2	2	2	913 204 255		Innenstern-Schlitz-Schraube	4x25	Screw	Vis	Tornillo

MS-30
MS-31
LT-30

3

Starter, Kupplung
Starter, clutch
Dispositif de démarrage, embrayage
Dispositivo de arranque, embrague

DOLMAR
■■■■■■■■■■

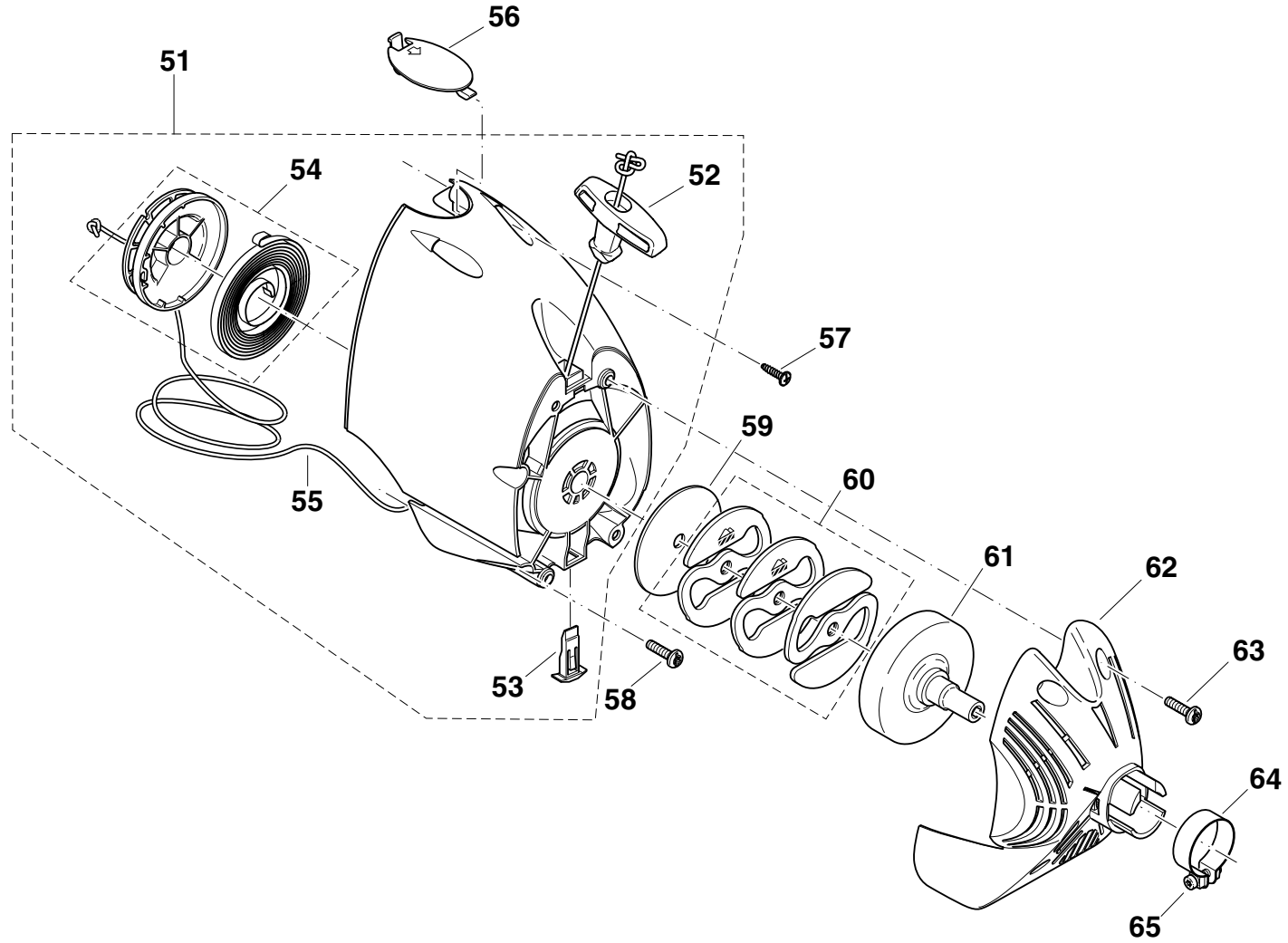

MS-30, MS-31, LT-30



Seite / Page	Pos.	MS-30 U	MS-31 U	MS-30 C	MS-31 C	LT-30	Teil-Nr. Part No. No. de pièce No. de pieza	Hinweise Notes Renseign. Nota	Bezeichnung	Spezifikation Specification	Description	Désignation	Denominación
3	51	1	1	1	1	1	369 160 108	SI 2002/13	Starter kpl.		Starter cpl.	Dispos. de démarrage cpl.	Dispos. de arranque cpl.
3	52	1	1	1	1	1	170 164 020	SI 2002/13	Anwerfgriff		Starter grip	Poignée de lancement	Tirador de arranque
3	53	1	1	1	1	1	369 162 063	SI 2002/13	Halter für Seiltrommel		Holder for cable drum	Cliquet pour tambour de câble	Fijador por tambor para cordón
3	54	1	1	1	1	1	369 162 201	SI 2002/13	Seiltrommel mit Rückholfeder kpl.		Rewind spring and cable drum cpl.	Ressort de rappel et tambour de câble cpl.	Resorte retención y tambor para cordón cpl.
3	55	1	1	1	1	1	985 000 150		Anwerfseil (960mm)	ø3x100m	Starter rope	Câble démarrage	Cordón de arranque
3	56	1	1	1	1	1	369 118 072		Kerzenabdeckung		Cover for spark plug	Couvercle p. bougie	Tapa p. bujía
3	57	2	2	2	2	2	913 540 185		Kreuzschlitz-Schraube	4x18	Screw	Vis	Tornillo
3	58	4	4	4	4	4	913 205 255		Innenstern-Schlitz-Schraube	5x25	Screw	Vis	Tornillo
3	59	1	1	1	1	1	369 188 011		Anlaufscheibe		Stop disc	Disque portante	Disco de tope
3	60	1	1	1	1	1	369 181 110		Kupplungslamellen (Satz)		Clutch (set)	Embrayage (jeu)	Embrague (juego)
3	61	1	1	1	1	1	369 223 101		Kupplungstrommel kpl.		Clutch drum cpl.	Tambour cpl.	Tambor cpl.
3	62	1	1	1	1	1	369 217 013		Kupplungsgehäuse		Clutch case	Carter d'embrayage	Carter de embrague
3	63	4	4	4	4	4	913 660 254		Innenstern-Schlitz-Schraube	6x25	Screw	Vis	Tornillo
3	64	1	1	1	1	1	965 903 080		Spannschelle		Clamping ring	Bride de serrage	Abrazadera
3	65	1	1	1	1	1	908 006 255		Innenstern-Schraube	M6x25	Screw	Vis	Tornillo

MS-30
MS-31
LT-30

4

Vergaser
Carburetor
Carburateur
Carburador

DOLMAR
▨▨▨▨▨▨▨▨▨▨

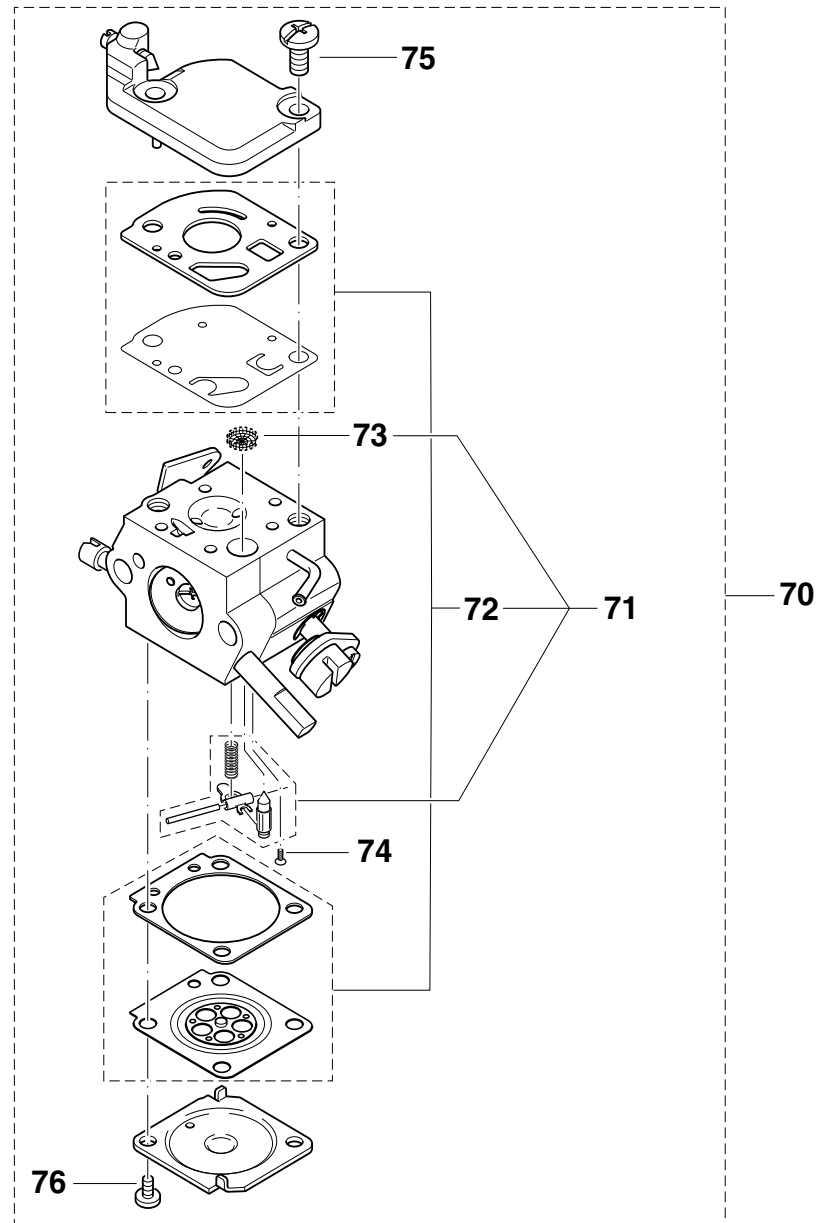

MS-30, MS-31, LT-30

Seite / Page	Pos.	MS-30 U	MS-31 U	MS-30 C	MS-31 C	LT-30	Teil-Nr. Part No. No. de pièce No. de pieza	Hinweise Notes Renseign. Nota	Bezeichnung	Spezifikation Specification	Description	Désignation	Denominación
4	70	1	1	1	1	1	369 153 004		Vergaser kpl.		Carburetor cpl.	Carbureteur cpl.	Carburador cpl.
4	71	1	1	1	1	1	010 153 100		Reparatursatz		Repair kit	Jeu de réparation	Juego de reparar
4	72	1	1	1	1	1	010 153 010		Dichtung & Membran Satz		Gasket & diaphragm kit	Jeu de joint & membrane	Juega junta & membrana
4	73	1	1	1	1	1	001 153 180		Sieb		Screen	Tamis	Tamiz
4	74	1	1	1	1	1	001 153 010		Schraube		Screw	Vis	Tornillo
4	75	2	2	2	2	2	001 153 190		Schraube		Screw	Vis	Tornillo
4	76	2	2	2	2	2	001 153 020		Schraube		Screw	Vis	Tornillo

MS-30
MS-31
LT-30

5

Gasgriff, Handgriff
Operating lever, handle
Levier de réglage, poignée
Botón de mando, mango

DOLMAR
■■■■■■■■■■

MS-30 U
MS-31 U

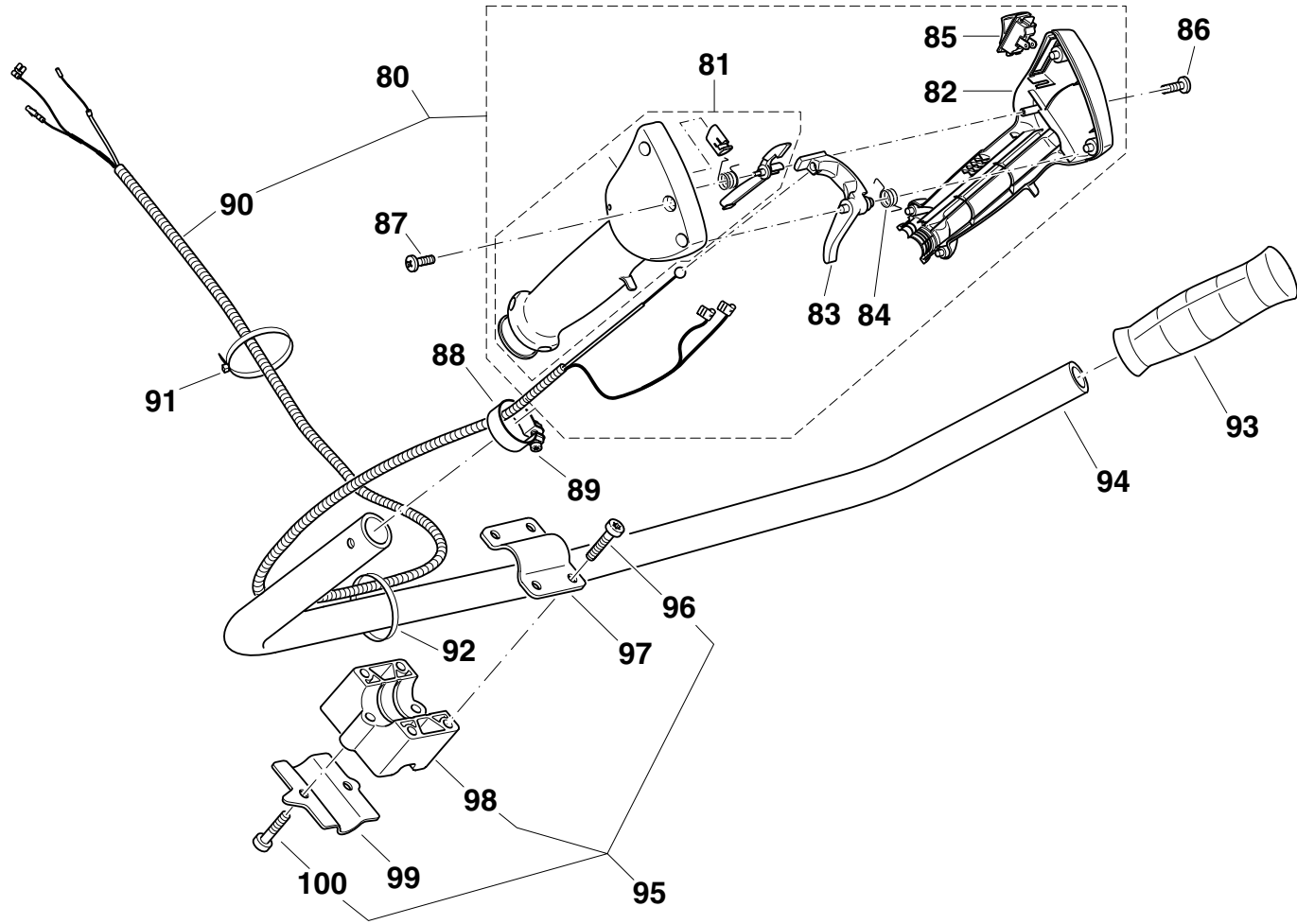

MS-30, MS-31, LT-30



Seite / Page	Pos.	MS-30 U	MS-31 U	MS-30 C	MS-31 C	LT-30	Teil-Nr. Part No. No. de pièce No. de pieza	Hinweise Notes Renseign. Nota	Bezeichnung	Spezifikation Specification	Description	Désignation	Denominación
5	80	1	1				369 313 105		Gasgriff kpl.	ø 22	Operating lever assy.	Levier de réglage, cpl.	Botón de mando, cpl.
5	81	1	1				369 313 291		Griffhälfte rechts kpl.	ø 22	Handle half, right, cpl.	Demi-poignée, droite, cpl.	Semi-mango, derecha, cpl.
5	82	1	1				369 313 011		Griffhälfte links	ø 22	Handle half, left	Demi-poignée, gauche	Semi-mango, izquierda
5	83	1	1				369 311 042		Gashebel		Throttle lever	Levier d'accélération	Acelerador
5	84	1	1				369 311 071		Schenkelfeder für Gashebel		Spring	Ressort	Muelle
5	85	1	1				975 001 210		Kurzschlußschalter		Short-circuit switch	Interrupteur court-circuit	Interruptor corto-circuite
5	86	1	1				915 735 100		Schraube	3,5x9,5	Screw	Vis	Tornillo
5	87	1	1				915 735 100		Schraube	3,5x9,5	Screw	Vis	Tornillo
5	88	1	1				965 903 080		Spannschelle		Clamping ring	Bride de serrage	Abrazadera
5	89	1	1				908 006 255		Innenstern-Schraube	M6x25	Screw	Vis	Tornillo
5	90	1	1				369 726 011		Gaszug kpl.		Bowden cable cpl.	Dispositif de tirage, cpl.	Tracción Bowden, cpl.
5	91	1	1				980 600 100		Flachbinder		Cable strap	Attache câble	Fijador de cable
5	92	1	1				980 600 100		Flachbinder		Cable strap	Attache câble	Fijador de cable
5	93	1	1				387 311 100		Handgriff, links		Handle, left	Poignée, gauche	Mango, izqu.
5	94	1	1				369 310 051		Griffrohr		Handle	Poignée	Mango
5	95	1	1				010 310 030		Klemmblock kpl. inkl. Schrauben		Clamping piece cpl.	Pièce intercalaire cpl.	Reten cpl.
5	96	4	4				908 005 255		Innenstern-Schlitz-Schraube	5x25	Screw	Vis	Tornillo
5	97	1	1				387 310 030		Rohrschelle		Clamping holder	Dispositif de serrage	Soporte presor
5	98	1	1				369 310 030		Klemmblock (Aluminium)		Clamping piece (alumin.)	Pièce intercalaire (aluminium)	Reten (aluminio)
5	99	1	1				369 310 020		Klemmschelle		Clamping holder	Dispositif de serrage	Soporte presor
5	100	2	2				908 005 255		Innenstern-Schlitz-Schraube	5x25	Screw	Vis	Tornillo

MS-30
MS-31
LT-30

6

Gasgriff, Handgriff
Operating lever, handle
Levier de réglage, poignée
Botón de mando, mango

DOLMAR
■■■■■■■■■■

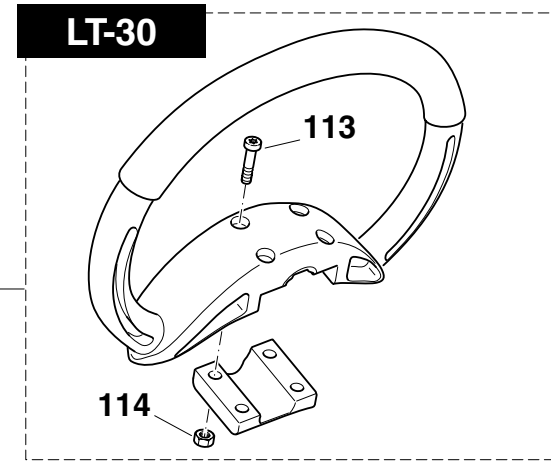
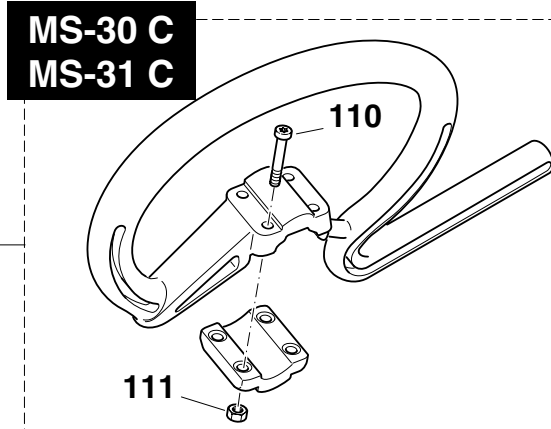
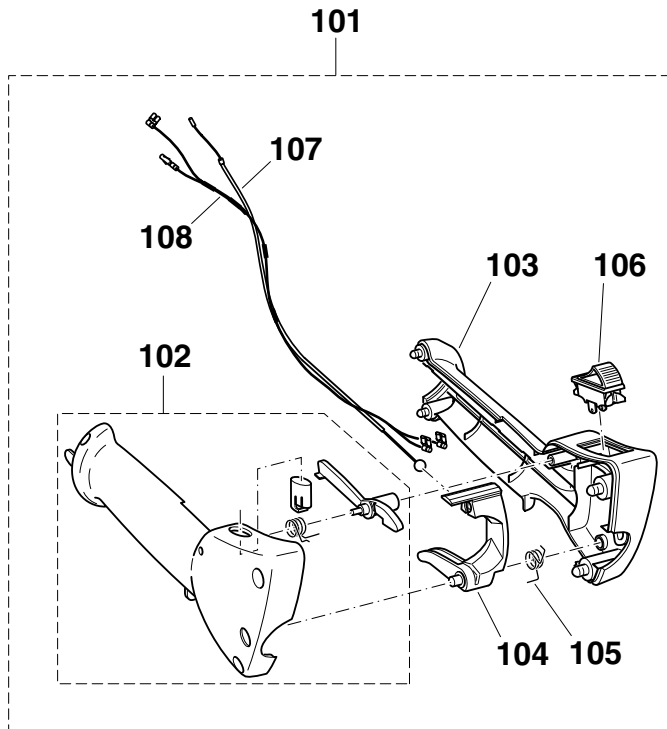

MS-30, MS-31, LT-30

DOLMAR

Seite / Page	Pos.	MS-30 U	MS-31 U	MS-30 C	MS-31 C	LT-30	Teil-Nr. Part No. No. de pièce No. de pieza	Hinweise Notes Renseign. Nota	Bezeichnung	Spezifikation Specification	Description	Désignation	Denominación
6	101			1	1	1	369 311 105		Gasgriff kpl.	ø 25	Operating lever assy.	Levier de réglage, cpl.	Botón de mando, cpl.
6	102			1	1	1	369 311 291		Griffhälfte rechts kpl.	ø 25	Handle half, right, cpl.	Demi-poignée, droite, cpl.	Semi-mango, derecha
6	103			1	1	1	369 311 011		Griffhälfte links	ø 25	Handle half, left	Demi-poignée, gauche	Semi-mango, izquierda, cpl.
6	104			1	1	1	369 311 042		Gashebel		Throttle lever	Levier d' accélération	Acelerador
6	105			1	1	1	369 311 071		Schenkelfeder für Gashebel		Spring	Ressort	Muelle
6	106			1	1	1	975 001 210		Kurzschlußschalter		Short-circuit switch	Interrupteur court-circuit	Interruptor corto-circuite
6	107			1	1	1	965 725 072		Bowdenzug, kurz		Bowden cable	Câble de commande	Tranmis. flexible Bowden
6	108			1	1	1	970 311 510		Kurzschlußkabel, kurz		Short-circuit cable	Câble courte-circuit	Cable corto-circuito
6	109			1	1		957 310 040		Handgriff mit Barriere kpl.		Handle cpl.	Poignée cpl.	Mango cpl.
6	110			4	4		908 005 305		Innenstern-Schraube	M5x30	Screw	Vis	Tornillo
6	111			4	4		920 205 000		6kt-Mutter	M5	Hexagonal nut	Ecrou hexagonal	Tuerca hexagonal
6	112					1	957 310 030		Handgriff kpl.		Handle cpl.	Poignée cpl.	Mango cpl.
6	113					4	908 005 205		Innenstern-Schraube	M5x20	Screw	Vis	Tornillo
6	114					4	920 205 000		6kt-Mutter	M5	Hexagonal nut	Ecrou hexagonal	Tuerca hexagonal

MS-30
MS-31
LT-30

7

Schaftrohr, Getriebe, Schutzhaube
Main pipe, gear, protection hood
Tube principal, engrenage, capot de protection
Tubo principal, engranaje, cubierta protectora

DOLMAR



**MS-30 U
MS-31 U
MS-30 C
MS-31 C**

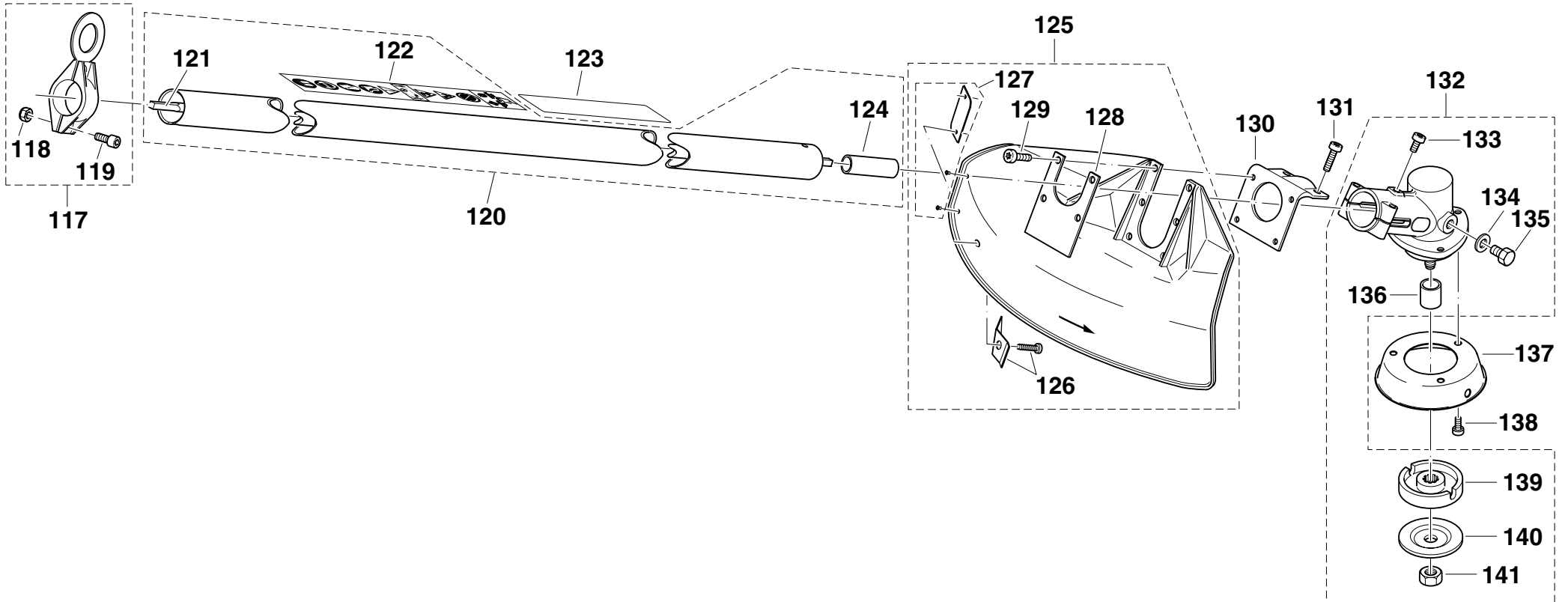
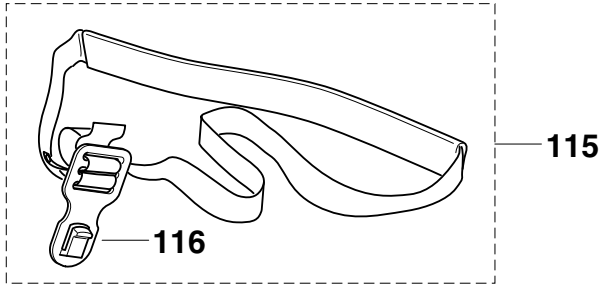

MS-30, MS-31, LT-30



Seite / Page	Pos.	MS-30 U	MS-31 U	MS-30 C	MS-31 C	LT-30	Teil-Nr. Part No. No. de pièce No. de pieza	Hinweise Notes Renseign. Nota	Bezeichnung	Spezifikation Specification	Description	Désignation	Denominación
7	115	1	1	1	1		369 260 300		Schultergurt		Shoulder harness	Bretelle	Harness
7	116	1	1	1	1		369 260 310		Haken für Schultergurt		Hook for shoulder harness	Crochet pour bretelle	Corchete p. harness
7	117	1	1	1	1		957 260 010		Gurtaufnahme kpl.		Harness attachment cpl.	Attache de bretelle cpl.	Sujeción cpl.
7	118	2	2	2	2		920 205 000		6kt-Mutter	M5	Hexagonal nut	Ecrou hexagonal	Tuerca hexagonal
7	119	2	2	2	2		908 005 125		Innenstern-Schraube	M5x12	Screw	Vis	Tornillo
7	120	1		1			010 261 040		Schaftrohr kpl.		Main pipe assy.	Tube principal cpl.	Tubo principal cpl.
7	120	1	1		1		010 261 060	AUS, YV	Schaftrohr kpl.		Main pipe assy.	Tube principal cpl.	Tubo principal cpl.
7	121	1		1			369 228 141		Flexwelle		Transmission shaft	Arbre de transmission	Arbol de transmisión
7	121	1	1		1		369 228 150	AUS, YV	Hauptwelle		Transmission shaft	Arbre de transmission	Arbol de transmisión
7	122	1	1	1	1		980 114 484		Schild		Label	Plaque	Calcomania
7	123	1	1	1	1		980 114 073		Schild		Label	Plaque	Calcomania
7	124	1	1	1	1		369 261 150		Distanzbuchse		Spacer	Douille de distance	Casquillo separador
7	125	1	1	1	1		010 341 202		Schutzhaube kpl.		Protection hood assy.	Capot de protection cpl.	Cubierta protectora cpl.
7	126	1	1	1	1		957 341 010		Fadenmesser kpl.		Line cutter cpl.	Couteau de fil cpl.	Cuchilla de hilos cpl.
7	127	=	=	=	=		957 341 020		Schutzhaubenverstärkung kpl.		Prot. cov. reinforcem. cpl.	Renfort de capot de prot. cpl.	Refuerzo cubierta cpl.
7	128	1	1	1	1		385 341 021		Unterlegplatte		Plate	Plaque	Plancha
7	129	4	4	4	4		908 005 095		Innenstern-Schraube	M5x9	Screw	Vis	Tornillo
7	130	1	1	1	1		387 341 031		Flanschblech		Flange plate	Équerre de fixation	Chapa de brida
7	131	2	2	2	2		908 005 255		Innenstern-Schraube	M5x25	Screw	Vis	Tornillo
7	132	1	1	1	1		369 200 201		Getriebe kpl.	ø 20 mm	Gear cpl.	Engrenage cpl.	Engranaje cpl.
7	132			1			369 200 300	only for Italy	Getriebe kpl.	ø 25,4 mm	Gear cpl.	Engrenage cpl.	Engranaje cpl.
7	133	1	1	1	1		908 005 095		Innenstern-Schraube	M5x9	Screw	Vis	Tornillo
7	134	1	1	1	1		963 604 306		Dichtung		Gasket	Joint	Junta
7	135	1	1	1	1		900 208 104		6kt-Schraube	M8x1,25x10	Screw	Vis	Tornillo
7	136	1	1	1	1		387 228 020		Distanzring		Distance ring	Bague de distance	Anillo separador
7	137	1	1	1	1		387 224 050		Wickelschutz		Winding preventer	Capot de protection	Tapa protectora
7	138	3	3	3	3		908 005 095		Innenstern-Schraube	M5x9	Screw	Vis	Tornillo
7	139	1	1	1	1		387 224 011		Aufnahmescheibe	ø 20 mm	Mounting disc	Disque de support	Disco de sujeción
7	139			1			369 224 030	only for Italy	Aufnahmescheibe	ø 25,4 mm	Mounting disc	Disque de support	Disco de sujeción
7	140	1	1	1	1		387 224 021		Druckscheibe		Pressure disc	Disque de pression	Disco de presión
7	141	1	1	1	1		387 228 040		Sicherungsmutter	M10x1,25L	Safety nut	Ecrou de sécurité	Tuerca seguridad

MS-30
MS-31
LT-30

8

Schaftrohr, Schutzhaube
Main pipe, protection hood
Tube principal, capot de protection
Tubo principal, cubierta protectora

DOLMAR
■■■■■■■■■■

LT-30

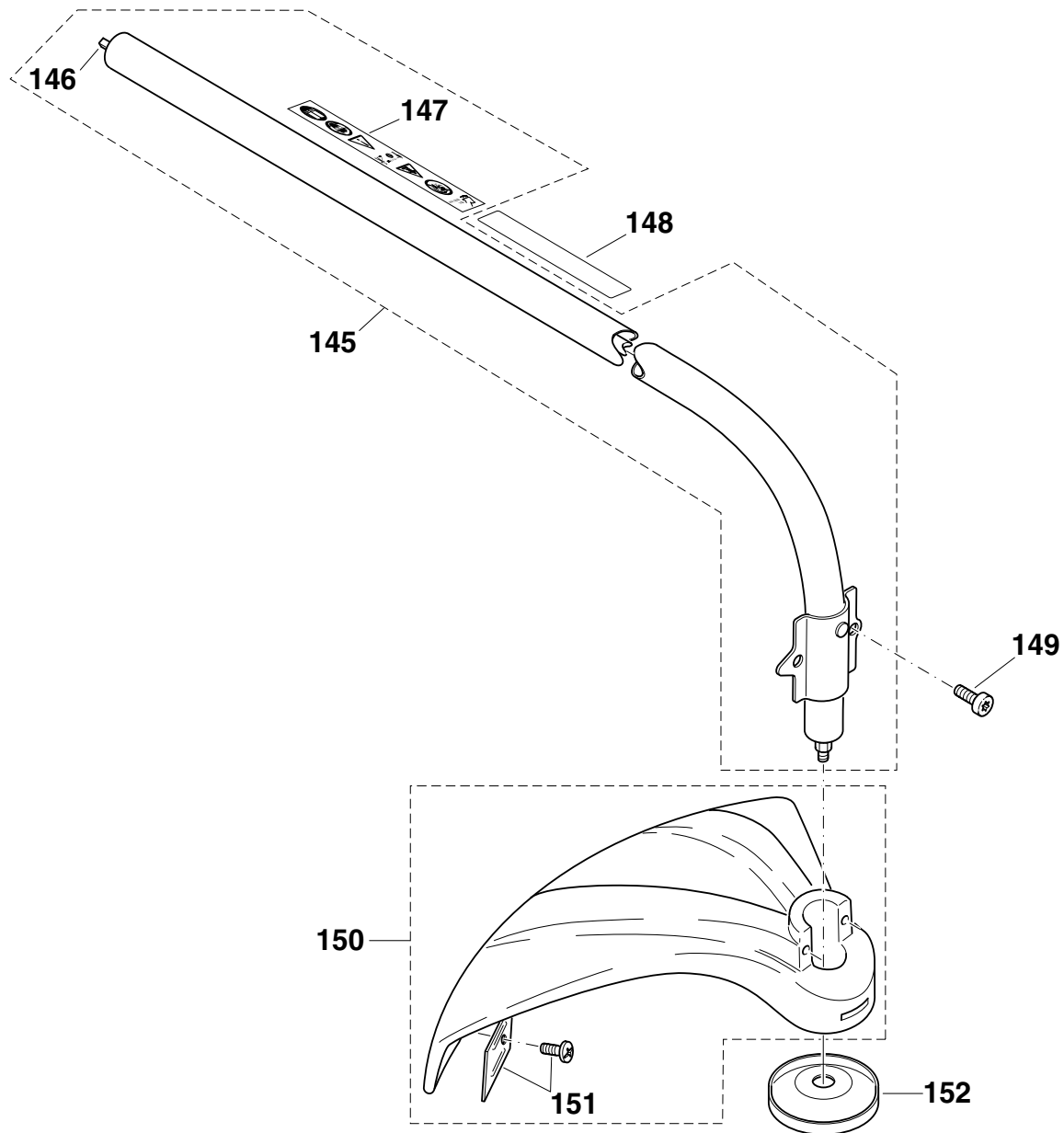

MS-30, MS-31, LT-30
DOLMAR

Seite / Page	Pos.	MS-30 U	MS-31 U	MS-30 C	MS-31 C	LT-30	Teil-Nr. Part No. No. de pièce No. de pieza	Hinweise Notes Renseign. Nota	Bezeichnung	Spezifikation Specification	Description	Désignation	Denominación
8	145					1	010 261 050		Schaftrohr gebogen kpl.		Main pipe assy.	Tube principal cpl.	Tubo principal cpl.
8	146					1	369 228 121		Flexwelle		Transmission shaft	Arbre de transmission	Arbol de transmisión
8	147					1	980 114 485		Schild		Label	Plaque	Calcomania
8	148					1	980 114 073		Schild		Label	Plaque	Calcomania
8	149					2	913 660 254		Innenstern-Schlitz-Schraube	6x25	Screw	Vis	Tornillo
8	150					1	369 341 100		Schutzhaube kpl.		Protection hood assy.	Capot de protection cpl.	Cubierta protectora cpl.
8	151					1	957 341 030		Fadenmesser kpl.		Line cutter cpl.	Couteau de fil cpl.	Cuchilla de hilos cpl.
8	152					1	369 224 410		Wickelschutz		Winding preventer	Capot de protection	Tapa protectora

MS-30
MS-31
LT-30

9

Schneidwerkzeuge, Werkzeug
Cutting tools, tools
Outils tranchants, outils
Herramientas de corte, herramientas

DOLMAR
■■■■■■■■■■

LT-30

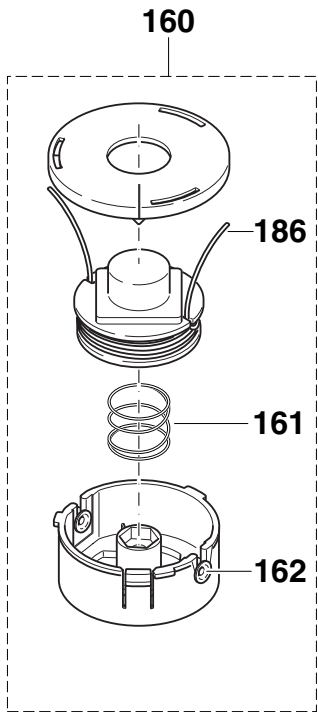

**MS-30 U, MS-31 U
MS-30 C, MS-31 C**

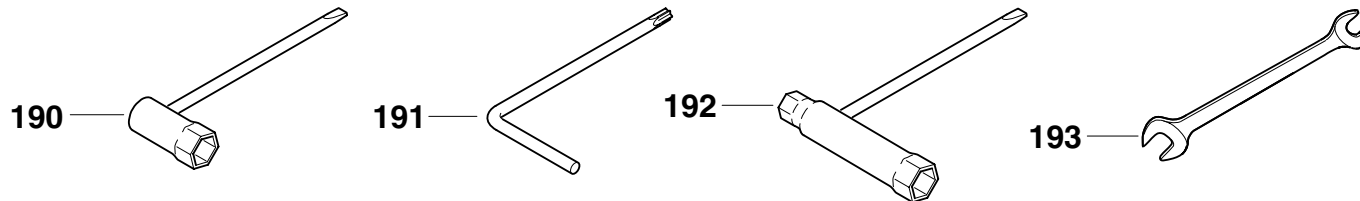
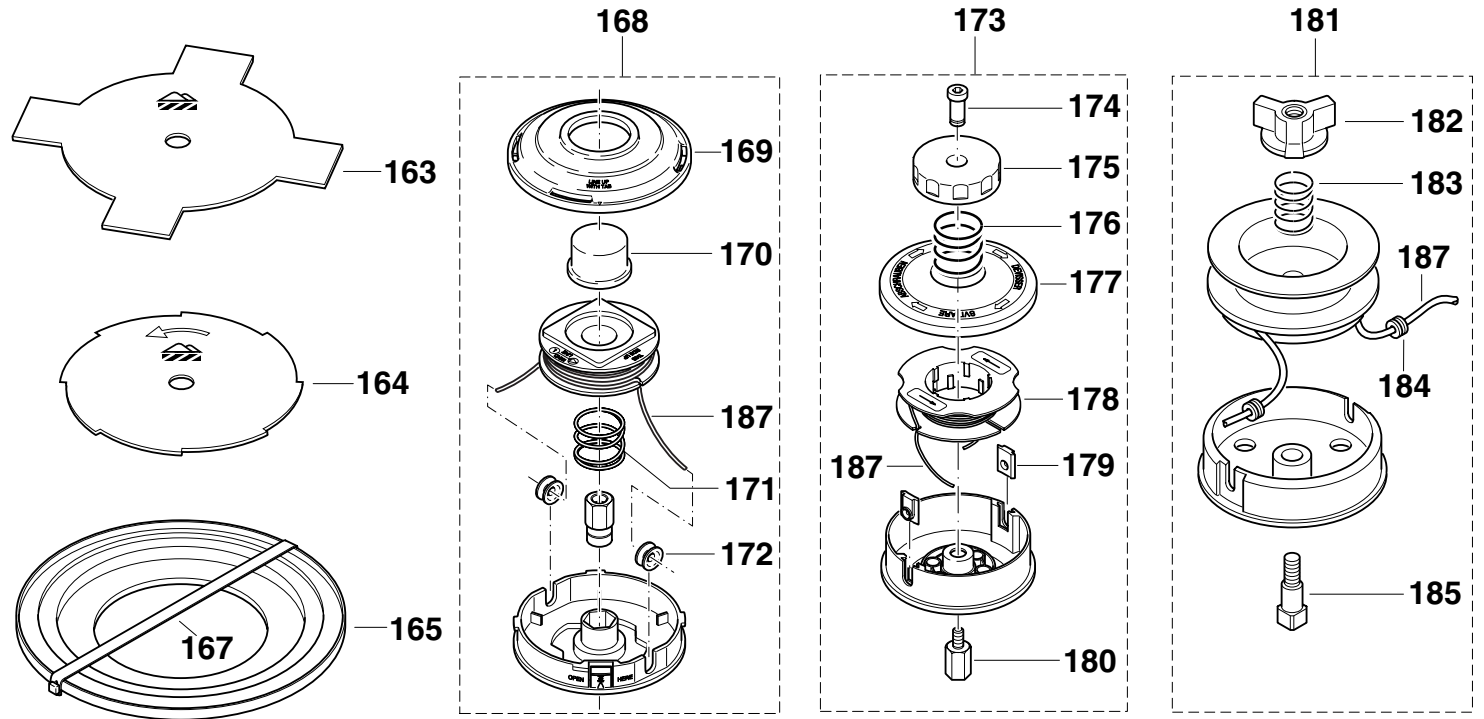

MS-30, MS-31, LT-30



Seite / Page	Pos.	MS-30 U	MS-31 U	MS-30 C	MS-31 C	LT-30	Teil-Nr. Part No. No. de pièce No. de pieza	Hinweise Notes Renseign. Nota	Bezeichnung	Spezifikation Specification	Description	Désignation	Denominación
9	160					1	369 224 101		2-Fadenkopf	tap&go (ø2,0mm)	Dual line trimming head	Tête à 2 fils de nylon	Cabezal de 2 hilos de nilón
9	161					1	378 224 030		Feder		Spring	Ressort	Muelle
9	162					2	369 224 010		Fadenbuchse		Thread bush	Douille de fil	Buje de hilo
9	163	1	1	1	1		372 224 140		4-Zahn-Schlagmesser	ø 200	Star blade	Couteau à 4 dents	Cuchilla de acero de 4 die.
9	164	1	1	1	1		380 224 180	Acc.	8-Zahn-Wirbelblatt	ø 200	8-tooth eddy blade	Disque à 8 dents	Disco de corte de 8 dient.
9	165	1	1	1	1		370 341 450		Transportschutz		Protection case	Enveloppe	Envoltura protectora
9	167	1	1	1	1		370 341 410		Befestigung		Clamping rubber	Fixation	Fijación
9	168	1	1	1	1		369 224 201		2-Fadenkopf	tap&go (ø2,0mm)	Dual line trimming head	Tête à 2 fils de nylon	Cabezal de 2 hilos de nilón
9	169	1	1	1	1		369 224 020		Deckel		Cover	Couvercle	Tapa
9	170	1	1	1	1		369 224 040		Druckknopf		Button	Bouton	Botón
9	171	1	1	1	1		378 224 030		Feder		Spring	Ressort	Muelle
9	172	2	2	2	2		378 224 020		Fadenbuchse		Thread bush	Douille de fil	Buje de hilo
9	173	1	1	1	1		384 224 502	Acc.	2-Fadenkopf	automatik (ø2,4mm)	Dual line trimming head	Tête à 2 fils de nylon	Cabezal de 2 hilos de nilón
9	174	1	1	1	1		384 224 540	Acc.	Druckknopf		Screw plug	Embout de vissage	Alojamiento de tornillos
9	175	1	1	1	1		384 224 530	Acc.	Druckknopf		Button	Bouton	Botón
9	176	1	1	1	1		384 224 510	Acc.	Feder		Spring	Ressort	Muelle
9	177	1	1	1	1		384 224 520	Acc.	Deckel		Cover	Couvercle	Tapa
9	178	1	1	1	1		385 224 570	Acc.	Spule mit Faden	ø2,4x6m	Spool with line	Bobine avec fil	Bobina con hilo
9	179	2	2	2	2		385 224 560	Acc.	Fadenbuchse		Thread bush	Douille de fil	Buje de hilo
9	180	1	1	1	1		387 224 590	Acc.	Adapter	M10 x 1,25 L	Adaptor	Adaptateur	Adaptador
9	181	1	1	1	1		387 224 500	Acc.	2-Fadenkopf	manuell (ø2,4mm)	Dual line trimming head	Tête à 2 fils de nylon	Cabezal de 2 hilos de nilón
9	182	1	1	1	1		370 224 630	Acc.	Mutter		Nut	Ecrou	Tuerca
9	183	1	1	1	1		370 224 620	Acc.	Feder		Spring	Ressort	Muelle
9	184	2	2	2	2		378 224 020	Acc.	Fadenbuchse		Thread bush	Douille de fil	Buje de hilo
9	185	1	1	1	1		380 224 170	Acc.	Adapter	M10 x 1,25 L	Adaptor	Adaptateur	Adaptador
9	186	1	1	1	1	1	378 224 060	Acc.	Faden	ø 2,0 x 15 m	Nylon line	Fil de nylon	Hilo de nilón
9	186	1	1	1	1	1	369 224 060	Acc.	Leiser Faden	ø 2,0 x 15 m	Silent nylon line	Fil de coupe silencieux	Hilo cortante silencioso
9	187	1	1	1	1		362 224 160	Acc.	Faden	ø 2,4 x 15 m	Nylon line	Fil de nylon	Hilo de nilón
9	187	1	1	1	1		369 224 070	Acc.	Leiser Faden	ø 2,4 x 15 m	Silent nylon line	Fil de coupe silencieux	Hilo cortante silencioso
9	190	1	1	1	1		941 717 001		Kombischlüssel	SW 17	Universal wrench	Clé combinée	Llave
9	191	1	1	1	1	1	940 827 000		Winkelschraubendreher	T27	Angled screw driver	Clé angle	Llave angular
9	192	1	1	1	1	1	941 713 191	Acc.	Kombischlüssel	SW 13/19	Universal wrench	Clé combinée	Llave de bujía
9	193					1	944 500 800	Acc.	Maulschlüssel	SW 10/13	Spanner	Clé plate	Llave de boca

MS-30
MS-31
LT-30

Inhaltsverzeichnis
Index
Table des matières
Indice

DOLMAR



1	Luftfilter, Tank, Motorhaube	Air filter, tank, motor hood	Filtre à air, réservoir, capot du moteur	Filtro de aire, depósito, carter de motor
2	Zylinder, Kurbelgehäuse	Cylinder, crankcase	Cylindre, carter-vilebrequin	Cilíndro, carter cigüeñal
3	Starter, Kupplung	Starter, clutch	Dispositif de démarrage, embrayage	Dispositivo de arranque, embrague
4	Vergaser	Carburetor	Carbureteur	Carburador
5 - 6	Gasgriff, Handgriff	Operating lever, handle	Levier de réglage, poignée	Botón de mando, mango
7 - 8	Schaftrohr, Getriebe, Schutzhaube	Main pipe, gear, protection hood	Tube principal, engrenage, capot de protection	Tubo principal, engranaje, cubierta protectora
9	Schneidwerkzeuge, Werkzeug	Cutting tools, tools	Outils tranchants, outils	Herramientas de corte, herramientas

	Zeichenerklärung (D)	Key to symbols (GB)	Légende (F)	Explicación de símbolos (E)
<p>⇒ 1999999 2000000 ⇒ 4/95 ⇒ SI 5/95 Acc. = { m Corr.</p>	<p>Produktion bis Serien-Nr. Neues Teil ab Serien-Nr. Neues Teil ab Monat / Jahr Siehe Technische Information Jahr / Nr. Zubehör (nicht im Lieferumfang) Keine Serienausführung, jedoch verwendbar Beinhaltet Positions-Nr. Meterware Druckfehlerberichtigung</p>	<p>Production to serial number New part from serial number New part from Month / Year See Technical Information Year / No. Accessories (not included in the delivery inventory) No standard execution, may be used Contains item number Sold by the meter Error correction</p>	<p>Production jusqu'à n° de série Nouvelle pièce à partir du n° de série Nouvelle pièce à partir de mois / année Voir information technique année / n° Accessoires (non compris dans la livraison) Aucune exécut. en série, cependant utilisable contient n° de numéro Au mètre Rectification d'erreurs</p>	<p>Producción hasta N° de serie Pieza nueva a partir de N° de serie Pieza nueva a partir de mes / año Véase inform. técnico año / N° Accesorios (no incluido en la extensión del suministro) No es de serie, pero sirve Contiene pos N° Por metro Fe de erratas</p>
	Verklaring der tekens (NL)	Chiarificazione dei simboli (I)	Objasnitev znakov (SLO)	Επεξήγηση συμβόλων (GR)
<p>⇒ 1999999 2000000 ⇒ 4/95 ⇒ SI 5/95 Acc. = { m Corr.</p>	<p>In productie tot serie-Nr. Nieuw onderdeel vanaf serie-Nr. Nieuw onderdeel vanaf maand / jaar Zie technische informatie jaar / Nr. Accessoires (niet meegeleverd) Geen serieuitvoering, maar wel bruikbaar Omvat Positie-Nr. Metergoed Drukfoutcorrectie</p>	<p>Produzione fino al n. di serie Nuovo pezzo a partire dal n. di serie Nuovo pezzo a partire dal mese / anno Vedere il inform. tecnici del anno / n. Accessori (non compresi nell'insieme di fornitura) Non è un modello di serie, ma ugualm. utilizza. Comprende la posizione n. Articoli a metraggio Rettifica di errori di stampa</p>	<p>Produkcija do serijske številke Novi del od serijske številke Novi del od meseca / leta dalje Glej tehnične informacije od leta / številke. Pritikline (niso v obsegu dostave) Ni serijska izvedba, a uporabno Vsebuje pozicijsko število. Metrsko blago Popravek tiskovnih napak</p>	<p>Παραγωγή μέχρι τον αριθμό σειράς Νέο εξάρτημα από τον αριθμό σειράς Νέο εξάρτημα από το μήνα / έτος Βλέπε πληροφορίες του τεχνικά το έτος / αριθμό Πρόσθετα εξαρτήματα (δεν ανήκουν στη συσκευασία παράδοσης) Δεν έχει εκδοθεί σε σειρά, αλλά χρησιμοποιείται Περιλαμβάνει τον αριθμό θέσης Εμπόρευμα με το μέτρο Διόρθωση λάθους πίεσης</p>