

Ersatzteilliste
Spare Parts List
Liste de pièces détachées
Lista de piezas de repuesto

2006-09

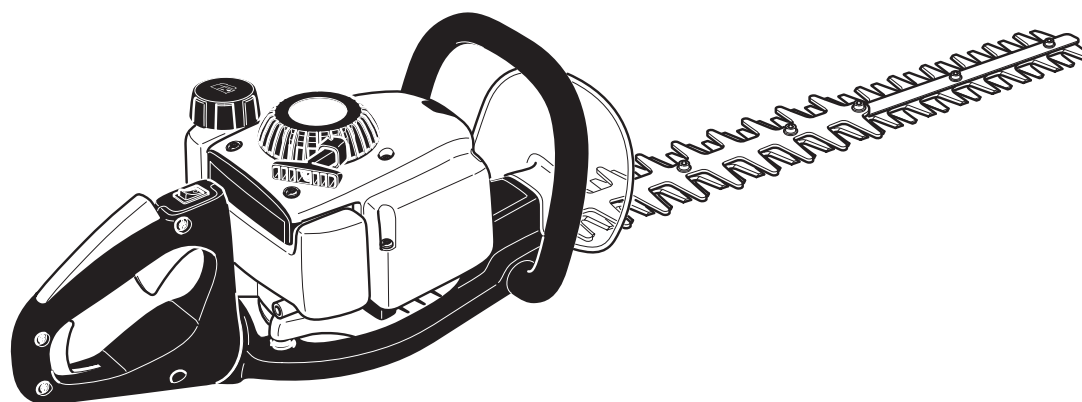

HT-245

HT-255

HT-2950

HT-2960

HT-2975

DOLMAR



A member of the *Makita* Group

995 700 222 (DE, GB, FR, ES)

HT-245
HT-255
HT-2950
HT-2960
HT-2975

1

Motor, Kurbelwelle
Motor, ckrankshaft
Moteur, vilebrequin
Motor, cigüeñal

DOLMAR
//

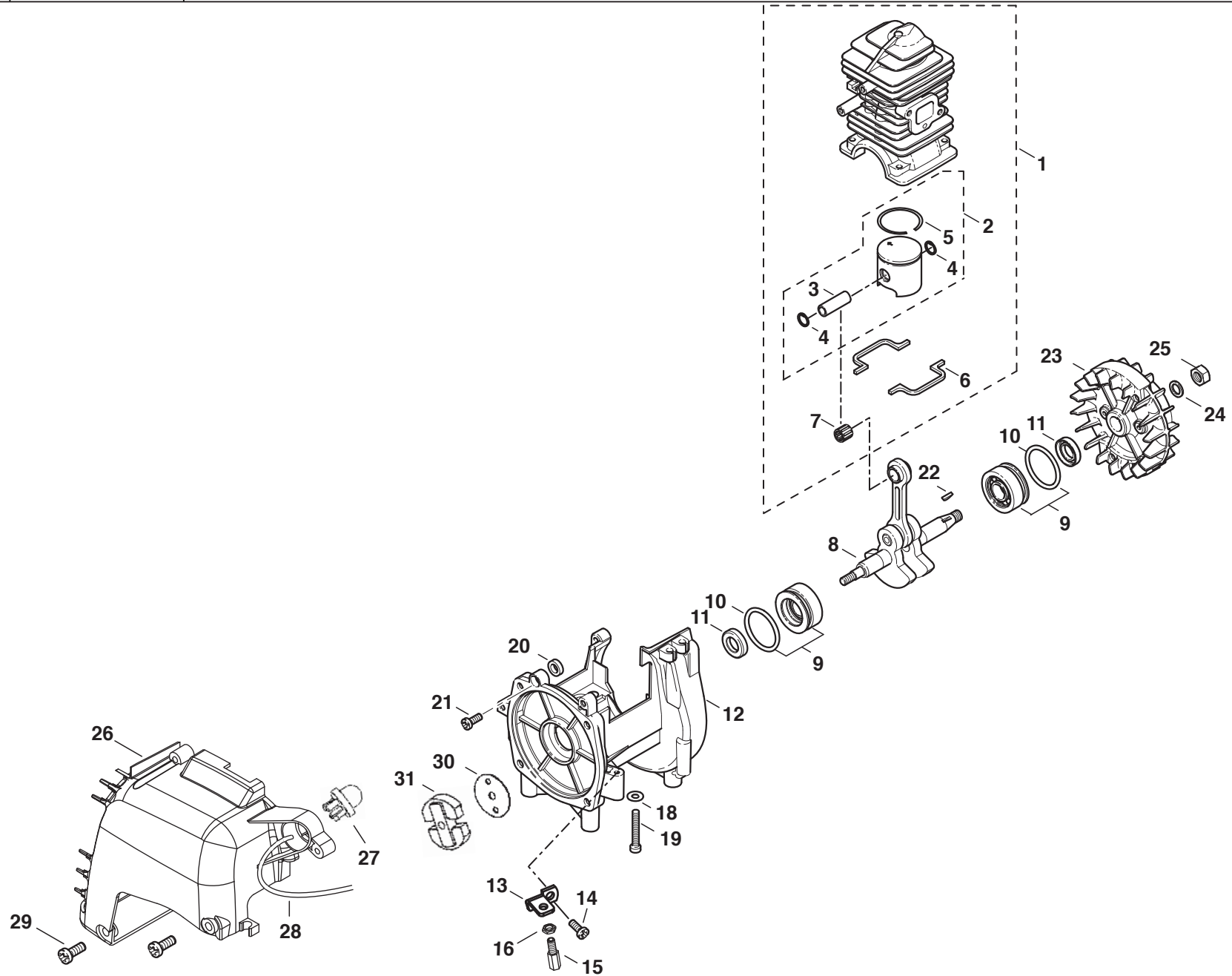

**HT-245, 255
HT-2950, 2960, 2975**



Seite / Page	Pos.	HT-245	HT-255	HT-2950	HT-2960	HT-2975	Teil-Nr. Part No. No. de pièce No. de pieza	Hinweise Notes Renseign. Nota	Bezeichnung	Spezifikation Specification	Description	Désignation	Denominación
1	1	1	1				302 200 160		Zylinder + Kolben kpl.	Ø 33	Cylinder + piston cpl.	Cylindre + piston cpl.	Cilindro + piston cpl.
1	1			1	1	1	302 200 161		Zylinder + Kolben kpl.	Ø 35	Cylinder + piston cpl.	Cylindre + piston cpl.	Cilindro + piston cpl.
1	2	1	1				302 200 162		Kolben kpl.	Ø 33	Piston cpl.	Piston cpl.	Piston cpl.
1	2			1	1	1	302 200 163		Kolben kpl.	Ø 35	Piston cpl.	Piston cpl.	Piston cpl.
1	3	1	1	1	1	1	302 031 902		Kolbenbolzen	9/6x26	Piston pin	Axe de piston	Perno de embolo
1	4	2	2	2	2	2	300 055 278		Sicherungsring	9x0,8	Circlip	Arrêt axe de piston	Anillo de seguridad
1	5	1	1				302 048 377		Kolbenring	33x1,5	Piston ring	Segment de piston	Anillo de piston
1	5			1	1	1	302 048 346		Kolbenring	35x1,5	Piston ring	Segment de piston	Anillo de piston
1	6	2	2	2	2	2	302 063 372		Dichtungsteil		Sealing	Joint carter moteur	Junta
1	7	1	1	1	1	1	300 052 226		Nadelhülse	9x13x12,5	Needle sleeve	Douille	Casquillo
1	8	1	1	1	1	1	302 200 304		Kurbelwelle		Crankshaft	Vilebrequin	Cigüenal
1	9	2	2	2	2	2	302 100 121		Lagerhülse	12x34,17x15,5	Sleeve	Douille	Casquillo
1	10	2	2	2	2	2	300 062 335		O-Ring	27x3	O-ring	Joint torique	Anillo de guarnición
1	11	2	2	2	2	2	300 054 258		Wellendichtring	12x22x5	Oil seal	Joint d'arbre	Reten
1	12	1	1	1	1	1	302 100 122		Kurbelgehäuse		Crankcase	Carter moteur	Carter cigüenal
1	13	1	1	1	1	1	302 043 324		Widerlager Gaszug		Support	Butée cable de gaz	Soporte
1	14	1	1	1	1	1	300 018 361		Linsenschraube	5x12	Screw	Vis	Tornillo
1	15	1	1	1	1	1	300 011 105		Verstellschraube	M6x14	Screw	Vis	Tornillo
1	16	1	1	1	1	1	300 020 116		Sechskantmutter	M6	Hex. nut	Ecrou	Tuerca
1	18	4	4	4	4	4	300 072 140		Scheibe	5,2x12x0,5	Washer	Rondelle	Arandela
1	19	4	4	4	4	4	300 018 399		Zylinderschraube	M5x35	Screw	Vis	Tornillo
1	20	1	1	1	1	1	302 074 562		Isolierelement		Insulating element	Élément d'isolation	Elemento aislante
1	21	1	1	1	1	1	300 018 326		Zylinderschraube	M4x16	Screw	Vis	Tornillo
1	22	1	1	1	1	1	300 075 100		Scheibenfeder	2x3,7	Spring	Clavette	Resorte
1	23	1	1	1	1	1	302 400 311		Lüfterrad		Fan wheel	Turbine	Turbina
1	24	1	1	1	1	1	300 072 176		Scheibe	8,2x20x1	Washer	Rondelle	Arandela
1	25	1	1	1	1	1	300 020 206		Sechskantmutter	M8x1	Hex. nut	Ecrou	Tuerca
1	26	1	1	1	1	1	304 073 162		Abdeckhaube		Cover	Capot	Cubierta
1	27	1	1	1	1	1	302 700 322		Primer		Primer	Pompe d'amorcage	Cebador
1	28	m	m	m	m	m	300 064 407		Schlauch	2x1,5 x 80mm	Hose	Tuyau	Tubo
1	29	2	2	2	2	2	300 018 274		Linsenschraube	5x16	Screw	Vis	Tornillo
1	30	1	1	1	1	1	300 031 626		Scheibe	8,1x32x1	Washer	Rondelle	Arandela
1	31	1	1	1	1	1	303 500 465		Kupplung		Clutch	Embrayage	Embrague

HT-245
HT-255
HT-2950
HT-2960
HT-2975

2

Luftfilter, Vergaser, Schalldämpfer
Air filter, carburetor, muffler
Filtre à air, carburateur, pot d' échappement
Filtro de aire, carburador, silencioso

DOLMAR
//

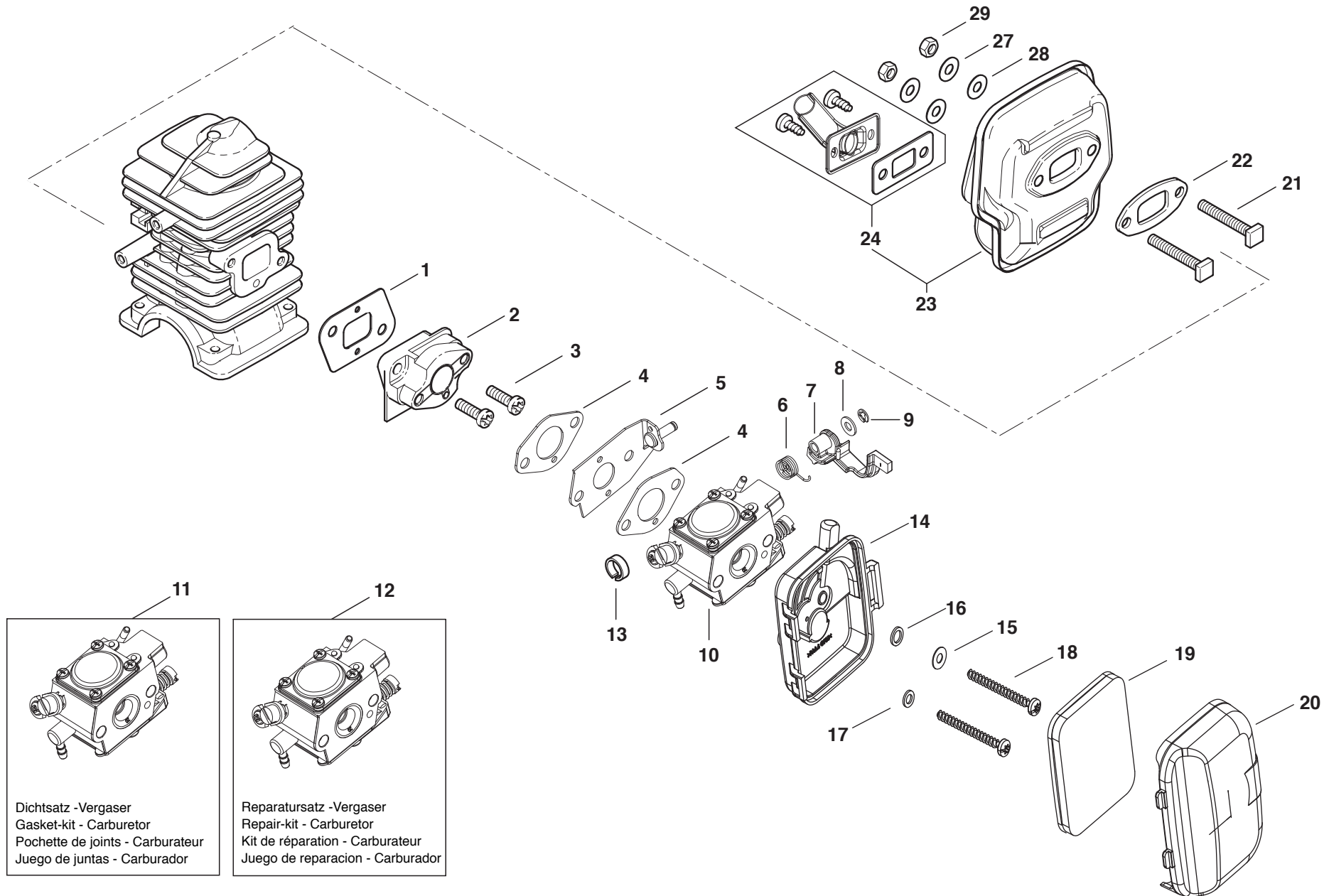

HT-245, 255
HT-2950, 2960, 2975



Seite / Page	Pos.	HT-245	HT-255	HT-2950	HT-2960	HT-2975	Teil-Nr. Part No. No. de pièce No. de pieza	Hinweise Notes Renseign. Nota	Bezeichnung	Spezifikation Specification	Description	Désignation	Denominación
2	1	1	1	1	1	1	302 061 518		Vergaserstutzendichtung		Manifold gasket	Joint de bride	Junta de brida
2	2	1	1	1	1	1	302 074 111		Ansaugstutzen		Socket	Bride d'aspiration	Brida
2	3	2	2	2	2	2	300 018 337		Zylinderschraube	M5x20	Screw	Vis	Tornillo
2	4	2	2	2	2	2	302 061 464		Vergaserdichtung		Carburetor gasket	Joint de carburateur	Junta carburador
2	5	1	1	1	1	1	302 300 110		Lagerblech		Metal Manifold	Bride métallique	Brida de metal
2	6	1	1	1	1	1	300 073 341		Schenkelfeder		Spring	Ressort d'interrupteur	Muelle
2	7	1	1	1	1	1	302 074 801		Schlepphebel		Lever	Levier	Palanca
2	8	1	1	1	1	1	300 030 135		Scheibe	4,3	Washer	Rondelle	Arandela
2	9	1	1	1	1	1	300 055 103		Sicherungsscheibe	3,2	Safety washer	Rondelle de sécurité	Arandela seguridad
2	10	1	1	1	1	1	302 300 836		Vergaser	WT-796A	Carburetor	Carburateur	Carburador
2	11	1	1	1	1	1	300 510 985		Dichtsatz		Gasket kit	Jeu de joints	Juego de juntas
2	12	1	1	1	1	1	300 510 984		Reparatur-/Dichtsatz		Repair kit	Jeu de réparation	Juego rep.
2	13	1	1	1	1	1	302 074 905		Haltering		Retaining ring	Bague de support	Anillo soporte
2	14	1	1	1	1	1	302 500 819		Luftfiltergehäuse Unterteil		Filter housing	Carter filtre	Carter de filtro
2	15	1	1	1	1	1	300 061 360		Scheibe	6,8x10x1,2	Washer	Rondelle	Arandela
2	16	1	1	1	1	1	300 072 140		Scheibe	5,2x12x0,5	Washer	Rondelle	Arandela
2	17	1	1	1	1	1	300 034 100		Sicherungsscheibe		Safety washer	Rondelle de sécurité	Arandela seguridad
2	18	2	2	2	2	2	300 018 429		Linsenschraube	5x50	Screw	Vis	Tornillo
2	19	1	1	1	1	1	302 500 816		Filter		Filter	Filtre	Filtro
2	20	1	1	1	1	1	304 073 430		Luftfiltergehäuse Oberteil		Filter lid	Chapeau filtre	Tapa de filtro
2	21	2	2	2	2	2	300 018 365		Vierkantschraube	M5x40	Square nut	Ecrou	Tuerca
2	22	1	1	1	1	1	302 061 197		Auspuffdichtung		Exhaust gasket	Joint d'échappement	Junta escape
2	23	1	1	1	1	1	302 500 828		Auspuff		Exhaust	Echappement	Escape
2	24	1	1	1	1	1	302 500 829		Funkenschutzsieb kpl.		Spark Arrestor Screen cpl.	Défecteur d' étoucelles cpl.	Deflector contra chispa cpl.
2	27	2	2	2	2	2	300 072 140		Scheibe	5,2x12x0,5	Washer	Rondelle	Arandela
2	28	2	2	2	2	2	300 072 144		Sicherungsscheibe		Safety washer	Rondelle de sécurité	Arandela seguridad
2	29	2	2	2	2	2	300 028 137		Sechskantmutter	M5	Hex. nut	Ecrou	Tuerca

HT-245
HT-255
HT-2950
HT-2960
HT-2975

3

Zündung
Ignition
Allumage
Encendido

DOLMAR

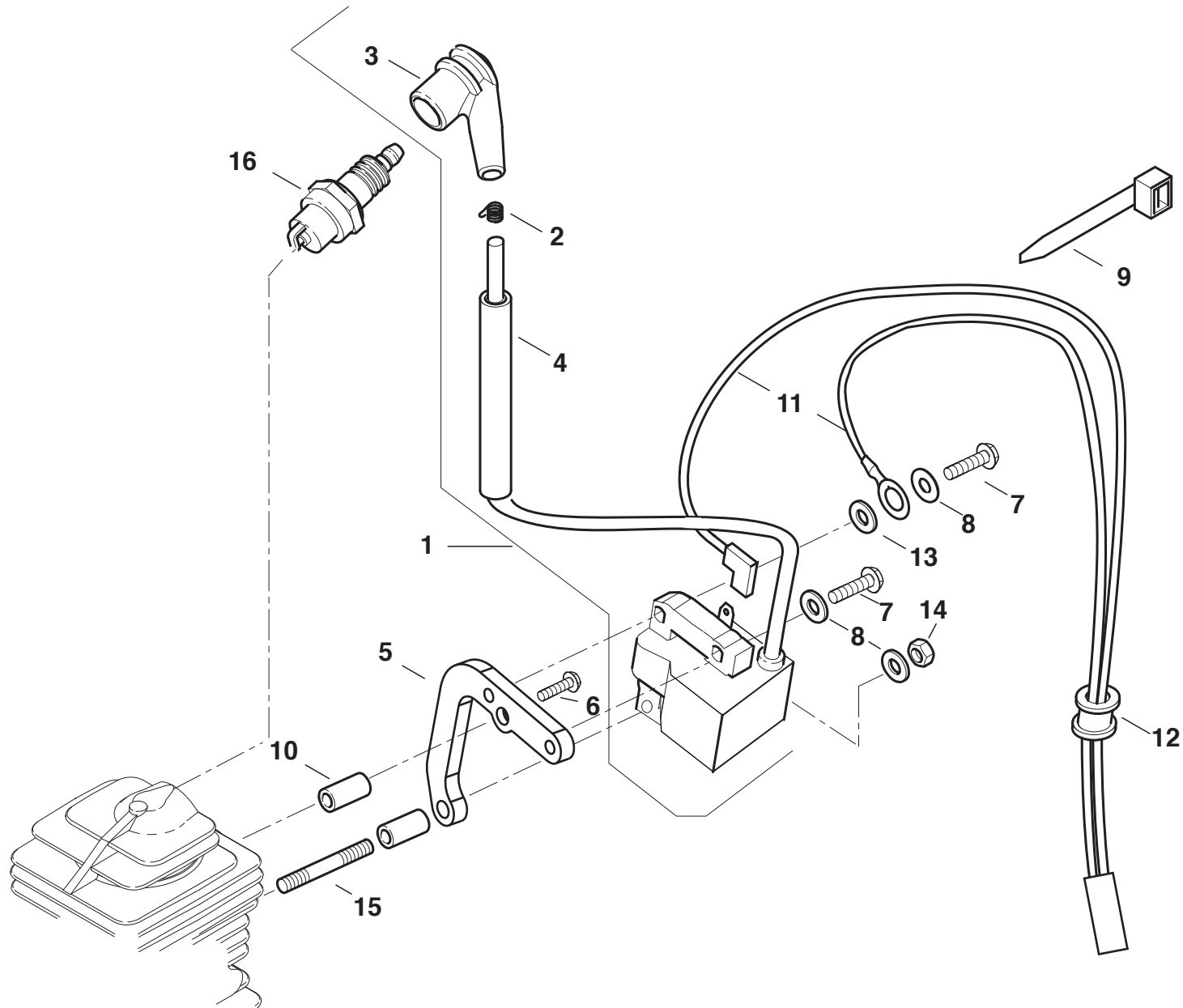

**HT-245, 255
HT-2950, 2960, 2975**



Seite / Page	Pos.	HT-245	HT-255	HT-2950	HT-2960	HT-2975	Teil-Nr. Part No. No. de pièce No. de pieza	Hinweise Notes Renseign. Nota	Bezeichnung	Spezifikation Specification	Description	Désignation	Denominación
3	1	1	1	1	1	1	302 300 840		Zündmodul		Ignition coil	Volant électronique	Bobina
3	2	1	1	1	1	1	300 073 347		Kontaktfeder		Contact spring	Ressort de contact	Resorte
3	3	1	1	1	1	1	300 084 621		Zündkerzenstecker		Spark plug cover	Capuchon de bougie	Tapa de bujia
3	4	m	m	m	m	m	300 064 292		Schlauch	95 mm	Hose	Tuyau	Tubo
3	5	1	1	1	1	1	302 042 883		Befestigungswinkel		Angle	Manchon d'angle	Angulo
3	6	1	1	1	1	1	300 013 284		Linsenschraube	4x25	Screw	Vis	Tornillo
3	7	2	2	2	2	2	300 018 280		Zylinderschraube	M4x12	Screw	Vis	Tornillo
3	8	3	3	3	3	3	300 072 148		Sicherungsscheibe		Safety washer	Rondelle	Arandela
3	9	1	1	1	1	1	300 066 455		Kabelband	98x2,5	Cable band	Frein de câble	Cinta
3	10	2	2	2	2	2	300 033 404		Hülse	8x4,4x13	Sleeve	Douille	Casquillo
3	11	1	1	1	1	1	300 084 895		Kabel Masse/Kurzschluss		Ground cable	Câble de masse	Cable de masa
3	12	1	1	1	1	1	302 063 128		Kabeltülle		Cable fitting	Oeillet	Manguito de cable
3	13	1	1	1	1	1	300 030 101		Scheibe	4,3	Washer	Rondelle	Arandela
3	14	1	1	1	1	1	300 028 118		Sechskantmutter	M4	Hex. nut	Ecrou	Tuerca
3	15	1	1	1	1	1	300 015 299		Stiftschraube	M4x35	Stud screw	Goujon	Tornillo
3	16	1	1	1	1	1	965 603 014		Zündkerze	WSR-6F	Spark plug	Bougie	Bujia

HT-245
HT-255
HT-2950
HT-2960
HT-2975

4

Benzintank
Fuel tank
Réservoir à essence
Deposito

DOLMAR
■■■■■■■■■■

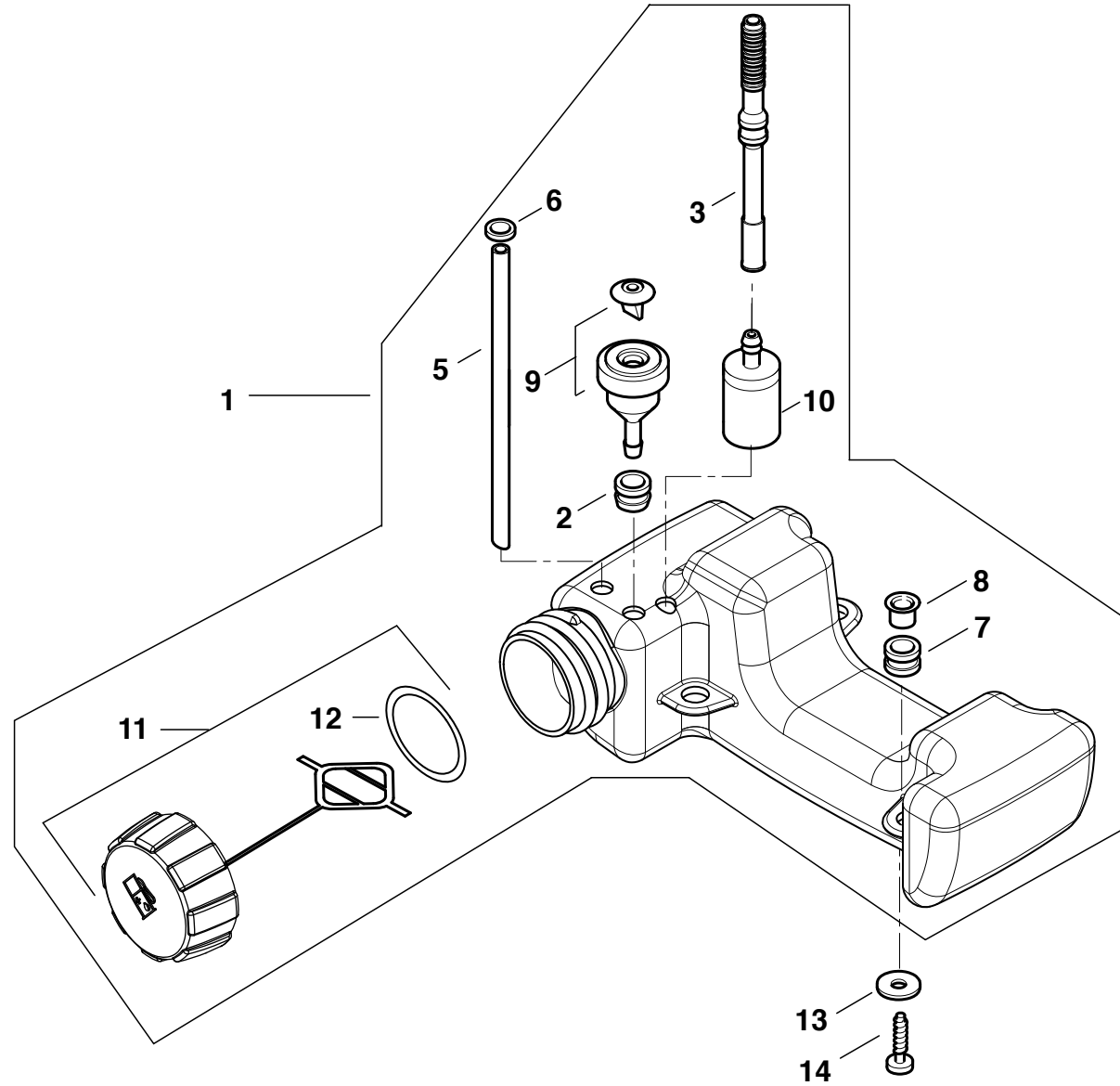

**HT-245, 255
HT-2950, 2960, 2975**



Seite / Page	Pos.	HT-245	HT-255	HT-2950	HT-2960	HT-2975	Teil-Nr. Part No. No. de pièce No. de pieza	Hinweise Notes Renseign. Nota	Bezeichnung	Spezifikation Specification	Description	Désignation	Denominación
4	1	1	1	1	1	1	302 700 150		Benzintank		Fuel tank	Réservoir à essence	Deposito
4	2	1	1	1	1	1	308 063 247		Tülle		Hose fitting	Oeillet	Manguito de cable
4	3	1	1	1	1	1	306 063 345		Schlauch Kraftstoff	3x159,5	Fuel hose	Tuyau	Tubo
4	5	1	1	1	1	1	300 064 430		Schlauch Primerrücklauf	3x1,5x230	Hose	Tuyau	Tubo
4	6	1	1	1	1	1	306 063 301		Gummiring	5x25x20	Ring	Bague de retient	Anillo
4	7	4	4	4	4	4	300 094 197		Dämpfungsgummi		AV element	Amortisseur	Elemento AV
4	8	4	4	4	4	4	300 044 285		Rohrnieten	8x0,75x7	Rivet	Rivet	Remache
4	9	1	1	1	1	1	302 700 430		Entlüftungsstutzen		Ventilation socket	Manchon d'aération	Munon
4	10	1	1	1	1	1	302 700 133		Filter Benzinsucher		Fuel pick-up	Crépine d'essence	Filtro
4	11	1	1	1	1	1	302 700 185		Tankverschluss		Tank cap	Bouchon de réservoir	Cierre de deposito
4	12	1	1	1	1	1	300 062 345		O-Ring	29x4	O-ring	Joint torique	Anillo de guarnición
4	13	4	4	4	4	4	300 030 102		Scheibe	5,3	Washer	Rondelle	Arandela
4	14	4	4	4	4	4	300 018 363		Linsenschraube	5x20	Screw	Vis	Tornillo

HT-245
HT-255
HT-2950
HT-2960
HT-2975

5

Anwerfvorrichtung
Starter
Dispositif de démarrage
Dispositivo de arranque

DOLMAR
■■■■■■■■■■

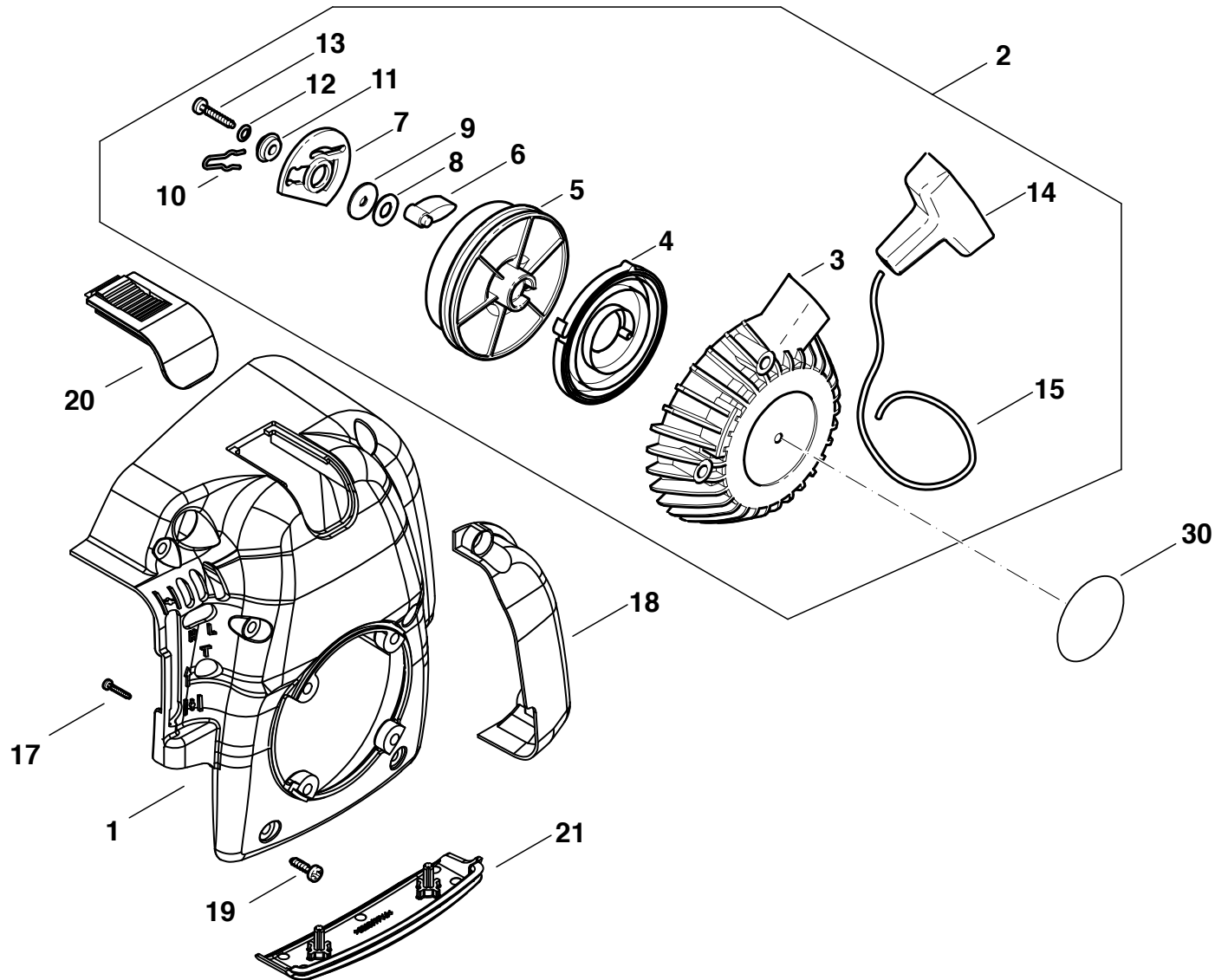

**HT-245, 255
HT-2950, 2960, 2975**



Seite / Page	Pos.	HT-245	HT-255	HT-2950	HT-2960	HT-2975	Teil-Nr. Part No. No. de pièce No. de pieza	Hinweise Notes Renseign. Nota	Bezeichnung	Spezifikation Specification	Description	Désignation	Denominación
5	1	1	1	1	1	1	307 316 048		Lüfterdeckel ohne Starter		Fan cover w/o starter	Capuchon sans carter lanceur	Cubierta sin arranque
5	2	1	1	1	1	1	302 600 140		Starter-Universal		Starter	Lanceur	Arranque
5	3	1	1	1	1	1	302 100 126		Startergehäuse		Starter housing	Carter lanceur	Caja de arranque
5	4	1	1	1	1	1	302 600 284		Federkassette		Spring cassette	Cassette de ressort	Cassette
5	5	1	1	1	1	1	307 491 525		Seilrolle		Rope pulley	Poulie de câble	Roldana
5	6	1	1	1	1	1	302 074 343		Starterklinke		Pawl	Cliquet de lanceur	Trinquete
5	7	1	1	1	1	1	307 497 725		Kulisse rot		Template	Coulisse	Colisa
5	8	1	1	1	1	1	300 030 135		Scheibe	4,3	Washer	Rondelle	Arandela
5	9	1	1	1	1	1	300 031 611		Scheibe	4,3x14,3x1	Washer	Rondelle	Arandela
5	10	1	1	1	1	1	300 073 365		Federstecker		Pin	Goupille beta	Clavija
5	11	1	1	1	1	1	302 031 965		Distanzstück	4,3x12,5x5	Spacer	Pièce d'écartement	Espaciador
5	12	1	1	1	1	1	300 034 152		Sicherungsscheibe		Safety washer	Rondelle de sécurité	Arandela
5	13	1	1	1	1	1	300 010 519		Zylinderschraube	3,5x22	Screw	Vis	Tornillo
5	14	1	1	1	1	1	302 074 570		Startergriff		Starter grip	Poignée lanceur	Empunadura
5	15	1	1	1	1	1	306 319 525		Starterseil	3x1050	Starter rope	Câble lanceur	Cuerda de arranque
5	17	4	4	4	4	4	300 018 354		Linsenschraube	4x12	Screw	Vis	Tornillo
5	18	1	1	1	1	1	304 073 163		Wärmeschutz		Thermal protector	Isolant thermique	Protector de calor
5	19	7	7	7	7	7	300 018 363		Linsenschraube	5x20	Screw	Vis	Tornillo
5	20	1	1	1	1	1	304 073 164		Zündkerzenabdeckung		Spark plug cover	Capuchon de bougie	Tapa de bujia
5	21	1	1	1	1	1	304 073 161		Gehäuseabdeckung		Cover	Carter	Tapa
5	30	1					980 115 242		Schild	HT-245	Label	Plaque	Calcomania
5	30		1				980 115 243		Schild	HT-255	Label	Plaque	Calcomania
5	30			1			980 115 244		Schild	HT-2950	Label	Plaque	Calcomania
5	30				1		980 115 245		Schild	HT-2960	Label	Plaque	Calcomania
5	30					1	980 115 246		Schild	HT-2975	Label	Plaque	Calcomania

HT-245
HT-255
HT-2950
HT-2960
HT-2975

6

Gehäuse, Handschutz
Case, hand guard
Carter, protège-main
Cárter, protector de mano

DOLMAR

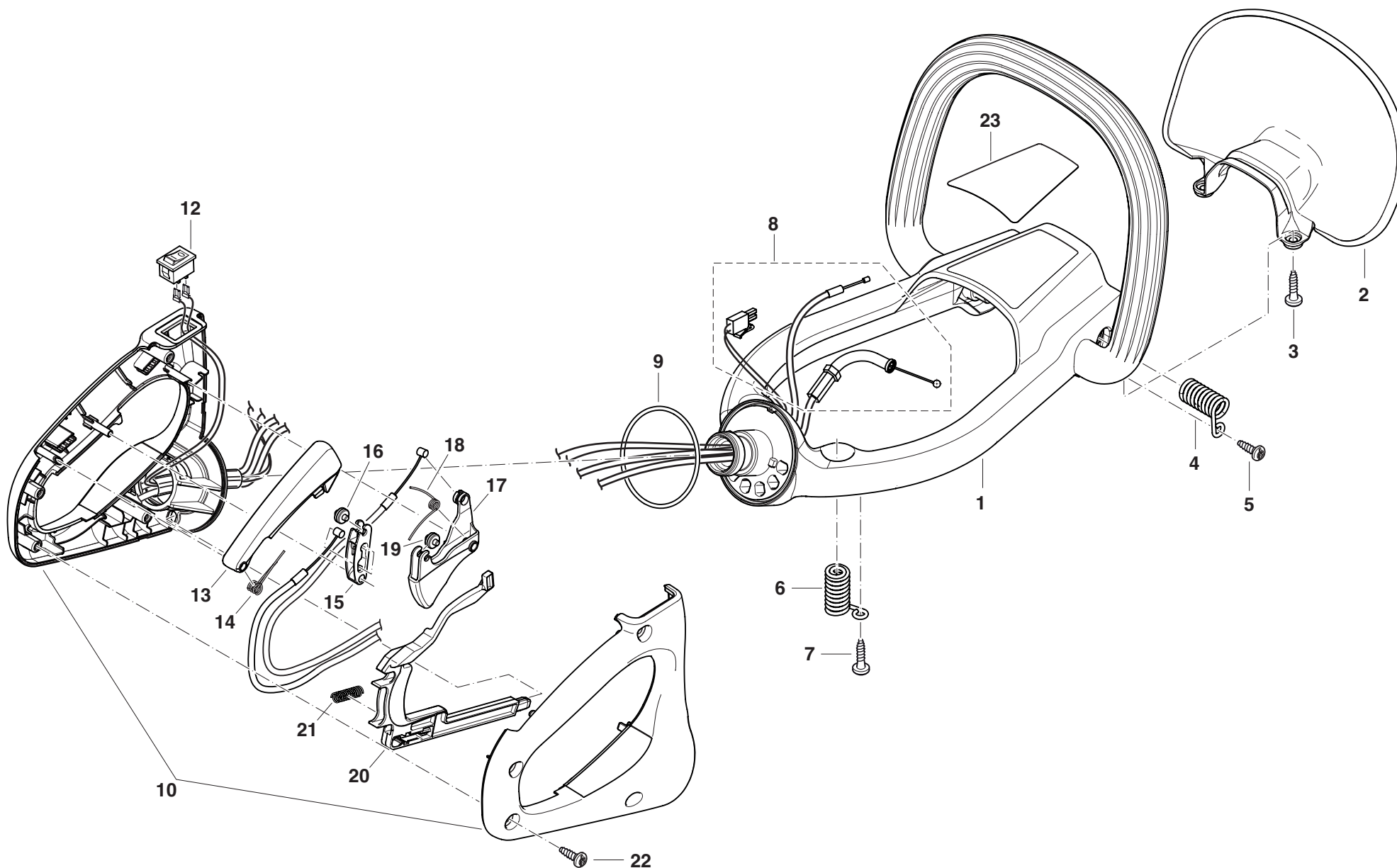

**HT-245, 255
HT-2950, 2960, 2975**



Seite / Page	Pos.	HT-245	HT-255	HT-2950	HT-2960	HT-2975	Teil-Nr. Part No. No. de pièce No. de pieza	Hinweise Notes Renseign. Nota	Bezeichnung	Spezifikation Specification	Description	Désignation	Denominación
6	1	1	1	1	1	1	342 310 011		Griffrahmen mit Bügel		Handle	Poignée	Mango
6	2	1	1	1	1	1	342 213 010		Handschutz transparent		Hand guard	Protège-main	Protector de mano
6	3	2	2	2	2	2	913 650 154		Innenstern-Schlitz-Schraube	5x15	Screw	Vis	Tornillo
6	4	2	2	2	2	2	300 073 397		Dämpfungsfeder		Spring	Ressort	Resorte
6	5	2	2	2	2	2	913 650 154		Innenstern-Schlitz-Schraube	5x15	Screw	Vis	Tornillo
6	6	2	2	2	2	2	300 073 397		Dämpfungsfeder		Spring	Ressort	Resorte
6	7	2	2	2	2	2	913 650 154		Innenstern-Schlitz-Schraube	5x15	Screw	Vis	Tornillo
6	8	1	1	1	1	1	342 312 061		Steuersatz		Control cable, set	Câble de commande, jeu	Transmis. flexible bowden, juego
6	9	1	1	1	1	1	963 262 025		O-Ring		O-ring	Joint torique	Anillo de guarnición
6	10	1	1	1	1	1	342 117 200		Griffschalen Satz		Handle, set	Poignée, jeu	Mango, juego
6	12	1	1	1	1	1	975 001 270		Geräteschalter Ein/Aus	I-0	Switch	Interrupteur	Interruptor
6	13	1	1	1	1	1	342 117 050		Sperrtaste		Catch lever	Levier de verrouillage	Palanca trincada
6	14	1	1	1	1	1	342 117 120		Schenkelfeder		Spring	Ressort	Resorte
6	15	1	1	1	1	1	342 117 070		Bremshebel		Brake lever	Levier de frein	Palanca de freno
6	16	1	1	1	1	1	342 117 090		Rolle		Roller	Galet	Rueda
6	17	1	1	1	1	1	342 117 040		Gashebel		Throttle lever	Levier d' accélération	Acelerador
6	18	1	1	1	1	1	342 117 120		Schenkelfeder		Spring	Ressort	Resorte
6	19	1	1	1	1	1	342 117 090		Rolle		Roller	Galet	Rueda
6	20	1	1	1	1	1	342 117 060		Enriegelungshebel		Lockoff lever	Levier de déblocage	Palanca de desbloqueo
6	21	1	1	1	1	1	342 117 130		Druckfeder		Spring	Ressort	Resorte
6	22	4	4	4	4	4	913 650 154		Innenstern-Schlitz-Schraube	5x15	Screw	Vis	Tornillo
6	23	1	1	1	1	1	980 115 241		Schild Bedienhinweise		Label	Plaque	Calcomania

HT-245
HT-255
HT-2950
HT-2960
HT-2975

7

Getriebe
Gear
Engrenage
Engranaje

DOLMAR

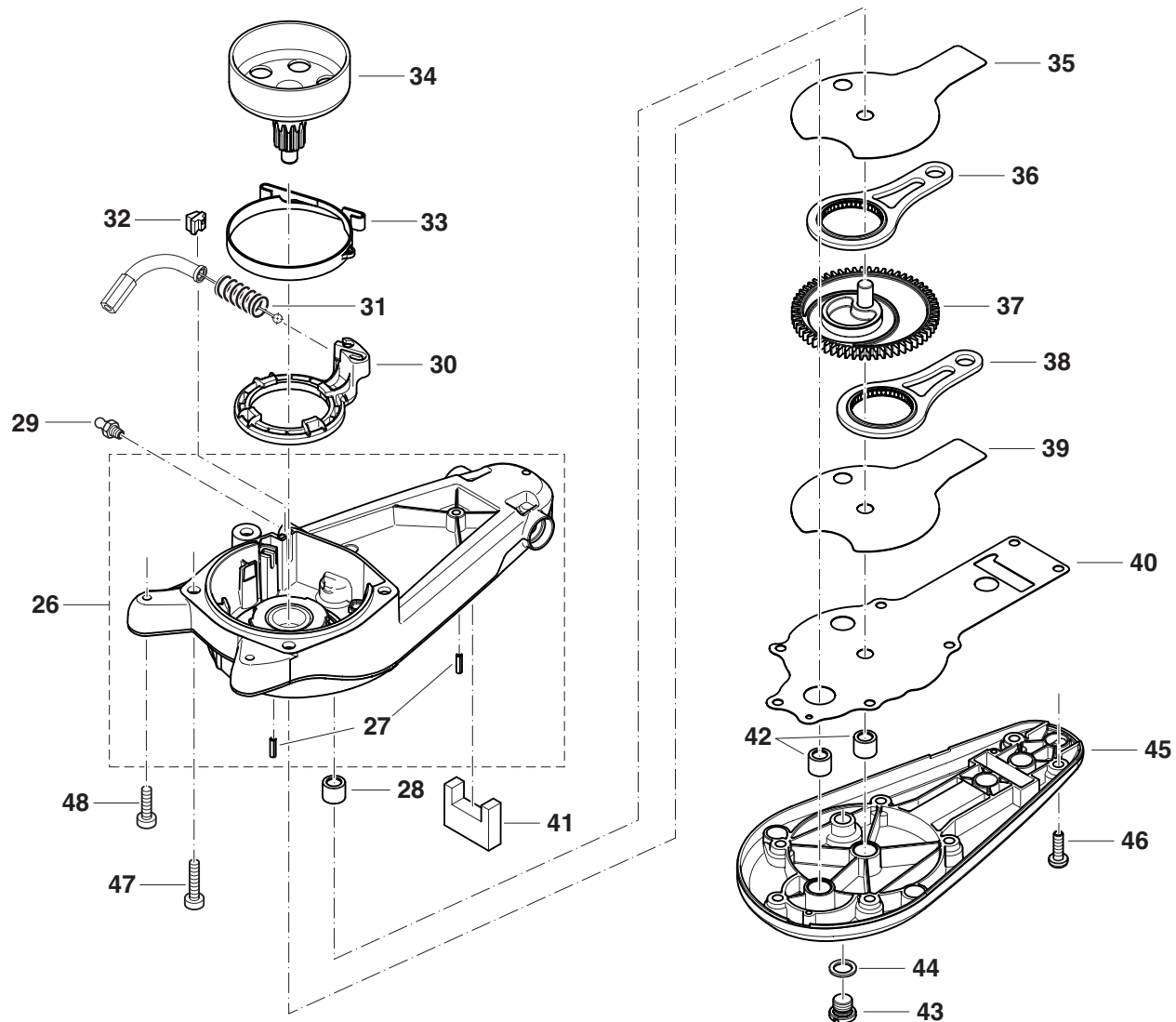

HT-245, 255
HT-2950, 2960, 2975



Seite / Page	Pos.	HT-245	HT-255	HT-2950	HT-2960	HT-2975	Teil-Nr. Part No. No. de pièce No. de pieza	Hinweise Notes Renseign. Nota	Bezeichnung	Spezifikation Specification	Description	Désignation	Denominación
7	26	1	1	1	1	1	342 200 020		Getriebegehäuse		Housing	Carter	Cárter
7	27	2	2	2	2	2	936 430 160		Spiralspannstift	3x16	Spiral clamping pin	Goupille a spirale de ten	Pasador
7	28	1	1	1	1	1	962 300 005		Nadelhülse		Needle cage	Cage a aiguilles	Jaula de agujas
7	29	1	1	1	1	1	342 211 060		Schmiernippel		Grease nipple	Nipple de graissage	Boquilla de engrase
7	30	1	1	1	1	1	342 213 020		Bremsbandhalter		Holder	Support	Soporte
7	31	1	1	1	1	1	342 213 050		Druckfeder		Spring	Ressort	Resorte
7	32	1	1	1	1	1	342 312 030		Niederhalter		Depressor	Serre-flan	Sujetador
7	33	1	1	1	1	1	342 213 040		Bremsband		Brake spring	Ressort de frein	Cinta de freno
7	34	1	1	1	1	1	342 223 030		Kupplungsglocke kpl.		Clutch drum cpl.	Tambour cpl.	Tambor cpl.
7	35	1	1	1	1	1	342 211 050		Abdeckblech		Cover	Couvercle	Cubierta
7	36	1	1	1	1	1	342 221 060		Pleuel kpl.		Con-rod cpl.	Bielle cpl.	Biela cpl.
7	37	1	1	1	1	1	342 229 010		Zahnrad kpl.		Gear	Roue dentée	Rueda dentada
7	38	1	1	1	1	1	342 221 060		Pleuel kpl.		Con-rod cpl.	Bielle cpl.	Biela cpl.
7	39	1	1	1	1	1	342 211 050		Abdeckblech		Cover	Couvercle	Cubierta
7	40	1	1	1	1	1	342 211 150		Dichtung		Gasket	Joint	Junta
7	41	1	1	1	1	1	342 211 140		Filzdichtung		Gasket	Joint	Junta
7	42	2	2	2	2	2	962 300 005		Nadelhülse		Needle cage	Cage a aiguilles	Jaula de agujas
7	43	1	1	1	1	1	342 211 080		Verschlusschraube		Cap	Bouchon	Tope de cierre
7	44	1	1	1	1	1	963 110 130		Dichtscheibe		Gasket	Joint	Junta
7	45	1	1	1	1	1	342 211 110		Getriebegehäusedeckel kpl.		Cover	Couvercle	Cubierta
7	46	7	7	7	7	7	908 905 165		Schraube	5x16	Screw	Vis	Tornillo
7	47	4	4	4	4	4	913 660 204		Innenstern-Schraube	6x20	Screw	Vis	Tornillo
7	48	4	4	4	4	4	908 905 165		Zylinderschraube	5x16	Screw	Vis	Tornillo

HT-245
HT-255
HT-2950
HT-2960
HT-2975

8

Scherblatt
Shear blade
Lame
Cuchilla de corte

DOLMAR

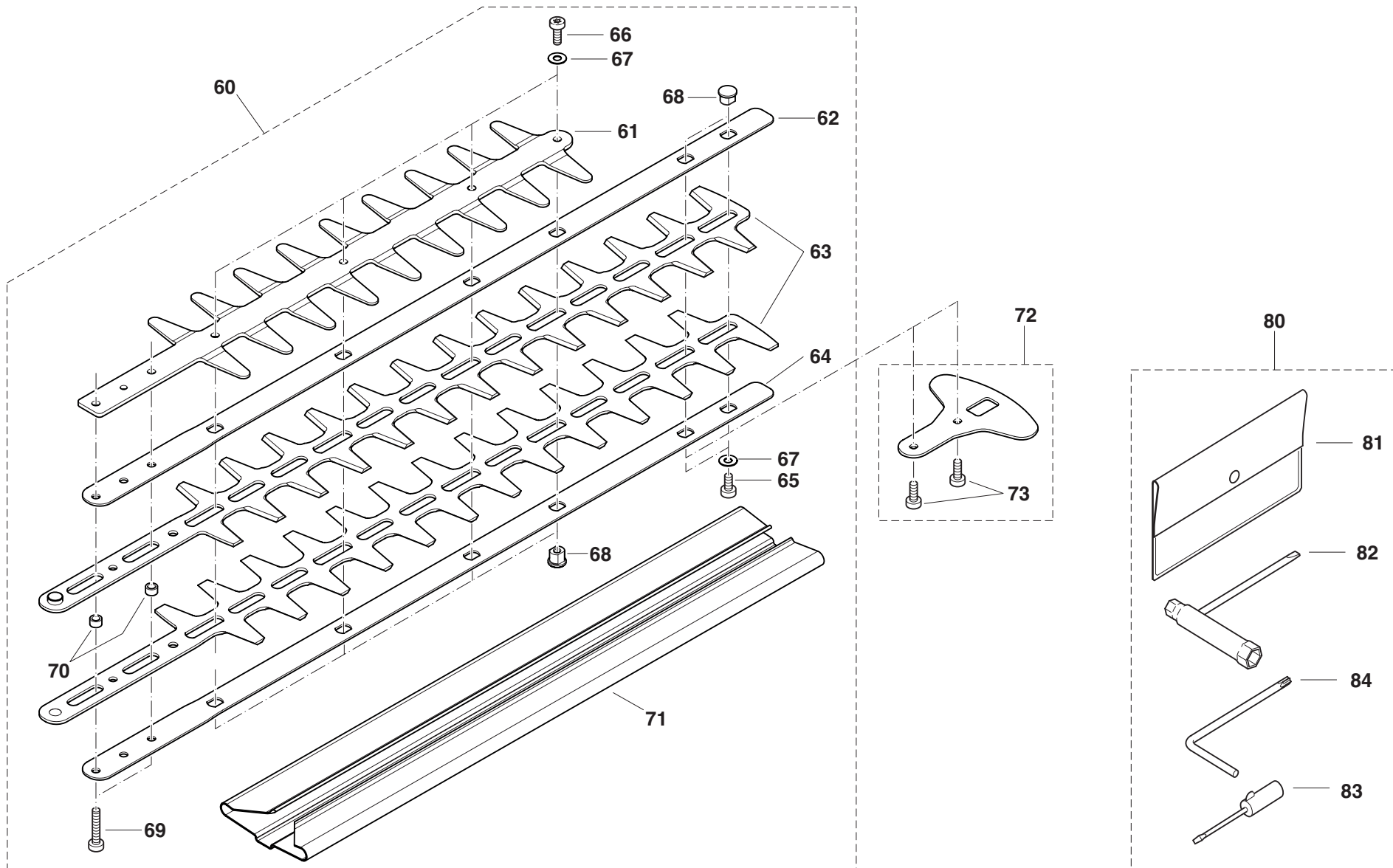

**HT-245, 255
HT-2950, 2960, 2975**



Seite / Page	Pos.	HT-245	HT-255	HT-2950	HT-2960	HT-2975	Teil-Nr. Part No. No. de pièce No. de pieza	Hinweise Notes Renseign. Nota	Bezeichnung	Spezifikation Specification	Description	Désignation	Denominación
8	60			1			342 230 050		Messer kpl. mit Schutz	50cm	Shear blade cpl.	Lame cpl.	Cuchilla de corte cpl.
8	60				1		342 230 060		Messer kpl. mit Schutz	60cm	Shear blade cpl.	Lame cpl.	Cuchilla de corte cpl.
8	60					1	342 230 070		Messer kpl. mit Schutz	75cm	Shear blade cpl.	Lame cpl.	Cuchilla de corte cpl.
8	60			1			342 230 250		Messer kpl. mit Schutz	50cm - USA	Shear blade cpl.	Lame cpl.	Cuchilla de corte cpl.
8	60				1		342 230 260		Messer kpl. mit Schutz	60cm - USA	Shear blade cpl.	Lame cpl.	Cuchilla de corte cpl.
8	60					1	342 230 270		Messer kpl. mit Schutz	75cm - USA	Shear blade cpl.	Lame cpl.	Cuchilla de corte cpl.
8	61			1	1	1	342 233 010		Kamm		Blade guard	Barre de protection	Barra de protección
8	61			1	1	1	342 233 020		Kamm	USA	Blade guard	Barre de protection	Barra de protección
8	62			1			342 233 250		Gleitschiene gerade	50cm	Bar	Barre	Listón
8	62				1		342 233 270		Gleitschiene gerade	60cm	Bar	Barre	Listón
8	62					1	342 233 290		Gleitschiene gerade	75cm	Bar	Barre	Listón
8	63			2			342 233 050		Scherplatte	50cm	Shear plate	Plaque de coupe	Barra de corte
8	63				2		342 233 060		Scherplatte	60cm	Shear plate	Plaque de coupe	Barra de corte
8	63					2	342 233 070		Scherplatte	75cm	Shear plate	Plaque de coupe	Barra de corte
8	64			1			342 233 240		Gleitschiene gebogen	50cm	Bar	Barre	Listón
8	64				1		342 233 260		Gleitschiene gebogen	60cm	Bar	Barre	Listón
8	64					1	342 233 280		Gleitschiene gebogen	75cm	Bar	Barre	Listón
8	65			2	3	4	908 005 095		Innenstern-Schraube	5x9	Screw	Vis	Tornillo
8	66			4	4	4	908 005 125		Innenstern-Schraube	5x12	Screw	Vis	Tornillo
8	67			6	7	8	928 505 000		Spannscheibe		Spring washer	Rondelle elastique	Arandela elástica
8	68			6	7	8	342 233 230		Distanzmutter		Nut	Ecrou	Tuerca
8	69			2	2	2	908 005 255		Innenstern-Schraube	5x25	Screw	Vis	Tornillo
8	70			2	2	2	342 233 220		Distanzring		Ring	Bague	Anillo
8	71			1			342 233 350		Messerschutz	50cm	Sheath	Carquois de protection	Carcaj de conservacion
8	71				1		342 233 360		Messerschutz	60cm	Sheath	Carquois de protection	Carcaj de conservacion
8	71					1	342 233 370		Messerschutz	75cm	Sheath	Carquois de protection	Carcaj de conservacion
8	72			1	1	1	957 342 020		Stoßschutz kpl.		Guard	Protecteur	Protector
8	73			2	2	2	908 005 125		Innenstern-Schraube	5x12	Screw	Vis	Tornillo
8	80			1	1	1	957 004 006		Werkzeugsatz		Tool cpl.	Outils cpl.	Herramientas cpl.
8	81			1	1	1	950 004 002		Werkzeugtasche		Plastic bag	Pochette en plastique	Cartera herramientas
8	82			1	1	1	941 719 140		Kombischlüssel	13/19	Universal wrench	Clé combinée	Llave de bujía
8	83			1	1	1	944 340 001		Schraubendreher		Screw driver	Tournevis	Destornillador
8	84			1	1	1	940 827 000		Winkelschraubendreher		Angled screw driver	Clé angle	Llave angular

HT-245
HT-255
HT-2950
HT-2960
HT-2975

9

Scherblatt
Shear blade
Lame
Cuchilla de corte

DOLMAR
■■■■■■■■■■

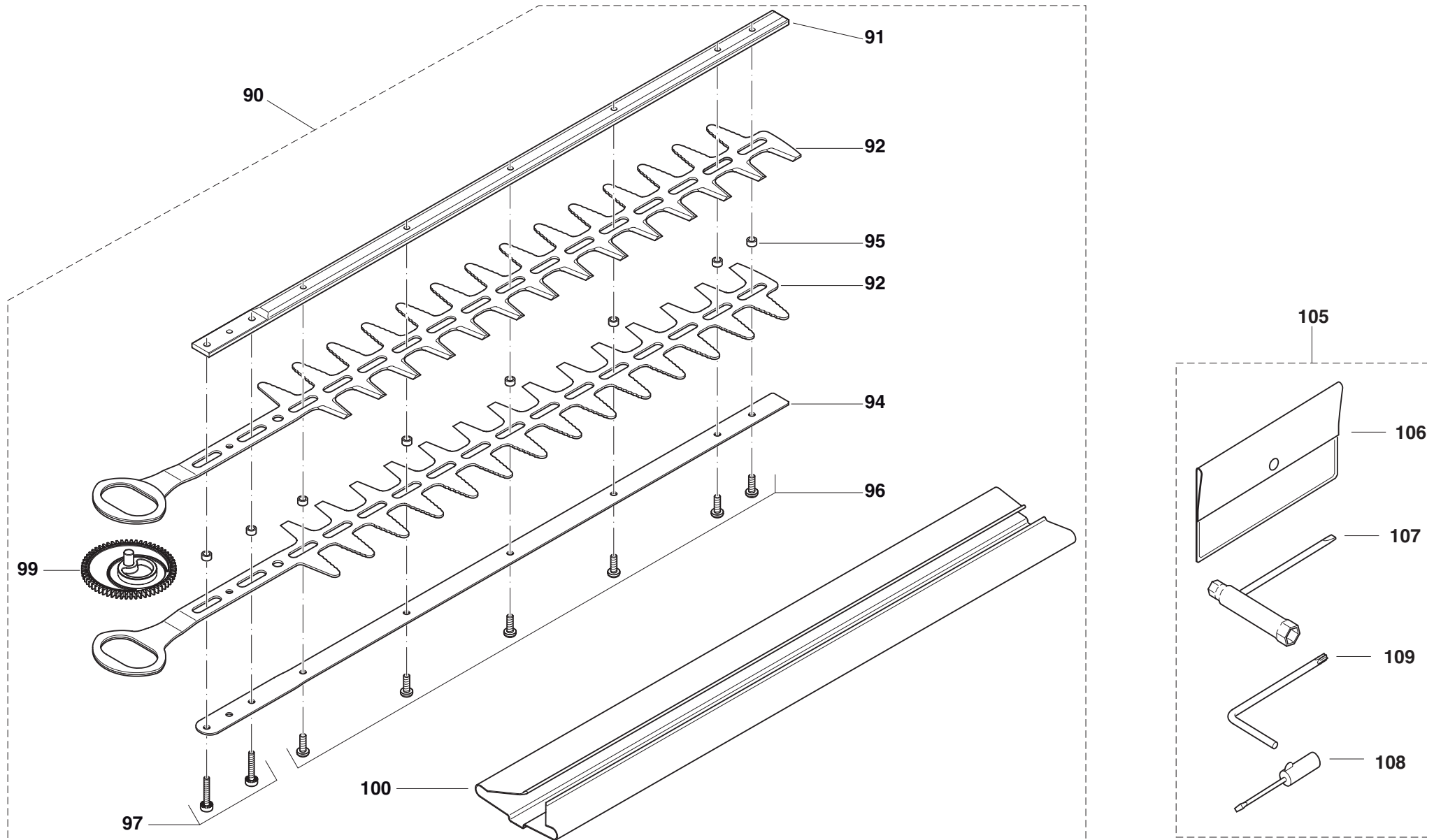

**HT-245, 255
HT-2950, 2960, 2975**



Seite / Page	Pos.	HT-245	HT-255	HT-2950	HT-2960	HT-2975	Teil-Nr. Part No. No. de pièce No. de pieza	Hinweise Notes Renseign. Nota	Bezeichnung	Spezifikation Specification	Description	Désignation	Denominación
9	90	1					341 230 040		Messer kpl. mit Schutz	45cm	Shear blade cpl.	Lame cpl.	Cuchilla de corte cpl.
9	90		1				341 230 050		Messer kpl. mit Schutz	55cm	Shear blade cpl.	Lame cpl.	Cuchilla de corte cpl.
9	90	1					341 230 240		Messer kpl. mit Schutz	45cm - USA	Shear blade cpl.	Lame cpl.	Cuchilla de corte cpl.
9	90		1				341 230 250		Messer kpl. mit Schutz	55cm - USA	Shear blade cpl.	Lame cpl.	Cuchilla de corte cpl.
9	91	1					341 233 010		Aufspannleiste	45cm	Mounting bar	Barre de serrage	Barre de montage
9	91		1				341 233 020		Aufspannleiste	55cm	Mounting bar	Barre de serrage	Barre de montage
9	91	1					341 233 210		Aufspannleiste	45cm - USA	Mounting bar	Barre de serrage	Barre de montage
9	91		1				341 233 230		Aufspannleiste	55cm - USA	Mounting bar	Barre de serrage	Barre de montage
9	92	2					341 233 040		Scherplatte gebogen	45cm	Shear plate	Plaque de coupe	Barra de corte
9	92		2				341 233 050		Scherplatte gebogen	55cm	Shear plate	Plaque de coupe	Barra de corte
9	94	1					341 233 140		Gleitschiene gebogen	45cm	Bar	Barre	Listón
9	94		1				341 233 150		Gleitschiene gebogen	55cm	Bar	Barre	Listón
9	95	8	8				341 233 220		Distanzring		Ring	Bague	Anillo
9	96	6	6				908 905 165		Zylinderschraube	5x16	Screw	Vis	Tornillo
9	97	2	2				908 705 255		Innenstern-Schraube	5x25	Screw	Vis	Tornillo
9	99	1	1				342 229 010		Zahnrad kpl.		Gear wheel cpl.	Roue dentée	Piñon
9	100	1					341 233 340		Messerschutz	45cm	Sheath	Carquois de protection	Carcaj de conservacion
9	100		1				341 233 350		Messerschutz	55cm	Sheath	Carquois de protection	Carcaj de conservacion
9	105	1	1				957 004 006		Werkzeugsatz		Tool cpl.	Outils cpl.	Herramientas cpl.
9	106	1	1				950 004 002		Werkzeugtasche		Plastic bag	Pochette en plastique	Cartera herramientas
9	107	1	1				941 719 140		Kombischlüssel	13/19	Universal wrench	Clé combinée	Llave de bujía
9	108	1	1				944 340 001		Schraubendreher		Screw driver	Tournevis	Destornillador
9	109	1	1				940 827 000		Winkelschraubendreher		Angled screw driver	Clé angle	Llave angular

HT-245
HT-255
HT-2950
HT-2960
HT-2975

Inhaltsverzeichnis
Index
Table des matières
Indice

DOLMAR



1	Motor, Kurbelwelle	Motor, ckrankshaft	Moteur, villebrequin	Motor, cigüeñal
2	Luftfilter, Vergaser, Schalldämpfer	Air filter, carburetor, muffler	Filtre à air, carburateur, pot d' échappement	Filtro de aire, carburador, silencioso
3	Zündung	Ignition	Allumage	Encendido
4	Benzintank	Fuel tank	Réservoir à essence	Deposito
5	Anwerfvorrichtung	Starter	Dispositif de démarrage	Dispositivo de arranque
6	Gehäuse, Handschutz	Case, hand guard	Carter, protégé-main	Cárter, protector de mano
7	Getriebe	Gear	Engrenage	Engranaje
8	Scherblatt	Shear blade	Lame	Cuchilla de corte
9	Scherblatt	Shear blade	Lame	Cuchilla de corte

	Zeichenerklärung	Key to symbols	Légende	Explicación de símbolos
<p>⇒ 1999999 2000000 ⇒ 2003.04 ⇒ TI 2003/07 Acc. = { m Corr.</p>	<p>Produktion bis Serien-Nr. Neues Teil ab Serien-Nr. Neues Teil ab Jahr / Monat Siehe Technische Information Jahr / Nr. Zubehör (nicht im Lieferumfang) Keine Serienausführung, jedoch verwendbar Beinhaltet Positions-Nr. Meterware Druckfehlerberichtigung</p>	<p>Production to serial number New part from serial number New part from Year / Month See Technical Information Year / No. Accessories (not included in the delivery inventory) No standard execution, may be used Contains item number Sold by the meter Error correction</p>	<p>Production jusqu'à n° de série Nouveau pièce à partir du n° de série Nouveau pièce à partir de année / mois Voir information technique année / n° Accessoires (non compris dans la livraison) Aucune exécut. en série, cependant utilisable contient n° de numéro Au mètre Rectification d' erreurs</p>	<p>Producción hasta N° de serie Pieza nueva a partir de N° de serie Pieza nueva a partir de año / mes Véase inform. técnico año / N° Accesorios (no incluido en la extensión del suministro) No es de serie, pero sirve Contiene pos N° Por metro Fe de erratas</p>
	Änderungen vorbehalten	Specifications subject to change without notice	Changements sanas préavis	Mejoras constructivas sin previo aviso