

Ersatzteilliste
Spare Parts List
Liste de pièces détachées
Lista de piezas de repuesto

2004-11

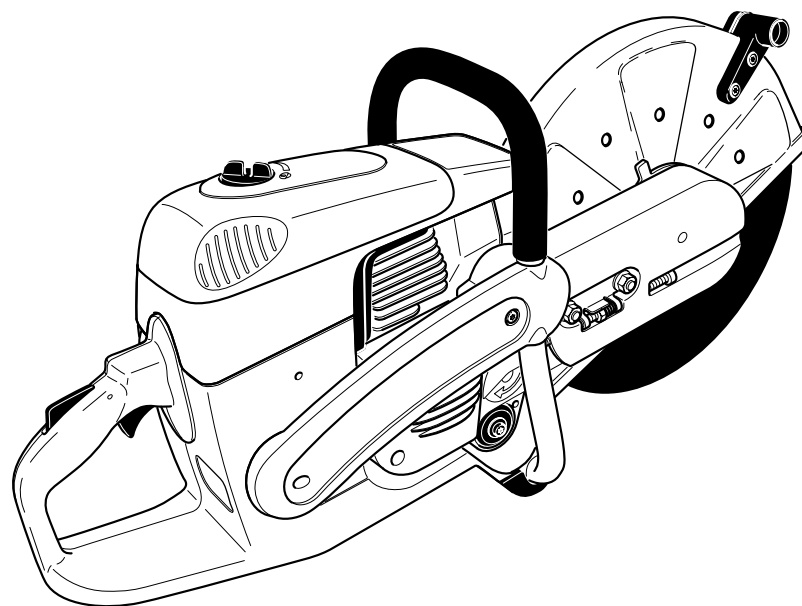

PC-6412 S
PC-6414 S
PC-7312 S
PC-7314 S

PC-6430
PC-6435
PC-7330
PC-7335

DOLMAR



A member of the *Makita* Group

995 700 081 (D, GB, F, E)

PC-6412 S PC-6430
 PC-6414 S PC-6435
 PC-7312 S PC-7330
 PC-7314 S PC-7335

1

Tankeinheit und Handgriffe
 Tank and handle grips
 Réservoir et poignées
 Depósito y mangos

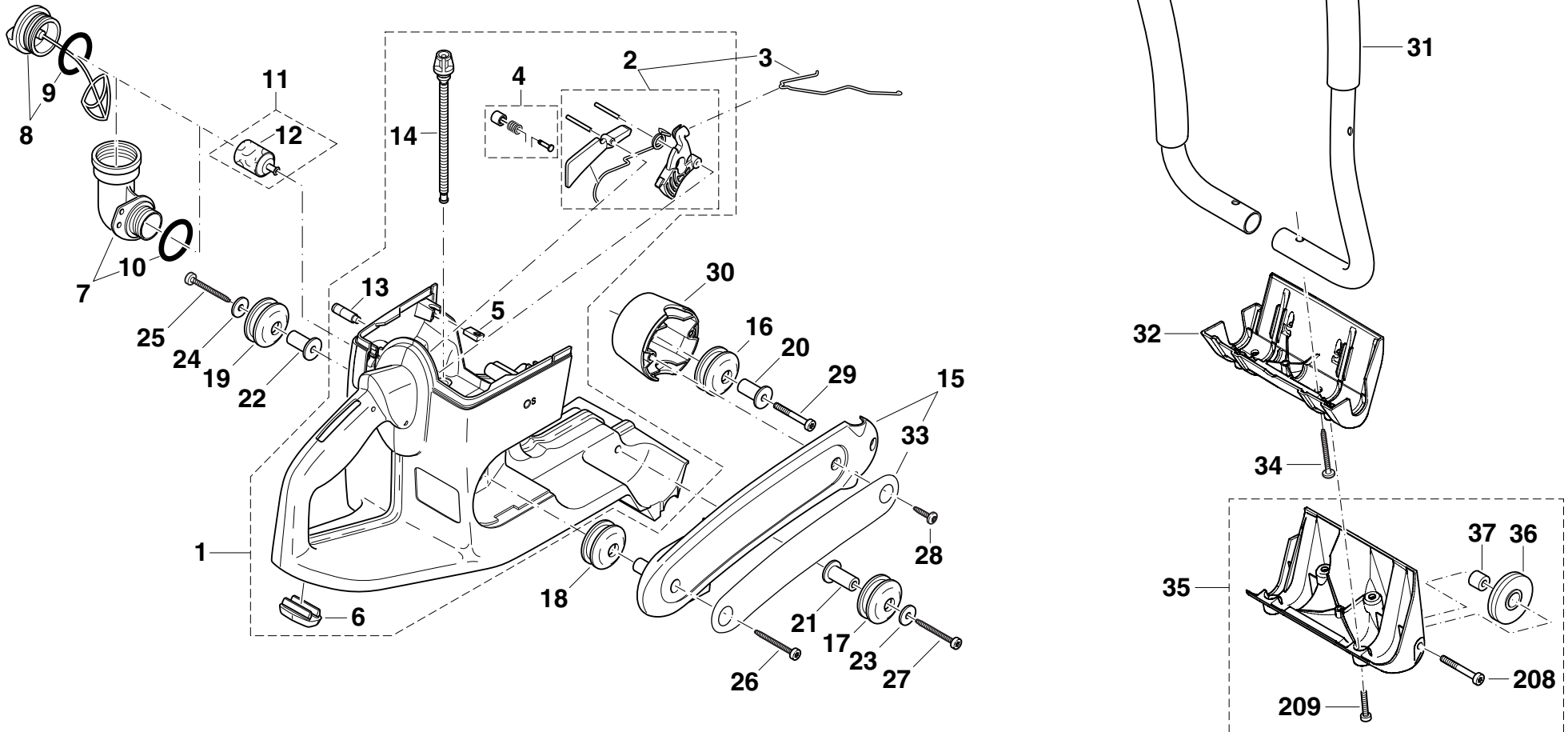

PC-6412 S, 6414 S, 7312 S, 7314 S
PC-6430, 6435, 7330, 7335



Seite / Page	Pos.	PC-6412 S int.	PC-6414 S int.	PC-7312 S int.	PC-7314 S int.	PC-6412 S U.K.	PC-7314 S U.K.	PC-6430 U.S.A.	PC-6435 U.S.A.	PC-7330 U.S.A.	PC-7335 U.S.A.	Teil-Nr. Part No. No. de pièce No. de pieza	Hinweise Notes Renseign. Nota	Bezeichnung	Spezifikation Specification	Description	Désignation	Denominación
1	1	1	1	1	1	1	1	1	1	1	1	394 114 004		Tank kpl. mit Mechanik, rot		Tank cpl., red	Réservoir cpl., rouge	Depósito cpl., rojo
1	2	1	1	1	1	1	1	1	1	1	1	957 117 020		Gasmechanik kpl.		Throttle mechanism, cpl.	Mécanique de déclenche. cpl.	Mecanismo acelerador, cpl.
1	3	1	1	1	1	1	1	1	1	1	1	394 117 011		Gasgestänge		Throttle linkage	Tringle d' accélération	Varilla acelerador
1	4	1	1	1	1	1	1	1	1	1	1	957 117 030		Halbgasarretierung kpl.		Half-throttle lock, cpl.	Dispos. d'arrêt demi-gaz cpl.	Bloqueo medio gas, cpl.
1	5	4	4	4	4	4	4	4	4	4	4	394 114 100		Schraubeinsatz		Screw plug	Embout de vissage	Alojamiento de tornillos
1	6	1	1	1	1	1	1	1	1	1	1	394 114 070		Gummifuß		Rubber foot	Pied, caotchouc	Pie, goma
1	7	1	1	1	1	1	1	1	1	1	1	010 114 081	Acc.	Winkeltankverschluß kpl.		Angular union assy.	Manchon coudé cpl.	Cierre angular cpl.
1	8	1	1	1	1	1	1	1	1	1	1	010 114 091		Tankdeckel kpl., Kraftstoff		Tank cap cpl., fuel	Bouchon réservoir cpl., carb.	Cierre depósito cpl., comb.
1	9	1	1	1	1	1	1	1	1	1	1	963 230 031		O-Ring, rot	ø30x3	O-Ring, red	Bague joint, rouge	Anillo de guarnición, rojo
1	10	1	1	1	1	1	1	1	1	1	1	963 230 031	Acc.	O-Ring, rot	ø30x3	O-Ring, red	Bague joint, rouge	Anillo de guarnición, rojo
1	11	1	1	1	1	1	1	1	1	1	1	963 601 120		Saugkopf		Suction head	Tête d' aspiration	Cabeza de aspiración
1	12	1	1	1	1	1	1	1	1	1	1	963 601 240		Filz		Felt	Feutre	Filtro
1	13	1	1	1	1	1	1	1	1	1	1	010 175 050		Belüftungsventil kpl.		Air valve cpl.	Soupape d' aeration cpl.	Válvula ventilacion cpl.
1	14	1	1	1	1	1	1	1	1	1	1	965 404 911		Saugschlauch Kraftstoff		Fuel line	Conduite carb.	Tube comb.
1	15	1	1	1	1	1	1	1	1	1	1	394 114 181		Seitenstrebe, schwarz	DOLMAR	Bracket, black	Support, noir	Soporte, negro
1	16	1	1	1	1	1	1	1	1	1	1	965 403 532		Schwingungsdämpfer		Rubber buffer	Amortisseur	Amortiguador
1	17	1	1	1	1	1	1	1	1	1	1	965 403 532		Schwingungsdämpfer		Rubber buffer	Amortisseur	Amortiguador
1	18	1	1	1	1	1	1	1	1	1	1	965 403 532		Schwingungsdämpfer		Rubber buffer	Amortisseur	Amortiguador
1	19	1	1	1	1	1	1	1	1	1	1	965 403 532		Schwingungsdämpfer		Rubber buffer	Amortisseur	Amortiguador
1	20	1	1	1	1	1	1	1	1	1	1	394 114 031		Achse für Dämpfer		Axle	Axe	Eje
1	21	1	1	1	1	1	1	1	1	1	1	394 114 031		Achse für Dämpfer		Axle	Axe	Eje
1	22	1	1	1	1	1	1	1	1	1	1	394 114 031		Achse für Dämpfer		Axle	Axe	Eje
1	23	1	1	1	1	1	1	1	1	1	1	924 405 500		Scheibe	ø 5,5	Washer	Rondelle	Arandela
1	24	1	1	1	1	1	1	1	1	1	1	924 405 500		Scheibe	ø 5,5	Washer	Rondelle	Arandela
1	25	1	1	1	1	1	1	1	1	1	1	913 455 454		Innenstern-Schraube	5,5x45	Screw	Vis	Tornillo
1	26	1	1	1	1	1	1	1	1	1	1	913 455 454		Innenstern-Schraube	5,5x45	Screw	Vis	Tornillo
1	27	1	1	1	1	1	1	1	1	1	1	913 455 454		Innenstern-Schraube	5,5x45	Screw	Vis	Tornillo
1	28	2	2	2	2	2	2	2	2	2	2	913 455 204		Innenstern-Schraube	5,5x20	Screw	Vis	Tornillo
1	29	1	1	1	1	1	1	1	1	1	1	908 305 405		Innenstern-Schraube	M5x20x40	Screw	Vis	Tornillo
1	30	1	1	1	1	1	1	1	1	1	1	394 114 750		Aufnahmetopf für Dämpfer, schwarz		Pot, black	Capuchon, noir	Pote, negro
1	31	1	1	1	1	1	1	1	1	1	1	394 310 100		Rundumgriff kpl.		Wrap around handle	Poignée circulaire	Mango circular
1	32	1	1	1	1	1	1	1	1	1	1	394 114 190		Standfuß		Foot	Pied	Pie
1	33	1	1	1	1	1	1	1	1	1	1	980 114 987		Schild	DOLMAR	Label	Plaque	Calcomania
1	34	2	2	2	2	2	2	2	2	2	2	913 455 454		Innenstern-Schraube	5,5x45	Screw	Vis	Tornillo
1	35	1	1	1	1	1	1	1	1	1	1	394 114 270	Acc.	Standfuß mit Rollen kpl.		Foot with roller, cmpl.	Pied avec rouleaux complet	Pie con ruedas completo
1	36	2	2	2	2	2	2	2	2	2	2	394 114 230		Rolle		Roller	Rouleau	Rueda
1	37	2	2	2	2	2	2	2	2	2	2	394 114 240		Buchse		Bushing	Douille	Casquillo
1	208	2	2	2	2	2	2	2	2	2	2	908 006 355		Innenstern-Schraube	M6x35	Screw	Vis	Tornillo
1	209	4	4	4	4	4	4	4	4	4	4	913 350 164		Innenstern-Schraube	5x16	Screw	Vis	Tornillo

PC-6412 S PC-6430
PC-6414 S PC-6435
PC-7312 S PC-7330
PC-7314 S PC-7335

2

Abdeckhaube, Luftfilter
Hood, air filter
Capot, filtre à air
Cubierta, filtro de aire

DOLMAR

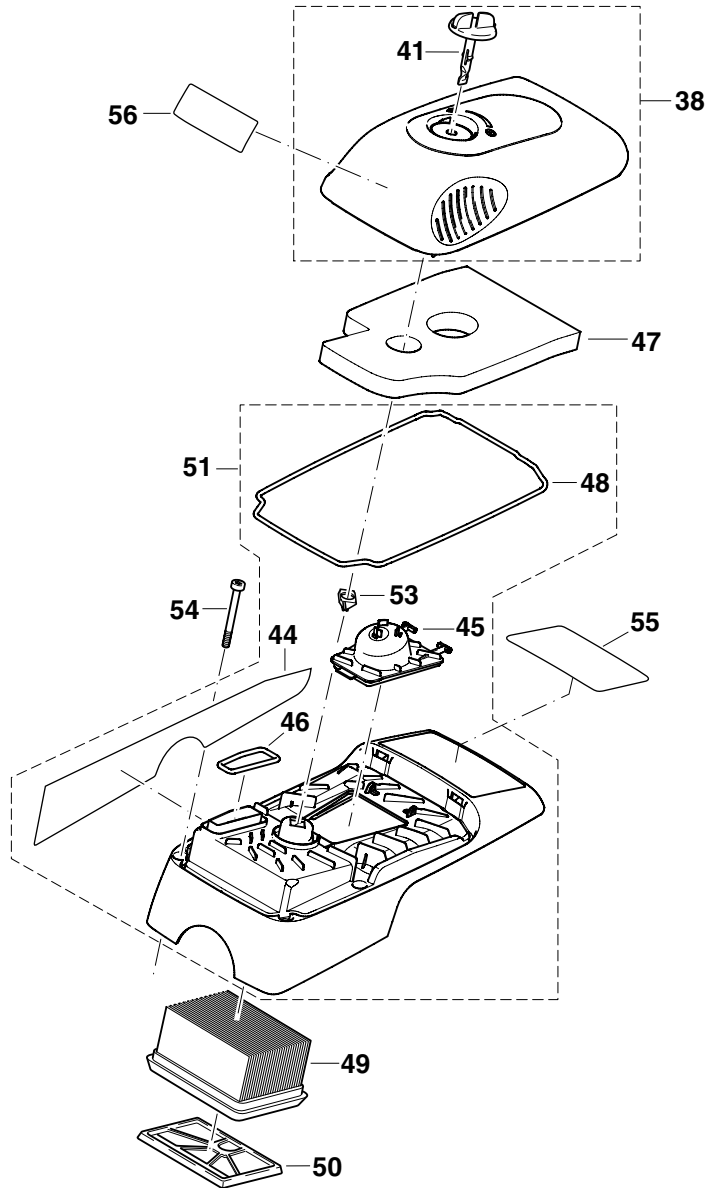

U.K.

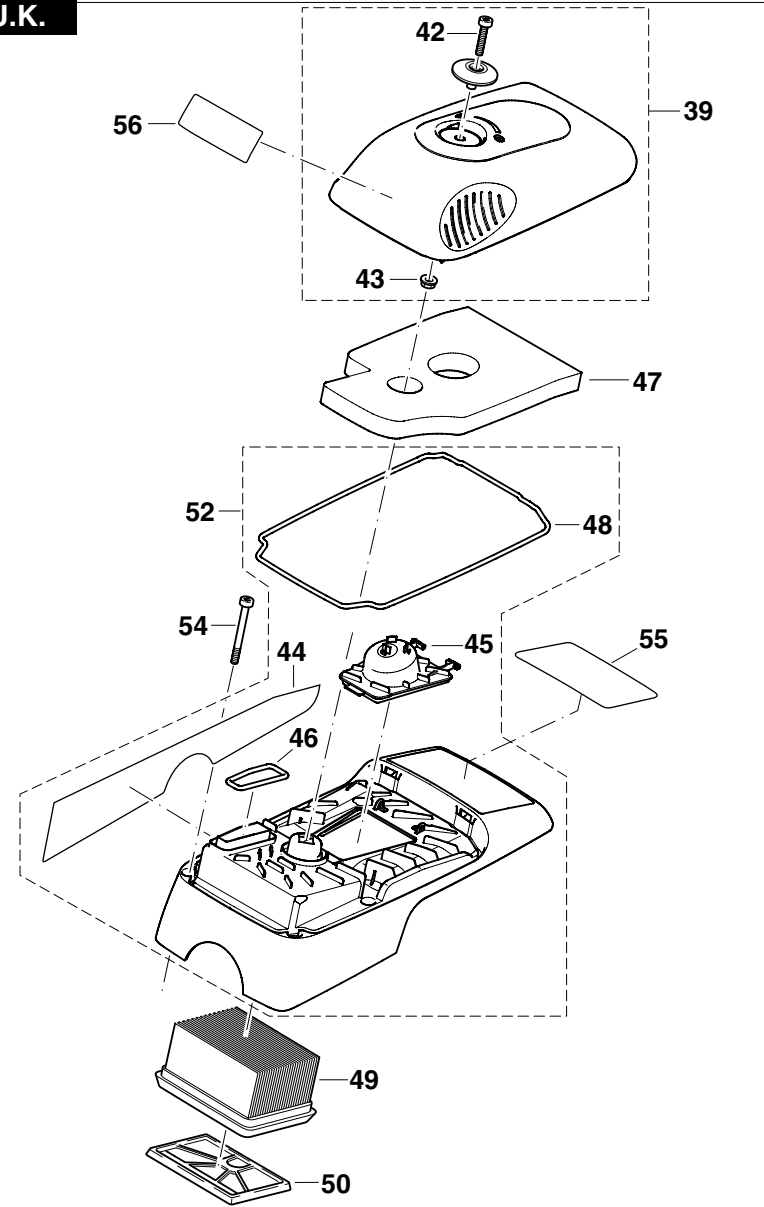

PC-6412 S, 6414 S, 7312 S, 7314 S
PC-6430, 6435, 7330, 7335



Seite / Page	Pos.	PC-6412 S int.	PC-6414 S int.	PC-7312 S int.	PC-7314 S int.	PC-6412 S U.K.	PC-7314 S U.K.	PC-6430 U.S.A.	PC-6435 U.S.A.	PC-7330 U.S.A.	PC-7335 U.S.A.	Teil-Nr. Part No. No. de pièce No. de pieza	Hinweise Notes Renseign. Nota	Bezeichnung	Spezifikation Specification	Description	Désignation	Denominación
2	38	1	1	1	1							326 118 150		Filterdeckel kpl., rot		Filter cover assy., red	Capot filtre cpl., rouge	Cubierta p. filtre cpl., rojo
2	38							1	1	1	1	326 118 510		Filterdeckel kpl., schwarz		Filter cover assy., black	Capot filtre cpl., noir	Cubierta p. filtre cpl., negro
2	39					1	1					326 118 160	U.K.	Filterdeckel kpl., rot		Filter cover assy., red	Capot filtre cpl., rouge	Cubierta para filtre cpl., rojo
2	41	1	1	1	1			1	1	1	1	394 118 010		Bajonettverschluß		Bayonet fixing	Fermeture à baïonnette	Cierre de bayoneta
2	42					1	1					908 005 305	U.K.	Innenstern-Schraube	M5x30	Screw	Vis	Tornillo
2	43					1	1					922 105 004	U.K.	6kt-Mutter	M5	Hexagonal nut	Ecrou hexagonal	Tuerca hexagonal
2	44	1	1	1	1	1	1	1	1	1	1	980 114 971		Sicherheitsaufkleber		Safety label	Plaque	Calcomania
2	45	1	1	1	1	1	1	1	1	1	1	326 118 070		Kerzendeckel		Cover for spark plug	Couvercle p. bougie	Tapa p. bujía
2	46	1	1	1	1	1	1	1	1	1	1	326 118 050		Dichtring Hauptfilter		Packing ring	Bague-joint	Anillo de guarnición
2	47	1	1	1	1	1	1	1	1	1	1	326 173 080		Vorfilter		Prefilter	Prefiltre	Primer filtro
2	48	1	1	1	1	1	1	1	1	1	1	326 118 020		Dichtring Filterdeckel		Packing ring	Bague-joint	Anillo de guarnición
2	49	1	1	1	1	1	1	1	1	1	1	394 173 010		Luftfiltereinsatz		Air filter	Filtre à air	Filtro de aire
2	50	1	1	1	1	1	1	1	1	1	1	394 173 020		Innenfilter		Inner filter	Filtre intérieur	Filtro de aire interior
2	51	1	1	1	1			1	1	1	1	326 118 080		Abdeckhaube kpl., schwarz		Hood cpl., black	Capot protection cpl., noir	Tapa protectora cpl., negro
2	52					1	1					326 118 690	U.K.	Abdeckhaube kpl., schwarz		Hood cpl., black	Capot protection cpl., noir	Tapa protectora cpl., negro
2	53	1	1	1	1			1	1	1	1	394 118 050		Verschluß-Unterteil		Bayonet lock	Clip de baïonnette	Alojamiento de la bayoneta
2	54	4	4	4	4	4	4	4	4	4	4	908 605 505		Innenstern-Schraube	M5x50	Screw	Vis	Tornillo
2	55	1				1						980 114 963		Schild	PC-6412 S	Label	Plaque	Calcomania
2	55	1										980 114 964		Schild	PC-6414 S	Label	Plaque	Calcomania
2	55		1									980 114 965		Schild	PC-7312 S	Label	Plaque	Calcomania
2	55			1		1						980 114 966		Schild	PC-7314 S	Label	Plaque	Calcomania
2	55							1				980 115 156	U.S.A.	Schild	PC-6430	Label	Plaque	Calcomania
2	55								1			980 115 157	U.S.A.	Schild	PC-6435	Label	Plaque	Calcomania
2	55									1		980 115 158	U.S.A.	Schild	PC-7330	Label	Plaque	Calcomania
2	55										1	980 115 159	U.S.A.	Schild	PC-7335	Label	Plaque	Calcomania
2	56	1	1	1	1	1	1	1	1	1	1	980 114 999		Schild	MIX	Label	Plaque	Calcomania

PC-6412 S PC-6430
PC-6414 S PC-6435
PC-7312 S PC-7330
PC-7314 S PC-7335

3

Schalldämpfer
Muffler
Pot d' échappement
Silencioso

DOLMAR

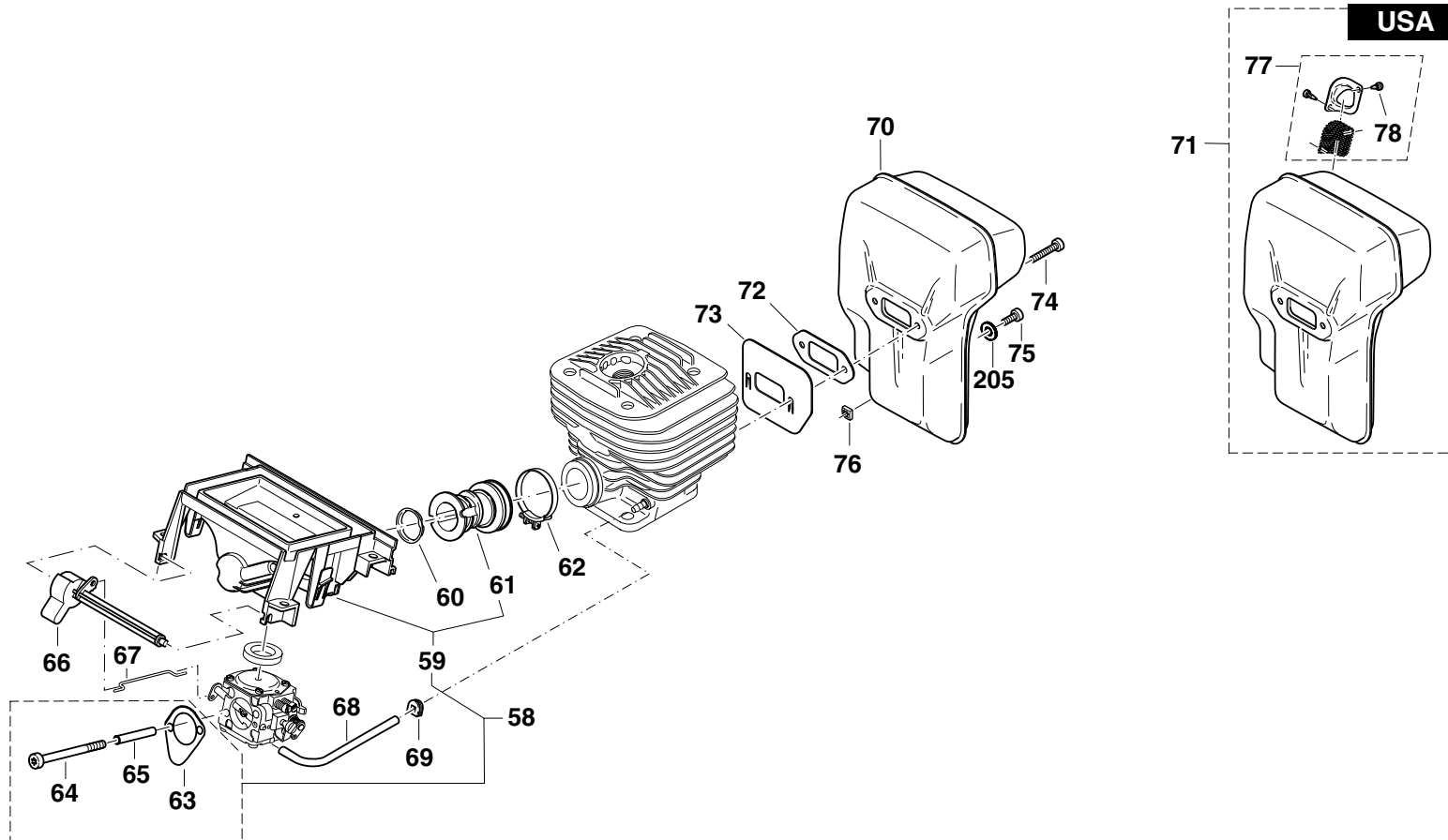

PC-6412 S, 6414 S, 7312 S, 7314 S
PC-6430, 6435, 7330, 7335



Seite / Page	Pos.	PC-6412 S int.	PC-6414 S int.	PC-7312 S int.	PC-7314 S int.	PC-6412 S U.K.	PC-7314 S U.K.	PC-6430 U.S.A.	PC-6435 U.S.A.	PC-7330 U.S.A.	PC-7335 U.S.A.	Teil-Nr. Part No. No. de pièce No. de pieza	Hinweise Notes Renseign. Nota	Bezeichnung	Spezifikation Specification	Description	Désignation	Denominación
3	58	1	1	1	1	1	1	1	1	1	1	957 171 394		Umbausatz Ansaugkrümmer		Modification set connecting sleeve	Jeu de modification manchon de jonction	Juego de reconstrucción manguito de conexión
3	59	1	1	1	1	1	1	1	1	1	1	394 171 051		Ansaugkrümmer kpl.		Connecting sleeve cpl.	Manchon de jonction cpl.	Manguito de conexión cpl.
3	60	1	1	1	1	1	1	1	1	1	1	024 131 031		Einsatz für Ansaugschlauch		Insert for suction hose	Pièce p. tuyau d'aspiration	Suplemento p. tubo d. asp.
3	61	1	1	1	1	1	1	1	1	1	1	394 131 101		Ansaugschlauch		Suction line	Conduite d'aspiration	Conducto de aspiración
3	62	1	1	1	1	1	1	1	1	1	1	965 603 050		Schlauchschelle		Hose clip	Collier de serrage	Abrazadera
3	63	1	1	1	1	1	1	1	1	1	1	965 518 120		Dichtung		Gasket	Joint	Junta
3	64	2	2	2	2	2	2	2	2	2	2	908 204 555		Innenstern-Schraube	M4x55	Screw	Vis	Tornillo
3	65	m	m	m	m	m	m	m	m	m	m	970 502 050		Schlauch	37mm; 1 1/2"	Tube	Gaine	Tubo
3	66	1	1	1	1	1	1	1	1	1	1	394 150 030		Chokewelle		Choke shaft	Axe pour clapet d' air	Eje para válvula de aire
3	67	1	1	1	1	1	1	1	1	1	1	394 150 042		Chokestange		Choke shaft	Levier pour clapet d' air	Palance de válvula de aire
3	68	m	m	m	m	m	m	m	m	m	m	965 452 380		Impulsschlauch	116mm; 4 1/2"	Tube	Gaine	Tubo
3	69	1	1	1	1	1	1	1	1	1	1	965 401 016		Gummitülle		Rubber bush	Gaine caoutchouc	Boquilla de caucho
3	70	1	1	1	1	1	1					394 174 011		Schalldämpfer		Muffler	Pot d' échappement	Silencioso
3	71							1	1	1	1	394 174 151	U.S.A.	Schalldämpfer	USA	Muffler	Pot d' échappement	Silencioso
3	72	1	1	1	1	1	1	1	1	1	1	965 531 130		Dichtung		Gasket	Joint	Junta
3	73	1	1	1	1	1	1	1	1	1	1	394 174 050		Abschirmblech		Cover plate	Tôle de protection	Chapa deflectora
3	74	2	2	2	2	2	2	2	2	2	2	908 405 205		Innenstern-Schraube	M5x20	Screw	Vis	Tornillo
3	75	1	1	1	1	1	1	1	1	1	1	908 005 125		Innenstern-Schraube	M5x12	Screw	Vis	Tornillo
3	76	1	1	1	1	1	1	1	1	1	1	921 905 004		4kt-Mutter	M5	Square nut	Ecrou carré	Tuerca cuadr.
3	77							1	1	1	1	394 174 141	U.S.A.	Funkenschutzsieb		Spark arrestor screen	Tamis	Tamiz
3	78							2	2	2	2	915 035 140	U.S.A.	Schraube		Screw	Vis	Tornillo
3	205	1	1	1	1	1	1	1	1	1	1	928 405 000		Spannscheibe		Disc	Disque	Arandela

**PC-6412 S, 6414 S, 7312 S, 7314 S
PC-6430, 6435, 7330, 7335**



Seite / Page	Pos.	PC-6412 S int.	PC-6414 S int.	PC-7312 S int.	PC-7314 S int.	PC-6412 S U.K.	PC-7314 S U.K.	PC-6430 U.S.A.	PC-6435 U.S.A.	PC-7330 U.S.A.	PC-7335 U.S.A.	Teil-Nr. Part No. No. de pièce No. de pieza	Hinweise Notes Renseign. Nota	Bezeichnung	Spezifikation Specification	Description	Désignation	Denominación
4	79	1	1	1	1	1	1	1	1	1	1	394 150 050		Vergaser mit Dichtung	HS-273 A	Carburetor with gasket	Carburateur avec joint	Carburador con junta
4	80	1	1	1	1	1	1	1	1	1	1	965 402 970		Dichtung		Gasket	Joint	Junta
4	81	1	1	1	1	1	1	1	1	1	1	394 150 160		Pumpendeckel kpl.		Pump cover cpl.	Couvercle de pompe cpl.	Tapa de bomba cpl.
4	82	4	4	4	4	4	4	4	4	4	4	394 150 170		Schraube		Screw	Vis	Tornillo
4	83	1	1	1	1	1	1	1	1	1	1	394 150 120		Membrandeckel		Diaphragm cover	Couvercle de membrane	Tapa de membrana
4	84	4	4	4	4	4	4	4	4	4	4	001 150 520		Schraube		Screw	Vis	Tornillo
4	85	1	1	1	1	1	1	1	1	1	1	957 150 100		Membransatz Till. HS Gummi		Set diaphragm / gaskets	Jeu de membranes / joints	Juego membranas / juntas
4	86	1	1	1	1	1	1	1	1	1	1	113 150 150		Pumpenmembrane, Gummi		Pump diaphragm, rubber	Membr. de pompe, caoutch.	Membr. d. la bomba, caucho
4	87	1	1	1	1	1	1	1	1	1	1	394 150 300		Drosselklappenwelle		Throttle shaft	Axe clapet d' étranglem.	Eje válvula regulador
4	88	1	1	1	1	1	1	1	1	1	1	394 150 310		Drehfeder		Spring	Ressort	Resorte
4	89	1	1	1	1	1	1	1	1	1	1	144 151 315		Buchse		Bushing	Douille	Casquillo
4	90	1	1	1	1	1	1	1	1	1	1	144 151 315		Buchse		Bushing	Douille	Casquillo
4	91	1	1	1	1	1	1	1	1	1	1	144 151 320		Drosselklappe		Throttle shutter	Clapet d' étranglement	Válvula reguladora
4	92	1	1	1	1	1	1	1	1	1	1	001 150 650		Schraube		Screw	Vis	Tornillo
4	93	1	1	1	1	1	1	1	1	1	1	001 150 650		Schraube		Screw	Vis	Tornillo
4	94	1	1	1	1	1	1	1	1	1	1	122 151 400		Scheibe		Disc	Disque	Disco
4	95	1	1	1	1	1	1	1	1	1	1	100 150 350		Sicherungsscheibe		Safety washer	Rondelle sécurité	Arandela seguridad
4	96	1	1	1	1	1	1	1	1	1	1	394 150 250		Chokewelle		Choke shaft	Axe pour clapet d' air	Eje para válvula de aire
4	97	1	1	1	1	1	1	1	1	1	1	113 150 261		Chokeklappe		Choke shutter	Clapet d' air	Válvula de aire
4	98	1	1	1	1	1	1	1	1	1	1	101 150 080		Arretierfeder		Locking spring	Ressort d' arrêt	Resorte de tope
4	99	1	1	1	1	1	1	1	1	1	1	113 150 380		Arretierkugel		Locking ball	Bille d' arrêt	Bola de tope
4	100	1	1	1	1	1	1	1	1	1	1	394 150 570		Leerlauf-Anschlagschraube	S	Idle stop screw	Vis de butée de ralenti	Tornillo de tope
4	101	1	1	1	1	1	1	1	1	1	1	394 150 470		Leerlauf-Stellschraube	L	Idle adjustment screw	Vis de régl. de ralenti	Tornillo regulador
4	102	1	1	1	1	1	1	1	1	1	1	394 150 510		Vollgas-Stellschraube	H	Main adjustm. screw	Vis de régl. plein gaz	Tornillo regulador
4	103	1	1	1	1	1	1	1	1	1	1	144 151 480		Feder		Spring	Ressort	Resorte
4	104	1	1	1	1	1	1	1	1	1	1	144 151 480		Feder		Spring	Ressort	Resorte
4	105	1	1	1	1	1	1	1	1	1	1	394 150 500		O-Ring		Packing ring	Bague-joint	Anillo de guarnición
4	106	1	1	1	1	1	1	1	1	1	1	394 150 500		O-Ring		Packing ring	Bague-joint	Anillo de guarnición
4	107	1	1	1	1	1	1	1	1	1	1	957 150 160		Satz Steuerteile		Set of control parts	Jeu de pièces de comm.	Juego piezas de mando
4	108	1	1	1	1	1	1	1	1	1	1	394 150 180		Sieb		Screen	Tamis	Tamiz
4	109	1	1	1	1	1	1	1	1	1	1	113 150 040		Verschlußscheibe		Cover disc	Disque de fermeture	Disco de sierre
4	110	1	1	1	1	1	1	1	1	1	1	001 150 510		Arretierkugel		Locking ball	Bille d' arrêt	Bola de tope

PC-6412 S PC-6430
PC-6414 S PC-6435
PC-7312 S PC-7330
PC-7314 S PC-7335

5

Anwerfvorrichtung, Magnetzündler
Starter, ignition
Dispositif de démarrage, volant magnétique
Dispositivo arranque, volante magnético

DOLMAR
■■■■■■■■■■

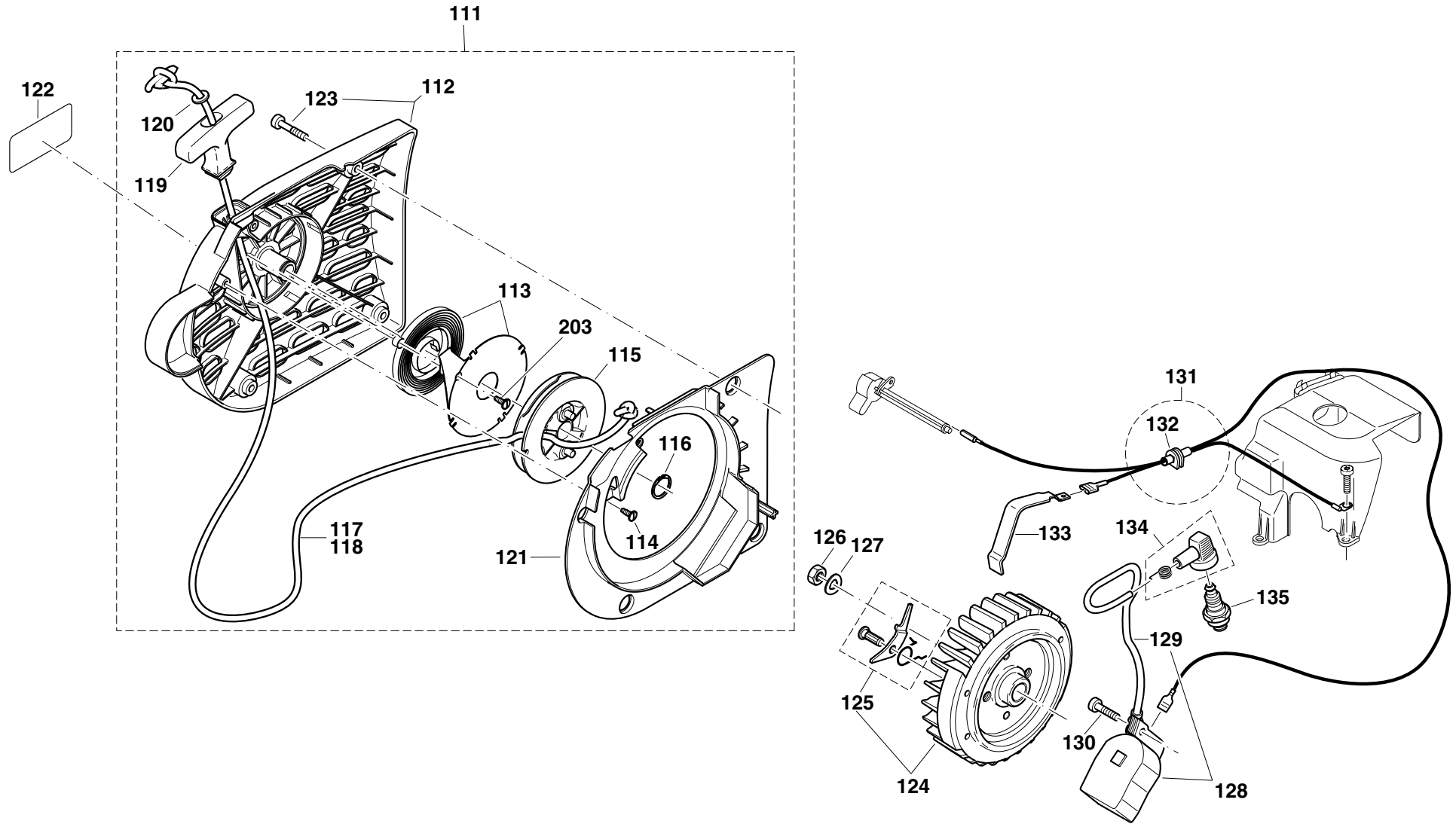

PC-6412 S, 6414 S, 7312 S, 7314 S
PC-6430, 6435, 7330, 7335



Seite / Page	Pos.	PC-6412 S int.	PC-6414 S int.	PC-7312 S int.	PC-7314 S int.	PC-6412 S U.K.	PC-7314 S U.K.	PC-6430 U.S.A.	PC-6435 U.S.A.	PC-7330 U.S.A.	PC-7335 U.S.A.	Teil-Nr. Part No. No. de pièce No. de pieza	Hinweise Notes Renseign. Nota	Bezeichnung	Spezifikation Specification	Description	Désignation	Denominación
5	111	1	1	1	1	1	1	1	1	1	1	394 112 171		Anwerfvorrichtung kpl., rot		Starter assy., red	Dispos. de démarrage cpl., rouge	Dispos. de arranque cpl., rojo
5	112	1	1	1	1	1	1	1	1	1	1	394 112 161		Startergehäuse, rot		Fan housing, red	Carter de ventilateur, rouge	Cárter de ventilador, rojo
5	113	1	1	1	1	1	1	1	1	1	1	394 163 020		Rückholfeder im Gehäuse		Rewind spring in housing	Ressort de rappel dans boît	Resorte retenc. en caja
5	114	2	2	2	2	2	2	2	2	2	2	915 135 100		Schneidschraube	3,5x9,5	Thread forming screw	Vis taraudeuse	Tornillo
5	115	1	1	1	1	1	1	1	1	1	1	394 162 010		Seiltrommel		Cable drum	Tambour de câble	Tambour para cordón
5	116	1	1	1	1	1	1	1	1	1	1	929 314 100		Sicherungsring		Snap ring	Circlip	Anillo seguridad
5	117	1	1	1	1	1	1	1	1	1	1	122 164 010		Anwerfseil	ø4 x 1000mm	Starter rope	Câble de démarrage	Cordón de arranque
5	117	1	1	1	1	1	1	1	1	1	1	394 164 020	Acc.	Anwerfseil schwarz	ø4 x 1000mm	Starter rope black	Câble de démarrage noir	Cordón de arranque negro
5	118	1	1	1	1	1	1	1	1	1	1	985 000 165		Anwerfseil	ø4 x 100m	Starter rope	Câble de démarrage	Cordón de arranque
5	119	1	1	1	1	1	1	1	1	1	1	001 161 020		Anwerfgriff		Starter grip	Poignée de lancement	Tirador de arranque
5	120	1	1	1	1	1	1	1	1	1	1	928 405 000		Spannscheibe		Disc	Disque	Arandela
5	121	1	1	1	1	1	1	1	1	1	1	394 112 141		Luftführung		Air guide plate	Guide d'air	Conducto de aire
5	122	1	1	1	1	1	1	1	1	1	1	980 114 208		Schild	DOLMAR	Label	Plaque	Calcomania
5	123	4	4	4	4	4	4	4	4	4	4	908 605 205		Innenstern-Schlitz-Schraube	M5x20	Screw	Vis	Tornillo
5	124	1	1	1	1	1	1	1	1	1	1	394 141 030		Polrad kpl.		Flywheel assy.	Roue polaire cpl.	Volante encendido
5	125	2	2	2	2	2	2	2	2	2	2	031 166 010		Anwerfklinke kpl.		Starter ratchet cpl.	Cliquet cpl.	Trinquete arranque cpl.
5	126	1	1	1	1	1	1	1	1	1	1	920 208 024		6kt-Mutter	M8x1	Hexagonal nut	Ecrou hexagonal	Tuerca hexagonal
5	127	1	1	1	1	1	1	1	1	1	1	926 208 001		Federscheibe	B8	Spring washer	Rondelle à ressort	Arandela elástica
5	128	1	1	1	1	1	1	1	1	1	1	394 143 013		Magnetzündler		Ignition coil	Bobine d' allumage	Bobina encendido
5	129	m	m	m	m	m	m	m	m	m	m	970 310 200		Zündleitung	360mm; 14 ¹ / ₈ "	Ignition cable	Câble d' allumage	Cable encendido
5	130	2	2	2	2	2	2	2	2	2	2	908 605 205		Innenstern-Schlitz-Schraube	M5x20	Screw	Vis	Tornillo
5	131	1	1	1	1	1	1	1	1	1	1	965 605 433		Kabel mit Stecker		Cable with plug	Câble avec prise	Cable con enchufe
5	132	1	1	1	1	1	1	1	1	1	1	965 401 016		Gummitülle		Rubber bush	Gaine caoutchouc	Boquilla de caucho
5	133	1	1	1	1	1	1	1	1	1	1	394 146 012		Kontaktfeder		Contact spring	Ressort de contact	Resorte de contacto
5	134	1	1	1	1	1	1	1	1	1	1	957 604 240		Zündkerzenstecker kpl.		Spark plug cap cpl.	Fiche de bougie, cpl.	Tapa de bujia cpl.
5	135	1	1	1	1	1	1	1	1	1	1	965 603 021		Zündkerze		Spark plug	Bougie	Bujia
5	203	1	1	1	1	1	1	1	1	1	1	915 135 100		Schneidschraube	3,5x9,5	Thread forming screw	Vis taraudeuse	Tornillo

PC-6412 S PC-6430
 PC-6414 S PC-6435
 PC-7312 S PC-7330
 PC-7314 S PC-7335

6

Zylinder, Kurbeltrieb, Kupplung
 Cylinder, crankshaft, clutch
 Cylindre, vilebrequin, embrayage
 Cilindro, cigüeñal, embrague

DOLMAR

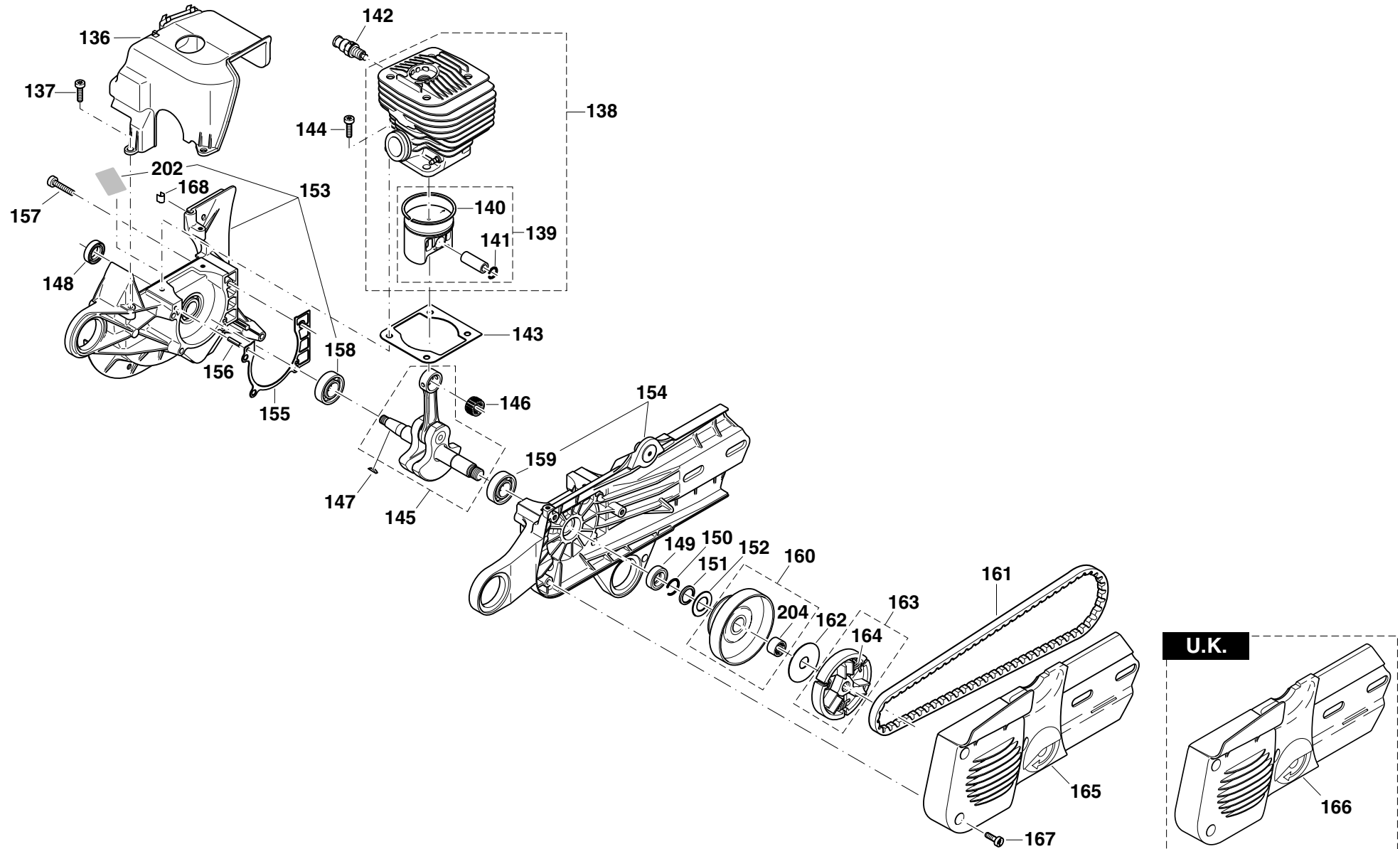

PC-6412 S, 6414 S, 7312 S, 7314 S
PC-6430, 6435, 7330, 7335



Seite / Page	Pos.	PC-6412 S int.	PC-6414 S int.	PC-7312 S int.	PC-7314 S int.	PC-6412 S U.K.	PC-7314 S U.K.	PC-6430 U.S.A.	PC-6435 U.S.A.	PC-7330 U.S.A.	PC-7335 U.S.A.	Teil-Nr. Part No. No. de pièce No. de pieza	Hinweise Notes Renseign. Nota	Bezeichnung	Spezifikation Specification	Description	Désignation	Denominación
6	136	1	1	1	1	1	1	1	1	1	1	394 131 041		Kühlfluthaube, schwarz		Hood, black	Capot, noir	Cubierta, negro
6	137	3	3	3	3	3	3	3	3	3	3	908 005 165		Innenstern-Schraube	M5x16	Screw	Vis	Tornillo
6	138	1	1			1		1	1			325 130 032		Zylinder / Kolben, kpl.	ø 47 Deco	Cylinder / piston, cpl.	Cylindre et piston, cpl.	Cilindro con pistón, cpl.
6	138			1	1	1				1	1	394 130 013		Zylinder / Kolben, kpl.	ø 50 Deco	Cylinder / piston, cpl.	Cylindre et piston, cpl.	Cilindro con pistón, cpl.
6	139	1	1			1		1	1			325 132 032		Kolben AB kpl.	ø 47	Piston cpl.	Piston cpl.	Pistón cpl.
6	139			1	1	1				1	1	394 132 111		Kolben AB kpl.	ø 50	Piston cpl.	Piston cpl.	Pistón cpl.
6	140	1	1			1		1	1			325 132 050		Kolbenring	ø 47	Piston ring	Segment de piston	Segmento de pistón
6	140			1	1	1				1	1	394 132 020		Kolbenring	ø 50	Piston ring	Segment de piston	Segmento de pistón
6	141	2	2	2	2	2	2	2	2	2	2	119 132 060		Sprengring		Spring ring	Anneau-ressort	Anillo elástico
6	142	1	1	1	1	1	1	1	1	1	1	001 131 150		Dekompressionsventil		Decompression valve	Soupape de décompres.	Válvula de decompresión
6	143	1	1	1	1	1	1	1	1	1	1	965 531 160		Zylinderfußdichtung		Gasket	Joint	Junta
6	144	4	4	4	4	4	4	4	4	4	4	908 005 205		Innenstern-Schraube	M5x20	Screw	Vis	Tornillo
6	145	1	1	1	1	1	1	1	1	1	1	394 120 010		Kurbelwelle kpl.		Crankshaft cpl.	Vilebrequin cpl.	Cigüeñal cpl.
6	146	1	1	1	1	1	1	1	1	1	1	962 210 015		Nadelkäfig		Needle cage	Cage à aiguilles	Jaula de agujas
6	147	1	1	1	1	1	1	1	1	1	1	939 630 370		Scheibenfeder		Key	Clavette	Chaveta
6	148	1	1	1	1	1	1	1	1	1	1	962 900 052		Radialdichtring	ø15/24x7	Radial ring	Joint radial	Junta radial
6	149	1	1	1	1	1	1	1	1	1	1	962 900 052		Radialdichtring	ø15/24x7	Radial ring	Joint radial	Junta radial
6	150	1	1	1	1	1	1	1	1	1	1	930 916 160		Sprengring		Spring ring	Anneau-ressort	Anillo elástico
6	151	1	1	1	1	1	1	1	1	1	1	394 245 010		Anschlagring, gehärtet, verzinkt		Stop ring, hardened	Bague de butée, durcie	Anillo de deten., endurecido
6	152	1	1	1	1	1	1	1	1	1	1	394 182 020		Führungsscheibe		Guide disc	Disque de guidage	Disco de guía
6	153	1	1	1	1	1	1	1	1	1	1	394 111 731		Kurbelgehäuse kpl. MS, schwarz		Crankc., mag. side, black	Carter-coté, magn., noir	Cárter cig., lado mag., negro
6	154	1	1	1	1	1	1	1	1	1	1	394 111 740		Kurbelgehäuse kpl. KS, schwarz		Crankc., clutch side, black	Carter-coté, embr., noir	Cárter cig., lado embr., negro
6	155	1	1	1	1	1	1	1	1	1	1	965 531 110		Kurbelgehäusedichtung		Gasket	Joint	Junta
6	156	2	2	2	2	2	2	2	2	2	2	936 430 160		Spiralspannstift		Spiral clamping pin	Goupille	Pasador
6	157	5	5	5	5	5	5	5	5	5	5	908 005 305		Innenstern-Schraube	M5x30	Screw	Vis	Tornillo
6	158	1	1	1	1	1	1	1	1	1	1	960 102 159		Kugellager (einkleben)		Ball bearing (use glue)	Roulement à billes (à coller)	Rodam. de bolas (a colar)
6	159	1	1	1	1	1	1	1	1	1	1	960 102 159		Kugellager (einkleben)		Ball bearing (use glue)	Roulement à billes (à coller)	Rodam. de bolas (a colar)
6	160	1	1	1	1	1	1	1	1	1	1	394 223 023		Kupplungstrommel kpl.		Clutch drum assy.	Tambour cpl.	Tambor cpl.
6	161	1	1	1	1	1	1	1	1	1	1	965 300 470		Keilriemen		V-belt	Courroie trapez	Correa estrecho
6	162	1	1	1	1	1	1	1	1	1	1	001 182 041		Führungsscheibe		Guide disc	Disque de guidage	Disco de guía
6	163	1	1	1	1	1	1	1	1	1	1	010 180 022		Kupplung kpl.		Clutch assy.	Embrayage cpl.	Embrague cpl.
6	164	3	3	3	3	3	3	3	3	3	3	024 184 021		Zugfeder		Spring	Ressort	Resorte
6	165	1	1	1	1	1	1	1	1	1	1	394 213 070		Abdeckung mit Schlitzen, rot		Cover, red	Couvercle, rouge	Cubierta, rojo
6	166					1						394 213 080	U.K.	Abdeckung ohne Schlitze, rot		Cover, red -do not use on 73ccm machines	Couvercle, rouge	Cubierta, rojo
6	167	3	3	3	3	3	3	3	3	3	3	908 605 145		Innenstern-Schlitz-Schraube	M5x14	Screw	Vis	Tornillo
6	168	1	1	1	1	1	1	1	1	1	1	965 402 870		Fixiergummi, Satz = 35 Stück		Rubber plate, set=35 pcs.	Plaque de caoutch., jeu=35 piè	Plancha de cau., jue.=35pzs.
6	202	1	1	1	1	1	1	1	1	1	1	980 600 130		Isolationsfolie		Insulating sheet	Feuille isolante	Hoja aislante
6	204	1	1	1	1	1	1	1	1	1	1	962 300 017		Nadelhülse		Needle bush	Roulement à aiguilles	Jaula de agujas

PC-6412 S PC-6430
PC-6414 S PC-6435
PC-7312 S PC-7330
PC-7314 S PC-7335

7

Schneidvorsatz, Schutzhaube
Cutting device, protection hood
Dispositif de coupe, capot de protection
Dispositivo tranzadora, cubierta protectora

DOLMAR

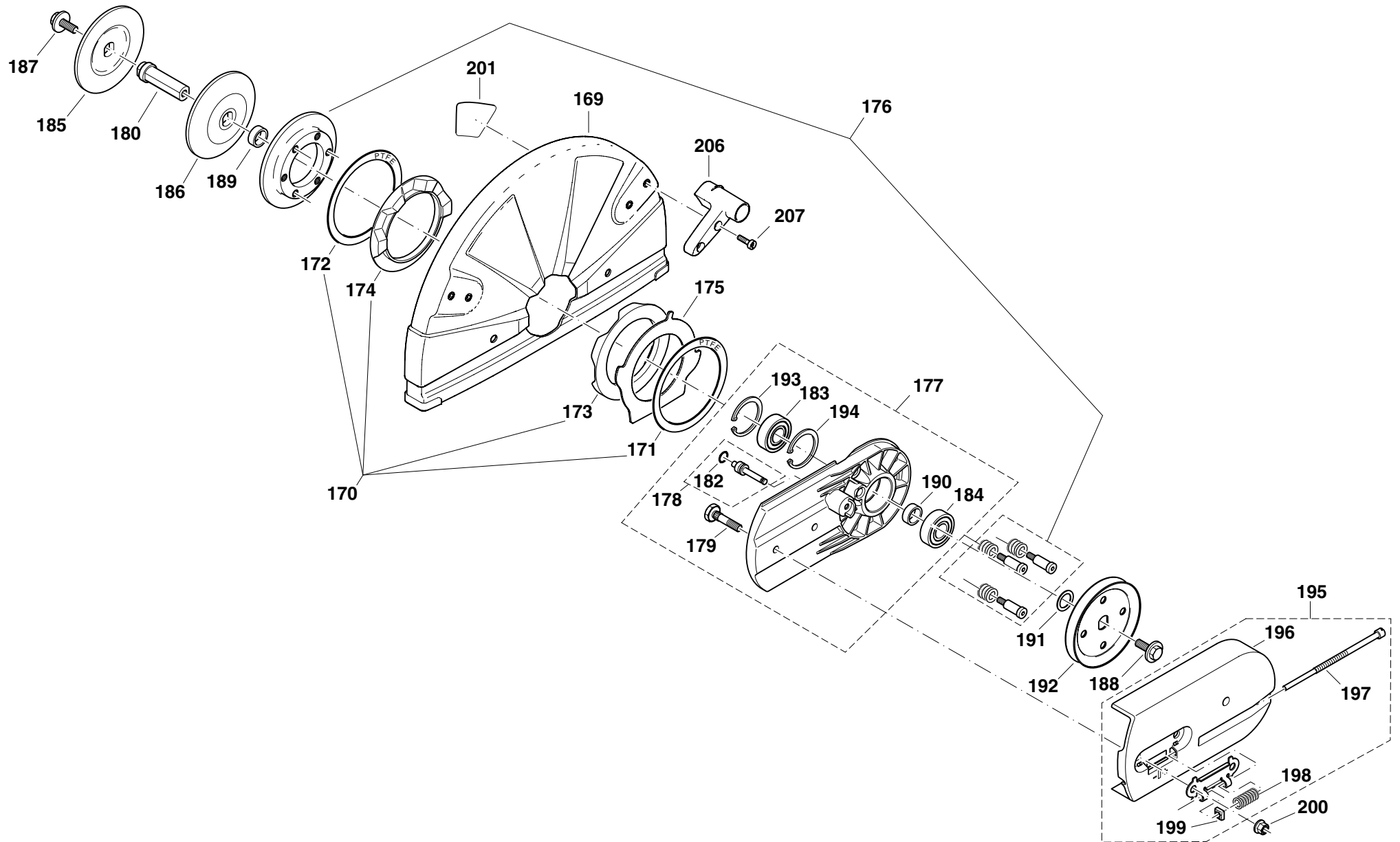

PC-6412 S, 6414 S, 7312 S, 7314 S
PC-6430, 6435, 7330, 7335



Seite / Page	Pos.	PC-6412 S int.	PC-6414 S int.	PC-7312 S int.	PC-7314 S int.	PC-6412 S U.K.	PC-7314 S U.K.	PC-6430 U.S.A.	PC-6435 U.S.A.	PC-7330 U.S.A.	PC-7335 U.S.A.	Teil-Nr. Part No. No. de pièce No. de pieza	Hinweise Notes Renseign. Nota	Bezeichnung	Spezifikation Specification	Description	Désignation	Denominación
7	169	1				1		1				325 341 611		Schutzhaube, silber	ø 300mm; 12"	Prot. hood, silver	Capot de protection, d'argent	Cubierta protec., plateado
7	169		1				1		1			394 341 011		Schutzhaube, silber	ø 350mm; 14"	Prot. hood, silver	Capot de protection, d'argent	Cubierta protec., plateado
7	170	1	1	1	1	1	1	1	1	1	1	957 342 011		Aufnahme Schutzhaube kpl.		Prot. hood mounting, cpl.	Logement capot de prot. cpl.	Alojamiento cub. prot., cpl.
7	171	1	1	1	1	1	1	1	1	1	1	394 342 180		Gleitscheibe Teflon		Sliding disc	Disque de glissement	Arandela deslizante
7	172	1	1	1	1	1	1	1	1	1	1	394 342 180		Gleitscheibe Teflon		Sliding disc	Disque de glissement	Arandela deslizante
7	173	1	1	1	1	1	1	1	1	1	1	965 404 900		Gummiring außen		Rubber ring ext.	Bague en caoutchouc ext.	Anillo de goma exterior
7	174	1	1	1	1	1	1	1	1	1	1	965 404 920		Gummiring innen		Rubber ring int.	Bague en caoutchouc int.	Anillo de goma interior
7	175	1	1	1	1	1	1	1	1	1	1	394 342 160		Anschlagblech		Impact plate	Tôle de butée	Chapa de tope
7	176	1	1	1	1	1	1	1	1	1	1	394 342 211		Druckring kpl., schwarz		Pressure ring cpl., black	Bague de pression cpl., noir	Anillo de presión cpl., negro
7	177	1	1	1	1	1	1	1	1	1	1	394 211 740		Schneidvorsatz kpl., schwarz		Cutting device assy., black	Dispositif de coupe cpl., noir	Dispos. tronzadora cpl., negro
7	178	1	1	1	1	1	1	1	1	1	1	394 342 190		Anschlagbolzen kpl.		Bolt cpl.	Boulon cpl.	Bulon cpl.
7	179	2	2	2	2	2	2	2	2	2	2	394 211 090		Bef.-Schraube gerändelt		Screw	Vis	Tornillo
7	180	1	1	1	1	1	1	1	1	1	1	394 228 100		Achse	ø 20mm	Axle	Axe	Eje
7	180		1				1				1	394 228 110		Achse	ø 25,4mm; 1"	Axle	Axe	Eje
7	180	1	1	1	1	1	1	1	1	1	1	394 228 130	Acc.	Achse	ø 22,2mm	Axle	Axe	Eje
7	182	1	1	1	1	1	1	1	1	1	1	963 209 020		O-Ring	9x2	Packing ring	Bague-joint	Anillo de guarnición
7	183	1	1	1	1	1	1	1	1	1	1	960 102 176		Kugellager		Ball bearing	Roulement à billes	Rodamiento de bolas
7	184	1	1	1	1	1	1	1	1	1	1	960 102 176		Kugellager		Ball bearing	Roulement à billes	Rodamiento de bolas
7	185	1	1	1	1	1	1	1	1	1	1	394 228 061		Spannflansch		Pressure disc	Disque de pression	Disco de presión
7	186	1	1	1	1	1	1	1	1	1	1	394 228 061		Spannflansch		Pressure disc	Disque de pression	Disco de presión
7	187	1	1	1	1	1	1	1	1	1	1	994 280 250		6kt-Schraube	M8x25	Hexagonal screw	Vis hexagonal	Tornillo hexagonal
7	188	1	1	1	1	1	1	1	1	1	1	994 280 250		6kt-Schraube	M8x25	Hexagonal screw	Vis hexagonal	Tornillo hexagonal
7	189	1	1	1	1	1	1	1	1	1	1	394 228 020		Distanzhülse		Spacer	Douille de distance	Casquillo separador
7	190	1	1	1	1	1	1	1	1	1	1	394 228 020		Distanzhülse		Spacer	Douille de distance	Casquillo separador
7	191	1	1	1	1	1	1	1	1	1	1	900 006 179		Paßscheibe		Disc	Disque	Arandela
7	192	1	1	1	1	1	1	1	1	1	1	394 221 010		Keilriemenscheibe		V-belt pulley	Poulie à gorge	Polea para correa
7	193	1	1	1	1	1	1	1	1	1	1	929 240 180		Sicherungsring		Snap ring	Circlip	Anillo seguridad
7	194	1	1	1	1	1	1	1	1	1	1	929 240 180		Sicherungsring		Snap ring	Circlip	Anillo seguridad
7	195	1	1	1	1	1	1	1	1	1	1	394 211 180		Abdeckung Schneidvors. kpl., rot		Cover cpl., red	Couvercle cpl., rouge	Cubierta cpl., rojo
7	196	1	1	1	1	1	1	1	1	1	1	394 211 025		Abdeckung Schneidvors., rot		Cover, red	Couvercle, rouge	Cubierta, rojo
7	197	1	1	1	1	1	1	1	1	1	1	394 213 031		Spannschraube		Tensioning screw	Vis de tension	Tornillo de tensión
7	198	1	1	1	1	1	1	1	1	1	1	394 342 120		Druckfeder		Spring	Ressort	Resorte
7	199	1	1	1	1	1	1	1	1	1	1	921 906 004		4kt-Mutter	M6	Square nut	Ecrou carré	Tuerca cuadr.
7	200	2	2	2	2	2	2	2	2	2	2	923 208 004		6kt-Mutter mit Bund	M8	Hexagonal nut	Ecrou hexagonal	Tuerca hexagonal
7	201	1					1					980 114 972		Sicherheitsaufkleber	ø300/20,0mm; ø12"/.787"	Safety label	Plaque	Calcomania
7	201		1				1					980 114 974		Sicherheitsaufkleber	ø350/20,0mm; ø14"/.787"	Safety label	Plaque	Calcomania
7	201		1				1					980 114 975		Sicherheitsaufkleber	ø350/25,4mm; ø14"/1"	Safety label	Plaque	Calcomania
7	206	1	1	1	1	1	1	1	1	1	1	326 341 300		Griff für Schutzhaube		Grip for protective hood	Poignée pour capot de protection	Asa para la capota de protección
7	207	2	2	2	2	2	2	2	2	2	2	908 605 165		Innenstern-Schlitz-Schraube	M5x16	Screw	Vis	Tornillo

PC-6412 S PC-6430
PC-6414 S PC-6435
PC-7312 S PC-7330
PC-7314 S PC-7335

8

Trennscheiben, Werkzeug
Blades, tools
Disques, outils
Discos para dividir, herramientas

DOLMAR

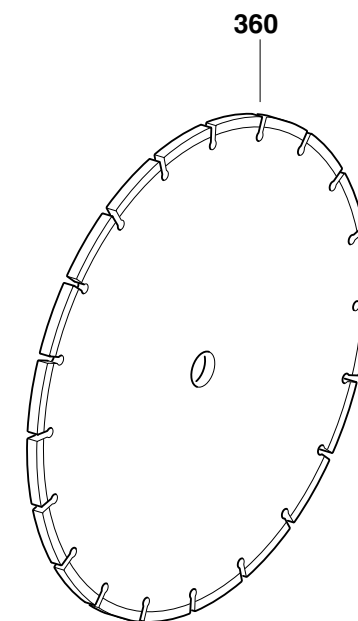
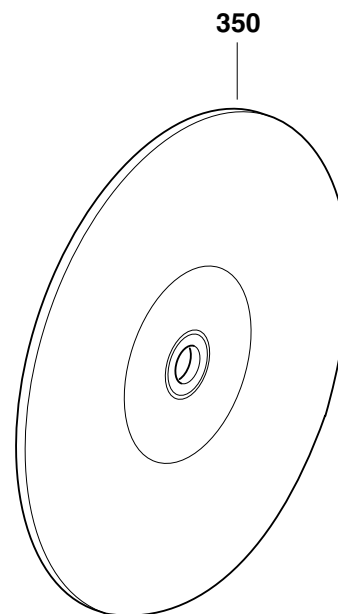
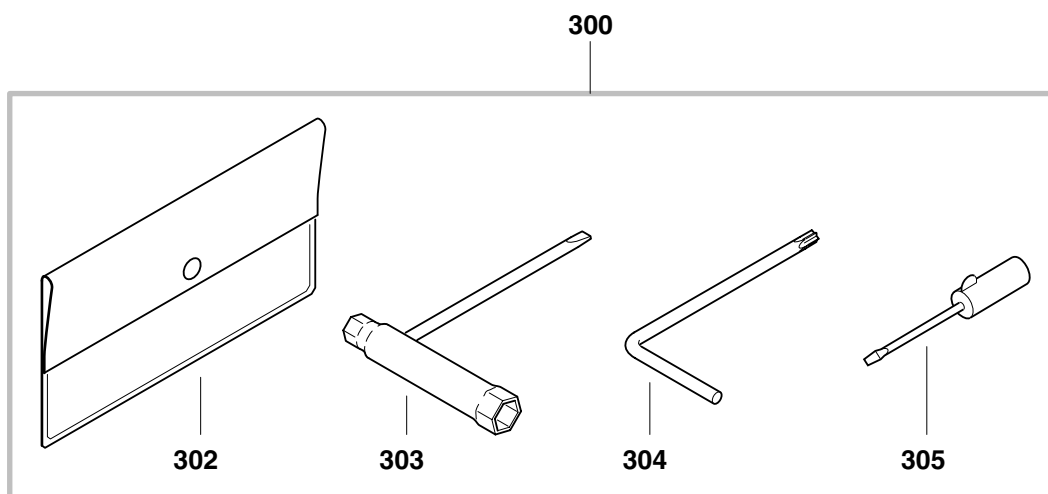

PC-6412 S, 6414 S, 7312 S, 7314 S
PC-6430, 6435, 7330, 7335



Seite / Page	Pos.	PC-6412 S int.	PC-6414 S int.	PC-7312 S int.	PC-7314 S int.	PC-6412 S U.K.	PC-7314 S U.K.	PC-6430 U.S.A.	PC-6435 U.S.A.	PC-7330 U.S.A.	PC-7335 U.S.A.	Teil-Nr. Part No. No. de pièce No. de pieza	Hinweise Notes Renseign. Nota	Bezeichnung	Spezifikation Specification	Description	Désignation	Denominación
8	300	1	1	1	1	1	1	1	1	1	1	957 004 006		Werkzeug kpl.		Tools cpl.	Outils cpl.	Herramientas cpl.
8	302	1	1	1	1	1	1	1	1	1	1	950 004 002		Werkzeugtasche		Plastik bag	Pochette en plastique	Cartera herramientas
8	303	1	1	1	1	1	1	1	1	1	1	941 719 140		Kombischlüssel	SW 13/19	Universal wrench	Clé combinée	Llave de bujía
8	304	1	1	1	1	1	1	1	1	1	1	940 827 000		Winkelschraubendreher	T27	Angled screw driver	Clé angle	Llave angular
8	305	1	1	1	1	1	1	1	1	1	1	944 340 001		Schraubendreher		Screw driver	Tournevis	Destornillador
8	306	1	1	1	1	1	1	1	1	1	1	394 228 121	Acc.	Adapting	ø 20/25,4 mm	Adapter	Adaptateur	Adaptor
8	350	1	1	1	1	1	1	1	1	1	1	966 121 150		Trennsch. Harz, Stahl	300/20mm; 12"	Abras. blade, steel	Disque synth. Acier	Disco sint. Acero
8	350	1	1	1	1	1	1	1	1	1	1	966 141 150		Trennsch. Harz, Stahl	350/20mm; 14"	Abras. blade, steel	Disque synth. Acier	Disco sint. Acero
8	350	1	1	1	1	1	1	1	1	1	1	966 144 150		Trennsch. Harz, Stahl	350/25,4mm; 14"	Abras. blade, steel	Disque synth. Acier	Disco sint. Acero
8	350	1	1	1	1	1	1	1	1	1	1	966 121 120		Trennsch. Harz, Stein	300/20mm; 12"	Abras. blade, stone	Disque synth. Béton	Disco sint. Pedra
8	350	1	1	1	1	1	1	1	1	1	1	966 141 120		Trennsch. Harz, Stein	350/20mm; 14"	Abras. blade, stone	Disque synth. Béton	Disco sint. Pedra
8	350	1	1	1	1	1	1	1	1	1	1	966 144 120		Trennsch. Harz, Stein	350/25,4mm; 14"	Abras. blade, stone	Disque synth. Béton	Disco sint. Pedra
8	360	1	1	1	1	1	1	1	1	1	1	966 221 020	Acc.	Diamant, Beton Standard	300/20mm; 12"	Diamond blade Concrete Standard	Disque diamant, Béton Stand.	Disco diaman., Hormigón Stand.
8	360	1	1	1	1	1	1	1	1	1	1	966 244 020	Acc.	Diamant, Beton Standard	350/25,4mm; 14"	Diamond blade Concrete Standard	Disque diamant, Béton Stand.	Disco diaman., Hormigón Stand.
8	360	1	1	1	1	1	1	1	1	1	1	966 241 020	Acc.	Diamant, Beton Standard	350/20mm; 14"	Diamond blade Concrete Standard	Disque diamant, Béton Stand.	Disco diaman., Hormigón Stand.
8	360	1	1	1	1	1	1	1	1	1	1	966 321 020	Acc.	Diamant, Beton DiaDuran	300/20mm; 12"	Diamond blade Concrete DiaDuran	Disque diamant, Béton DiaDuran	Disco diaman., Hormigón DiaDuran
8	360	1	1	1	1	1	1	1	1	1	1	966 344 020	Acc.	Diamant, Beton DiaDuran	350/25,4mm; 14"	Diamond blade Concrete DiaDuran	Disque diamant, Béton DiaDuran	Disco diaman., Hormigón DiaDuran
8	360	1	1	1	1	1	1	1	1	1	1	966 341 020	Acc.	Diamant, Beton DiaDuran	350/20mm; 14"	Diamond blade Concrete DiaDuran	Disque diamant, Béton DiaDuran	Disco diaman., Hormigón DiaDuran
8	360	1	1	1	1	1	1	1	1	1	1	966 221 010	Acc.	Diamant, Asphalt Standard	300/20mm; 12"	Diamond blade Asphalt Stand.	Disque diamant, Asphalte Stand.	Disco diaman., Asfalto Stand.
8	360	1	1	1	1	1	1	1	1	1	1	966 244 010	Acc.	Diamant, Asphalt Standard	350/25,4mm; 14"	Diamond blade Asphalt Stand.	Disque diamant, Asphalte Stand.	Disco diaman., Asfalto Stand.
8	360	1	1	1	1	1	1	1	1	1	1	966 241 010	Acc.	Diamant, Asphalt Standard	350/20mm; 14"	Diamond blade Asphalt Stand.	Disque diamant, Asphalte Stand.	Disco diaman., Asfalto Stand.
8	360	1	1	1	1	1	1	1	1	1	1	966 321 010	Acc.	Diamant, Asphalt DiaDuran	300/20mm; 12"	Diamond blade Asphalt DiaDuran	Disque diamant, Asphalte DiaDuran	Disco diaman., Asfalto DiaDuran
8	360	1	1	1	1	1	1	1	1	1	1	966 344 010	Acc.	Diamant, Asphalt DiaDuran	350/25,4mm; 14"	Diamond blade Asphalt DiaDuran	Disque diamant, Asphalte DiaDuran	Disco diaman., Asfalto DiaDuran
8	360	1	1	1	1	1	1	1	1	1	1	966 341 010	Acc.	Diamant, Asphalt DiaDuran	350/20mm; 14"	Diamond blade Asphalt DiaDuran	Disque diamant, Asphalte DiaDuran	Disco diaman., Asfalto DiaDuran
8	360	1	1	1	1	1	1	1	1	1	1	966 544 060		Diamant, universal Rescue Force	350/25,4mm; 14"	Diamond, universal Rescue Force	Diamant, universal Rescue Force	Diamante, universal Rescue Force

**PC-6412 S, 6414 S, 7312 S, 7314 S
PC-6430, 6435, 7330, 7335**



Seite / Page	Pos.	PC-6412 S int.	PC-6414 S int.	PC-7312 S int.	PC-7314 S int.	PC-6412 S U.K.	PC-7314 S U.K.	PC-6430 U.S.A.	PC-6435 U.S.A.	PC-7330 U.S.A.	PC-7335 U.S.A.	Teil-Nr. Part No. No. de pièce No. de pieza	Hinweise Notes Renseign. Nota	Bezeichnung	Spezifikation Specification	Description	Désignation	Denominación
9	400	1	1	1	1	1	1					394 365 101		Druck-, Fallwasserarmatur		Water attachment kit	Jeu de raccordement d'eau	Acometida de agua
9	401	1	1	1	1	1	1					964 802 271		Schlauchkupplung	STOP	Coupling sleeve STOP	Manchon d'accouplement	Acoplamiento p. tubos
9	402	1	1	1	1	1	1	1	1	1	1	964 802 280		Einschraubnippel		Hose connector	Raccord pour tuyau	Boquilla roscada
9	403	1	1	1	1	1	1	1	1	1	1	964 802 290		Kugelventil		Shut off cock	Robinet d'arrêt	Llave de paso
9	404	1	1	1	1	1	1	1	1	1	1	394 365 160		Schelle		Clamp	Bride de fixation	Abrazadera
9	405	1	1	1	1	1	1	1	1	1	1	908 006 105		Innenstern-Schraube	M6x10	Screw	Vis	Tornillo
9	406	1	1	1	1	1	1	1	1	1	1	921 906 004		4kt-Mutter	M6	Square nut	Ecrou carré	Tuerca cuadr.
9	407	1	1	1	1	1	1	1	1	1	1	964 802 310		Schnellverschraubung		Connecting piece	Pièce de raccord	Pieza de unión
9	408	m	m	m	m	m	m	m	m	m	m	964 802 320		PU-Schlauch	405mm; 16"	Hose	Tuyau	Tubo
9	409	1	1	1	1	1	1	1	1	1	1	964 802 330		Schnellverschraubung T		Connecting piece T	Pièce de raccord	Pieza de unión
9	410	m	m		m		m	m				964 802 320		PU-Schlauch	180mm; 7"	Hose	Tuyau	Tubo
9	410		m	m		m		m		m		964 802 320		PU-Schlauch	210mm; 8 1/4"	Hose	Tuyau	Tubo
9	411	1	1	1	1	1	1	1	1	1	1	964 802 340		Schnellverschraubung L		Connecting piece L	Pièce de raccord	Pieza de unión
9	412	1	1	1	1	1	1	1	1	1	1	964 802 351		Hohlschraube (Düse)		Nozzle	Tuyère	Tobera
9	413	1	1	1	1	1	1	1	1	1	1	964 802 351		Hohlschraube (Düse)		Nozzle	Tuyère	Tobera
9	414	1	1	1	1	1	1	1	1	1	1	964 802 361		Hutmutter		Cap nut	Écrou borgne	Tuerca
9	415	1	1	1	1	1	1	1	1	1	1	964 802 361		Hutmutter		Cap nut	Écrou borgne	Tuerca
9	416							1	1	1	1	394 365 330	U.S.A.	Druck-, Fallwasserarmatur		Water attachment kit	Jeu de raccordement d'eau	Acometida de agua
9	417							1	1	1	1	964 802 400	U.S.A.	Schlauchkupplung	STOP 1 1/16"	Coupling sleeve STOP	Manchon d'accouplement	Acoplamiento p. tubos
9	420	1	1	1	1	1	1	1	1	1	1	957 802 200		Druckwassertank	10 l	Pressurised water tank	Réservoir d'eau sous pres.	Tanque de agua a pres.
9	421	1	1	1	1	1	1	1	1	1	1	394 365 180		Schlauchadapter		Connecting reducer	Raccord réducteur	Reductor
9	422	1	1	1	1	1	1	1	1	1	1	964 802 250		Schlauchschelle	ø10-16 mm	Hose clip	Collier de serrage	Abrazadera
9	423	1	1	1	1	1	1	1	1	1	1	964 802 250		Schlauchschelle	ø10-16 mm	Hose clip	Collier de serrage	Abrazadera
9	424	1	1	1	1	1	1	1	1	1	1	957 963 200		Dichtungssatz		Gasket set	Jeu de joints	Juego juntas

PC-6412 S PC-6430
PC-6414 S PC-6435
PC-7312 S PC-7330
PC-7314 S PC-7335

10

Führungswagen • Nicht im Lieferumfang
Guide trolley • Not included in delivery
Chariot de guidage • Non incl. dans la livraison
Carro de guía • No incluidos en entrega

DOLMAR



500

PT-2000WS
PT-2000
PT-1900
PT-1800

501

502

503

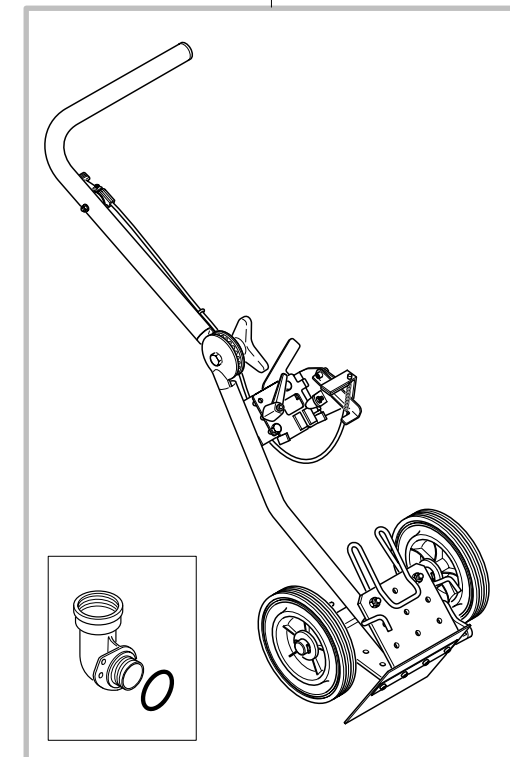
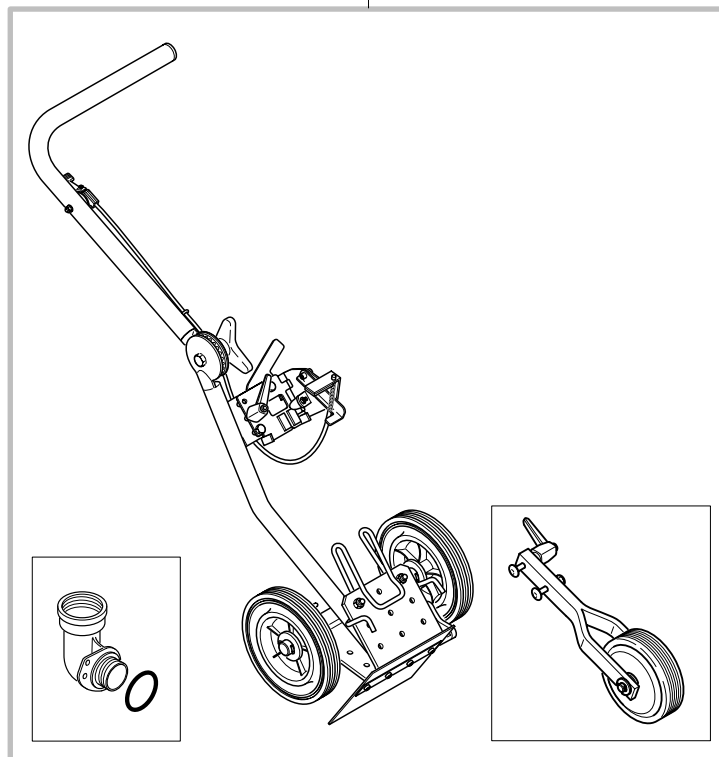
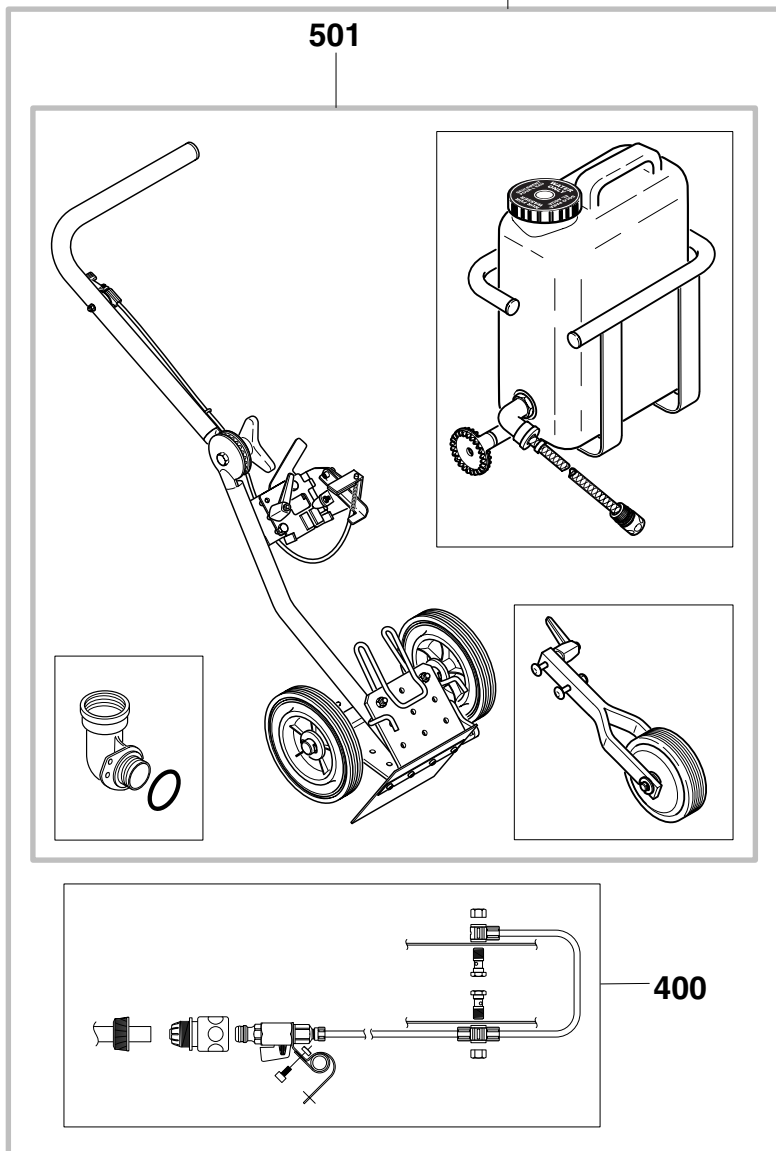

PC-6412 S, 6414 S, 7312 S, 7314 S
PC-6430, 6435, 7330, 7335



Seite / Page	Pos.	PC-6412 S int.	PC-6414 S int.	PC-7312 S int.	PC-7314 S int.	PC-6412 S U.K.	PC-7314 S U.K.	PC-6430 U.S.A.	PC-6435 U.S.A.	PC-7330 U.S.A.	PC-7335 U.S.A.	Teil-Nr. Part No. No. de pièce No. de pieza	Hinweise Notes Renseign. Nota	Bezeichnung	Spezifikation Specification	Description	Désignation	Denominación
10	500	1	1	1	1	1	1	1	1	1	1	700 394 323		Führungswagen	PT-2000 WS	Guide trolley cpl.	Chariot de guidage cpl.	Carro de guía cpl.
10	501	1	1	1	1	1	1	1	1	1	1	700 394 322		Führungswagen	PT-2000	Guide trolley cpl.	Chariot de guidage cpl.	Carro de guía cpl.
10	502	1	1	1	1	1	1	1	1	1	1	700 394 310		Führungswagen	PT-1900	Guide trolley	Chariot de guidage	Carro de guía
10	503	1	1	1	1	1	1	1	1	1	1	700 394 300		Führungswagen	PT-1800	Guide trolley	Chariot de guidage	Carro de guía

PC-6412 S PC-6430
 PC-6414 S PC-6435
 PC-7312 S PC-7330
 PC-7314 S PC-7335

11

Führungswagen • Nicht im Lieferumfang
Guide trolley • Not included in delivery
Chariot de guidage • Non incl. dans la livraison
Carro de guía • No incluidos en entrega



PT-2000WS
PT-2000
PT-1900
PT-1800

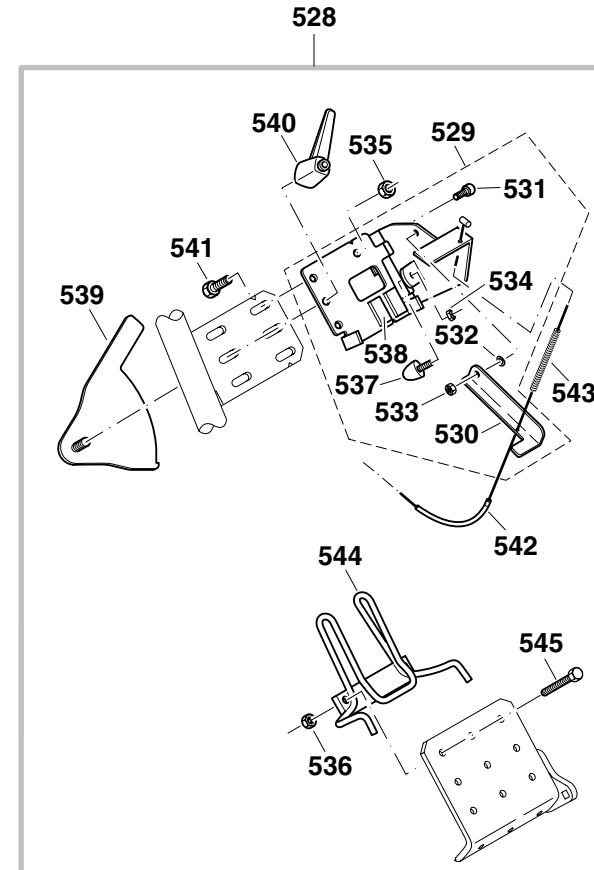
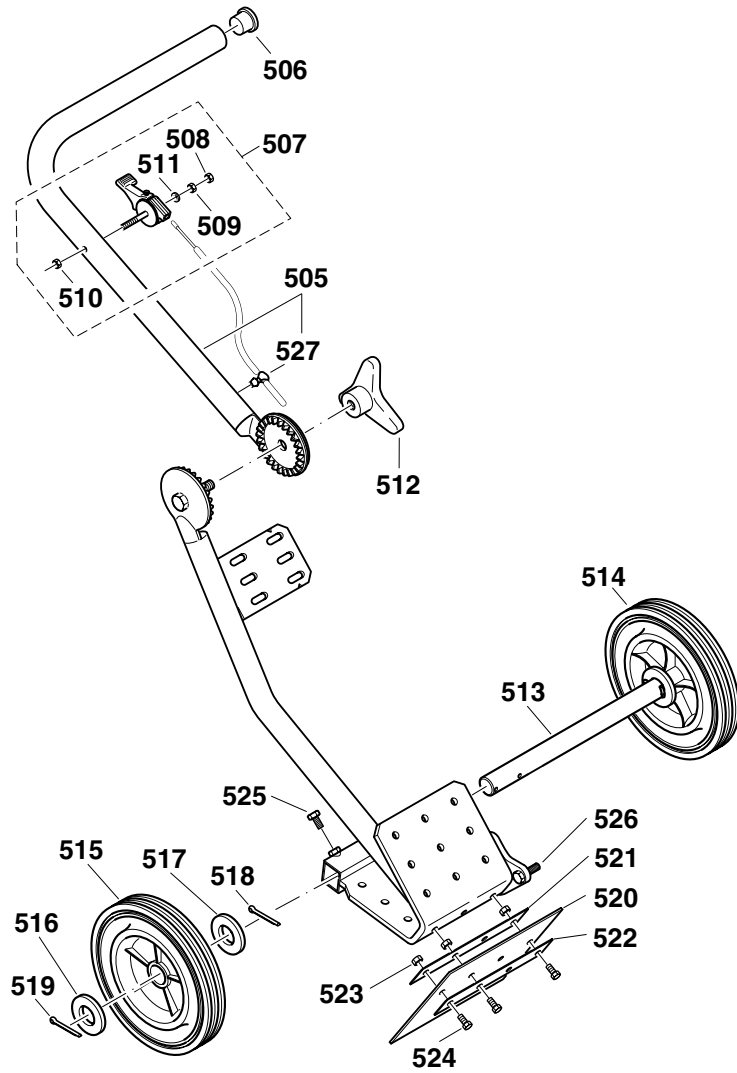

PC-6412 S, 6414 S, 7312 S, 7314 S
PC-6430, 6435, 7330, 7335



Seite / Page	Pos.	PC-6412 S int.	PC-6414 S int.	PC-7312 S int.	PC-7314 S int.	PC-6412 S U.K.	PC-7314 S U.K.	PC-6430 U.S.A.	PC-6435 U.S.A.	PC-7330 U.S.A.	PC-7335 U.S.A.	Teil-Nr. Part No. No. de pièce No. de pieza	Hinweise Notes Renseign. Nota	Bezeichnung	Spezifikation Specification	Description	Désignation	Denominación
11	505	1	1	1	1	1	1	1	1	1	1	394 361 280		Oberes Griffrohr, schwarz		Upper handle, black	Partie sup. mancheron, noir	Tube de guidage, negro
11	506	1	1	1	1	1	1	1	1	1	1	394 361 260		Rohrendstopfen		Plug	Bouchon	Tapón
11	507	1	1	1	1	1	1	1	1	1	1	398 312 060		Regulierhebel		Control lever	Levier de réglage	Palanca de ajuste
11	508	1	1	1	1	1	1	1	1	1	1	920 206 000		6kt-Mutter	M6	Hexagonal nut	Écrou hexagonal	Tuerca hexagonal
11	509	1	1	1	1	1	1	1	1	1	1	920 206 000		6kt-Mutter	M6	Hexagonal nut	Écrou hexagonal	Tuerca hexagonal
11	510	1	1	1	1	1	1	1	1	1	1	922 906 004		6kt-Mutter, selbstsichernd	M6	Hex. safety nut	Écrou hex. sécurité	Tuerca hex. seguridad
11	511	1	1	1	1	1	1	1	1	1	1	924 306 400		Scheibe	ø6,4	Disc	Disque	Arandela
11	512	1	1	1	1	1	1	1	1	1	1	985 000 580		Sterngriff	M12	Star knob	Manette	Manija de estrella
11	513	1	1	1	1	1	1	1	1	1	1	394 361 250		Achse	ø20	Axle	Axe	Eje
11	514	1	1	1	1	1	1	1	1	1	1	985 000 520		Rad	ø200	Wheel	Roue	Rueda
11	515	1	1	1	1	1	1	1	1	1	1	985 000 520		Rad	ø200	Wheel	Roue	Rueda
11	516	2	2	2	2	2	2	2	2	2	2	924 121 000		Scheibe	ø21	Washer	Rondelle	Arandela
11	517	2	2	2	2	2	2	2	2	2	2	924 121 000		Scheibe	ø21	Washer	Rondelle	Arandela
11	518	2	2	2	2	2	2	2	2	2	2	934 340 280		Splint		Cotter	Goupille fendue	Clavia
11	519	2	2	2	2	2	2	2	2	2	2	934 340 280		Splint		Cotter	Goupille fendue	Clavia
11	520	1	1	1	1	1	1	1	1	1	1	394 361 230		Gummilappen		Rubber flaps	Patte de caoutchouc	Solapa de caucho
11	521	1	1	1	1	1	1	1	1	1	1	394 361 240		Befestigungsblech		Fixing plate	Tôle de fixation	Chapa de fijación
11	522	1	1	1	1	1	1	1	1	1	1	394 361 240		Befestigungsblech		Fixing plate	Tôle de fixation	Chapa de fijación
11	523	3	3	3	3	3	3	3	3	3	3	922 908 004		6kt-Mutter, selbstsichernd	M8	Hex. safety nut	Écrou hex. sécurité	Tuerca hex. seguridad
11	524	3	3	3	3	3	3	3	3	3	3	900 208 254		6kt-Schraube	M8x25	Hexagonal screw	Vis hexagonal	Tornillo hexagonal
11	525	2	2	2	2	2	2	2	2	2	2	900 208 254		6kt-Schraube	M8x25	Hexagonal screw	Vis hexagonal	Tornillo hexagonal
11	526	1	1	1	1	1	1	1	1	1	1	394 211 090		Bef.-Schraube gerändelt		Screw	Vis	Tornillo
11	527	1	1	1	1	1	1	1	1	1	1	394 361 220		Kabelhalter		Cable holder	Support	Soporte
11	528	1	1	1	1	1	1	1	1	1	1	394 366 231		Adaptersatz, schwarz		Adapter, set, black	Adaptateur, jeu, noir	Adaptador, juego, negro
11	529	1	1	1	1	1	1	1	1	1	1	394 366 240		Aufnahmeblech hinten kpl., schw.		Mounting plate, rear, black	Tôle de réception arrière cpl., noir	Chapa de alojam. trasera, cpl., negro
11	530	1	1	1	1	1	1	1	1	1	1	394 366 280		Gasbetätigung, schwarz		Throttle control, black	Commande de gaz, noir	Mando del gas, negro
11	531	1	1	1	1	1	1	1	1	1	1	908 006 205		Innenstern-Schraube	M6x20	Screw	Vis	Tornillo
11	532	1	1	1	1	1	1	1	1	1	1	926 206 000		Federscheibe	B6	Spring washer	Rondelle ressort	Arandela presión
11	533	1	1	1	1	1	1	1	1	1	1	922 906 004		6kt-Mutter, selbstsichernd	M6	Hex. safety nut	Écrou hex. sécurité	Tuerca hex. seguridad
11	534	1	1	1	1	1	1	1	1	1	1	922 906 004		6kt-Mutter, selbstsichernd	M6	Hex. safety nut	Écrou hex. sécurité	Tuerca hex. seguridad
11	535	1	1	1	1	1	1	1	1	1	1	922 908 004		6kt-Mutter, selbstsichernd	M8	Hex. safety nut	Écrou hex. sécurité	Tuerca hex. seguridad
11	536	2	2	2	2	2	2	2	2	2	2	922 908 004		6kt-Mutter, selbstsichernd	M8	Hex. safety nut	Écrou hex. sécurité	Tuerca hex. seguridad
11	537	1	1	1	1	1	1	1	1	1	1	965 403 540		Parabelpuffer		Vibration damper	Armortisseur	Armortiguador
11	538	2	2	2	2	2	2	2	2	2	2	394 366 080		Moosgummiplatte		Rubber plate	Plaque de caoutchouc	Plancha de caucho
11	539	1	1	1	1	1	1	1	1	1	1	394 366 250		Exzenterspannblech, schwarz		Clamp plate, black	Plaque de serrage, noir	Chapa de sujeción, negro
11	540	1	1	1	1	1	1	1	1	1	1	394 366 070		Schnellspannhebel	M8x83	Quick clamp lever	Levier de serrage rapide	Palanca de sujeción rápida
11	541	1	1	1	1	1	1	1	1	1	1	900 208 204		6kt-Schraube	M8x20	Hexagonal screw	Vis hexagonal	Tornillo hexagonal
11	542	1	1	1	1	1	1	1	1	1	1	394 366 040		Bowdenzug		Bowden cable	Câble de commande	Transmis. flexible Bowden
11	543	1	1	1	1	1	1	1	1	1	1	394 366 060		Druckfeder		Spring	Ressort	Resorte
11	544	1	1	1	1	1	1	1	1	1	1	394 366 220		Spannbügel kpl.		Clamp assy.	Etrier de serrage cpl.	Abrazadera, cpl.
11	545	2	2	2	2	2	2	2	2	2	2	900 208 354		6kt-Schraube	M8x35	Hexagonal screw	Vis hexagonal	Tornillo hexagonal

PC-6412 S PC-6430
 PC-6414 S PC-6435
 PC-7312 S PC-7330
 PC-7314 S PC-7335

12

Führungswagen • Nicht im Lieferumfang
 Guide trolley • Not included in delivery
 Chariot de guidage • Non incl. dans la livraison
 Carro de guía • No incluidos en entrega



PT-2000WS
PT-2000
PT-1900
PT-1800

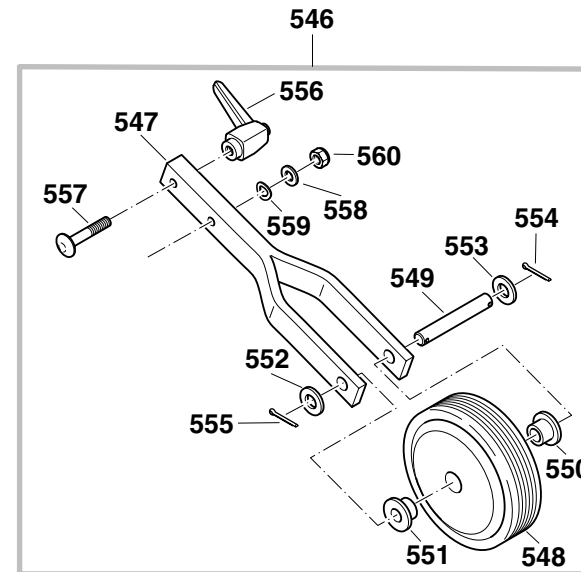
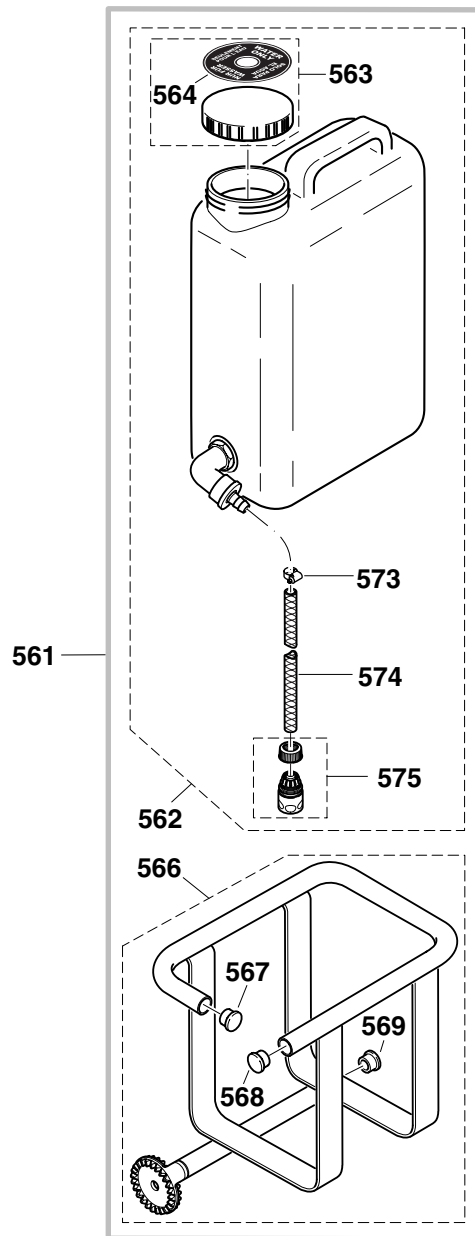

PC-6412 S, 6414 S, 7312 S, 7314 S
PC-6430, 6435, 7330, 7335



Seite / Page	Pos.	PC-6412 S int.	PC-6414 S int.	PC-7312 S int.	PC-7314 S int.	PC-6412 S U.K.	PC-7314 S U.K.	PC-6430 U.S.A.	PC-6435 U.S.A.	PC-7330 U.S.A.	PC-7335 U.S.A.	Teil-Nr. Part No. No. de pièce No. de pieza	Hinweise Notes Renseign. Nota	Bezeichnung	Spezifikation Specification	Description	Désignation	Denominación
12	546	1	1	1	1	1	1	1	1	1	1	394 362 021		Tiefenbegrenzer kpl., schwarz		Depth limiter assy., black	Limiteur de coupe cpl., noir	Limitador de profundidad cpl., negro
12	547	1	1	1	1	1	1	1	1	1	1	394 362 170		Radgabel, schwarz		Wheel fork, black	Fourche, noir	Horquilla de la rueda, negro
12	548	1	1	1	1	1	1	1	1	1	1	394 362 140		Stahlrad kpl.		Steel wheel assy.	Roue en acier cpl.	Rueda de acero, cpl.
12	549	1	1	1	1	1	1	1	1	1	1	394 362 160		Achse	ø14	Axle	Axe	Eje
12	550	1	1	1	1	1	1	1	1	1	1	394 362 150		Laufbuchse		Bush	Douille	Casquillo
12	551	1	1	1	1	1	1	1	1	1	1	394 362 150		Laufbuchse		Bush	Douille	Casquillo
12	552	1	1	1	1	1	1	1	1	1	1	924 115 000		Scheibe	ø15	Washer	Rondelle	Arandela
12	553	1	1	1	1	1	1	1	1	1	1	924 115 000		Scheibe	ø15	Washer	Rondelle	Arandela
12	554	1	1	1	1	1	1	1	1	1	1	934 332 220		Splint		Cotter	Goupille fendue	Clavía
12	555	1	1	1	1	1	1	1	1	1	1	934 332 220		Splint		Cotter	Goupille fendue	Clavía
12	556	1	1	1	1	1	1	1	1	1	1	394 366 070		Schnellspannhebel	M8x83	Quick clamp lever	Levier de serrage rapide	Palanca de sujeción rápida
12	557	1	1	1	1	1	1	1	1	1	1	909 608 404		Flachrundschraube	M8x40	Screw	Vis	Tornillo
12	558	1	1	1	1	1	1	1	1	1	1	925 108 400		Scheibe	ø8,4	Washer	Rondelle	Arandela
12	559	1	1	1	1	1	1	1	1	1	1	926 208 001		Federscheibe	B8	Spring washer	Rondelle ressort	Arandela presión
12	560	1	1	1	1	1	1	1	1	1	1	922 908 004		6kt-Mutter, selbstsichernd	M8	Hex. safety nut	Écrou hex. sécurité	Tuerca hex. seguridad
12	561	1	1	1	1	1	1	1	1	1	1	394 365 022		Tankset, schwarz		Water tank cpl., black	Réservoir d'eau cpl., noir	Tanque de agua cpl., negro
12	562	1	1	1	1	1	1	1	1	1	1	394 365 250		Wassertank kpl.	16 l	Water tank cpl.	Réservoir d'eau cpl.	Tanque de agua cpl.
12	563	1	1	1	1	1	1	1	1	1	1	394 365 295		Tankdeckel kpl.		Tank cover cpl.	Couvercle de réservoir cpl.	Tapa del tanque cpl.
12	564	1	1	1	1	1	1	1	1	1	1	980 114 921		Schild	WATER ONLY	Label	Plaque	Calcomania
12	566	1	1	1	1	1	1	1	1	1	1	394 365 310		Tankhalter, schwarz		Tank holder, black	Porte-réservoir, noir	Portador del depósito de agua, negro
12	567	1	1	1	1	1	1	1	1	1	1	394 365 320		Rohrendstopfen		Plug	Bouchon	Tapón
12	568	1	1	1	1	1	1	1	1	1	1	394 365 320		Rohrendstopfen		Plug	Bouchon	Tapón
12	569	1	1	1	1	1	1	1	1	1	1	394 365 200		Rohrendstopfen		Plug	Bouchon	Tapón
12	573	1	1	1	1	1	1	1	1	1	1	965 603 060		Schlauchschelle		Hose clip	Collier de serrage	Abrazadera
12	574	1	1	1	1	1	1	1	1	1	1	965 453 830		Schlauch	1/2", L=550mm	Hose	Tuyau	Tubo
12	575	1	1	1	1	1	1	1	1	1	1	964 802 271		Schlauchkupplung	STOP	Coupling sleeve	Manchon d'accouplement	Acoplamiento p. tubos

PC-6412 S PC-6430
 PC-6414 S PC-6435
 PC-7312 S PC-7330
 PC-7314 S PC-7335



	Zeichenerklärung (D)	Key to symbols (GB)	Légende (F)	Explicación de símbolos (E)
<p>⇒ 1999999 2000000 ⇒ 4/95 ⇒ SI 5/95 Acc. = { m Corr.</p>	<p>Produktion bis Serien-Nr. Neues Teil ab Serien-Nr. Neues Teil ab Monat / Jahr Siehe Technische Information Jahr / Nr. Zubehör (nicht im Lieferumfang) Keine Serienausführung, jedoch verwendbar Beinhaltet Positions-Nr. Meterware Druckfehlerberichtigung</p>	<p>Production to serial number New part from serial number New part from Month / Year See Technical Information Year / No. Accessories (not included in the delivery inventory) No standard execution, may be used Contains item number Sold by the meter Error correction</p>	<p>Production jusqu'à n° de série Nouveau pièce à partir du n° de série Nouveau pièce à partir de mois / année Voir information technique année / n° Accessoires (non compris dans la livraison) Aucune exécut. en série, cependant utilisable contient n° de numéro Au mètre Rectification d'erreurs</p>	<p>Producción hasta N° de serie Pieza nueva a partir de N° de serie Pieza nueva a partir de mes / año Véase inform. técnico año / N° Accesorios (no incluido en la extensión del suministro) No es de serie, pero sirve Contiene pos N° Por metro Fe de erratas</p>
	Verklaring der tekens (NL)	Chiarificazione dei simboli (I)	Objasnitev znakov (SLO)	Επεξήγηση συμβόλων (GR)
<p>⇒ 1999999 2000000 ⇒ 4/95 ⇒ SI 5/95 Acc. = { m Corr.</p>	<p>In productie tot serie-Nr. Nieuw onderdeel vanaf serie-Nr. Nieuw onderdeel vanaf maand / jaar Zie technische informatie jaar / Nr. Accessoires (niet meegeleverd) Geen serieuitvoering, maar wel bruikbaar Omvat Positie-Nr. Metergoed Drukfoutcorrectie</p>	<p>Produzione fino al n. di serie Nuovo pezzo a partire dal n. di serie Nuovo pezzo a partire dal mese / anno Vedere il inform. tecnici del anno / n. Accessori (non compresi nell'insieme di fornitura) Non è un modello di serie, ma ugualm. utilizza. Comprende la posizione n. Articoli a metraggio Rettifica di errori di stampa</p>	<p>Produkcija do serijske številke Novi del od serijske številke dalje Novi del od meseca / leta dalje Glej tehnične informacije od leta / številke. Pritikline (niso v obsegu dostave) Ni serijska izvedba, a uporabno Vsebuje pozicijsko število. Metersko blago Popravek tiskovnih napak</p>	<p>Παραγωγή μέχρι τον αριθμό σειράς Νέο εξάρτημα από τον αριθμό σειράς Νέο εξάρτημα από το μήνα / έτος Βλέπε πληροφορίες του τεχνικά το έτος / αριθμό Πρόσθετα εξαρτήματα (δεν ανήκουν στη συσκευασία παράδοσης) Δεν έχει εκδοθεί σε σειρά, αλλά χρησιμοποιείται Περιλαμβάνει τον αριθμό θέσης Εμπόρευμα με το μέτρο Διόρθωση λάθους πίεσης</p>

Änderungen vorbehalten
 Specifications subject to change without notice
 Changements sans préavis
 Mejoras constructivas sin previo aviso