

**Spare Parts List**  
**Ersatzteilliste**  
**Liste de pièces détachées**  
**Lista de piezas de repuesto**

2008-02

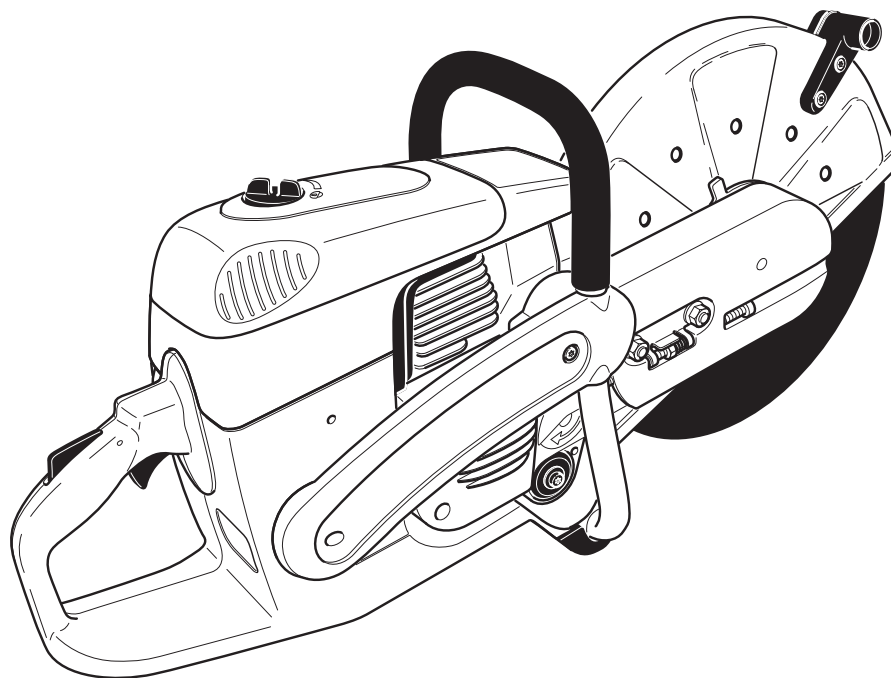

**PC-6412 S**  
**PC-6414 S**  
**PC-7312 S**  
**PC-7314 S**  
**PC-8114**  
**PC-8116**  
**PC-6412 S (UK)**  
**PC-7314 S (UK)**  
**PC-8114 (UK)**  
**PC-8116 (UK)**  
**PC-6430 (USA)**  
**PC-6435 (USA)**  
**PC-7330 (USA)**  
**PC-7330 C (USA)**  
**PC-7335 (USA)**  
**PC-7335 C (USA)**  
**PC-8135 (USA)**  
**PC-8140 (USA)**

**DOLMAR**



A member of the *Makita* Group

995 700 081 (D, GB, F, E)

PC-6412 S, PC-6414 S, PC-7312 S, PC-7314 S,  
 PC-8114, PC-8116, PC-6412 S (UK), PC-7314 S (UK),  
 PC-8114 (UK), PC-8116 (UK), PC-6430 (USA), PC-6435  
 (USA), PC-7330 (USA), PC-7330 C (USA), PC-7335 (USA),  
 PC-7335 C (USA), PC-8135 (USA), PC-8140 (USA)

**1**

Tankeinheit und Handgriffe  
 Tank and handle grips  
 Réservoir et poignées  
 Depósito y mangos

**DOLMAR**  
 A member of the *Makita* Group

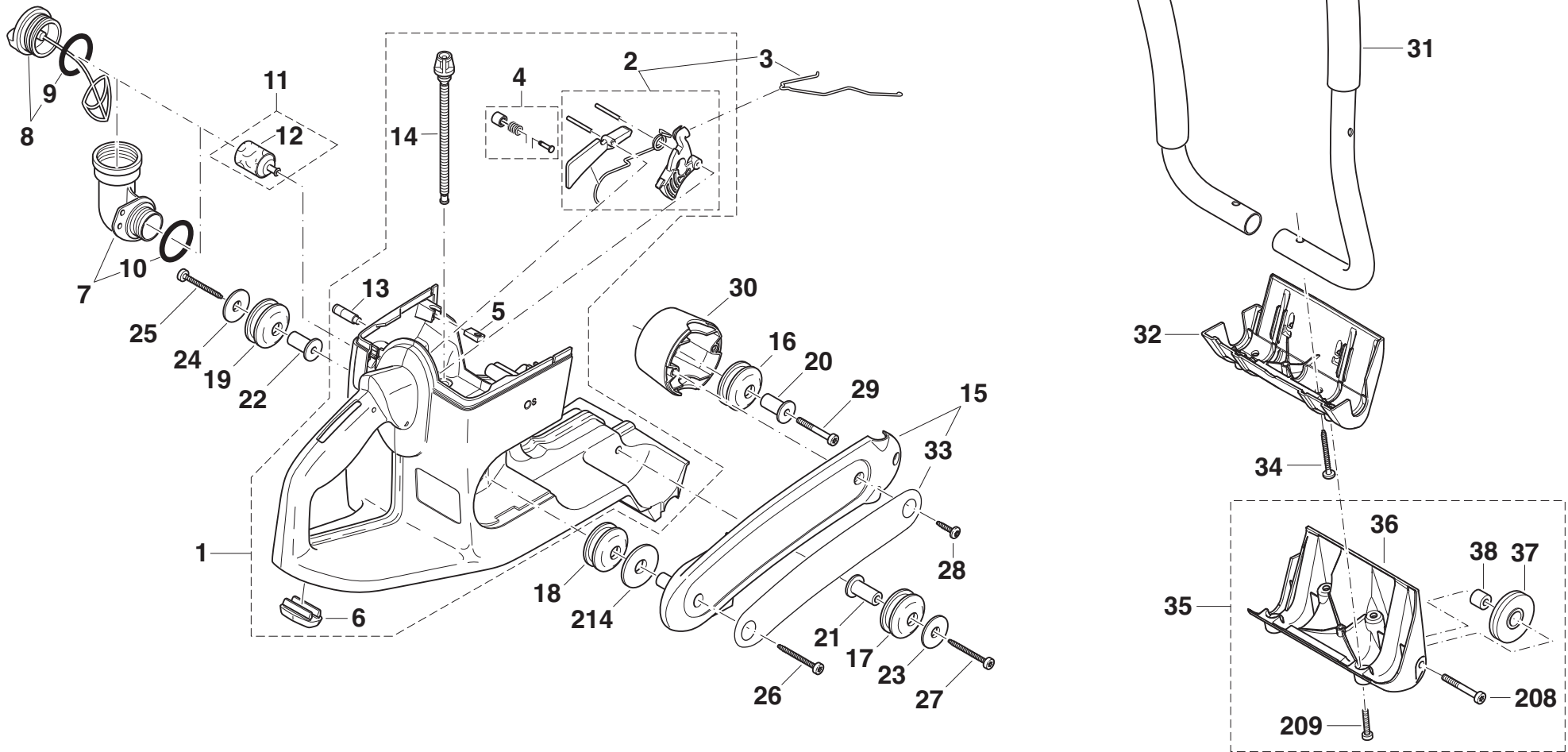

PC-6412 S, PC-6414 S, PC-7312 S, PC-7314 S,  
 PC-8114, PC-8116, PC-6412 S (UK), PC-7314 S (UK),  
 PC-8114 (UK), PC-8116 (UK), PC-6430 (USA), PC-6435  
 (USA), PC-7330 (USA), PC-7330 C (USA), PC-7335  
 (USA), PC-7335 C (USA), PC-8135 (USA), PC-8140 (USA)

1

Tankeinheit und Handgriffe  
 Tank and handle grips  
 Réservoir et poignées  
 Depósito y mangos

**DOLMAR**  
 A member of the **makita** Group

Seite / Page	Pos.	PC-6412 S	PC-6414 S	PC-7312 S	PC-7314 S	PC-8114	PC-8116	PC-6412 S (UK)	PC-7314 S (UK)	PC-8114 (UK)	PC-8116 (UK)	PC-6430 (USA)	PC-6435 (USA)	PC-7330 (USA)	PC-7330 C (USA)	PC-7335 (USA)	PC-7335 C (USA)	PC-8135 (USA)	PC-8140 (USA)	Teil-Nr. Part No. No. de pièce No. de pieza	Hinweise Notes Renseign. Nota	Bezeichnung	Spezifikation Specification	Description	Désignation	Denominación
1	1	1	1	1	1	1	1	1	1	1	1	1	1	1	1	1	1	1	1	394 114 007		Tank kpl. mit Mechanik, rot		Tank cpl., red	Réservoir cpl., rouge	Depósito cpl.
1	2	1	1	1	1	1	1	1	1	1	1	1	1	1	1	1	1	1	1	957 117 020		Gasmechanik kpl.		Throttle mechanism, cpl.	Mécanique de déclen. cpl.	Mecanismo acelerador, cpl.
1	3	1	1	1	1	1	1	1	1	1	1	1	1	1	1	1	1	1	1	394 117 011		Gasgestänge		Throttle linkage	Tringle d' accélération	Varilla acelerador
1	4	1	1	1	1	1	1	1	1	1	1	1	1	1	1	1	1	1	1	957 117 030		Halbgasarretierung kpl.		Half-throttle lock, cpl.	Dispos. d'arrêt demi-gaz cpl.	Bloqueo medio gas, cpl.
1	5	4	4	4	4	4	4	4	4	4	4	4	4	4	4	4	4	4	4	394 114 100		Schraubeinsatz		Screw plug	Embout de vissage	Alojamiento de tornillos
1	6	1	1	1	1	1	1	1	1	1	1	1	1	1	1	1	1	1	1	394 114 070		Gummifuß		Rubber foot	Pied, caotchouc	Pie, goma
1	7	1	1	1	1	1	1	1	1	1	1	1	1	1	1	1	1	1	1	010 114 081	Acc.	Winkeltankverschluß kpl.		Angular union assy.	Manchon coudé cpl.	Cierre angular cpl.
1	8	1	1	1	1	1	1	1	1	1	1	1	1	1	1	1	1	1	1	010 114 091		Tankdeckel kpl., Kraftstoff		Tank cap cpl.	Bouchon réservoir cpl.	Cierre depósito cpl.
1	9	1	1	1	1	1	1	1	1	1	1	1	1	1	1	1	1	1	1	963 230 031		O-Ring, rot	ø30x3	O-Ring, red	Bague joint, rouge	Anillo de guarnición, rojo
1	10	1	1	1	1	1	1	1	1	1	1	1	1	1	1	1	1	1	1	963 230 031	Acc.	O-Ring, rot	ø30x3	O-Ring, red	Bague joint, rouge	Anillo de guarnición, rojo
1	11	1	1	1	1	1	1	1	1	1	1	1	1	1	1	1	1	1	1	963 601 120		Saugkopf kpl.		Suction head	Tête d' aspiration	Cabeza de aspiración
1	12	1	1	1	1	1	1	1	1	1	1	1	1	1	1	1	1	1	1	963 601 240		Filzfilter		Felt	Feutre	Filtro
1	13	1	1	1	1	1	1	1	1	1	1	1	1	1	1	1	1	1	1	010 175 050		Belüftungsventil kpl.		Air valve cpl.	Soupape d' aeration cpl.	Válvula ventilacion cpl.
1	14	1	1	1	1	1	1	1	1	1	1	1	1	1	1	1	1	1	1	965 404 911		Saugschlauch Kraftstoff		Fuel line	Conduite carb.	Tubo comb.
1	15	1	1	1	1	1	1	1	1	1	1	1	1	1	1	1	1	1	1	394 114 181		Seitenstrebe, schwarz	DOLMAR	Bracket	Support	Soporte
1	16	1	1	1	1	1	1	1	1	1	1	1	1	1	1	1	1	1	1	965 403 535		Schwingungsdämpfer		Rubber buffer	Amortisseur	Amortiguador
1	17	1	1	1	1	1	1	1	1	1	1	1	1	1	1	1	1	1	1	965 403 535		Schwingungsdämpfer		Rubber buffer	Amortisseur	Amortiguador
1	18	1	1	1	1	1	1	1	1	1	1	1	1	1	1	1	1	1	1	965 403 535		Schwingungsdämpfer		Rubber buffer	Amortisseur	Amortiguador
1	19	1	1	1	1	1	1	1	1	1	1	1	1	1	1	1	1	1	1	965 403 535		Schwingungsdämpfer		Rubber buffer	Amortisseur	Amortiguador
1	20	1	1	1	1	1	1	1	1	1	1	1	1	1	1	1	1	1	1	394 114 032		Achse für Dämpfer		Axle	Axe	Eje
1	21	1	1	1	1	1	1	1	1	1	1	1	1	1	1	1	1	1	1	394 114 032		Achse für Dämpfer		Axle	Axe	Eje
1	22	1	1	1	1	1	1	1	1	1	1	1	1	1	1	1	1	1	1	394 114 032		Achse für Dämpfer		Axle	Axe	Eje
1	23	1	1	1	1	1	1	1	1	1	1	1	1	1	1	1	1	1	1	900 005 078		Anlagescheibe		Washer	Rondelle	Arandela
1	24	1	1	1	1	1	1	1	1	1	1	1	1	1	1	1	1	1	1	900 005 078		Anlagescheibe		Washer	Rondelle	Arandela
1	25	1	1	1	1	1	1	1	1	1	1	1	1	1	1	1	1	1	1	913 455 454		Schraube	5,5x45	Screw	Vis	Tornillo
1	26	1	1	1	1	1	1	1	1	1	1	1	1	1	1	1	1	1	1	913 455 454		Schraube	5,5x45	Screw	Vis	Tornillo
1	27	1	1	1	1	1	1	1	1	1	1	1	1	1	1	1	1	1	1	913 455 454		Schraube	5,5x45	Screw	Vis	Tornillo
1	28	2	2	2	2	2	2	2	2	2	2	2	2	2	2	2	2	2	2	913 455 204		Schraube	5,5x20	Screw	Vis	Tornillo
1	29	1	1	1	1	1	1	1	1	1	1	1	1	1	1	1	1	1	1	908 305 405		Innenstern-Schraube	M5x20x40	Screw	Vis	Tornillo
1	30	1	1	1	1	1	1	1	1	1	1	1	1	1	1	1	1	1	1	394 114 750		Aufnahmetopf, schwarz		Pot	Capuchon	Pote
1	31	1	1	1	1	1	1	1	1	1	1	1	1	1	1	1	1	1	1	394 310 100		Rundumgriff kpl.		Wrap around handle	Poignée circulaire	Mango circular
1	32	1	1	1	1	1	1	1	1	1	1	1	1	1	1	1	1	1	1	394 114 190		Standfuß		Foot	Pied	Pie
1	33	1	1	1	1	1	1	1	1	1	1	1	1	1	1	1	1	1	1	980 114 987		Schild	DOLMAR	Label	Plaque	Calcomania
1	34	2	2	2	2	2	2	2	2	2	2	2	2	2	2	2	2	2	2	913 455 454		Schraube	5,5x45	Screw	Vis	Tornillo
1	35	1	1	1	1	1	1	1	1	1	1	1	1	1	1	1	1	1	1	394 114 270	Acc.	Standfuß mit Rollen kpl.		Foot cpl.	Pied cpl.	Pie cpl.
1	35						1				1								1	394 114 271	Acc.	Standfuß mit Rollen kpl.		Foot cpl.	Pied cpl.	Pie cpl.

PC-6412 S, PC-6414 S, PC-7312 S, PC-7314 S,  
 PC-8114, PC-8116, PC-6412 S (UK), PC-7314 S (UK),  
 PC-8114 (UK), PC-8116 (UK), PC-6430 (USA), PC-6435  
 (USA), PC-7330 (USA), PC-7330 C (USA), PC-7335 (USA),  
 PC-7335 C (USA), PC-8135 (USA), PC-8140 (USA)

**1**

Tankeinheit und Handgriffe  
 Tank and handle grips  
 Réservoir et poignées  
 Depósito y mangos

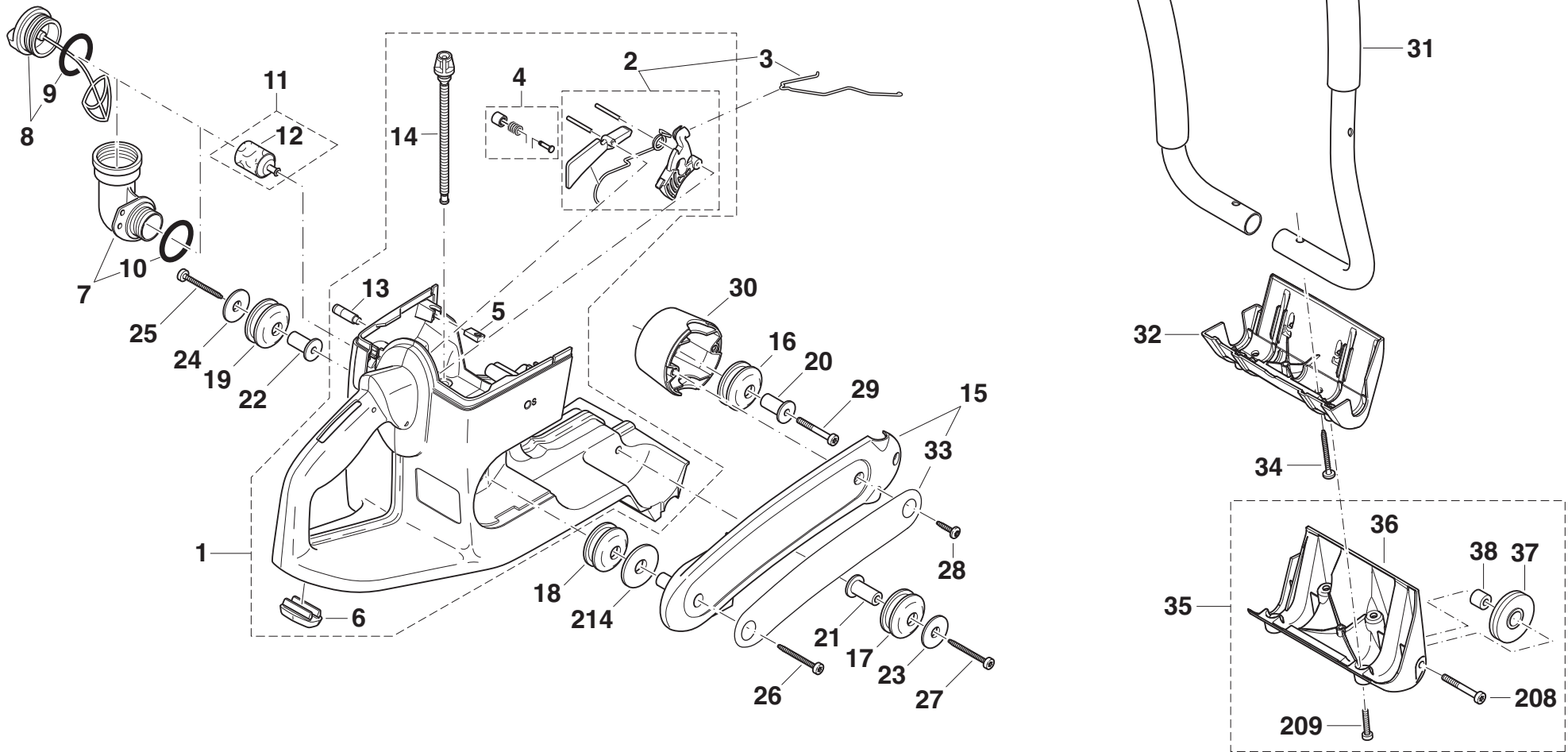

PC-6412 S, PC-6414 S, PC-7312 S, PC-7314 S,  
 PC-8114, PC-8116, PC-6412 S (UK), PC-7314 S (UK),  
 PC-8114 (UK), PC-8116 (UK), PC-6430 (USA), PC-6435  
 (USA), PC-7330 (USA), PC-7330 C (USA), PC-7335 (USA),  
 PC-7335 C (USA), PC-8135 (USA), PC-8140 (USA)

1

Tankeinheit und Handgriffe  
 Tank and handle grips  
 Réservoir et poignées  
 Depósito y mangos

**DOLMAR**  
 A member of the *Makita* Group

Seite / Page	Pos.	PC-6412 S	PC-6414 S	PC-7312 S	PC-7314 S	PC-8114	PC-8116	PC-6412 S (UK)	PC-7314 S (UK)	PC-8114 (UK)	PC-8116 (UK)	PC-6430 (USA)	PC-6435 (USA)	PC-7330 (USA)	PC-7330 C (USA)	PC-7335 (USA)	PC-7335 C (USA)	PC-8135 (USA)	PC-8140 (USA)	Teil-Nr. Part No. No. de pièce No. de pieza	Hinweise Notes Renseign. Nota	Bezeichnung	Spezifikation Specification	Description	Désignation	Denominación								
1	36						1				1									1							394 114 251		Standfuß		Foot	Pied	Pie	
1	37	2	2	2	2	2	2	2	2	2	2	2	2	2	2	2	2	2	2	2	2							394 114 230	Acc.	Rolle		Roller	Rouleau	Rueda
1	38	2	2	2	2	2	2	2	2	2	2	2	2	2	2	2	2	2	2	2	2							394 114 240	Acc.	Buchse		Bushing	Douille	Casquillo
1	208	2	2	2	2	2	2	2	2	2	2	2	2	2	2	2	2	2	2	2	2							908 006 355	Acc.	Innenstern-Schraube	M6x35	Screw	Vis	Tornillo
1	209	4	4	4	4	4	4	4	4	4	4	4	4	4	4	4	4	4	4	4	4							908 905 165		Innenstern-Schraube	5x16	Screw	Vis	Tornillo
1	214	1	1	1	1	1	1	1	1	1	1	1	1	1	1	1	1	1	1	1	1							900 005 076		Anlagescheibe		Washer	Rondelle	Arandela

PC-6412 S, PC-6414 S, PC-7312 S, PC-7314 S,  
 PC-8114, PC-8116, PC-6412 S (UK), PC-7314 S (UK),  
 PC-8114 (UK), PC-8116 (UK), PC-6430 (USA), PC-6435  
 (USA), PC-7330 (USA), PC-7330 C (USA), PC-7335 (USA),  
 PC-7335 C (USA), PC-8135 (USA), PC-8140 (USA)

**2**

Abdeckhaube, Luftfilter  
 Clutch, sprocket guard, muffler  
 Embrayage, protège-pignon, pot d'échappement  
 Embrague, Protector de piñon, silencioso

**DOLMAR**  
 A member of the *makita* Group

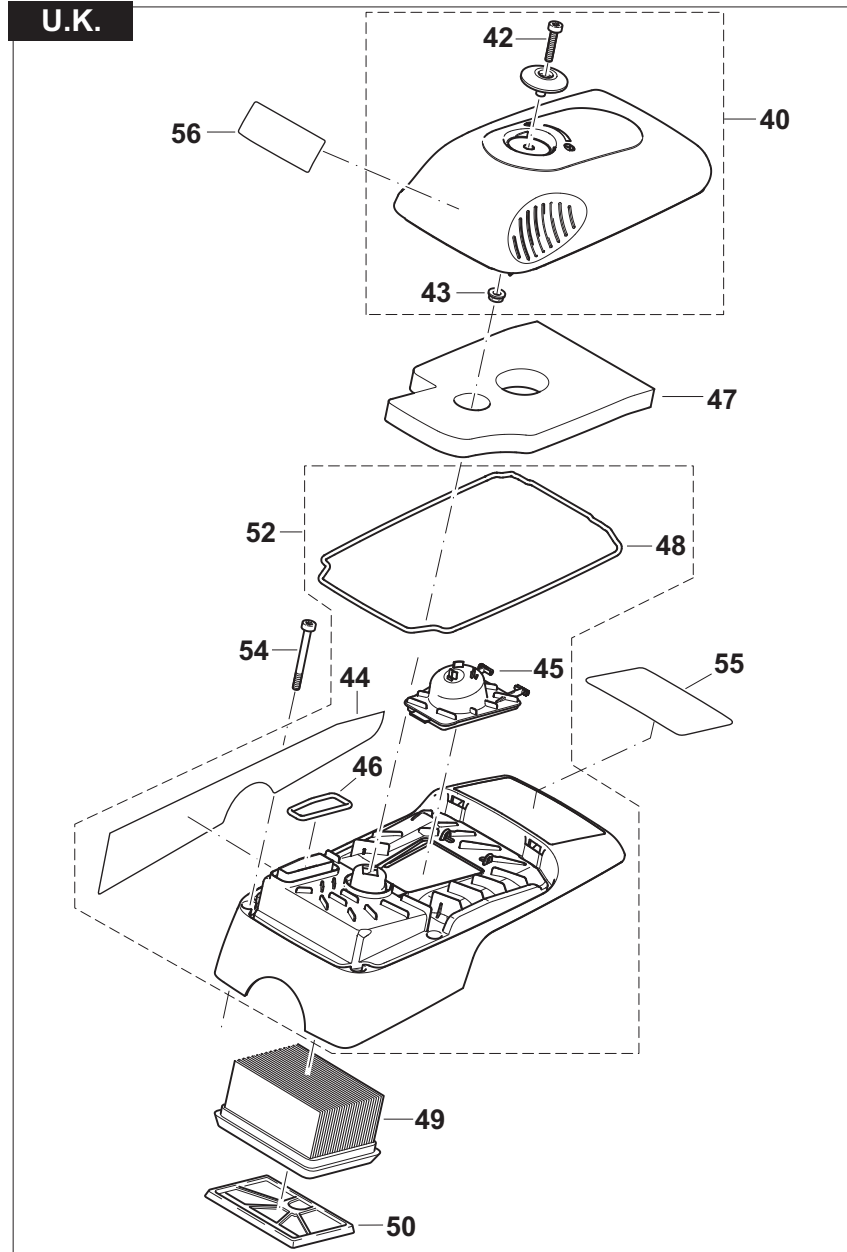
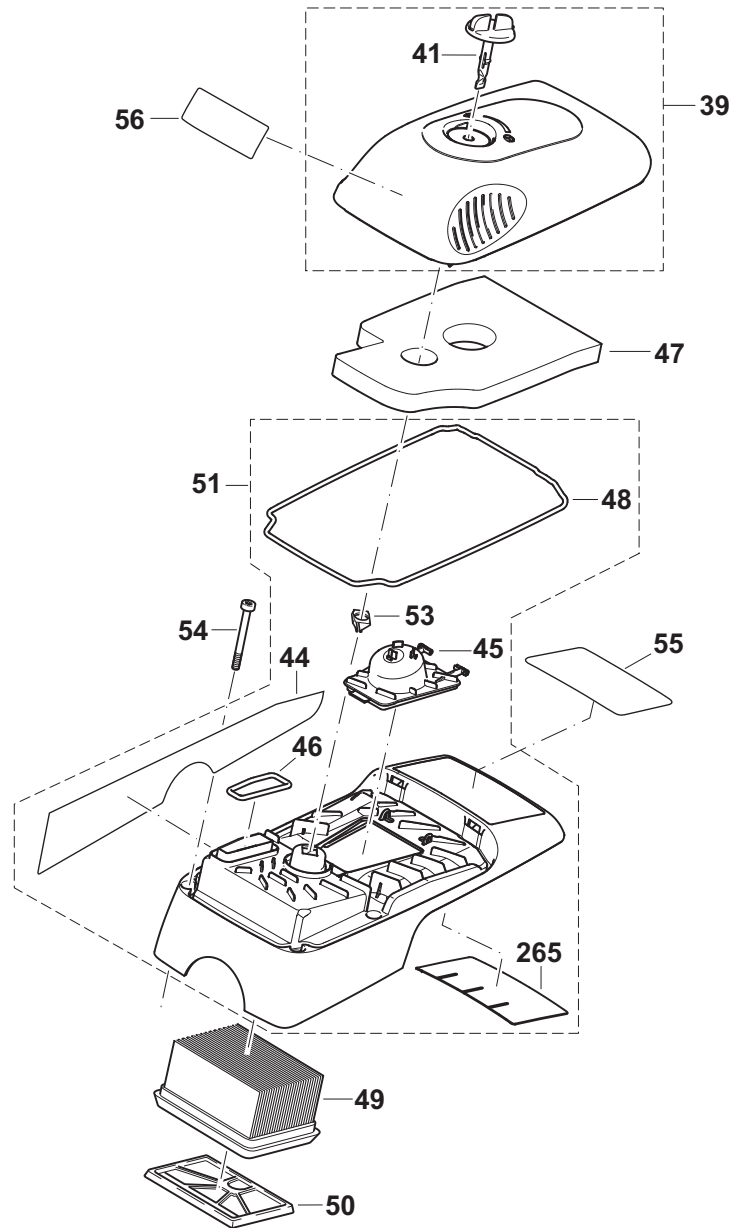

PC-6412 S, PC-6414 S, PC-7312 S, PC-7314 S,  
 PC-8114, PC-8116, PC-6412 S (UK), PC-7314 S (UK),  
 PC-8114 (UK), PC-8116 (UK), PC-6430 (USA), PC-6435  
 (USA), PC-7330 (USA), PC-7330 C (USA), PC-7335  
 (USA), PC-7335 C (USA), PC-8135 (USA), PC-8140 (USA)

2

Abdeckhaube, Luftfilter  
 Clutch, sprocket guard, muffler  
 Embrayage, protège-pignon, pot d' échappement  
 Embrague, Protector de piñon, silencioso

**DOLMAR**  
 A member of the *Makita* Group

Seite / Page	Pos.	PC-6412 S	PC-6414 S	PC-7312 S	PC-7314 S	PC-8114	PC-8116	PC-6412 S (UK)	PC-7314 S (UK)	PC-8114 (UK)	PC-8116 (UK)	PC-6430 (USA)	PC-6435 (USA)	PC-7330 (USA)	PC-7330 C (USA)	PC-7335 (USA)	PC-7335 C (USA)	PC-8135 (USA)	PC-8140 (USA)	Teil-Nr. Part No. No. de pièce No. de pieza	Hinweise Notes Renseign. Nota	Bezeichnung	Spezifikation Specification	Description	Désignation	Denominación
2	39	1	1	1	1	1	1													326 118 150		Filterdeckel kpl., rot		cover assy.	Capot cpl.	Cubierta cpl.
2	39											1	1	1	1	1	1	1	1	326 118 510	U.S.A.	Filterdeckel kpl., schwarz		cover assy.	Capot cpl.	Cubierta cpl.
2	40							1	1	1	1									326 118 160	U.K.	Filterdeckel kpl., rot		cover assy.	Capot cpl.	Cubierta cpl.
2	41	1	1	1	1	1	1					1	1	1	1	1	1	1	1	394 118 010		Bajonettverschluß		Bayonet fixing	Fermeture à baïonnette	Cierre de bayoneta
2	42							1	1	1	1									908 005 305	U.K.	Innenstern-Schraube	M5x30	Screw	Vis	Tornillo
2	43							1	1	1	1									922 105 004	U.K.	6kt-Mutter	M5	Hexagonal nut	Ecrou hexagonal	Tuerca hexagonal
2	44	1	1	1	1	1	1	1	1	1	1	1	1	1	1	1	1	1	1	980 115 269		Sicherheitsaufkleber		Safety label	Plaque	Calcomania
2	45	1	1	1	1	1	1	1	1	1	1	1	1	1	1	1	1	1	1	326 118 070		Kerzendeckel		Cover for spark plug	Couvercle p. bougie	Tapa p. bujía
2	46	1	1	1	1	1	1	1	1	1	1	1	1	1	1	1	1	1	1	326 118 050		Dichtring Hauptfilter		Packing ring	Bague-joint	Anillo de guarnición
2	47	1	1	1	1	1	1	1	1	1	1	1	1	1	1	1	1	1	1	326 173 080		Vorfilter		Prefilter	Prefiltre	Primer filtro
2	47																			326 173 090		Vorfilter kpl., geölt		Prefilter	Prefiltre	Primer filtro
2	48	1	1	1	1	1	1	1	1	1	1	1	1	1	1	1	1	1	1	326 118 020		Dichtring Filterdeckel		Packing ring	Bague-joint	Anillo de guarnición
2	49	1	1	1	1	1	1	1	1	1	1	1	1	1	1	1	1	1	1	394 173 010		Luftfiltereinsatz		Air filter	Filtre à air	Filtro de aire
2	50	1	1	1	1	1	1	1	1	1	1	1	1	1	1	1	1	1	1	394 173 020		Innenfilter		Inner filter	Filtre intérieur	Filtro de aire interior
2	51	1	1	1	1	1	1					1	1	1						326 118 082		Abdeckhaube kpl., schwarz		Hood cpl.	Capot cpl.	Tapa cpl.
2	51													1						326 118 090		Abdeckhaube kpl., schwarz	KAT	Hood cpl.	Capot cpl.	Tapa cpl.
2	52							1	1	1	1									326 118 692	U.K.	Abdeckhaube kpl., schwarz		Hood cpl.	Capot cpl.	Tapa cpl.
2	53	1	1	1	1	1	1					1	1	1	1	1	1	1	1	394 118 050		Verschluß-Unterteil		Bayonet lock	Clip de baïonnette	Alojamiento de la bayoneta
2	54	4	4	4	4	4	4	4	4	4	4	4	4	4	4	4	4	4	4	908 605 505		Innenstern-Schraube	M5x50	Screw	Vis	Tornillo
2	55	1						1												980 114 963		Schild	PC-6412 S	Label	Plaque	Calcomania
2	55		1																	980 114 964		Schild	PC-6414 S	Label	Plaque	Calcomania
2	55			1																980 114 965		Schild	PC-7312 S	Label	Plaque	Calcomania
2	55				1			1												980 114 966		Schild	PC-7314 S	Label	Plaque	Calcomania
2	55					1						1								980 115 229		Schild	PC-8114	Label	Plaque	Calcomania
2	55											1								980 115 177		Schild	PC-8116	Label	Plaque	Calcomania
2	55												1							980 115 156	U.S.A.	Schild	PC-6430	Label	Plaque	Calcomania
2	55													1						980 115 157	U.S.A.	Schild	PC-6435	Label	Plaque	Calcomania
2	55														1					980 115 158	U.S.A.	Schild	PC-7330	Label	Plaque	Calcomania
2	55															1				980 115 159	U.S.A.	Schild	PC-7335	Label	Plaque	Calcomania
2	55																	1		980 115 230	U.S.A.	Schild	PC-8135	Label	Plaque	Calcomania
2	55																		1	980 115 178	U.S.A.	Schild	PC-8140	Label	Plaque	Calcomania
2	55																			980 115 009		Schild	SC 7314	Label	Plaque	Calcomania
2	56	1	1	1	1	1	1	1	1	1	1	1	1	1	1	1	1	1	1	980 114 999		Schild	MIX	Label	Plaque	Calcomania
2	265														1					326 118 060		Hitzefolie		Thermal film	Film de Chaleur	Folio al calor

PC-6412 S, PC-6414 S, PC-7312 S, PC-7314 S,  
 PC-8114, PC-8116, PC-6412 S (UK), PC-7314 S (UK),  
 PC-8114 (UK), PC-8116 (UK), PC-6430 (USA), PC-6435  
 (USA), PC-7330 (USA), PC-7330 C (USA), PC-7335 (USA),  
 PC-7335 C (USA), PC-8135 (USA), PC-8140 (USA)

**3**

Schalldämpfer  
 Muffler  
 Pot d' échappement  
 Silencioso

**DOLMAR**  
 A member of the *Makita* Group

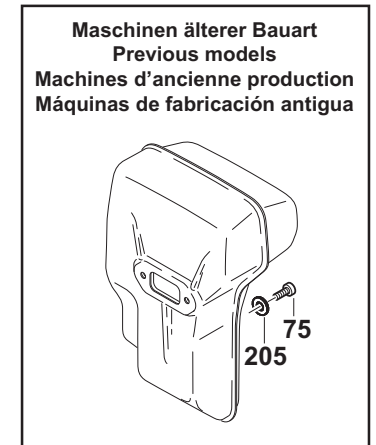
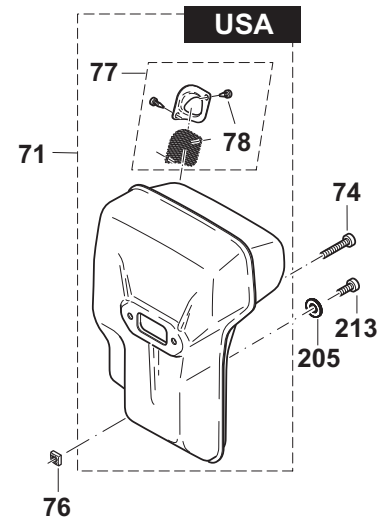
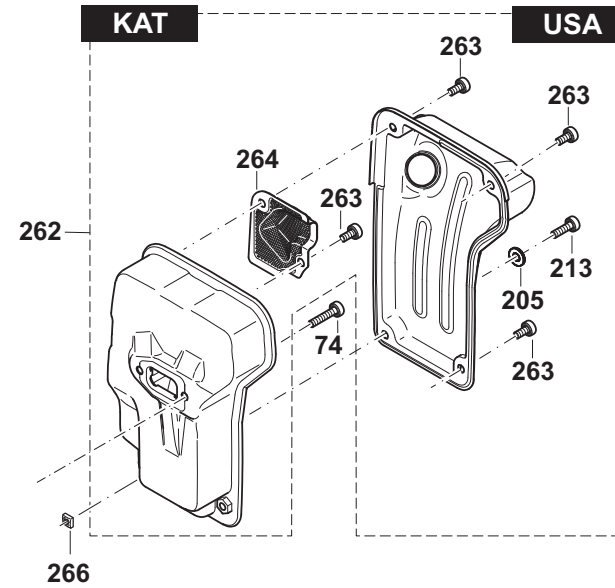
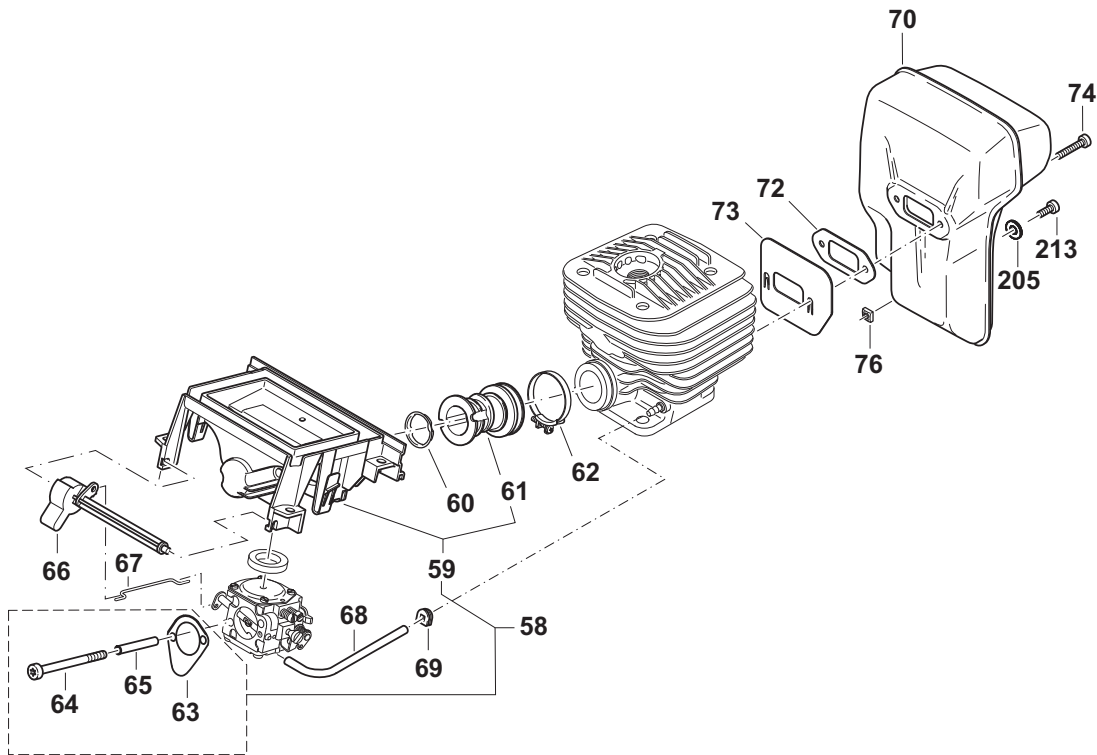



PC-6412 S, PC-6414 S, PC-7312 S, PC-7314 S,  
 PC-8114, PC-8116, PC-6412 S (UK), PC-7314 S (UK),  
 PC-8114 (UK), PC-8116 (UK), PC-6430 (USA), PC-6435  
 (USA), PC-7330 (USA), PC-7330 C (USA), PC-7335 (USA),  
 PC-7335 C (USA), PC-8135 (USA), PC-8140 (USA)

**3**

**Schalldämpfer**  
**Muffler**  
**Pot d' échappement**  
**Silencioso**

**DOLMAR**  
 A member of the **makita** Group

Seite / Page	Pos.	PC-6412 S	PC-6414 S	PC-7312 S	PC-7314 S	PC-8114	PC-8116	PC-6412 S (UK)	PC-7314 S (UK)	PC-8114 (UK)	PC-8116 (UK)	PC-6430 (USA)	PC-6435 (USA)	PC-7330 (USA)	PC-7330 C (USA)	PC-7335 (USA)	PC-7335 C (USA)	PC-8135 (USA)	PC-8140 (USA)	Teil-Nr. Part No. No. de pièce No. de pieza	Hinweise Notes Renseign. Nota	Bezeichnung	Spezifikation Specification	Description	Désignation	Denominación	
3	58	1	1	1	1	1	1	1	1	1	1	1	1	1	1	1	1	1	1	1	957 171 394		Umbausatz Ansaugkrümmer		Modification set	Jeu de modification	Juego de reconstrucción
3	59	1	1	1	1	1	1	1	1	1	1	1	1	1	1	1	1	1	1	1	394 171 051		Ansaugkrümmer kpl.		Connecting sleeve cpl.	Manchon de jonction cpl.	Manguito de conexión cpl.
3	60	1	1	1	1	1	1	1	1	1	1	1	1	1	1	1	1	1	1	1	024 131 031		Einsatz für Ansaugschlauch		Insert for suction hose	Pièce p. tuyau	Suplemento p. tubo
3	61	1	1	1	1	1	1	1	1	1	1	1	1	1	1	1	1	1	1	1	394 131 101		Ansaugschlauch		Suction line	Conduite d' aspiration	Conducto de aspiración
3	62	1	1	1	1	1	1	1	1	1	1	1	1	1	1	1	1	1	1	1	965 603 050		Schlauchschele		Hose clip	Collier de serrage	Abrazadera
3	63	1	1	1	1	1	1	1	1	1	1	1	1	1	1	1	1	1	1	1	965 518 120		Dichtung		Gasket	Joint	Junta
3	64	2	2	2	2	2	2	2	2	2	2	2	2	2	2	2	2	2	2	2	908 204 555		Innenstern-Schraube	M4x55	Screw	Vis	Tornillo
3	65	m	m	m	m	m	m	m	m	m	m	m	m	m	m	m	m	m	m	m	970 502 050		Schlauch	37mm; 1 1/2"	Tube	Gaine	Tubo
3	66	1	1	1	1	1	1	1	1	1	1	1	1	1	1	1	1	1	1	1	394 150 030		Chokewelle		Choke shaft	Axe	Eje
3	67	1	1	1	1	1	1	1	1	1	1	1	1	1	1	1	1	1	1	1	394 150 042		Chokestange		Choke shaft	Levier	Palance
3	68	m	m	m	m	m	m	m	m	m	m	m	m	m	m	m	m	m	m	m	965 452 380		Schlauch	116mm; 4 1/2"	Tube	Gaine	Tubo
3	69	1	1	1	1	1	1	1	1	1	1	1	1	1	1	1	1	1	1	1	965 401 016		Gummitülle		Rubber bush	Gaine caoutchouc	Boquilla de caucho
3	70	1	1	1	1	1	1	1	1	1	1	1	1	1	1	1	1	1	1	1	394 174 400		Schalldämpfer		Muffler	Pot d' échappement	Silencioso
3	71											1	1	1	1	1	1	1	1	1	394 174 152	U.S.A.	Schalldämpfer	USA	Muffler	Pot d' échappement	Silencioso
3	72	1	1	1	1	1	1	1	1	1	1	1	1	1	1	1	1	1	1	1	965 531 131		Dichtung		Gasket	Joint	Junta
3	73	1	1	1	1	1	1	1	1	1	1	1	1	1	1	1	1	1	1	1	394 174 051		Abschirmblech		Cover plate	Tôle de protection	Chapa deflectora
3	74	2	2	2	2	2	2	2	2	2	2	2	2	2	2	2	2	2	2	2	908 405 205		Innenstern-Schraube	M5x20	Screw	Vis	Tornillo
3	75	1	1	1	1			1	1			1	1	1	1						908 905 125		Innen-6kt-Schraube	5x12	Screw	Vis	Tornillo
3	76	1	1	1	1	1	1	1	1	1	1	1	1	1	1	1	1	1	1	1	038 111 060	2007-03 =>	4kt-Mutter	M5, SW10	Square nut	Ecrou carré	Tuerca cuadr.
3	76	1	1	1	1			1	1			1	1	1	1						921 905 004	=> 2007-03	4kt-Mutter	M5, SW8	Square nut	Ecrou carré	Tuerca cuadr.
3	77											1	1	1	1	1	1	1	1	1	394 174 142	U.S.A.	Funkenschutzsieb		Spark arrestor screen	Tamis	Tamiz
3	78											2	2	2	2	2	2	2	2	2	915 035 120	U.S.A.	Schraube		Screw	Vis	Tornillo
3	205	1	1	1	1	1	1	1	1	1	1	1	1	1	1	1	1	1	1	1	928 405 000		Spannscheibe		Disc	Disque	Arandela
3	213	1	1	1	1	1	1	1	1	1	1	1	1	1	1	1	1	1	1	1	908 005 125		Innenstern-Schraube	M5x12	Screw	Vis	Tornillo
3	262																				394 174 550		Schalldämpfer	KAT	Muffler	Pot d' échappement	Silencioso
3	263														4	4					908 005 095		Schraube	M5x9	Screw	Vis	Tornillo
3	264														1	1					394 174 340		Funkenschutzsieb	KAT	Spark arrestor screen	Tamis	Tamiz
3	266														1	1					038 111 060		4kt-Mutter	M5, SW10	Square nut	Ecrou carré	Tuerca cuadr.

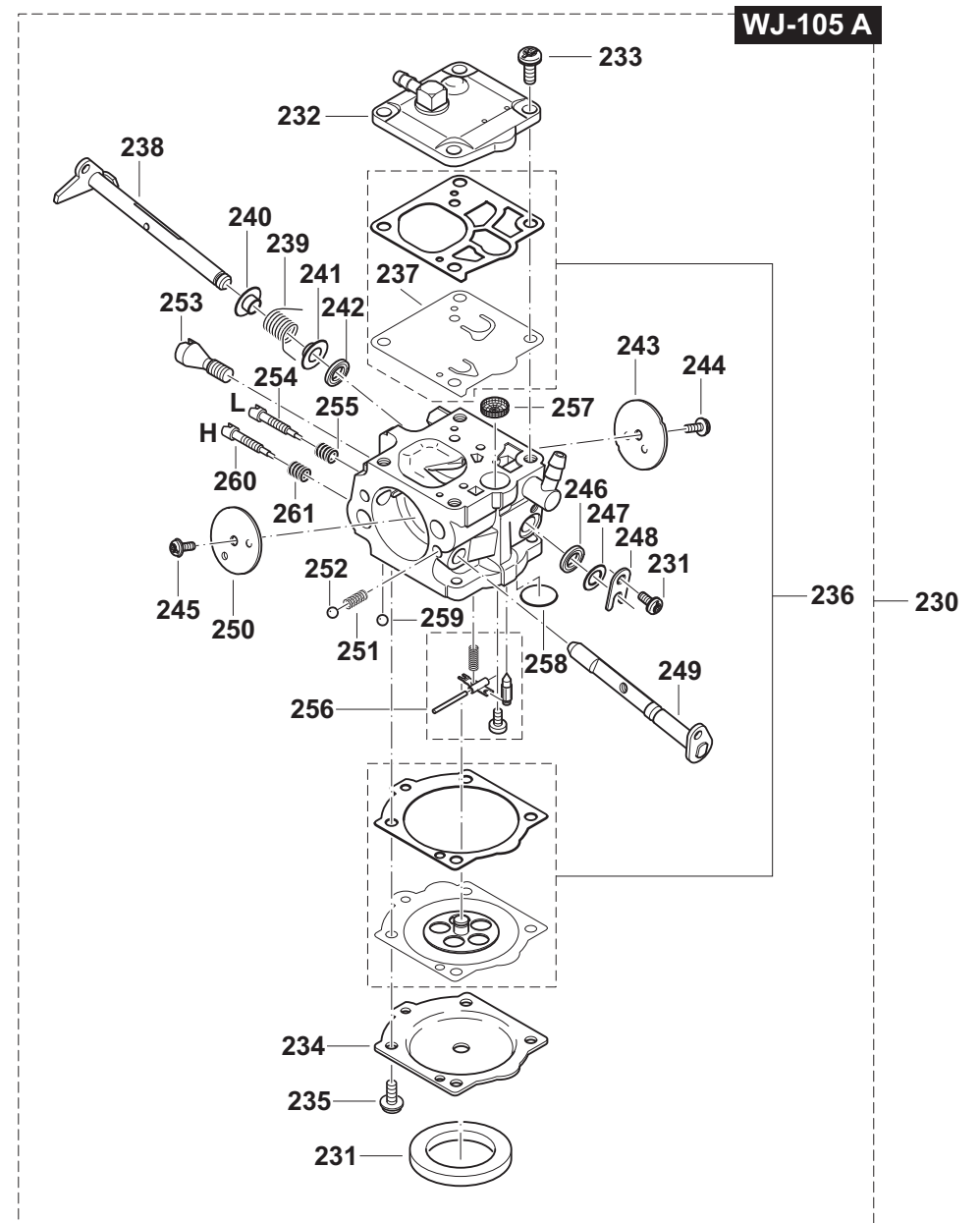
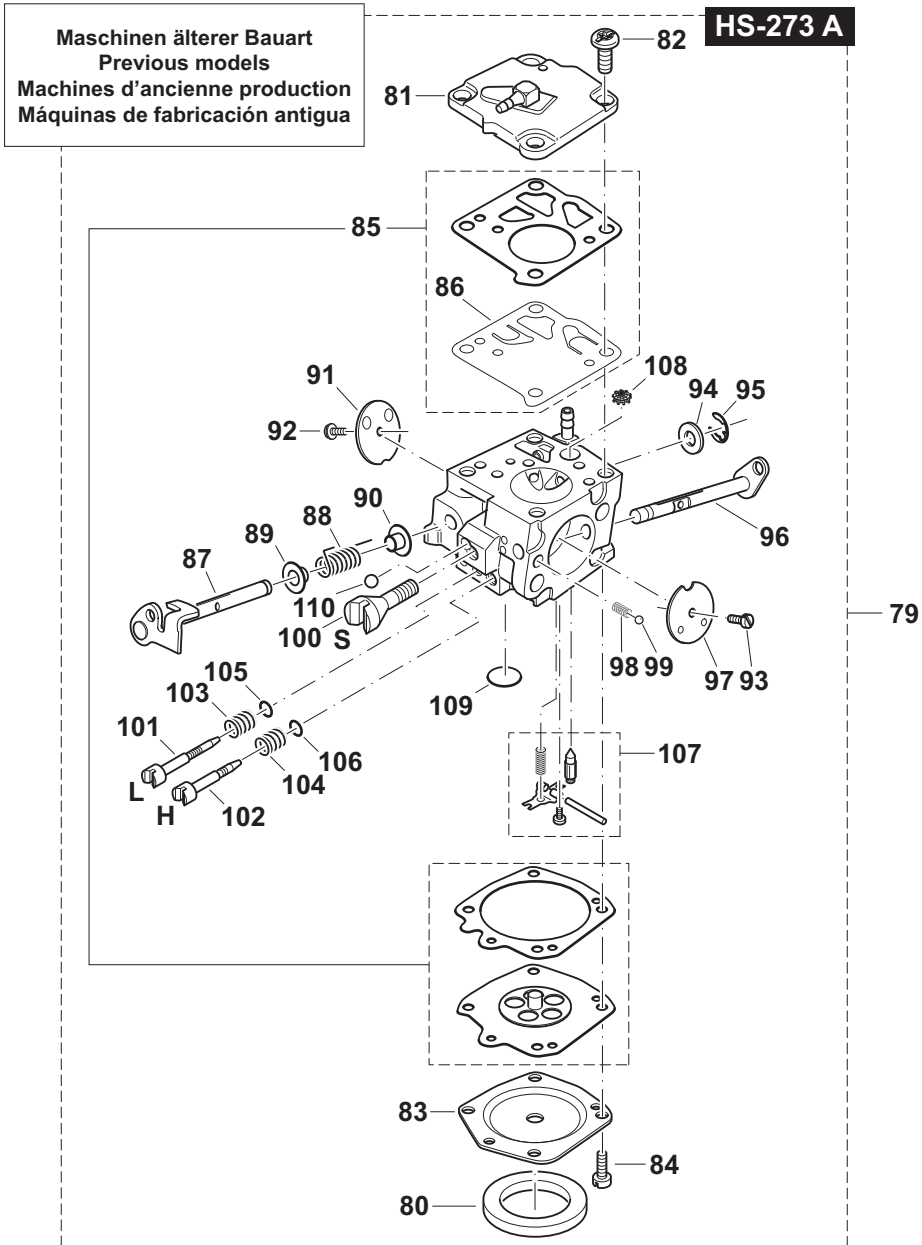

PC-6412 S, PC-6414 S, PC-7312 S, PC-7314 S,  
 PC-8114, PC-8116, PC-6412 S (UK), PC-7314 S (UK),  
 PC-8114 (UK), PC-8116 (UK), PC-6430 (USA), PC-6435  
 (USA), PC-7330 (USA), PC-7330 C (USA), PC-7335 (USA),  
 PC-7335 C (USA), PC-8135 (USA), PC-8140 (USA)

4

Vergaser  
 Carburator  
 Carburateur  
 Carburador

**DOLMAR**  
 A member of the *Makita* Group

Seite / Page	Pos.	PC-6412 S	PC-6414 S	PC-7312 S	PC-7314 S	PC-8114	PC-8116	PC-6412 S (UK)	PC-7314 S (UK)	PC-8114 (UK)	PC-8116 (UK)	PC-6430 (USA)	PC-6435 (USA)	PC-7330 (USA)	PC-7330 C (USA)	PC-7335 (USA)	PC-7335 C (USA)	PC-8135 (USA)	PC-8140 (USA)	Teil-Nr. Part No. No. de pièce No. de pieza	Hinweise Notes Renseign. Nota	Bezeichnung	Spezifikation Specification	Description	Désignation	Denominación
4	79	1	1	1	1			1	1			1	1	1						394 150 050		Vergaser mit Dichtung	HS-273 A	Carburator	Carburateur	Carburador
4	80	1	1	1	1			1	1			1	1	1						965 402 970		Dichtung		Gasket	Joint	Junta
4	81	1	1	1	1			1	1			1	1	1						394 150 160		Pumpendeckel kpl.		Pump cover cpl.	Couvercle de pompe cpl.	Tapa de bomba cpl.
4	82	4	4	4	4			4	4			4	4	4						394 150 170		Schraube		Screw	Vis	Tornillo
4	83	1	1	1	1			1	1			1	1	1						394 150 120		Membrandeckel		Diaphragm cover	Couvercle de membrane	Tapa de membrana
4	84	4	4	4	4			4	4			4	4	4						001 150 520		Schraube		Screw	Vis	Tornillo
4	85	1	1	1	1			1	1			1	1	1						957 150 100		Membransatz		Set diaphragm / gaskets	Jeu de membranes / joints	Juego membranas / juntas
4	86	1	1	1	1			1	1			1	1	1						113 150 150		Pumpenmembrane, Gummi		Pump diaphragm, rubber	Membr. de pompe	Membr. d. la bomba
4	87	1	1	1	1			1	1			1	1	1						394 150 300		Drosselklappenwelle		Throttle shaft	Axe clapet d'étranglem.	Eje válvula regulador
4	88	1	1	1	1			1	1			1	1	1						394 150 310		Drehfeder		Spring	Ressort	Resorte
4	89	1	1	1	1			1	1			1	1	1						144 151 315		Buchse		Bushing	Douille	Casquillo
4	90	1	1	1	1			1	1			1	1	1						144 151 315		Buchse		Bushing	Douille	Casquillo
4	91	1	1	1	1			1	1			1	1	1						144 151 320		Drosselklappe		Throttle shutter	Clapet d'étranglement	Válvula reguladora
4	92	1	1	1	1			1	1			1	1	1						001 150 650		Schraube		Screw	Vis	Tornillo
4	93	1	1	1	1			1	1			1	1	1						001 150 650		Schraube		Screw	Vis	Tornillo
4	94	1	1	1	1			1	1			1	1	1						122 151 400		Scheibe		Disc	Disque	Disco
4	95	1	1	1	1			1	1			1	1	1						100 150 350		Sicherungsscheibe		Safety washer	Rondelle sécurité	Arandela seguridad
4	96	1	1	1	1			1	1			1	1	1						394 150 250		Chokewelle		Choke shaft	Axe pour clapet d'air	Eje para válvula de aire
4	97	1	1	1	1			1	1			1	1	1						113 150 261		Chokeklappe		Choke shutter	Clapet d'air	Válvula de aire
4	98	1	1	1	1			1	1			1	1	1						101 150 080		Arretierfeder		Locking spring	Ressort d'arrêt	Resorte de tope
4	99	1	1	1	1			1	1			1	1	1						113 150 380		Arretierkugel		Locking ball	Bille d'arrêt	Bola de tope
4	100	1	1	1	1			1	1			1	1	1						394 150 570		Leerlauf-Anschlagschraube	S	Idle stop screw	Vis de butée de ralenti	Tornillo de tope
4	101	1	1	1	1			1	1			1	1	1						394 150 470		Leerlauf-Stellschraube	L	Idle adjustment screw	Vis de régl. de ralenti	Tornillo regulador
4	102	1	1	1	1			1	1			1	1	1						394 150 510		Vollgas-Stellschraube	H	Main adjustm. screw	Vis de régl. plein gaz	Tornillo regulador
4	103	1	1	1	1			1	1			1	1	1						144 151 480		Feder	(L)	Spring	Ressort	Resorte
4	104	1	1	1	1			1	1			1	1	1						144 151 480		Feder	(L)	Spring	Ressort	Resorte
4	105	1	1	1	1			1	1			1	1	1						394 150 500		O-Ring		Packing ring	Bague-joint	Anillo de guarnición
4	106	1	1	1	1			1	1			1	1	1						394 150 500		O-Ring		Packing ring	Bague-joint	Anillo de guarnición
4	107	1	1	1	1			1	1			1	1	1						957 150 160		Satz Steuerteile		Set of control parts	Jeu de pièces de comm.	Juego piezas de mando
4	108	1	1	1	1			1	1			1	1	1						394 150 180		Sieb		Screen	Tamis	Tamiz
4	109	1	1	1	1			1	1			1	1	1						113 150 040		Verschlußscheibe	ø 9 mm	Cover disc	Disque de fermeture	Disco de sierre
4	110	1	1	1	1			1	1			1	1	1						001 150 510		Arretierkugel		Locking ball	Bille d'arrêt	Bola de tope
4	230	1	1	1	1	1	1	1	1	1	1	1	1	1	1	1	1	1	1	394 151 051		Vergaser mit Dichtung	WJ-105 A	Carburator	Carburateur	Carburador
4	231	1	1	1	1	1	1	1	1	1	1	1	1	1	1	1	1	1	1	965 402 970		Dichtung		Gasket	Joint	Junta

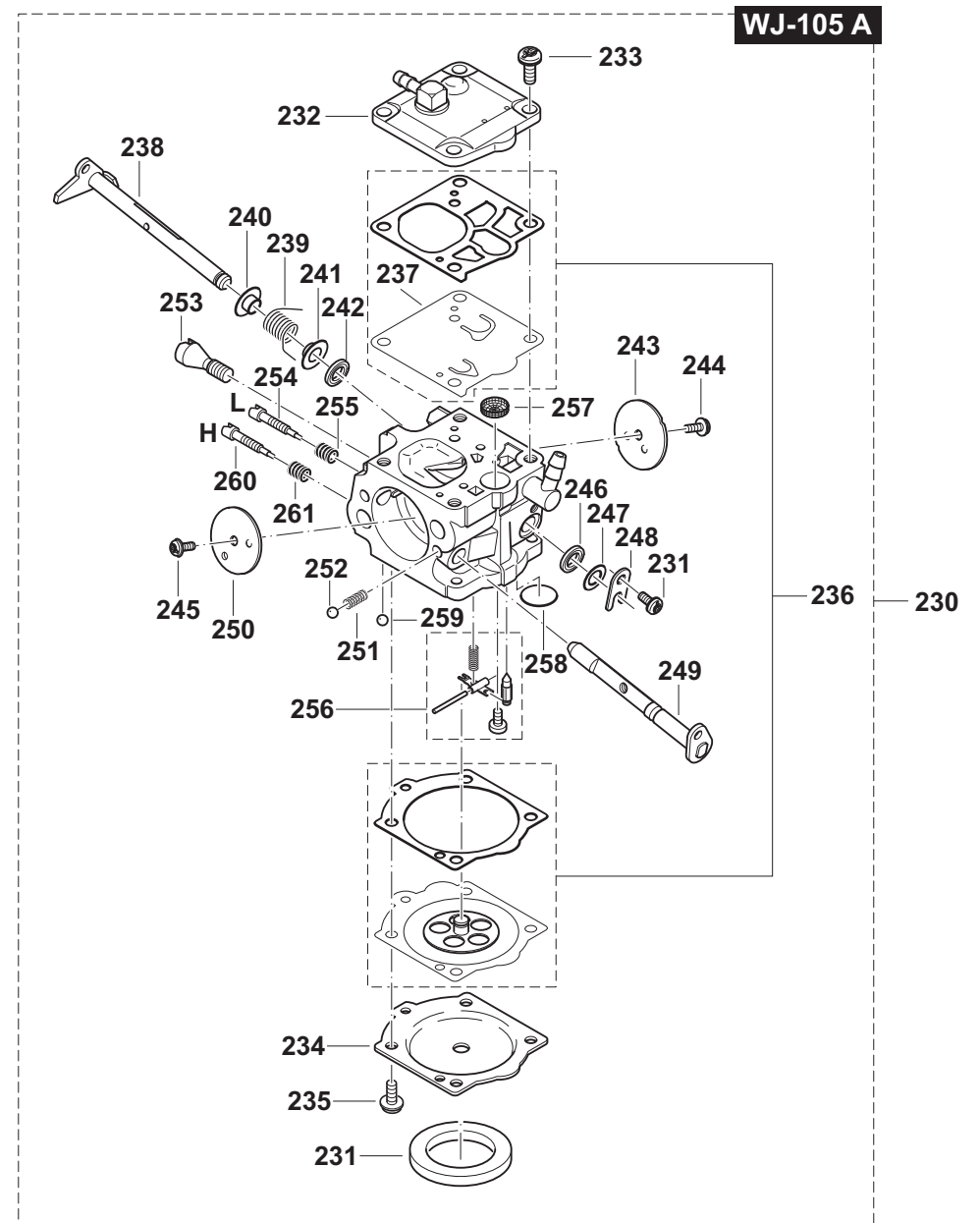
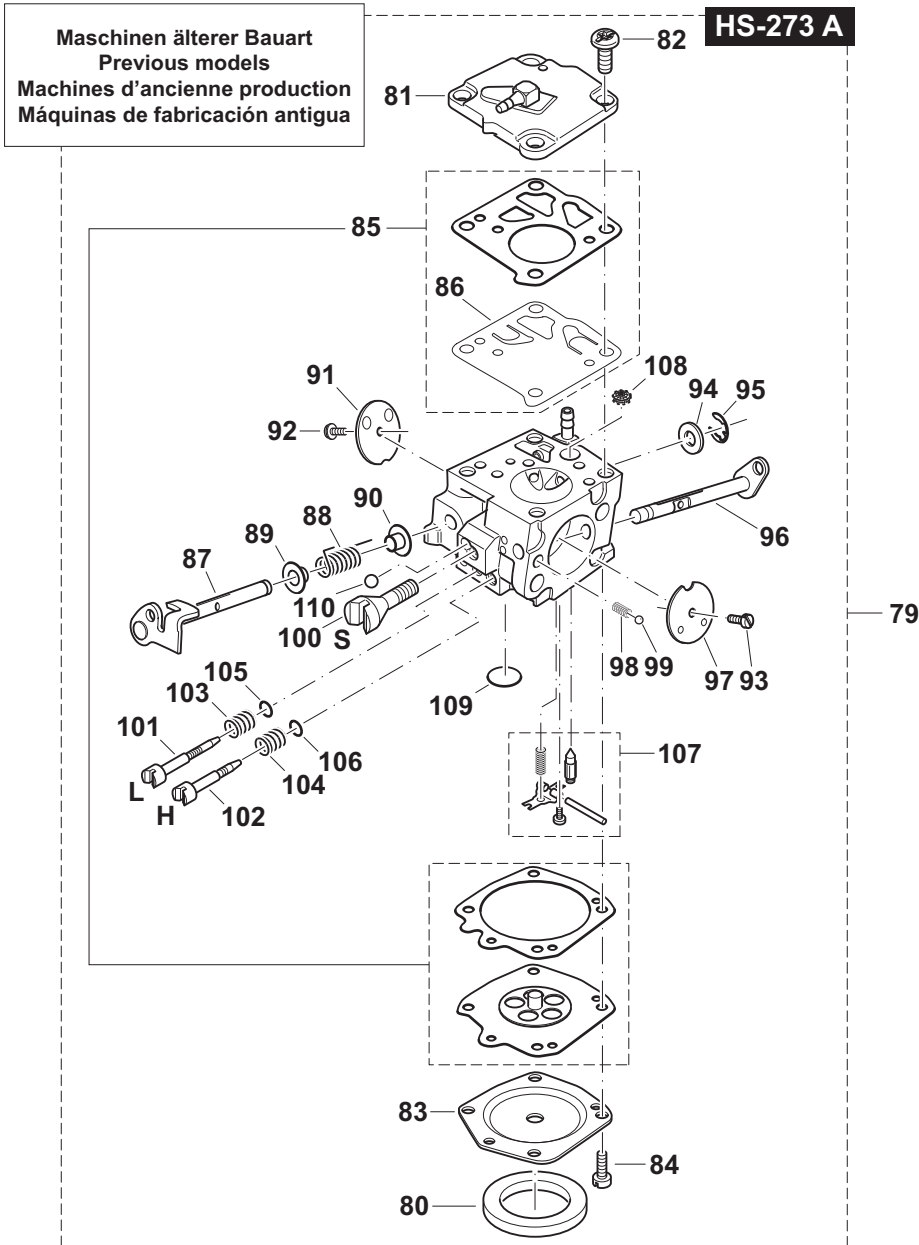

PC-6412 S, PC-6414 S, PC-7312 S, PC-7314 S,  
 PC-8114, PC-8116, PC-6412 S (UK), PC-7314 S (UK),  
 PC-8114 (UK), PC-8116 (UK), PC-6430 (USA), PC-6435  
 (USA), PC-7330 (USA), PC-7330 C (USA), PC-7335 (USA),  
 PC-7335 C (USA), PC-8135 (USA), PC-8140 (USA)

4

Vergaser  
 Carburator  
 Carburateur  
 Carburador

**DOLMAR**  
 A member of the **Makita** Group

Seite / Page	Pos.	PC-6412 S	PC-6414 S	PC-7312 S	PC-7314 S	PC-8114	PC-8116	PC-6412 S (UK)	PC-7314 S (UK)	PC-8114 (UK)	PC-8116 (UK)	PC-6430 (USA)	PC-6435 (USA)	PC-7330 (USA)	PC-7330 C (USA)	PC-7335 (USA)	PC-7335 C (USA)	PC-8135 (USA)	PC-8140 (USA)	Teil-Nr. Part No. No. de pièce No. de pieza	Hinweise Notes Renseign. Nota	Bezeichnung	Spezifikation Specification	Description	Désignation	Denominación	
4	232	1	1	1	1	1	1	1	1	1	1	1	1	1	1	1	1	1	1	1	394 151 160		Pumpendeckel kpl.		Pump cover cpl.	Couvercle de pompe cpl.	Tapa de bomba cpl.
4	233	4	4	4	4	4	4	4	4	4	4	4	4	4	4	4	4	4	4	4	144 150 170		Schraube		Screw	Vis	Tornillo
4	234	1	1	1	1	1	1	1	1	1	1	1	1	1	1	1	1	1	1	1	394 151 120		Membrandeckel		Diaphragm cover	Couvercle de membrane	Tapa de membrana
4	235	4	4	4	4	4	4	4	4	4	4	4	4	4	4	4	4	4	4	4	378 151 220		Schraube		Screw	Vis	Tornillo
4	236	1	1	1	1	1	1	1	1	1	1	1	1	1	1	1	1	1	1	1	957 151 180		Membransatz		Set diaphragm / gaskets	Jeu de membranes / joints	Juego membranas / juntas
4	237	1	1	1	1	1	1	1	1	1	1	1	1	1	1	1	1	1	1	1	394 151 150		Pumpenmembrane, Gummi		Pump diaphragm	Membr. de pompe	Membr. d. la bomba
4	238	1	1	1	1	1	1	1	1	1	1	1	1	1	1	1	1	1	1	1	394 151 300		Drosselklappenwelle		Throttle shaft	Axe clapet d' étranglement.	Eje válvula regulador
4	239	1	1	1	1	1	1	1	1	1	1	1	1	1	1	1	1	1	1	1	394 151 310		Drehfeder		Spring	Ressort	Resorte
4	240	1	1	1	1	1	1	1	1	1	1	1	1	1	1	1	1	1	1	1	394 151 315		Buchse		Bushing	Douille	Casquillo
4	241	1	1	1	1	1	1	1	1	1	1	1	1	1	1	1	1	1	1	1	394 151 315		Buchse		Bushing	Douille	Casquillo
4	242	1	1	1	1	1	1	1	1	1	1	1	1	1	1	1	1	1	1	1	394 151 330		Dichtring		Packing ring	Bague-joint	Anillo de guarnición
4	243	1	1	1	1	1	1	1	1	1	1	1	1	1	1	1	1	1	1	1	394 151 320		Drosselklappe		Throttle shutter	Clapet d' étranglement	Válvula reguladora
4	244	1	1	1	1	1	1	1	1	1	1	1	1	1	1	1	1	1	1	1	394 151 650		Schraube		Screw	Vis	Tornillo
4	245	1	1	1	1	1	1	1	1	1	1	1	1	1	1	1	1	1	1	1	394 151 660		Schraube		Screw	Vis	Tornillo
4	246	1	1	1	1	1	1	1	1	1	1	1	1	1	1	1	1	1	1	1	394 151 330		Dichtring		Packing ring	Bague-joint	Anillo de guarnición
4	247	1	1	1	1	1	1	1	1	1	1	1	1	1	1	1	1	1	1	1	394 151 400		Scheibe		Disc	Disque	Disco
4	248	1	1	1	1	1	1	1	1	1	1	1	1	1	1	1	1	1	1	1	108 151 350		Wellensicherung		Shaft clip	Tôle de sécurité	Pieza seguridad árbol
4	249	1	1	1	1	1	1	1	1	1	1	1	1	1	1	1	1	1	1	1	394 151 250		Chokewelle		Shaft	Axe	Eje
4	250	1	1	1	1	1	1	1	1	1	1	1	1	1	1	1	1	1	1	1	394 151 260		Chokeklappe		Choke shutter	Clapet d' air	Válvula de aire
4	251	1	1	1	1	1	1	1	1	1	1	1	1	1	1	1	1	1	1	1	118 151 160		Arretierfeder		Locking spring	Ressort d' arrêt	Resorte de tope
4	252	1	1	1	1	1	1	1	1	1	1	1	1	1	1	1	1	1	1	1	118 151 170		Arretierkugel		Locking ball	Bille d' arrêt	Bola de tope
4	253	1	1	1	1	1	1	1	1	1	1	1	1	1	1	1	1	1	1	1	394 151 570		Leerlauf-Anschlagschraube	S	Idle stop screw	Vis de butée de ralenti	Tornillo de tope
4	254	1	1	1	1	1	1	1	1	1	1	1	1	1	1	1	1	1	1	1	394 151 470		Leerlauf-Stellschraube	L	Idle adjustment screw	Vis de régl. de ralenti	Tornillo regulador
4	255	1	1	1	1	1	1	1	1	1	1	1	1	1	1	1	1	1	1	1	021 151 480		Feder	L	Spring	Ressort	Resorte
4	256	1	1	1	1	1	1	1	1	1	1	1	1	1	1	1	1	1	1	1	957 151 190		Satz Steuerteile		Control parts	Pièces de comm.	Piezas de mando
4	257	1	1	1	1	1	1	1	1	1	1	1	1	1	1	1	1	1	1	1	021 151 180		Sieb		Screen	Tamis	Tamiz
4	258	1	1	1	1	1	1	1	1	1	1	1	1	1	1	1	1	1	1	1	394 151 040		Verschlusscheibe		Cover disc	Disque de fermeture	Disco de sierre
4	259	1	1	1	1	1	1	1	1	1	1	1	1	1	1	1	1	1	1	1	394 151 510		Sicherungseinsatz		Locking ball	Bille d' arrêt	Bola de tope
4	260	1	1	1	1	1	1	1	1	1	1	1	1	1	1	1	1	1	1	1	001 151 450		Vollgas-Stellschraube	H	Main adjustm. screw	Vis de régl. plein gaz	Tornillo regulador
4	261	1	1	1	1	1	1	1	1	1	1	1	1	1	1	1	1	1	1	1	021 151 480		Feder	L	Spring	Ressort	Resorte

PC-6412 S, PC-6414 S, PC-7312 S, PC-7314 S,  
PC-8114, PC-8116, PC-6412 S (UK), PC-7314 S (UK),  
PC-8114 (UK), PC-8116 (UK), PC-6430 (USA), PC-6435  
(USA), PC-7330 (USA), PC-7330 C (USA), PC-7335 (USA),  
PC-7335 C (USA), PC-8135 (USA), PC-8140 (USA)

**5**

Anwerfvorrichtung, Magnetzünd  
Starter assy., ignition assy.  
Dispositif de démarrage, volant magnétique  
Dispositivo arranque, volante magnético

**DOLMAR**  
A member of the *makita* Group

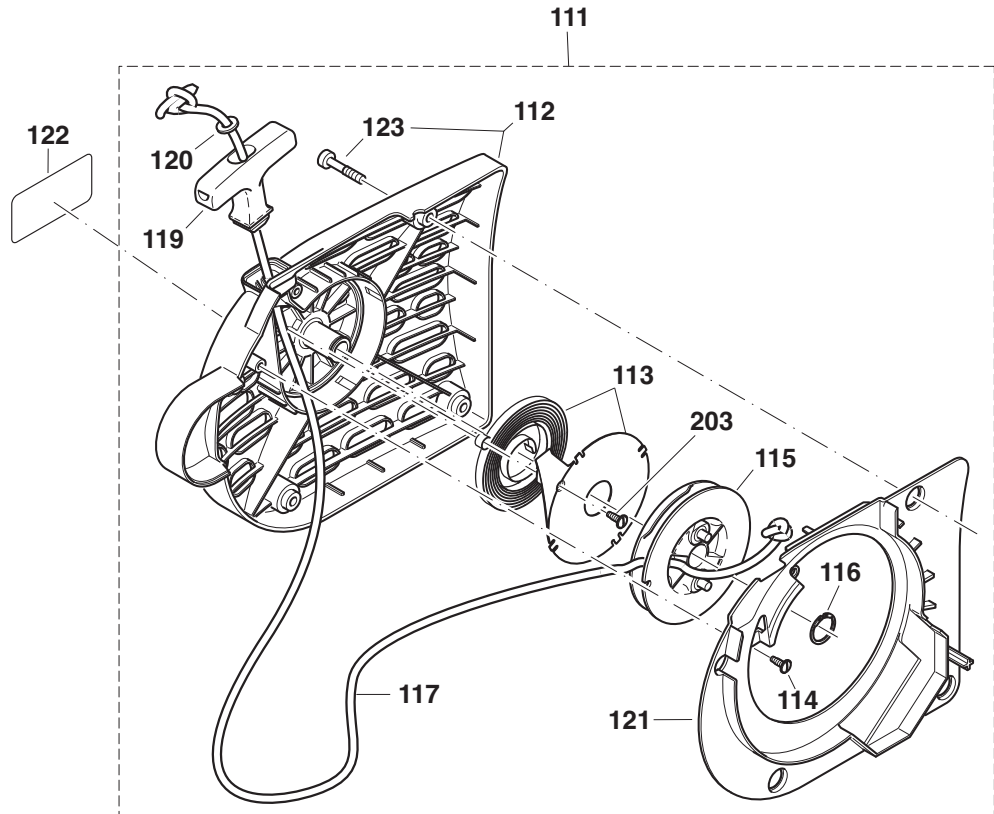

Maschinen älterer Bauart  
Previous models  
Machines d'ancienne production  
Máquinas de fabricación antigua

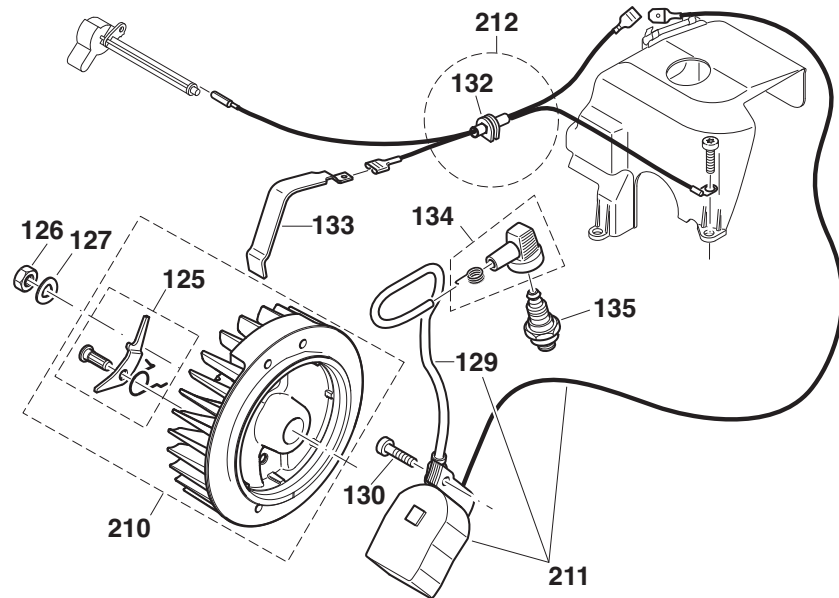
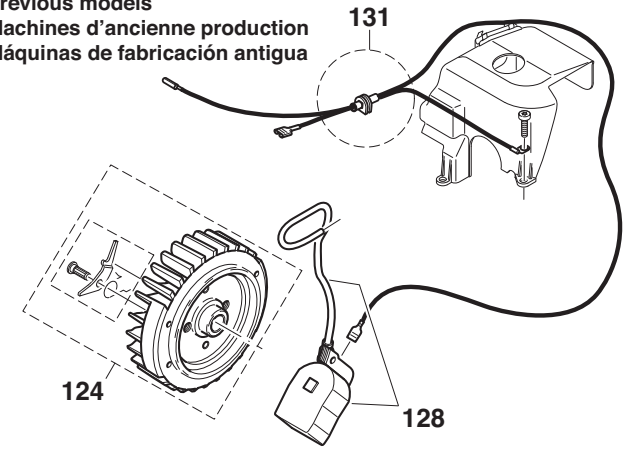

PC-6412 S, PC-6414 S, PC-7312 S, PC-7314 S,  
 PC-8114, PC-8116, PC-6412 S (UK), PC-7314 S (UK),  
 PC-8114 (UK), PC-8116 (UK), PC-6430 (USA), PC-6435  
 (USA), PC-7330 (USA), PC-7330 C (USA), PC-7335  
 (USA), PC-7335 C (USA), PC-8135 (USA), PC-8140 (USA)

**5**

Anwerfvorrichtung, Magnetzünd  
 Starter assy., ignition assy.  
 Dispositif de démarrage, volant magnétique  
 Dispositivo arranque, volante magnético



Seite / Page	Pos.	PC-6412 S	PC-6414 S	PC-7312 S	PC-7314 S	PC-8114	PC-8116	PC-6412 S (UK)	PC-7314 S (UK)	PC-8114 (UK)	PC-8116 (UK)	PC-6430 (USA)	PC-6435 (USA)	PC-7330 (USA)	PC-7330 C (USA)	PC-7335 (USA)	PC-7335 C (USA)	PC-8135 (USA)	PC-8140 (USA)	Teil-Nr. Part No. No. de pièce No. de pieza	Hinweise Notes Renseign. Nota	Bezeichnung	Spezifikation Specification	Description	Désignation	Denominación
5	111	1	1	1	1	1	1	1	1	1	1	1	1	1	1	1	1	1	1	394 112 172		Anwerfvorrichtung kpl., rot, schw.Seil		Starter assy.	Dispos. de démarrage cpl.	Dispos. de arranque cpl.
5	112	1	1	1	1	1	1	1	1	1	1	1	1	1	1	1	1	1	1	394 112 161		Startergehäuse, rot		Housing	Carter	Cárter
5	113	1	1	1	1	1	1	1	1	1	1	1	1	1	1	1	1	1	1	394 163 020		Rückholfeder im Gehäuse		Rewind spring	Ressort de rappel	Resorte retenc.
5	114	2	2	2	2	2	2	2	2	2	2	2	2	2	2	2	2	2	2	915 135 100		Schneidschraube	3,5x9,5	Screw	Vis	Tornillo
5	115	1	1	1	1	1	1	1	1	1	1	1	1	1	1	1	1	1	1	394 162 040		Seiltrommel		Cable drum	Tambour de câble	Tambour para cordón
5	116	1	1	1	1	1	1	1	1	1	1	1	1	1	1	1	1	1	1	929 314 100		Sicherungsring		Snap ring	Circlip	Anillo seguridad
5	117	1	1	1	1	1	1	1	1	1	1	1	1	1	1	1	1	1	1	394 164 020		Anwerfseil schwarz	ø4 x 1000mm	Starter rope black	Câble de démarrage noir	Cordón de arranque negro
5	117	1	1	1	1	1	1	1	1	1	1	1	1	1	1	1	1	1	1	985 000 165		Anwerfseil	ø4 x 100m	Starter rope	Câble de démarrage	Cordón de arranque
5	119	1	1	1	1	1	1	1	1	1	1	1	1	1	1	1	1	1	1	001 161 020		Anwerfgriff		Starter grip	Poignée de lancement	Tirador de arranque
5	120	1	1	1	1	1	1	1	1	1	1	1	1	1	1	1	1	1	1	928 405 000		Spannscheibe		Disc	Disque	Arandela
5	121	1	1	1	1	1	1	1	1	1	1	1	1	1	1	1	1	1	1	394 112 141		Lufführung		Air guide plate	Guide d'air	Conducto de aire
5	122	1	1	1	1	1	1	1	1	1	1	1	1	1	1	1	1	1	1	980 114 208		Schild	DOLMAR	Label	Plaque	Calcomania
5	123	4	4	4	4	4	4	4	4	4	4	4	4	4	4	4	4	4	4	908 605 205		Innenstern-Schlitz-Schraube	M5x20	Screw	Vis	Tornillo
5	124	1	1	1	1			1	1			1	1	1						394 141 030	=> 4/05	Polrad kpl.		Flywheel assy.	Roue polaire cpl.	Volante encendido
5	125	2	2	2	2	2	2	2	2	2	2	2	2	2	2	2	2	2	2	031 166 010		Anwerfklinke kpl.		Starter ratchet cpl.	Cliquet cpl.	Trinquete arranque cpl.
5	126	1	1	1	1	1	1	1	1	1	1	1	1	1	1	1	1	1	1	920 208 024		6kt-Mutter	M8x1	Hexagonal nut	Ecrou hexagonal	Tuerca hexagonal
5	127	1	1	1	1	1	1	1	1	1	1	1	1	1	1	1	1	1	1	926 208 001		Federscheibe	B8 DIN137	Spring washer	Rondelle élastique	Disco amortiguador
5	128	1	1	1	1			1	1			1	1	1						394 143 013	=> 4/05	Magnetzünd		Ignition coil	Bobine d' allumage	Bobina encendido
5	129	m	m	m	m	m	m	m	m	m	m	m	m	m	m	m	m	m	m	970 310 200		Zündleitung	360mm; 141/8"	Ignition cable	Câble d' allumage	Cable encendido
5	130	2	2	2	2	2	2	2	2	2	2	2	2	2	2	2	2	2	2	908 605 205		Innenstern-Schlitz-Schraube	M5x20	Screw	Vis	Tornillo
5	131	1	1	1	1			1	1			1	1	1						965 605 433	=> 4/05	Kabel mit Stecker		Cable with plug	Câble avec prise	Cable con enchufe
5	132	1	1	1	1	1	1	1	1	1	1	1	1	1	1	1	1	1	1	965 401 016		Gummitülle		Rubber bush	Gaine caoutchouc	Boquilla de caucho
5	133	1	1	1	1	1	1	1	1	1	1	1	1	1	1	1	1	1	1	394 146 013		Kontaktfeder		Contact spring	Ressort de contact	Resorte de contacto
5	134	1	1	1	1	1	1	1	1	1	1	1	1	1	1	1	1	1	1	957 604 240		Zündkerzenstecker kpl.		Spark plug cap cpl.	Fiche de bougie, cpl.	Tapa de bujia cpl.
5	135	1	1	1	1	1	1	1	1	1	1	1	1	1	1	1	1	1	1	965 603 021		Zündkerze		Spark plug	Bougie	Bujia
5	203	1	1	1	1	1	1	1	1	1	1	1	1	1	1	1	1	1	1	915 135 100		Schneidschraube	3,5x9,5	Screw	Vis	Tornillo
5	210	1	1	1	1	1	1	1	1	1	1	1	1	1	1	1	1	1	1	394 141 050	5/05 =>	Polrad kpl.		Flywheel assy.	Roue polaire cpl.	Volante encendido
5	211	1	1	1	1	1	1	1	1	1	1	1	1	1	1	1	1	1	1	394 143 030	5/05 =>	Magnetzünd		Ignition coil	Bobine d' allumage	Bobina encendido
5	212	1	1	1	1	1	1	1	1	1	1	1	1	1	1	1	1	1	1	965 605 510	5/05 =>	Kabel mit Stecker		Cable with plug	Câble avec prise	Cable con enchufe

PC-6412 S, PC-6414 S, PC-7312 S, PC-7314 S,  
PC-8114, PC-8116, PC-6412 S (UK), PC-7314 S (UK),  
PC-8114 (UK), PC-8116 (UK), PC-6430 (USA), PC-6435  
(USA), PC-7330 (USA), PC-7330 C (USA), PC-7335 (USA),  
PC-7335 C (USA), PC-8135 (USA), PC-8140 (USA)

6

Zylinder, Kurbeltrieb, Kupplung  
Cylinder, crankshaft, clutch  
Cylindre, vilebrequin, embrayage  
Cilindro, cigüeñal, embrague

**DOLMAR**  
A member of the *Makita* Group

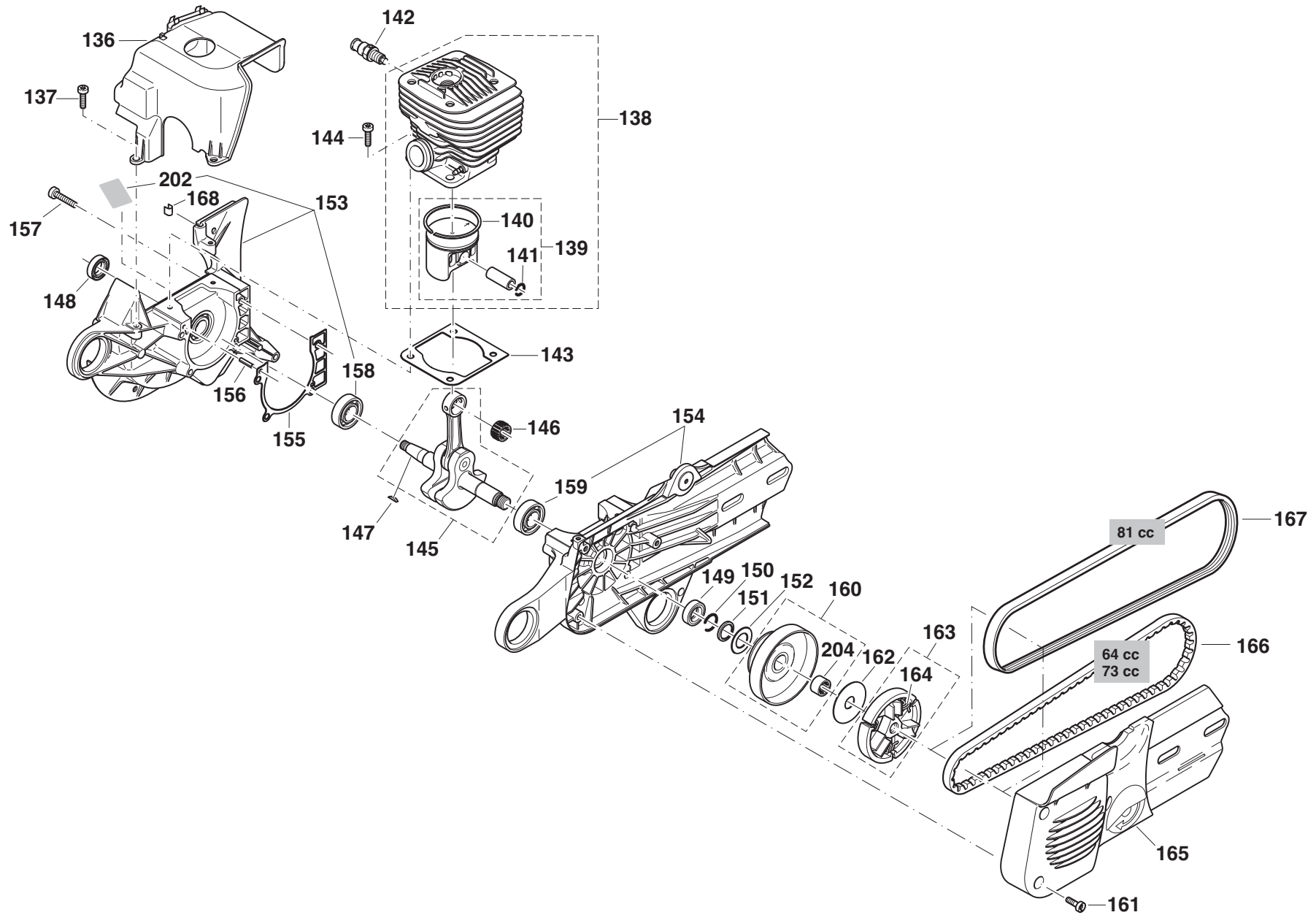



PC-6412 S, PC-6414 S, PC-7312 S, PC-7314 S,  
 PC-8114, PC-8116, PC-6412 S (UK), PC-7314 S (UK),  
 PC-8114 (UK), PC-8116 (UK), PC-6430 (USA), PC-6435  
 (USA), PC-7330 (USA), PC-7330 C (USA), PC-7335 (USA),  
 PC-7335 C (USA), PC-8135 (USA), PC-8140 (USA)

6

Zylinder, Kurbeltrieb, Kupplung  
 Cylinder, crankshaft, clutch  
 Cylindre, vilebrequin, embrayage  
 Cilíndro, cigüeñal, embrague

**DOLMAR**  
 A member of the *Makita* Group

Seite / Page	Pos.	PC-6412 S	PC-6414 S	PC-7312 S	PC-7314 S	PC-8114	PC-8116	PC-6412 S (UK)	PC-7314 S (UK)	PC-8114 (UK)	PC-8116 (UK)	PC-6430 (USA)	PC-6435 (USA)	PC-7330 (USA)	PC-7330 C (USA)	PC-7335 (USA)	PC-7335 C (USA)	PC-8135 (USA)	PC-8140 (USA)	Teil-Nr. Part No. No. de pièce No. de pieza	Hinweise Notes Renseign. Nota	Bezeichnung	Spezifikation Specification	Description	Désignation	Denominación
6	136	1	1	1	1	1	1	1	1	1	1	1	1	1	1	1	1	1	1	394 131 042		Kühlfluffhaube, schwarz		Hood	Capot	Cubierta
6	137	3	3	3	3	3	3	3	3	3	3	3	3	3	3	3	3	3	3	908 005 165		Schraube	M5x16	Screw	Vis	Tornillo
6	138	1	1					1				1	1							325 130 034		Zylinder / Kolben, kpl.	ø 47 Deco	Cylinder / piston, cpl.	Cylindre et piston, cpl.	Cilindro con pistón, cpl.
6	138			1	1				1					1	1	1	1			394 130 015		Zylinder / Kolben, kpl.	ø 50 Deco	Cylinder / piston, cpl.	Cylindre et piston, cpl.	Cilindro con pistón, cpl.
6	138					1	1			1	1							1	1	326 130 050		Zylinder / Kolben, kpl.	ø 52 Deco	Cylinder / piston, cpl.	Cylindre et piston, cpl.	Cilindro con pistón, cpl.
6	139	1	1					1				1	1							325 132 033		Kolben A kpl.	ø 47	Piston cpl.	Piston cpl.	Pistón cpl.
6	139		1	1					1					1	1	1	1			394 132 111		Kolben AB kpl.	ø 50	Piston cpl.	Piston cpl.	Pistón cpl.
6	139					1	1			1	1							1	1	038 132 001		Kolben AB kpl.	ø 52	Piston cpl.	Piston cpl.	Pistón cpl.
6	140	1	1					1				1	1							325 132 050		Kolbenring	ø 47	Piston ring	Segment de piston	Segmento de pistón
6	140			1	1				1					1	1	1	1			394 132 020		Kolbenring	ø 50	Piston ring	Segment de piston	Segmento de pistón
6	140					1	1			1	1							1	1	038 132 020		Kolbenring	ø 52	Piston ring	Segment de piston	Segmento de pistón
6	141	2	2	2	2	2	2	2	2	2	2	2	2	2	2	2	2	2	2	119 132 060		Sprengring	C12X1	Spring ring	Anneau-ressort	Anillo elástico
6	142	1	1	1	1	1	1	1	1	1	1	1	1	1	1	1	1	1	1	001 131 150		Dekompressionsventil		Valve	Soupape	Válvula
6	143	1	1	1	1	1	1	1	1	1	1	1	1	1	1	1	1	1	1	965 531 160		Zylinderfußdichtung, Metall		Gasket, metal	Joint, métal	Junta, metal
6	143	1	1	1	1			1	1			1	1	1	1	1	1			965 531 121		Zylinderfußdichtung, Papier		Gasket, paper	Joint, papier	Junta, papel
6	144	4	4	4	4	4	4	4	4	4	4	4	4	4	4	4	4	4	4	908 005 205		Innenstern-Schraube	M5x20	Screw	Vis	Tornillo
6	145	1	1	1	1			1	1			1	1	1	1	1	1			394 120 010		Kurbelwelle kpl.		Crankshaft cpl.	Vilebrequin cpl.	Cigüeñal cpl.
6	145					1	1			1	1							1	1	326 120 101		Kurbelwelle kpl.		Crankshaft cpl.	Vilebrequin cpl.	Cigüeñal cpl.
6	146	1	1	1	1	1	1	1	1	1	1	1	1	1	1	1	1	1	1	962 210 015		Nadelkäfig		Needle cage	Cage à aiguilles	Jaula de agujas
6	147	1	1	1	1	1	1	1	1	1	1	1	1	1	1	1	1	1	1	939 630 370		Scheibenfeder		Key	Clavette	Chaveta
6	148	1	1	1	1	1	1	1	1	1	1	1	1	1	1	1	1	1	1	962 900 052		Radialdichtring	ø15/24x7	Radial ring	Joint radial	Junta radial
6	149	1	1	1	1	1	1	1	1	1	1	1	1	1	1	1	1	1	1	962 900 052		Radialdichtring	ø15/24x7	Radial ring	Joint radial	Junta radial
6	150	1	1	1	1	1	1	1	1	1	1	1	1	1	1	1	1	1	1	930 916 160		Sprengring		Spring ring	Anneau-ressort	Anillo elástico
6	151	1	1	1	1	1	1	1	1	1	1	1	1	1	1	1	1	1	1	394 245 010		Anschlagring, gehärtet, verzinkt		Stop ring	Bague de butée	Anillo de deten.
6	152	1	1	1	1	1	1	1	1	1	1	1	1	1	1	1	1	1	1	394 182 020		Führungsscheibe		Guide disc	Disque de guidage	Disco de guía
6	153	1	1	1	1	1	1	1	1	1	1	1	1	1	1	1	1	1	1	326 111 731		Kurbelgehäuse kpl. MS, schwarz	incl. page 3: pos. 76,205,213	Crankc., mag. side	Carter-coté, magn.	Cárter cig., lado mag.
6	154	1	1	1	1	1	1	1	1	1	1	1	1	1	1	1	1	1	1	326 111 740		Kurbelgehäuse kpl. KS, schwarz		Crankc., clutch side	Carter-coté, embr.	Cárter cig., lado embr.
6	155	1	1	1	1	1	1	1	1	1	1	1	1	1	1	1	1	1	1	965 531 111		Kurbelgehäusedichtung		Gasket	Joint	Junta
6	156	2	2	2	2	2	2	2	2	2	2	2	2	2	2	2	2	2	2	936 430 160		Spiralspannstift	3X16	Clamping pin	Goupille	Pasador
6	157	5	5	5	5	5	5	5	5	5	5	5	5	5	5	5	5	5	5	908 005 305		Innenstern-Schraube	M5x30	Screw	Vis	Tornillo
6	158	1	1	1	1	1	1	1	1	1	1	1	1	1	1	1	1	1	1	960 102 159		Kugellager (einkleben)	6202	Ball bearing (use glue)	Roulement à billes (à collar)	Rodam. de bolas (a colar)
6	159	1	1	1	1	1	1	1	1	1	1	1	1	1	1	1	1	1	1	960 102 159		Kugellager (einkleben)	6202	Ball bearing (use glue)	Roulement à billes (à collar)	Rodam. de bolas (a colar)
6	160	1	1	1	1			1	1			1	1	1	1	1				394 223 023		Kupplungstrommel kpl.		Clutch drum assy.	Tambour cpl.	Tambor cpl.
6	160					1				1								1		326 223 030		Kupplungstrommel kpl.	ø350mm-80m	Clutch drum assy.	Tambour cpl.	Tambor cpl.
6	160							1											1	326 223 021		Kupplungstrommel kpl.	ø400mm-80m	Clutch drum assy.	Tambour cpl.	Tambor cpl.

PC-6412 S, PC-6414 S, PC-7312 S, PC-7314 S,  
PC-8114, PC-8116, PC-6412 S (UK), PC-7314 S (UK),  
PC-8114 (UK), PC-8116 (UK), PC-6430 (USA), PC-6435  
(USA), PC-7330 (USA), PC-7330 C (USA), PC-7335 (USA),  
PC-7335 C (USA), PC-8135 (USA), PC-8140 (USA)

6

Zylinder, Kurbeltrieb, Kupplung  
Cylinder, crankshaft, clutch  
Cylindre, vilebrequin, embrayage  
Cilindro, cigüeñal, embrague

**DOLMAR**  
A member of the *Makita* Group

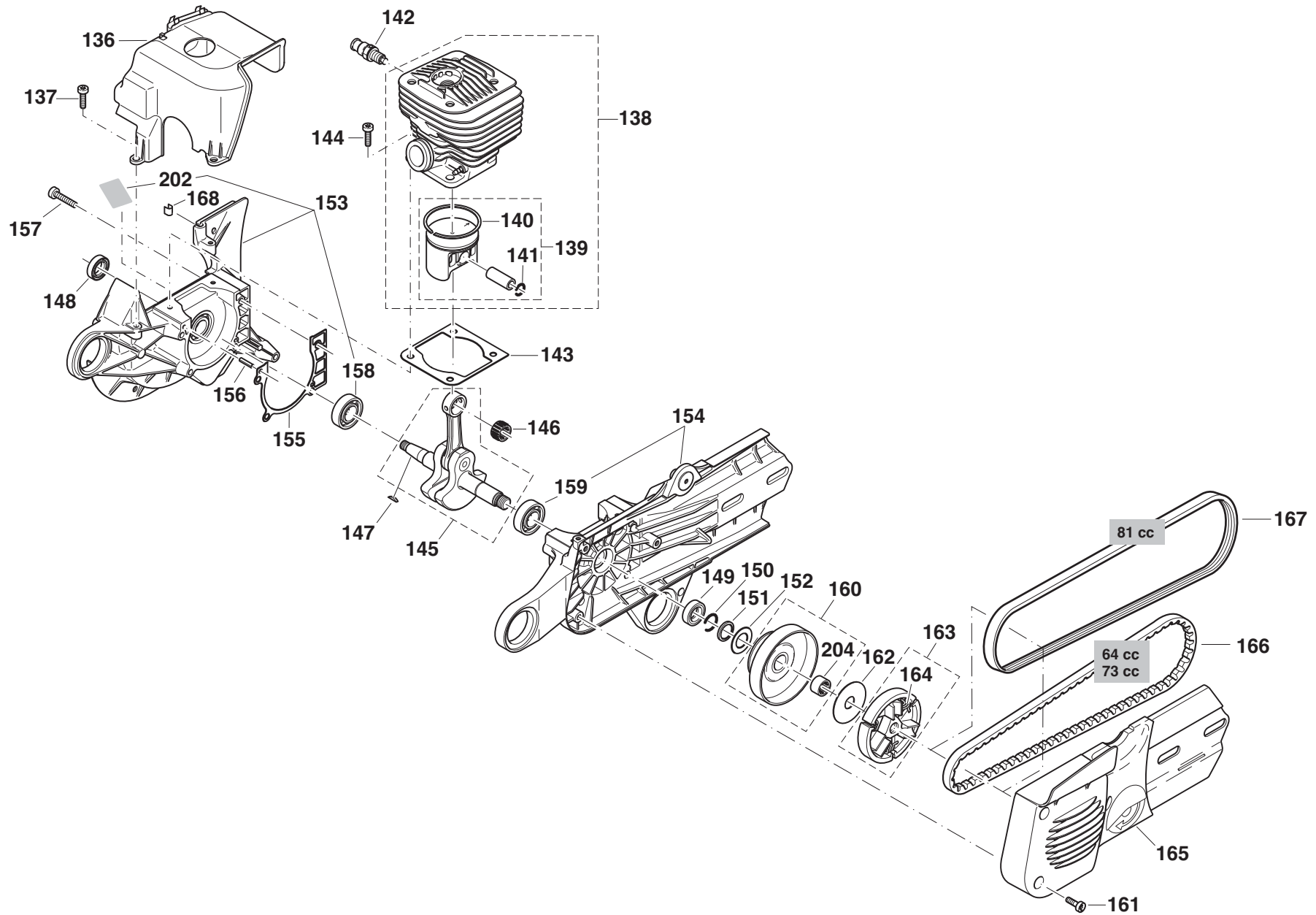

PC-6412 S, PC-6414 S, PC-7312 S, PC-7314 S,  
 PC-8114, PC-8116, PC-6412 S (UK), PC-7314 S (UK),  
 PC-8114 (UK), PC-8116 (UK), PC-6430 (USA), PC-6435  
 (USA), PC-7330 (USA), PC-7330 C (USA), PC-7335 (USA),  
 PC-7335 C (USA), PC-8135 (USA), PC-8140 (USA)

**6**

Zylinder, Kurbeltrieb, Kupplung  
 Cylinder, crankshaft, clutch  
 Cylindre, vilebrequin, embrayage  
 Cilíndro, cigüeñal, embrague



Seite / Page	Pos.	PC-6412 S	PC-6414 S	PC-7312 S	PC-7314 S	PC-8114	PC-8116	PC-6412 S (UK)	PC-7314 S (UK)	PC-8114 (UK)	PC-8116 (UK)	PC-6430 (USA)	PC-6435 (USA)	PC-7330 (USA)	PC-7330 C (USA)	PC-7335 (USA)	PC-7335 C (USA)	PC-8135 (USA)	PC-8140 (USA)	Teil-Nr. Part No. No. de pièce No. de pieza	Hinweise Notes Renseign. Nota	Bezeichnung	Spezifikation Specification	Description	Désignation	Denominación	
6	161	3	3	3	3	3	3	3	3	3	3	3	3	3	3	3	3	3	3	3	908 605 145		Innenstern-Schlitz-Schraube	M5x14	Screw	Vis	Tornillo
6	162	1	1	1	1	1	1	1	1	1	1	1	1	1	1	1	1	1	1	1	001 182 042		Führungsscheibe		Disc	Disque	Disco
6	163	1	1	1	1	1	1	1	1	1	1	1	1	1	1	1	1	1	1	1	010 180 022		Kupplung kpl.		Clutch assy.	Embrayage cpl.	Embrague cpl.
6	164	3	3	3	3	3	3	3	3	3	3	3	3	3	3	3	3	3	3	3	024 184 021		Zugfeder		Spring	Ressort	Resorte
6	165	1	1	1	1	1	1		1	1	1	1	1	1	1	1	1	1	1		394 213 070		Abdeckung mit Schlitzen, rot		Cover	Couvercle	Cubierta
6	165							1													394 213 080	U.K.	Abdeckung ohne Schlitze, rot		Cover -do not use on 73ccm machines	Couvercle	Cubierta
6	166	1	1	1	1			1	1			1	1	1	1	1	1				965 300 470		Keilriemen		V-belt	Courroie trapez	Correa estrecho
6	167					1				1									1		965 300 490		Keilrippenriemen	ø350mm-80m	V-belt	Courroie trapez	Correa estrecho
6	167						1				1									1	965 300 480		Keilrippenriemen	ø400mm-80m	V-belt	Courroie trapez	Correa estrecho
6	168	1	1	1	1	1	1	1	1	1	1	1	1	1	1	1	1	1	1	1	965 402 870		Fixiergummi	set=35 pcs.	Rubber plate	Plaque de caoutch.	Plancha de caucho
6	202	1	1	1	1			1	1			1	1	1							980 600 130	=> 4/05	Isolationsfolie		Insulating sheet	Feuille isolante	Hoja aislante
6	204	1	1	1	1	1	1	1	1	1	1	1	1	1	1	1	1	1	1	1	962 300 017		Nadelhülse		Needle bush	Roulement à aiguilles	Jaula de agujas

PC-6412 S, PC-6414 S, PC-7312 S, PC-7314 S,  
 PC-8114, PC-8116, PC-6412 S (UK), PC-7314 S (UK),  
 PC-8114 (UK), PC-8116 (UK), PC-6430 (USA), PC-6435  
 (USA), PC-7330 (USA), PC-7330 C (USA), PC-7335 (USA),  
 PC-7335 C (USA), PC-8135 (USA), PC-8140 (USA)

**7**

Schneidvorsatz, Schutzhaube  
 Cutting device, protection hood  
 Dispositif de coupe, capot de protection  
 Dispositivo tronzadora, cubierta protectora

**DOLMAR**  
 A member of the *Makita* Group

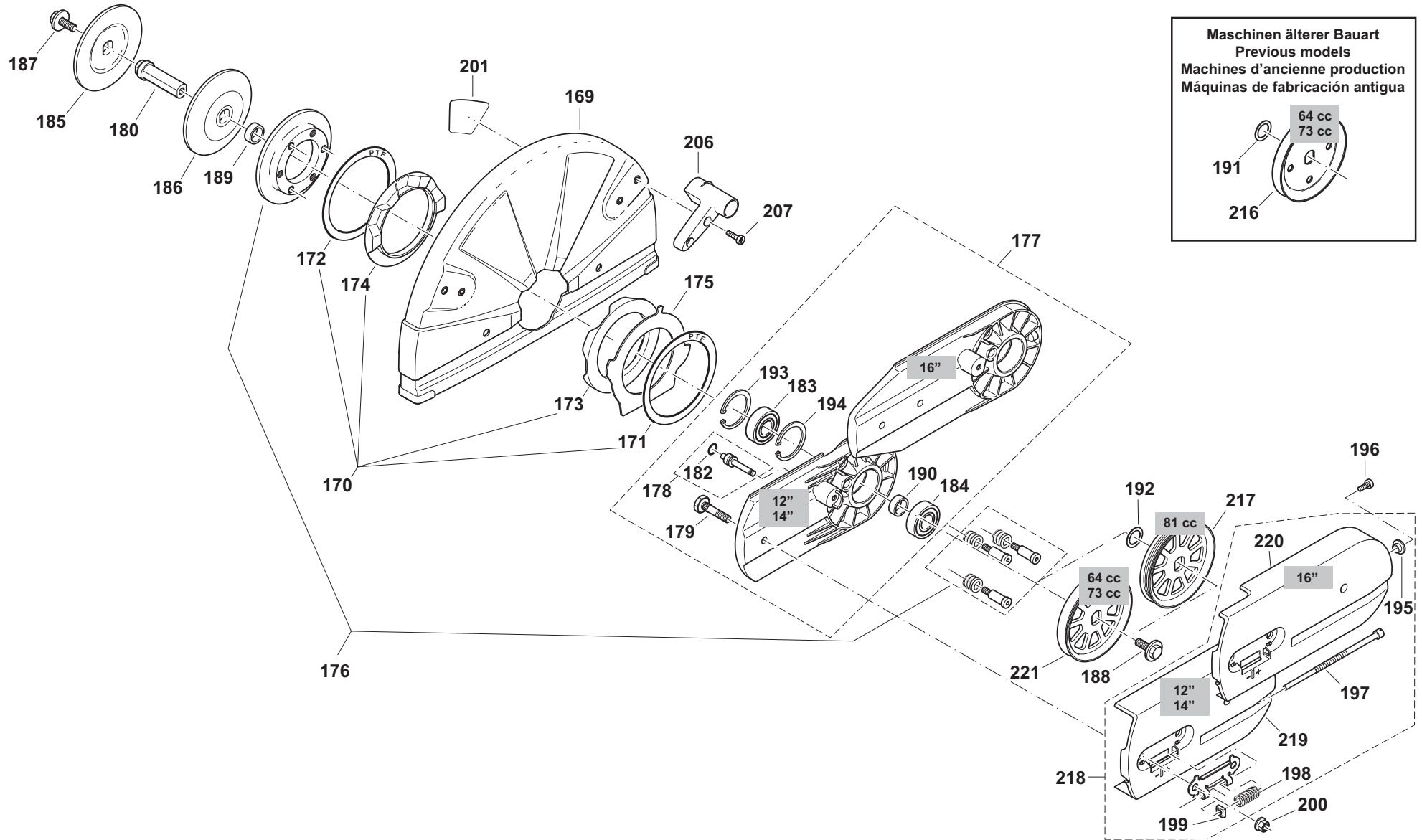

Maschinen älterer Bauart  
 Previous models  
 Machines d'ancienne production  
 Máquinas de fabricación antigua



PC-6412 S, PC-6414 S, PC-7312 S, PC-7314 S,  
 PC-8114, PC-8116, PC-6412 S (UK), PC-7314 S (UK),  
 PC-8114 (UK), PC-8116 (UK), PC-6430 (USA), PC-6435  
 (USA), PC-7330 (USA), PC-7330 C (USA), PC-7335 (USA),  
 PC-7335 C (USA), PC-8135 (USA), PC-8140 (USA)

**7**

Schneidvorsatz, Schutzhaube  
 Cutting device, protection hood  
 Dispositif de coupe, capot de protection  
 Dispositivo tronzadora, cubierta protectora

**DOLMAR**  
 A member of the *Makita* Group

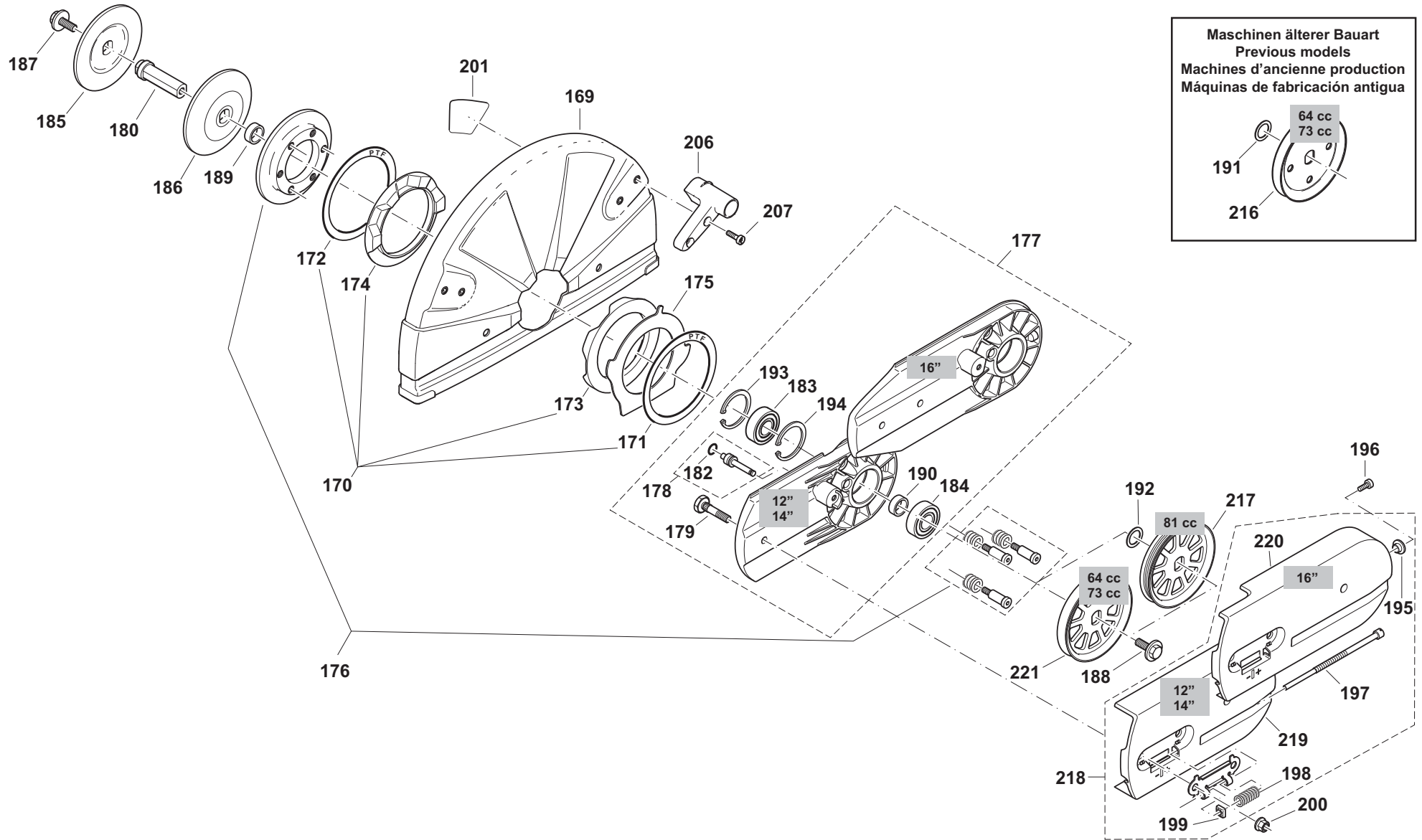

Maschinen älterer Bauart  
 Previous models  
 Machines d'ancienne production  
 Máquinas de fabricación antigua

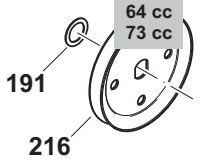

PC-6412 S, PC-6414 S, PC-7312 S, PC-7314 S,  
 PC-8114, PC-8116, PC-6412 S (UK), PC-7314 S (UK),  
 PC-8114 (UK), PC-8116 (UK), PC-6430 (USA), PC-6435  
 (USA), PC-7330 (USA), PC-7330 C (USA), PC-7335 (USA),  
 PC-7335 C (USA), PC-8135 (USA), PC-8140 (USA)

7

Schneidvorsatz, Schutzhaube  
 Cutting device, protection hood  
 Dispositif de coupe, capot de protection  
 Dispositivo tronzadora, cubierta protectora

**DOLMAR**  
 A member of the **Makita** Group

Seite / Page	Pos.	PC-6412 S	PC-6414 S	PC-7312 S	PC-7314 S	PC-8114	PC-8116	PC-6412 S (UK)	PC-7314 S (UK)	PC-8114 (UK)	PC-8116 (UK)	PC-6430 (USA)	PC-6435 (USA)	PC-7330 (USA)	PC-7330 C (USA)	PC-7335 (USA)	PC-7335 C (USA)	PC-8135 (USA)	PC-8140 (USA)	Teil-Nr. Part No. No. de pièce No. de pieza	Hinweise Notes Renseign. Nota	Bezeichnung	Spezifikation Specification	Description	Désignation	Denominación
7	201	1	1	1				1				1		1	1					980 114 972		Sicherheitsaufkleber	ø300/20,0mm; ø12"/.787"	Safety label	Plaque	Calcomania
7	201		1	1	1	1			1	1			1		1	1	1			980 114 975		Sicherheitsaufkleber	ø350/25,4mm; ø14"/1"	Safety label	Plaque	Calcomania
7	201		1	1					1				1		1					980 114 974		Sicherheitsaufkleber	ø350/20,0mm; ø14"/.787"	Safety label	Plaque	Calcomania
7	201						1				1								1	980 115 226		Sicherheitsaufkleber	ø400/20,0mmø; 16"/.787"	Safety label	Plaque	Calcomania
7	206	1	1	1	1	1	1	1	1	1	1	1	1	1	1	1	1	1	1	326 341 300		Griff für Schutzhaube		Grip	Poignée	Asa
7	207	2	2	2	2	2	2	2	2	2	2	2	2	2	2	2	2	2	2	908 605 165		Innenstern-Schlitz-Schraube	M5x16	Screw	Vis	Tornillo
7	216	1	1	1	1			1	1			1	1	1						394 221 010		Keilriemenscheibe		Belt pulley	Poulie	Polea
7	217					1	1			1	1								1	326 221 010		Keilrippenscheibe		Belt pulley	Poulie	Polea
7	218	1	1	1	1	1		1	1	1		1	1	1	1	1	1			394 211 180		Abdeckung Schneidvors. kpl., rot		Cover cpl.	Couvercle cpl.	Cubierta cpl.
7	218						1				1								1	326 211 140		Abdeckung Schneidvors. kpl., rot		Cover cpl.	Couvercle cpl.	Cubierta cpl.
7	219	1	1	1	1	1		1	1	1		1	1	1	1	1	1			394 211 025		Abdeckung Schneidvors., rot		Cover	Couvercle	Cubierta
7	220						1				1								1	326 211 010		Abdeckung Schneidvors., rot		Cover	Couvercle	Cubierta
7	221	1	1	1	1			1	1			1	1	1	1	1				394 221 050		Keilriemenscheibe		Belt pulley	Poulie	Polea

PC-6412 S, PC-6414 S, PC-7312 S, PC-7314 S,  
PC-8114, PC-8116, PC-6412 S (UK), PC-7314 S (UK),  
PC-8114 (UK), PC-8116 (UK), PC-6430 (USA), PC-6435  
(USA), PC-7330 (USA), PC-7330 C (USA), PC-7335 (USA),  
PC-7335 C (USA), PC-8135 (USA), PC-8140 (USA)

**8**

Trennscheiben, Werkzeug  
Blades, tools  
Disques, outils  
Discos para dividir, herramientas

**DOLMAR**  
A member of the *makita* Group

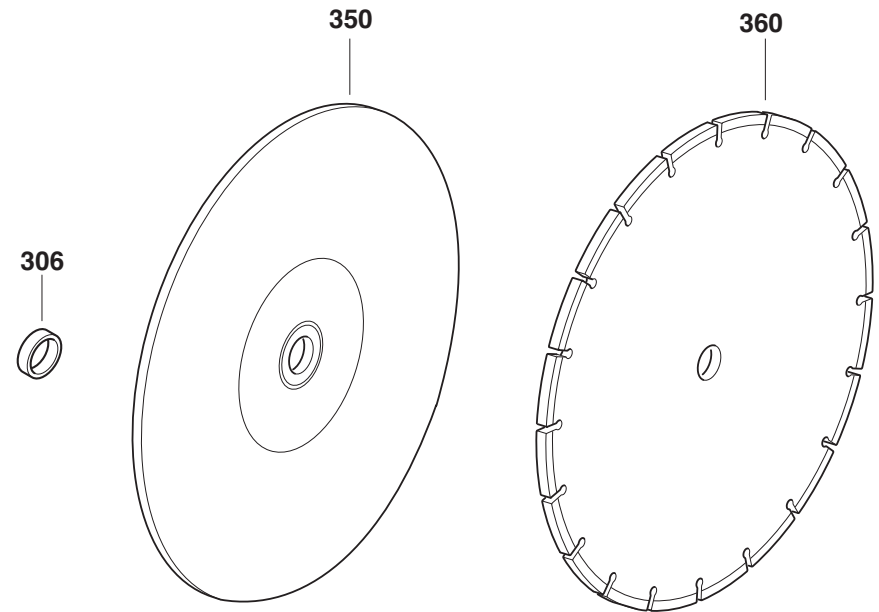
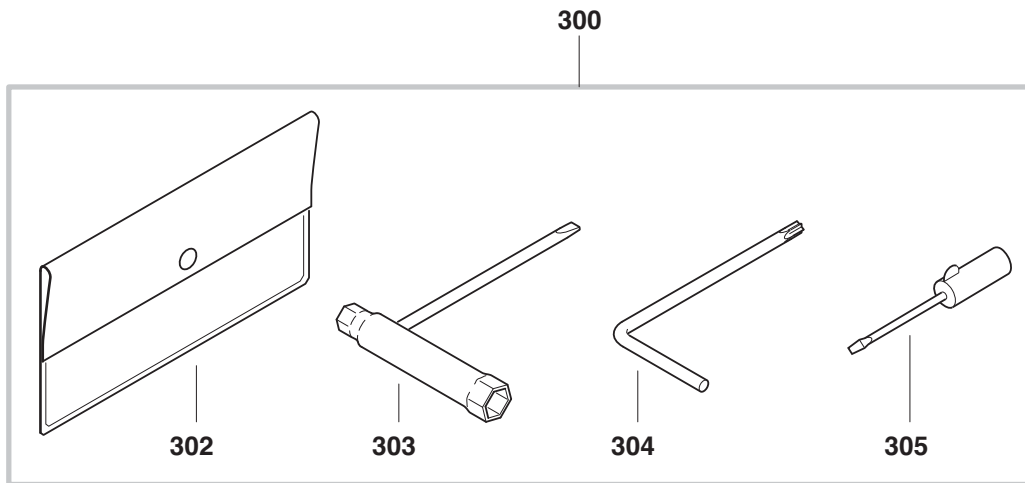



PC-6412 S, PC-6414 S, PC-7312 S, PC-7314 S,  
 PC-8114, PC-8116, PC-6412 S (UK), PC-7314 S (UK),  
 PC-8114 (UK), PC-8116 (UK), PC-6430 (USA), PC-6435  
 (USA), PC-7330 (USA), PC-7330 C (USA), PC-7335 (USA),  
 PC-7335 C (USA), PC-8135 (USA), PC-8140 (USA)

8

Trennscheiben, Werkzeug  
 Blades, tools  
 Disques, outils  
 Discos para dividir, herramientas

**DOLMAR**  
 A member of the **Makita** Group

Seite / Page	Pos.	PC-6412 S	PC-6414 S	PC-7312 S	PC-7314 S	PC-8114	PC-8116	PC-6412 S (UK)	PC-7314 S (UK)	PC-8114 (UK)	PC-8116 (UK)	PC-6430 (USA)	PC-6435 (USA)	PC-7330 (USA)	PC-7330 C (USA)	PC-7335 (USA)	PC-7335 C (USA)	PC-8135 (USA)	PC-8140 (USA)	Teil-Nr. Part No. No. de pièce No. de pieza	Hinweise Notes Renseign. Nota	Bezeichnung	Spezifikation Specification	Description	Désignation	Denominación	
8	300	1	1	1	1	1	1	1	1	1	1	1	1	1	1	1	1	1	1	1	957 004 006		Werkzeug kpl.		Tools cpl.	Outils cpl.	Herramientas cpl.
8	302	1	1	1	1	1	1	1	1	1	1	1	1	1	1	1	1	1	1	1	950 004 002		Werkzeugtasche		Plastik bag	Pochette en plastique	Cartera herramientas
8	303	1	1	1	1	1	1	1	1	1	1	1	1	1	1	1	1	1	1	1	941 719 140		Kombischlüssel	SW 13/19	Universal wrench	Clé combinée	Llave de bujia
8	304	1	1	1	1	1	1	1	1	1	1	1	1	1	1	1	1	1	1	1	940 827 000		Winkelschraubendreher	T27	Angled screw driver	Clé angle	Llave angular
8	305	1	1	1	1	1	1	1	1	1	1	1	1	1	1	1	1	1	1	1	944 340 001		Schraubendreher		Screw driver	Tournevis	Destornillador
8	306	1	1				1					1	1	1							394 228 121	Acc.	Adapting	ø 20/25,4 mm	Adapter	Adaptateur	Adaptor
8	350	1	1				1					1	1	1							966 121 150		Trennsch. Harz, Stahl	300/20mm; 12"	Abras. blade, steel	Disque synth. Acier	Disco sint. Acero
8	350	1	1				1					1	1	1							966 121 120		Trennsch. Harz, Stein	300/20mm; 12"	Abras. blade, stone	Disque synth. Béton	Disco sint. Pedra
8	350	1	1	1	1			1	1			1			1	1	1				966 141 120		Trennsch. Harz, Stein	350/20mm; 14"	Abras. blade, stone	Disque synth. Béton	Disco sint. Pedra
8	350	1	1	1				1	1			1			1	1	1				966 144 150		Trennsch. Harz, Stahl	350/25,4mm; 14"	Abras. blade, steel	Disque synth. Acier	Disco sint. Acero
8	350	1	1	1				1	1			1			1	1	1				966 141 150		Trennsch. Harz, Stahl	350/20mm; 14"	Abras. blade, steel	Disque synth. Acier	Disco sint. Acero
8	350	1	1	1				1	1			1			1	1	1				966 144 120		Trennsch. Harz, Stein	350/25,4mm; 14"	Abras. blade, stone	Disque synth. Béton	Disco sint. Pedra
8	350						1					1									966 161 050		Trennsch. Harz, Stahl	400/20mm; 16"	Abras. blade, steel	Disque synth. Acier	Disco sint. Acero
8	350						1					1									966 161 020		Trennsch. Harz, Stein	400/20mm; 16"	Abras. blade, stone	Disque synth. Béton	Disco sint. Pedra
8	360	1	1					1				1	1	1							966 221 021	Acc.	Diamant, Beton Standard	300/20mm; 12"	Diamond blade Concr. Stand.	Disque diamant, Béton Stand.	Disco diamant., Hormigón Stand.
8	360	1	1					1				1	1	1							966 321 020	Acc.	Diamant, Beton DiaDuran	300/20mm; 12"	Diamond blade Concr. DiaDuran	Disque diamant, Béton DiaDuran	Disco diamant., Hormigón DiaDuran
8	360	1	1					1				1	1	1							966 221 010	Acc.	Diamant, Asphalt Standard	300/20mm; 12"	Diamond blade Asphalt Stand.	Disque diamant, Asphalt Stand.	Disco diamant., Asfalto Stand.
8	360	1	1	1	1			1	1			1			1	1	1				966 341 020	Acc.	Diamant, Beton DiaDuran	350/20mm; 14"	Diamond blade Concr. DiaDuran	Disque diamant, Béton DiaDuran	Disco diamant., Hormigón DiaDuran
8	360	1	1	1	1			1	1			1			1	1	1				966 344 020	Acc.	Diamant, Beton DiaDuran	350/25,4mm; 14"	Diamond blade Concr. DiaDuran	Disque diamant, Béton DiaDuran	Disco diamant., Hormigón DiaDuran
8	360	1	1	1				1	1			1			1	1	1				966 241 021	Acc.	Diamant, Beton Standard	350/20mm; 14"	Diamond blade Concr. Stand.	Disque diamant, Béton Stand.	Disco diamant., Hormigón Stand.
8	360	1	1	1				1	1			1			1	1	1				966 244 021	Acc.	Diamant, Beton Standard	350/25,4mm; 14"	Diamond blade Concr. Stand.	Disque diamant, Béton Stand.	Disco diamant., Hormigón Stand.
8	360	1	1	1				1	1			1			1	1	1				966 344 010	Acc.	Diamant, Asphalt DiaDuran	350/25,4mm; 14"	Diamond blade Asph. DiaDuran	Disque diamant, Asph. DiaDuran	Disco diamant., Asfalto DiaDuran
8	360	1	1	1				1	1			1			1	1	1				966 341 010	Acc.	Diamant, Asphalt DiaDuran	350/20mm; 14"	Diamond blade Asph. DiaDuran	Disque diamant, Asph. DiaDuran	Disco diamant., Asfalto DiaDuran
8	360	1	1	1				1	1			1			1	1	1				966 241 010	Acc.	Diamant, Asphalt Standard	350/20mm; 14"	Diamond blade Asphalt Stand.	Disque diamant, Asphalt Stand.	Disco diamant., Asfalto Stand.
8	360	1	1	1				1	1			1			1	1	1				966 244 010	Acc.	Diamant, Asphalt Standard	350/25,4mm; 14"	Diamond blade Asphalt Stand.	Disque diamant, Asphalt Stand.	Disco diamant., Asfalto Stand.
8	360			1	1										1	1	1				966 544 060		Diamant, univ. Rescue Force	350/25,4mm; 14"	Diamant, univ. Rescue Force	Diamant, univ. Rescue Force	Diamant, univ. Rescue Force

PC-6412 S, PC-6414 S, PC-7312 S, PC-7314 S,  
PC-8114, PC-8116, PC-6412 S (UK), PC-7314 S (UK),  
PC-8114 (UK), PC-8116 (UK), PC-6430 (USA), PC-6435  
(USA), PC-7330 (USA), PC-7330 C (USA), PC-7335 (USA),  
PC-7335 C (USA), PC-8135 (USA), PC-8140 (USA)

9

Wasseranschluß, Druckwassertank • Nicht im Lieferumfang  
Water attachment, pressurised water tank • Not included in delivery  
Raccordement d'eau, réservoir d'eau sous pres. • Non incl. dans la livraison  
Acometida de agua, tanque de agua a pres. • No incluidos en entrega

**DOLMAR**  
A member of the *Traktia* Group

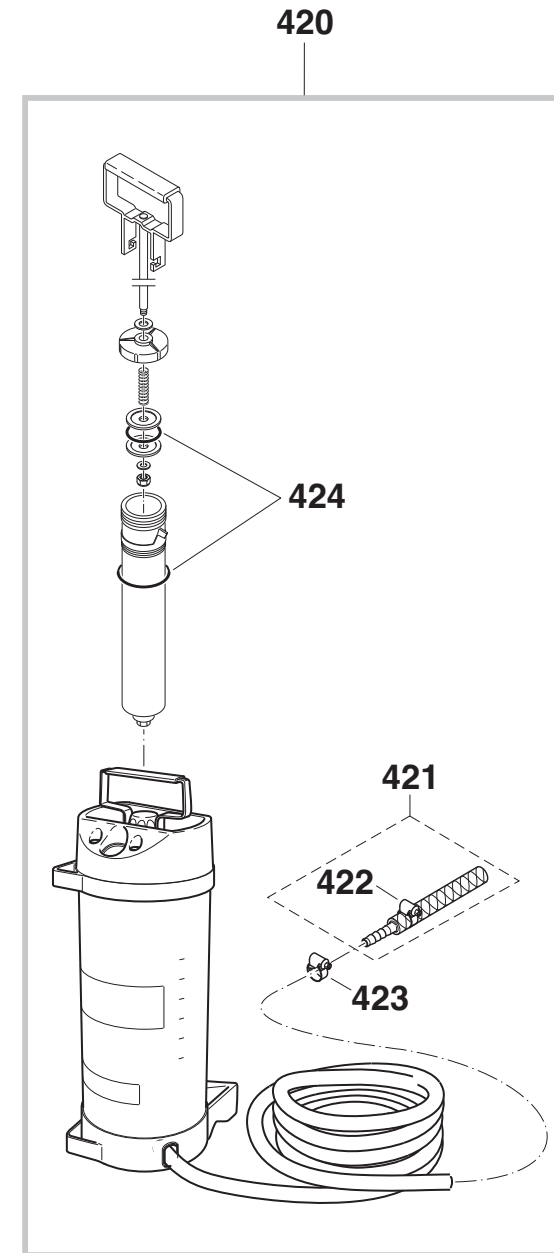
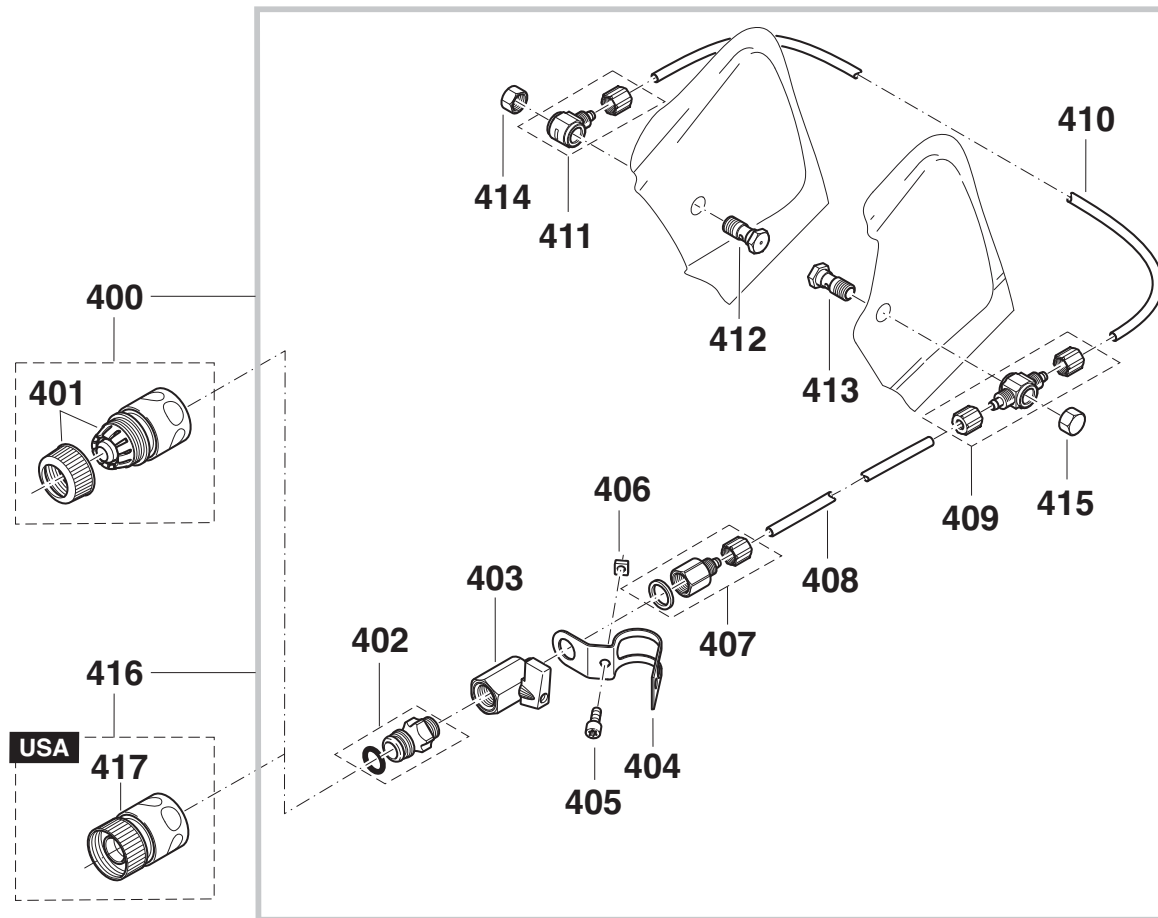

PC-6412 S, PC-6414 S, PC-7312 S, PC-7314 S,  
 PC-8114, PC-8116, PC-6412 S (UK), PC-7314 S (UK),  
 PC-8114 (UK), PC-8116 (UK), PC-6430 (USA), PC-6435  
 (USA), PC-7330 (USA), PC-7330 C (USA), PC-7335 (USA),  
 PC-7335 C (USA), PC-8135 (USA), PC-8140 (USA)

9

Wasseranschluß, Druckwassertank • Nicht im Lieferumfang  
 Water attachment, pressurised water tank • Not included in delivery  
 Raccordement d'eau, réservoir d'eau sous pres. • Non incl. dans la livraison  
 Acometida de agua, tanque de agua a pres. • No incluidos en entrega



Seite / Page	Pos.	PC-6412 S	PC-6414 S	PC-7312 S	PC-7314 S	PC-8114	PC-8116	PC-6412 S (UK)	PC-7314 S (UK)	PC-8114 (UK)	PC-8116 (UK)	PC-6430 (USA)	PC-6435 (USA)	PC-7330 (USA)	PC-7330 C (USA)	PC-7335 (USA)	PC-7335 C (USA)	PC-8135 (USA)	PC-8140 (USA)	Teil-Nr. Part No. No. de pièce No. de pieza	Hinweise Notes Renseign. Nota	Bezeichnung	Spezifikation Specification	Description	Désignation	Denominación
9	400	1	1	1	1	1	1	1	1	1	1									394 365 101		Druck-, Fallwasserarmatur		Water attachment kit	Jeu de raccordement d'eau	Acometida de agua
9	401	1	1	1	1	1	1	1	1	1	1									964 802 271		Schlauchkupplung	STOP	Coupling sleeve	Manchon d'accouplement	Acoplamiento p. tubos
9	402	1	1	1	1	1	1	1	1	1	1	1	1	1	1	1	1	1	1	964 802 280		Einschraubnippel		Hose connector	Raccord pour tuyau	Boquilla roscada
9	403	1	1	1	1	1	1	1	1	1	1	1	1	1	1	1	1	1	1	964 802 290		Kugelventil		Shut off cock	Robinet d'arrêt	Llave de paso
9	404	1	1	1	1	1	1	1	1	1	1	1	1	1	1	1	1	1	1	394 365 160		Schelle		Clamp	Bride de fixation	Abrazadera
9	405	1	1	1	1	1	1	1	1	1	1	1	1	1	1	1	1	1	1	908 006 105		Innenstern-Schraube	M6x10	Screw	Vis	Tornillo
9	406	1	1	1	1	1	1	1	1	1	1	1	1	1	1	1	1	1	1	921 906 004		4kt-Mutter	M6	Square nut	Écrou carré	Tuerca cuadr.
9	407	1	1	1	1	1	1	1	1	1	1	1	1	1	1	1	1	1	1	964 802 310		Schnellverschraubung		Connecting piece	Pièce de raccord	Pieza de unión
9	408	m	m	m	m	m	m	m	m	m	m	m	m	m	m	m	m	m	m	964 802 321		PU-Schlauch	405mm; 16"	Hose	Tuyau	Tubo
9	409	1	1	1	1	1	1	1	1	1	1	1	1	1	1	1	1	1	1	964 802 330		Schnellverschraubung T	T	Connecting piece T	Pièce de raccord	Pieza de unión
9	410	m	m					m				m		m	m					964 802 321		PU-Schlauch	180mm; 7"	Hose	Tuyau	Tubo
9	410		m		m	m		m	m	m				m	m	m				964 802 321		PU-Schlauch	210mm; 8 1/4"	Hose	Tuyau	Tubo
9	411	1	1	1	1	1	1	1	1	1	1	1	1	1	1	1	1	1	1	964 802 340		Schnellverschraubung L	L	Connecting piece L	Pièce de raccord	Pieza de unión
9	412	1	1	1	1	1	1	1	1	1	1	1	1	1	1	1	1	1	1	964 802 351		Hohlschraube (Düse)		Nozzle	Tuyère	Tobera
9	413	1	1	1	1	1	1	1	1	1	1	1	1	1	1	1	1	1	1	964 802 351		Hohlschraube (Düse)		Nozzle	Tuyère	Tobera
9	414	1	1	1	1	1	1	1	1	1	1	1	1	1	1	1	1	1	1	964 802 361		Hutmutter		Cap nut	Écrou borgne	Tuerca
9	415	1	1	1	1	1	1	1	1	1	1	1	1	1	1	1	1	1	1	964 802 361		Hutmutter		Cap nut	Écrou borgne	Tuerca
9	416											1	1	1	1	1	1	1	1	394 365 330	U.S.A.	Druck-, Fallwasserarmatur		Water attachment kit	Jeu de raccordement d'eau	Acometida de agua
9	417											1	1	1	1	1	1	1	1	964 802 400	U.S.A.	Schlauchkupplung	STOP 1 1/16"	Coupling sleeve	Manchon d'accouplement	Acoplamiento p. tubos
9	420	1	1	1	1	1	1	1	1	1	1	1	1	1	1	1	1	1	1	957 802 200		Druckwassertank	10 l	Pressurised water tank	Réservoir d'eau sous pres.	Tanque de agua a pres.
9	421	1	1	1	1	1	1	1	1	1	1	1	1	1	1	1	1	1	1	394 365 180		Schlauchadapter		Connecting reducer	Raccord réducteur	Reductor
9	422	1	1	1	1	1	1	1	1	1	1	1	1	1	1	1	1	1	1	964 802 250		Schlauchschelle	ø10-16 mm	Hose clip	Collier de serrage	Abrazadera
9	423	1	1	1	1	1	1	1	1	1	1	1	1	1	1	1	1	1	1	964 802 250		Schlauchschelle	ø10-16 mm	Hose clip	Collier de serrage	Abrazadera
9	424	1	1	1	1	1	1	1	1	1	1	1	1	1	1	1	1	1	1	957 963 200		Dichtungssatz		Gasket set	Jeu de joints	Juego juntas

PC-6412 S, PC-6414 S, PC-7312 S, PC-7314 S,  
PC-8114, PC-8116, PC-6412 S (UK), PC-7314 S (UK),  
PC-8114 (UK), PC-8116 (UK), PC-6430 (USA), PC-6435  
(USA), PC-7330 (USA), PC-7330 C (USA), PC-7335 (USA),  
PC-7335 C (USA), PC-8135 (USA), PC-8140 (USA)

10

Führungswagen • Nicht im Lieferumfang  
Guide trolley • Not included in delivery  
Chariot de guidage • Non incl. dans la livrais  
Carro de guía • No incluidos en entrega

**DOLMAR**  
A member of the *Traktia* Group

500

501

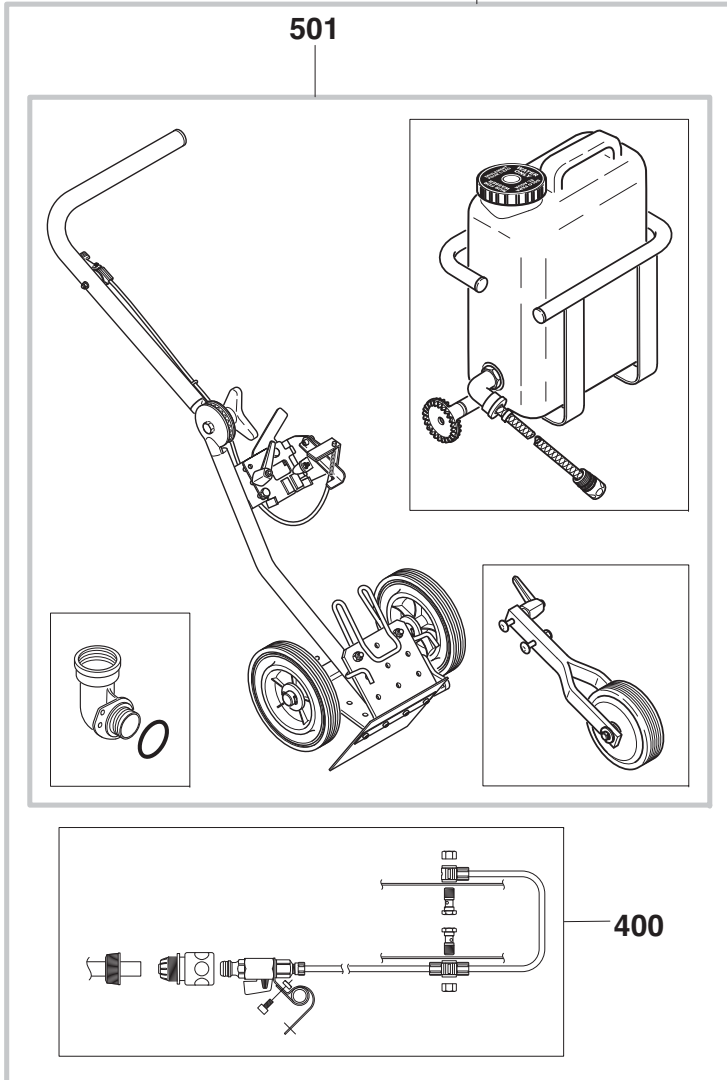

502

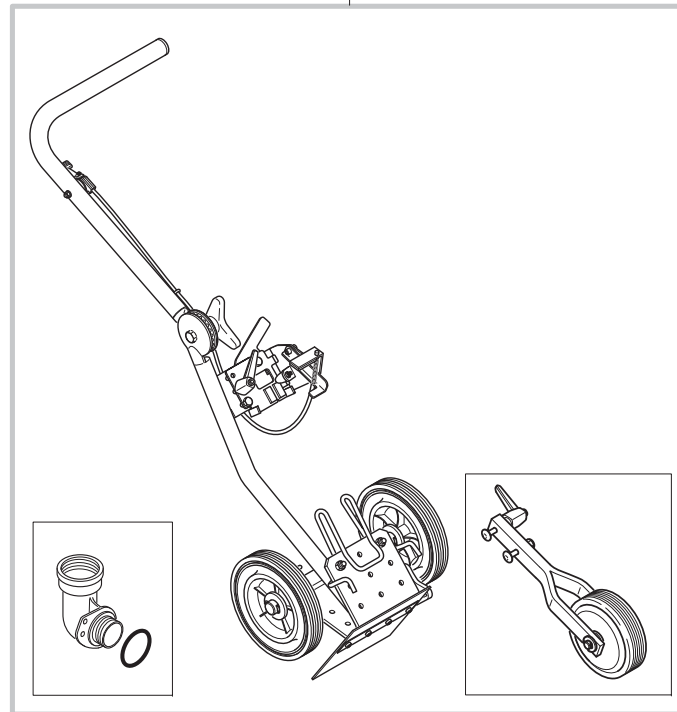

503

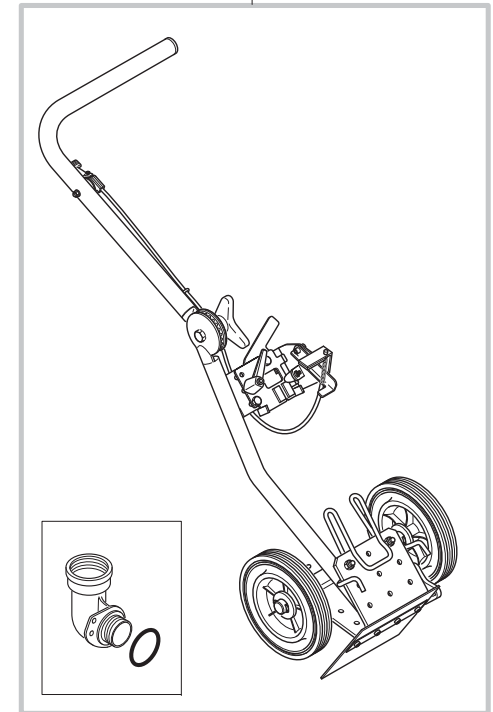

PC-6412 S, PC-6414 S, PC-7312 S, PC-7314 S,  
 PC-8114, PC-8116, PC-6412 S (UK), PC-7314 S (UK),  
 PC-8114 (UK), PC-8116 (UK), PC-6430 (USA), PC-6435  
 (USA), PC-7330 (USA), PC-7330 C (USA), PC-7335 (USA),  
 PC-7335 C (USA), PC-8135 (USA), PC-8140 (USA)

**10**

Führungswagen • Nicht im Lieferumfang  
 Guide trolley • Not included in delivery  
 Chariot de guidage • Non incl. dans la livrais  
 Carro de guía • No incluidos en entrega



Seite / Page	Pos.	PC-6412 S	PC-6414 S	PC-7312 S	PC-7314 S	PC-8114	PC-8116	PC-6412 S (UK)	PC-7314 S (UK)	PC-8114 (UK)	PC-8116 (UK)	PC-6430 (USA)	PC-6435 (USA)	PC-7330 (USA)	PC-7330 C (USA)	PC-7335 (USA)	PC-7335 C (USA)	PC-8135 (USA)	PC-8140 (USA)	Teil-Nr. Part No. No. de pièce No. de pieza	Hinweise Notes Renseign. Nota	Bezeichnung	Spezifikation Specification	Description	Désignation	Denominación
10	500	1	1	1	1	1	1	1	1	1	1	1	1	1	1	1	1	1	1	700 394 323		Führungswagen, schwarz	PT-2000 WS	Guide trolley cpl.	Chariot de guidage cpl.	Carro de guía cpl.
10	501	1	1	1	1	1	1	1	1	1	1	1	1	1	1	1	1	1	1	700 394 322		Führungswagen	PT-2000	Guide trolley cpl.	Chariot de guidage cpl.	Carro de guía cpl.
10	502	1	1	1	1	1	1	1	1	1	1	1	1	1	1	1	1	1	1	700 394 310		Führungswagen	PT-1900	Guide trolley	Chariot de guidage	Carro de guía
10	503	1	1	1	1	1	1	1	1	1	1	1	1	1	1	1	1	1	1	700 394 300		Führungswagen	PT-1800	Guide trolley	Chariot de guidage	Carro de guía

PC-6412 S, PC-6414 S, PC-7312 S, PC-7314 S,  
PC-8114, PC-8116, PC-6412 S (UK), PC-7314 S (UK),  
PC-8114 (UK), PC-8116 (UK), PC-6430 (USA), PC-6435  
(USA), PC-7330 (USA), PC-7330 C (USA), PC-7335 (USA),  
PC-7335 C (USA), PC-8135 (USA), PC-8140 (USA)

11

Führungswagen • Nicht im Lieferumfang  
Guide trolley • Not included in delivery  
Chariot de guidage • Non incl. dans la livrais  
Carro de guía • No incluidos en entrega

**DOLMAR**  
A member of the *Makita* Group

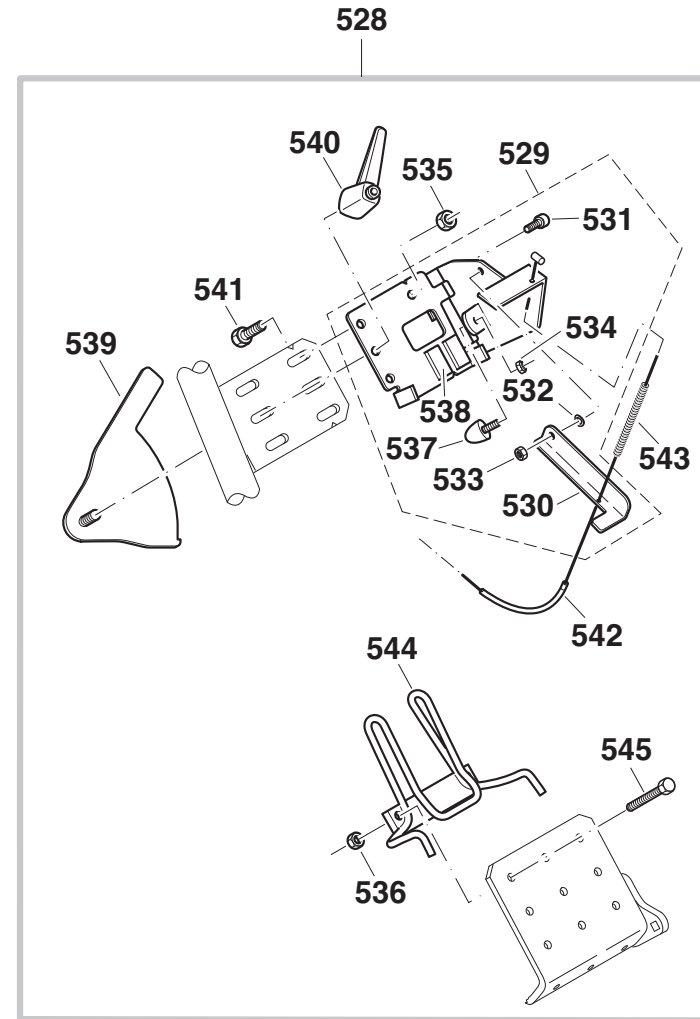
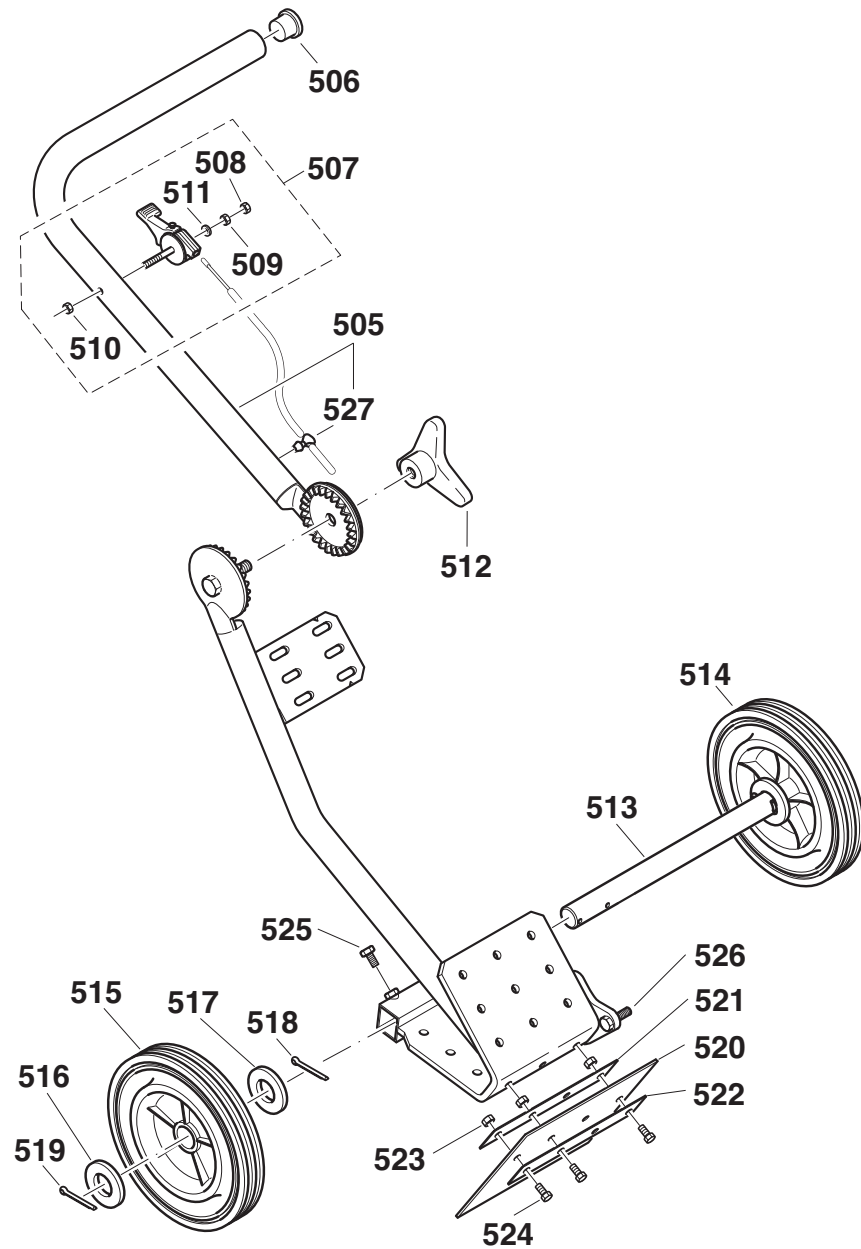



PC-6412 S, PC-6414 S, PC-7312 S, PC-7314 S,  
PC-8114, PC-8116, PC-6412 S (UK), PC-7314 S (UK),  
PC-8114 (UK), PC-8116 (UK), PC-6430 (USA), PC-6435  
(USA), PC-7330 (USA), PC-7330 C (USA), PC-7335 (USA),  
PC-7335 C (USA), PC-8135 (USA), PC-8140 (USA)

11

Führungswagen • Nicht im Lieferumfang  
Guide trolley • Not included in delivery  
Chariot de guidage • Non incl. dans la livrais  
Carro de guía • No incluidos en entrega

**DOLMAR**  
A member of the *Makita* Group

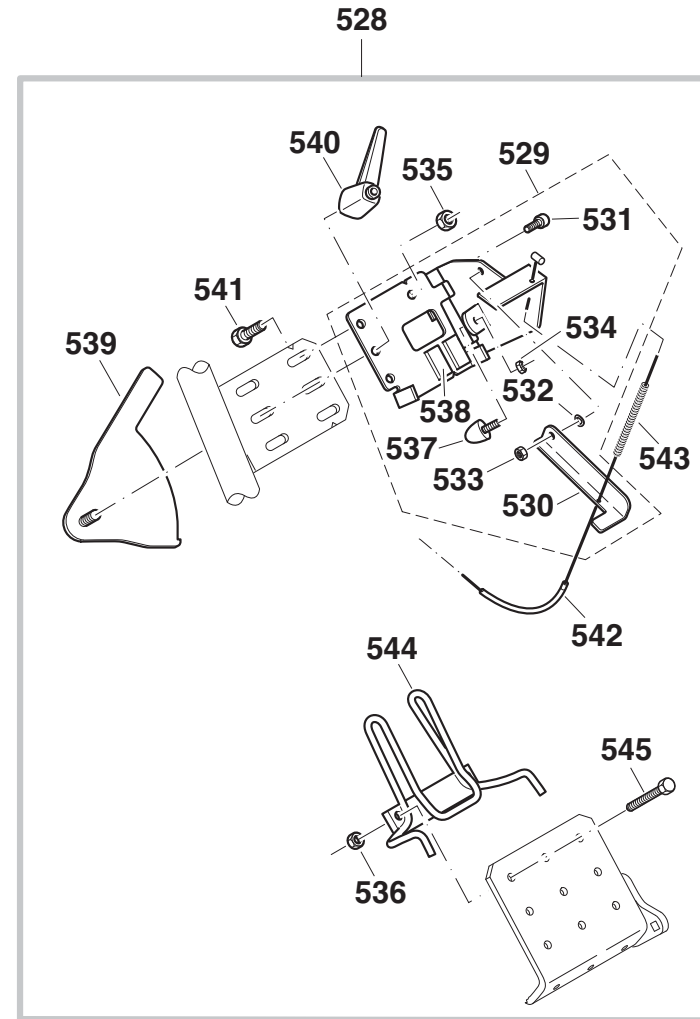
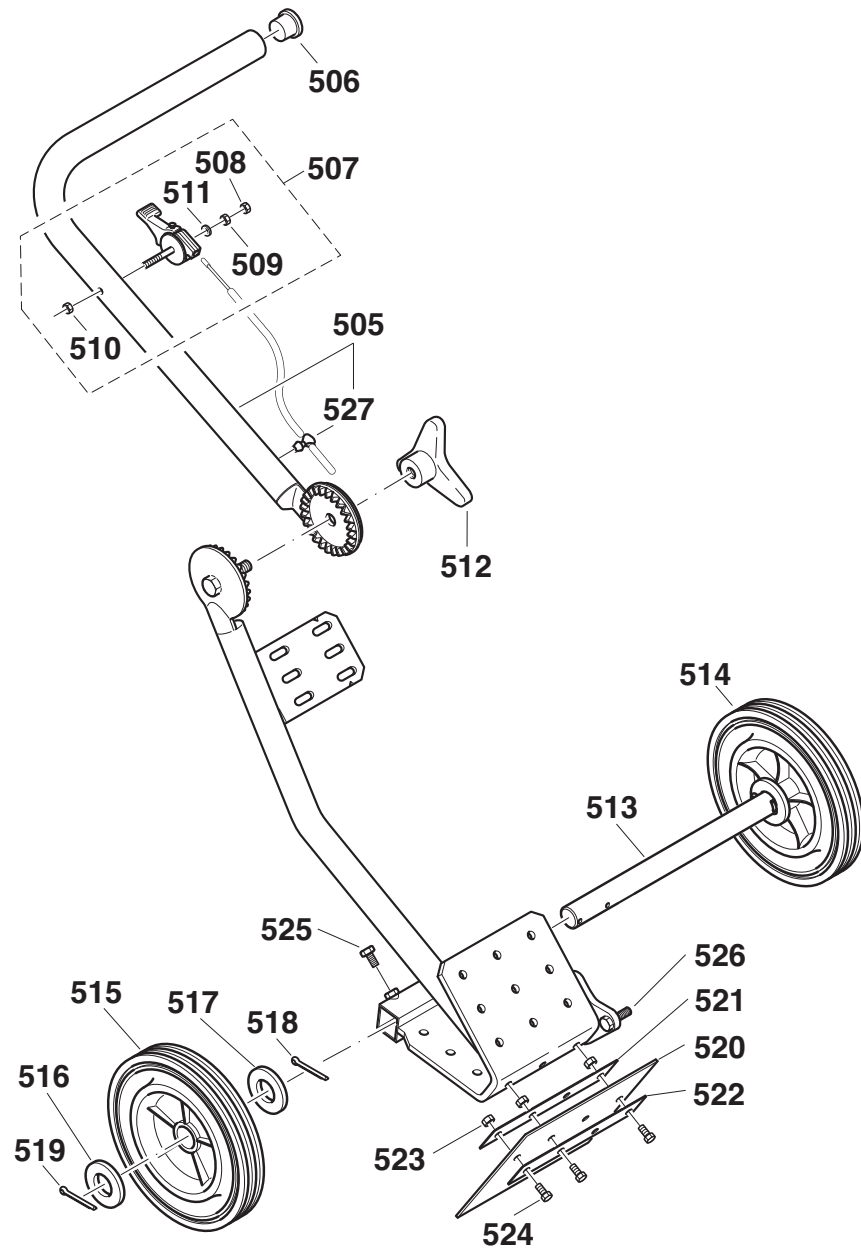



PC-6412 S, PC-6414 S, PC-7312 S, PC-7314 S,  
 PC-8114, PC-8116, PC-6412 S (UK), PC-7314 S (UK),  
 PC-8114 (UK), PC-8116 (UK), PC-6430 (USA), PC-6435  
 (USA), PC-7330 (USA), PC-7330 C (USA), PC-7335 (USA),  
 PC-7335 C (USA), PC-8135 (USA), PC-8140 (USA)

**11**

Führungswagen • Nicht im Lieferumfang  
 Guide trolley • Not included in delivery  
 Chariot de guidage • Non incl. dans la livrais  
 Carro de guía • No incluidos en entrega



Seite / Page	Pos.	PC-6412 S	PC-6414 S	PC-7312 S	PC-7314 S	PC-8114	PC-8116	PC-6412 S (UK)	PC-7314 S (UK)	PC-8114 (UK)	PC-8116 (UK)	PC-6430 (USA)	PC-6435 (USA)	PC-7330 (USA)	PC-7330 C (USA)	PC-7335 (USA)	PC-7335 C (USA)	PC-8135 (USA)	PC-8140 (USA)	Teil-Nr. Part No. No. de pièce No. de pieza	Hinweise Notes Renseign. Nota	Bezeichnung	Spezifikation Specification	Description	Désignation	Denominación
11	545	2	2	2	2	2	2	2	2	2	2	2	2	2	2	2	2	2	2	900 208 354		6kt-Schraube	M8X 35 DIN933	Hexagonal screw	Vis hexagonal	Tornillo hexagonal

PC-6412 S, PC-6414 S, PC-7312 S, PC-7314 S,  
 PC-8114, PC-8116, PC-6412 S (UK), PC-7314 S (UK),  
 PC-8114 (UK), PC-8116 (UK), PC-6430 (USA), PC-6435  
 (USA), PC-7330 (USA), PC-7330 C (USA), PC-7335 (USA),  
 PC-7335 C (USA), PC-8135 (USA), PC-8140 (USA)

12

Führungswagen • Nicht im Lieferumfang  
 Guide trolley • Not included in delivery  
 Chariot de guidage • Non incl. dans la livrais  
 Carro de guía • No incluidos en entrega

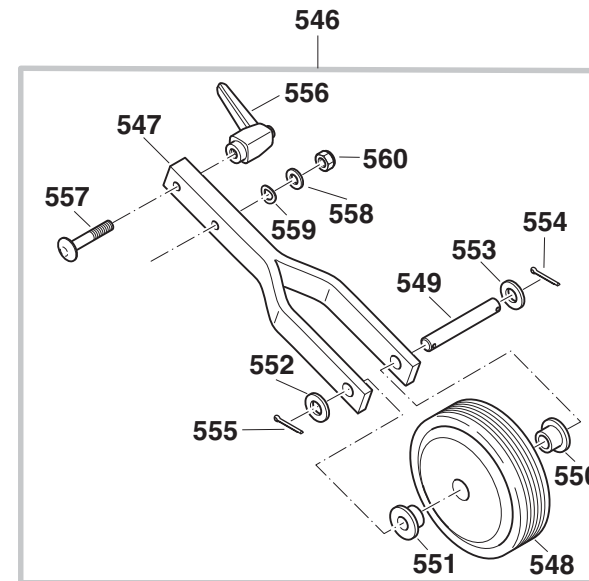
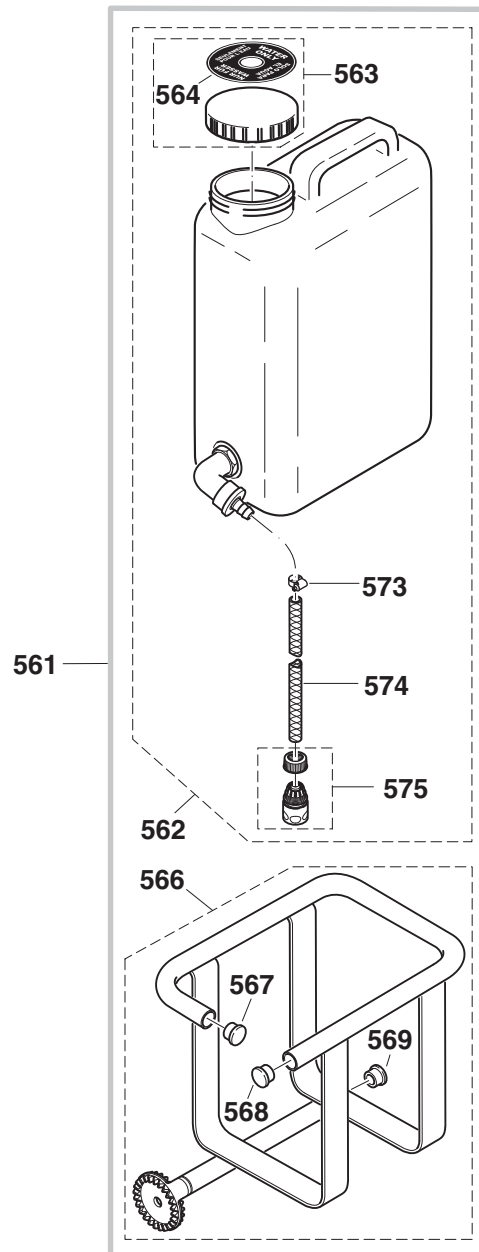

PC-6412 S, PC-6414 S, PC-7312 S, PC-7314 S,  
 PC-8114, PC-8116, PC-6412 S (UK), PC-7314 S (UK),  
 PC-8114 (UK), PC-8116 (UK), PC-6430 (USA), PC-6435  
 (USA), PC-7330 (USA), PC-7330 C (USA), PC-7335 (USA),  
 PC-7335 C (USA), PC-8135 (USA), PC-8140 (USA)

**12**

Führungswagen • Nicht im Lieferumfang  
 Guide trolley • Not included in delivery  
 Chariot de guidage • Non incl. dans la livrais  
 Carro de guía • No incluidos en entrega



Seite / Page	Pos.	PC-6412 S	PC-6414 S	PC-7312 S	PC-7314 S	PC-8114	PC-8116	PC-6412 S (UK)	PC-7314 S (UK)	PC-8114 (UK)	PC-8116 (UK)	PC-6430 (USA)	PC-6435 (USA)	PC-7330 (USA)	PC-7330 C (USA)	PC-7335 (USA)	PC-7335 C (USA)	PC-8135 (USA)	PC-8140 (USA)	Teil-Nr. Part No. No. de pièce No. de pieza	Hinweise Notes Renseign. Nota	Bezeichnung	Spezifikation Specification	Description	Désignation	Denominación
12	546	1	1	1	1	1	1	1	1	1	1	1	1	1	1	1	1	1	1	394 362 021		Tiefenbegrenzer kpl.		Depth limiter assy.	Limiteur de coupe cpl.	Limitador de profundidad cpl.
12	547	1	1	1	1	1	1	1	1	1	1	1	1	1	1	1	1	1	1	394 362 170		Radgabel		Wheel fork	Fourche	Horquilla de la rueda
12	548	1	1	1	1	1	1	1	1	1	1	1	1	1	1	1	1	1	1	394 362 140		Stahlrad kpl.		Steel wheel assy.	Roue en acier cpl.	Rueda de acero, cpl.
12	549	1	1	1	1	1	1	1	1	1	1	1	1	1	1	1	1	1	1	394 362 160		Achse	ø14	Axle	Axe	Eje
12	550	1	1	1	1	1	1	1	1	1	1	1	1	1	1	1	1	1	1	394 362 150		Laufbuchse		Bush	Douille	Casquillo
12	551	1	1	1	1	1	1	1	1	1	1	1	1	1	1	1	1	1	1	394 362 150		Laufbuchse		Bush	Douille	Casquillo
12	552	1	1	1	1	1	1	1	1	1	1	1	1	1	1	1	1	1	1	924 115 000		Scheibe	ø15	Washer	Rondelle	Arandela
12	553	1	1	1	1	1	1	1	1	1	1	1	1	1	1	1	1	1	1	924 115 000		Scheibe	ø15	Washer	Rondelle	Arandela
12	554	1	1	1	1	1	1	1	1	1	1	1	1	1	1	1	1	1	1	934 332 220		Splint		Cotter	Goupille fendue	Clavia
12	555	1	1	1	1	1	1	1	1	1	1	1	1	1	1	1	1	1	1	934 332 220		Splint		Cotter	Goupille fendue	Clavia
12	556	1	1	1	1	1	1	1	1	1	1	1	1	1	1	1	1	1	1	394 366 070		Schnellspannhebel	M8x83	Quick clamp lever	Levier de serrage rapide	Palanca de sujeción rápida
12	557	1	1	1	1	1	1	1	1	1	1	1	1	1	1	1	1	1	1	909 608 404		Flachrundschraube	M8x40	Screw	Vis	Tornillo
12	558	1	1	1	1	1	1	1	1	1	1	1	1	1	1	1	1	1	1	925 108 400		Scheibe	ø8,4	Washer	Rondelle	Arandela
12	559	1	1	1	1	1	1	1	1	1	1	1	1	1	1	1	1	1	1	926 208 001		Federscheibe	B8 DIN137	Spring washer	Rondelle élastique	Disco amortiguador
12	560	1	1	1	1	1	1	1	1	1	1	1	1	1	1	1	1	1	1	922 908 004		6kt-Mutter, selbstsichernd	M8	Nut	Écrou	Tuerca
12	561	1	1	1	1	1	1	1	1	1	1	1	1	1	1	1	1	1	1	394 365 022		Tankset, schwarz		Water tank cpl.	Réservoir d'eau cpl.	Tanque de agua cpl.
12	562	1	1	1	1	1	1	1	1	1	1	1	1	1	1	1	1	1	1	394 365 250		Wassertank kpl.	16 l	Water tank cpl.	Réservoir d'eau cpl.	Tanque de agua cpl.
12	563	1	1	1	1	1	1	1	1	1	1	1	1	1	1	1	1	1	1	394 365 295		Tankdeckel kpl.		Tank cover cpl.	Couvercle de réservoir cpl.	Tapa del tanque cpl.
12	564	1	1	1	1	1	1	1	1	1	1	1	1	1	1	1	1	1	1	980 114 921		Schild	WATER ONLY	Label	Plaque	Calcomania
12	566	1	1	1	1	1	1	1	1	1	1	1	1	1	1	1	1	1	1	394 365 310		Tankhalter, schwarz		Tank holder	Porte-réservoir	Portador del depósito de agua
12	567	1	1	1	1	1	1	1	1	1	1	1	1	1	1	1	1	1	1	394 365 320		Rohrendstopfen		Plug	Bouchon	Tapón
12	568	1	1	1	1	1	1	1	1	1	1	1	1	1	1	1	1	1	1	394 365 320		Rohrendstopfen		Plug	Bouchon	Tapón
12	569	1	1	1	1	1	1	1	1	1	1	1	1	1	1	1	1	1	1	394 365 200		Rohrendstopfen		Plug	Bouchon	Tapón
12	573	1	1	1	1	1	1	1	1	1	1	1	1	1	1	1	1	1	1	965 603 060		Schlauchschelle		Hose clip	Collier de serrage	Abrazadera
12	574	1	1	1	1	1	1	1	1	1	1	1	1	1	1	1	1	1	1	965 453 830		Schlauch	1/2", L=550mm	Hose	Tuyau	Tubo
12	575	1	1	1	1	1	1	1	1	1	1	1	1	1	1	1	1	1	1	964 802 271		Schlauchkupplung	STOP	Coupling sleeve	Manchon d'accouplement	Acoplamiento p. tubos

PC-6412 S, PC-6414 S, PC-7312 S, PC-7314 S,  
 PC-8114, PC-8116, PC-6412 S (UK), PC-7314 S (UK),  
 PC-8114 (UK), PC-8116 (UK), PC-6430 (USA), PC-6435  
 (USA), PC-7330 (USA), PC-7330 C (USA), PC-7335 (USA),  
 PC-7335 C (USA), PC-8135 (USA), PC-8140 (USA)

	<b>Zeichenerklärung</b>	<b>Key to symbols</b>	<b>Légende</b>	<b>Explicación de símbolos</b>
<b>=&gt; 1999999</b> <b>2000000 =&gt;</b> <b>2003.04 =&gt;</b> <b>TI 2003/07</b> <b>Acc.</b> <b>=</b> <b>{</b> <b>m</b> <b>Corr.</b>	Produktion bis Serien-Nr. Neues Teil ab Serien-Nr. Neues Teil ab Jahr / Monat Siehe Technische Information Jahr / Nr. Zubehör (nicht im Lieferumfang) Keine Serienausführung, jedoch verwendbar Beinhaltet Positions-Nr. Meterware Druckfehlerberichtigung	Production to serial number New part from serial number New part from Year / Month See Technical Information Year / No. Accessories (not included in the delivery inventory) No standard execution, may be used Contains item number Sold by the meter Error correction	Production jusqu'à n° de série Nouvelle pièce à partir du n° de série Nouvelle pièce à partir de année / mois Voir information technique année / n° Accessoires (non compris dans la livraison) Aucune exécut. en série, cependant utilisable contient n° de numéro Au mètre Rectification d'erreurs	Producción hasta N° de serie Pieza nueva a partir de N° de serie Pieza nueva a partir de año / mes Véase inform. técnico año / N° Accesorios (no incluido en la extensión del suministro) No es de serie, pero sirve Contiene pos N° Por metro Fe de erratas
	Änderungen vorbehalten	Specifications subject to change without notice	Changements sans préavis	Mejoras constructivas sin previo aviso