



# **PARTS CATALOG**

**TRIMMER/BRUSHCUTTER**

**SRM-222ES/U(37)**



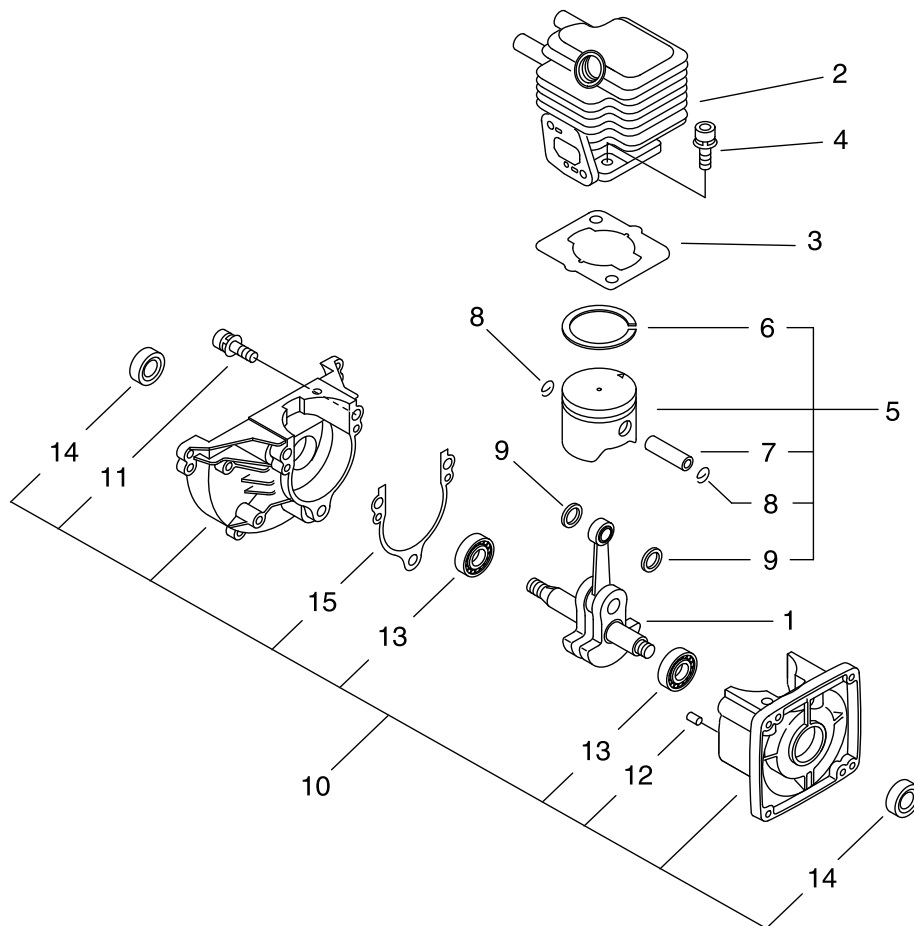

KEY	LV	PART NUMBER	Q'TY	DESCRIPTION	REMARKS
1		A011-000101	1	CRANKSHAFT,ASM	
2		A130-002100	1	CYLINDER	
3		101010-44332	1	GASKET, CYL. BASE	
4		900162-05022	2	BOLT, H.S. 5*22	
5		P021-007712	1	PISTON KIT	
6	+	A101-000090	1	RING,PISTON	
7	+	100013-11520	1	PIN, PISTON	
8	+	100015-04630	2	CIRCLIP, PISTON PIN	
9	+	100014-11520	2	SPACER, PISTON PIN	
10		100204-52133	1	CRANKCASE KIT	
11	+	900162-05028	3	BOLT, H.S. 5*28	
12	+	900330-40080	2	PIN F 4*8	
13	+	94095-36201	2	BEARING BALL	
14	+	100212-42031	2	OILSEAL	
15	+	100242-42030	1	GASKET, CRANKCASE	

# SRM-222ES/U(37) 2 FANCOVER, CYLINDER COVER

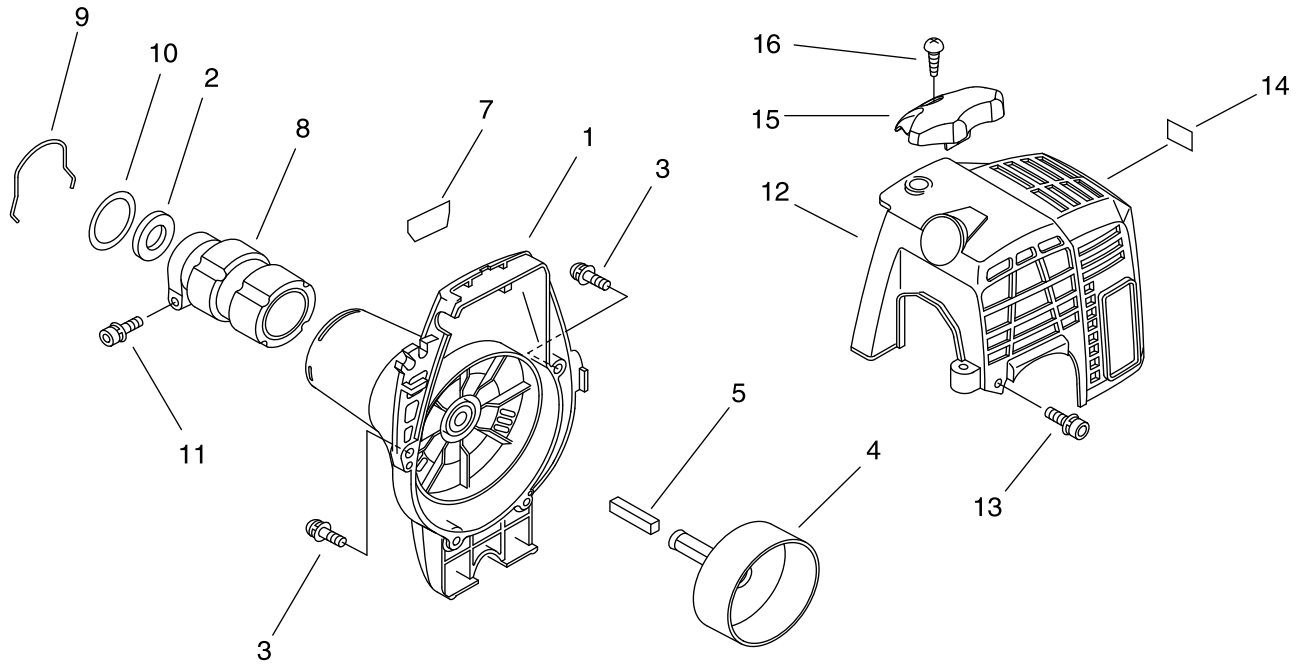

KEY	LV	PART NUMBER	Q'TY	DESCRIPTION	REMARKS
1		A172-000320	1	COVER,FAN	
2		175313-20430	1	RING, FELT	
3		91363-04016	3	SCREW	
4		175005-44331	1	DRUM, CLUTCH	
5		V376-000990	1	SPACER	
7		X547-002310	1	LABEL,ECHO	
8		A575-000110	1	FIXTURE,MAIN PIPE	
9		660316-55630	1	CLIP	
10		V315-000030	1	WASHER,CIRCULAR 30	
11		91118-05028	1	BOLT	
12		A160-000890	1	COVER,CYLINDER	
13		V202-000090	2	BOLT,4	
14		X505-002310	1	LABEL,CAUTION	
15		A162-000130	1	GUARD, TOP	
16		900253-05020	1	SCREW 5*20	

# SRM-222ES/U(37) 3 MAGNETO

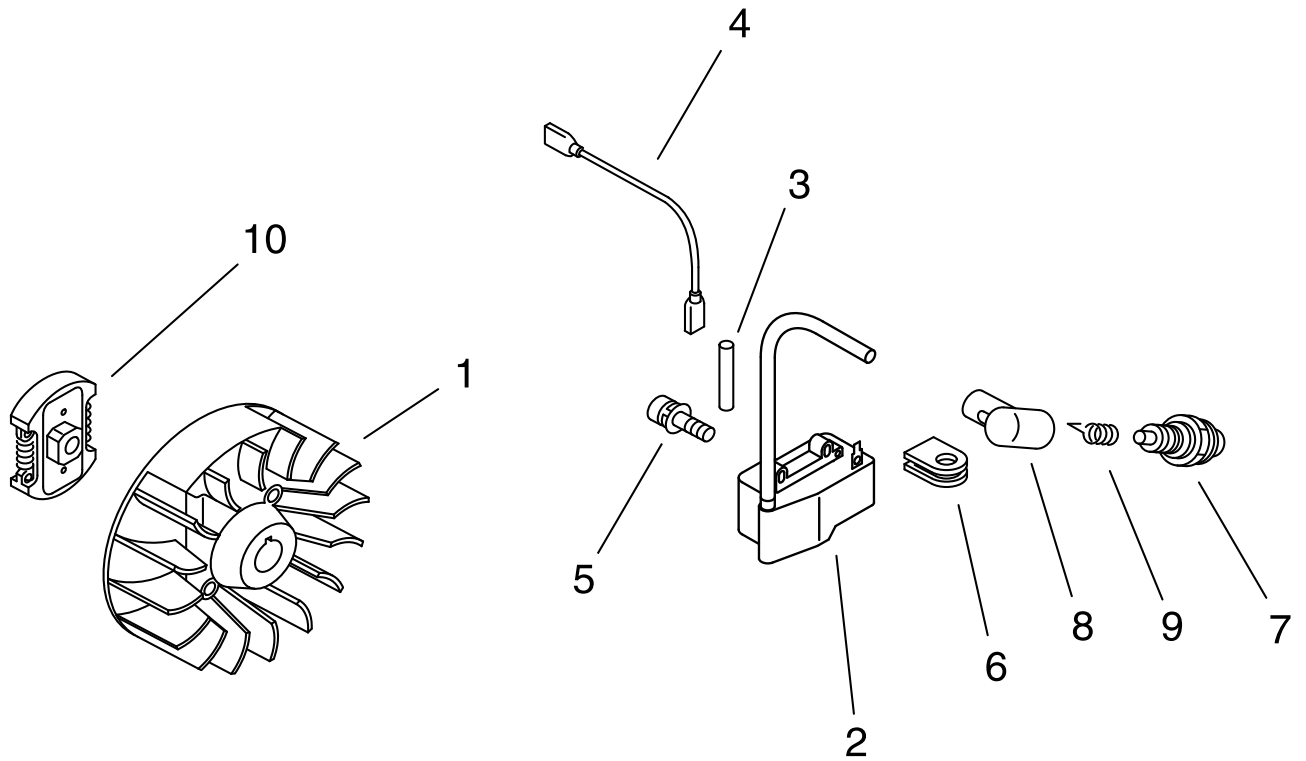

KEY	LV	PART NUMBER	Q'TY	DESCRIPTION	REMARKS
1		A409-000160	1	ROTOR,MAGNETO	
2		A411-000140	1	COIL,IGNITION	
3		V475-007300	1	TUBE	
4		162010-52830	1	LEAD, GROUND	
5		900162-04020	2	BOLT, H.S. 4*20	
6		156112-40630	1	GROMMET	
7		A425-000000	1	SPARKPLUG	
8		159012-03433	1	CAP, SPARK PLUG	
9		159011-03432	1	COIL, SPARK PLUG	
10		175000-56831	1	CLUTCH ASSEMBLY	

# SRM-222ES/U(37) 4 AIR CLEANER

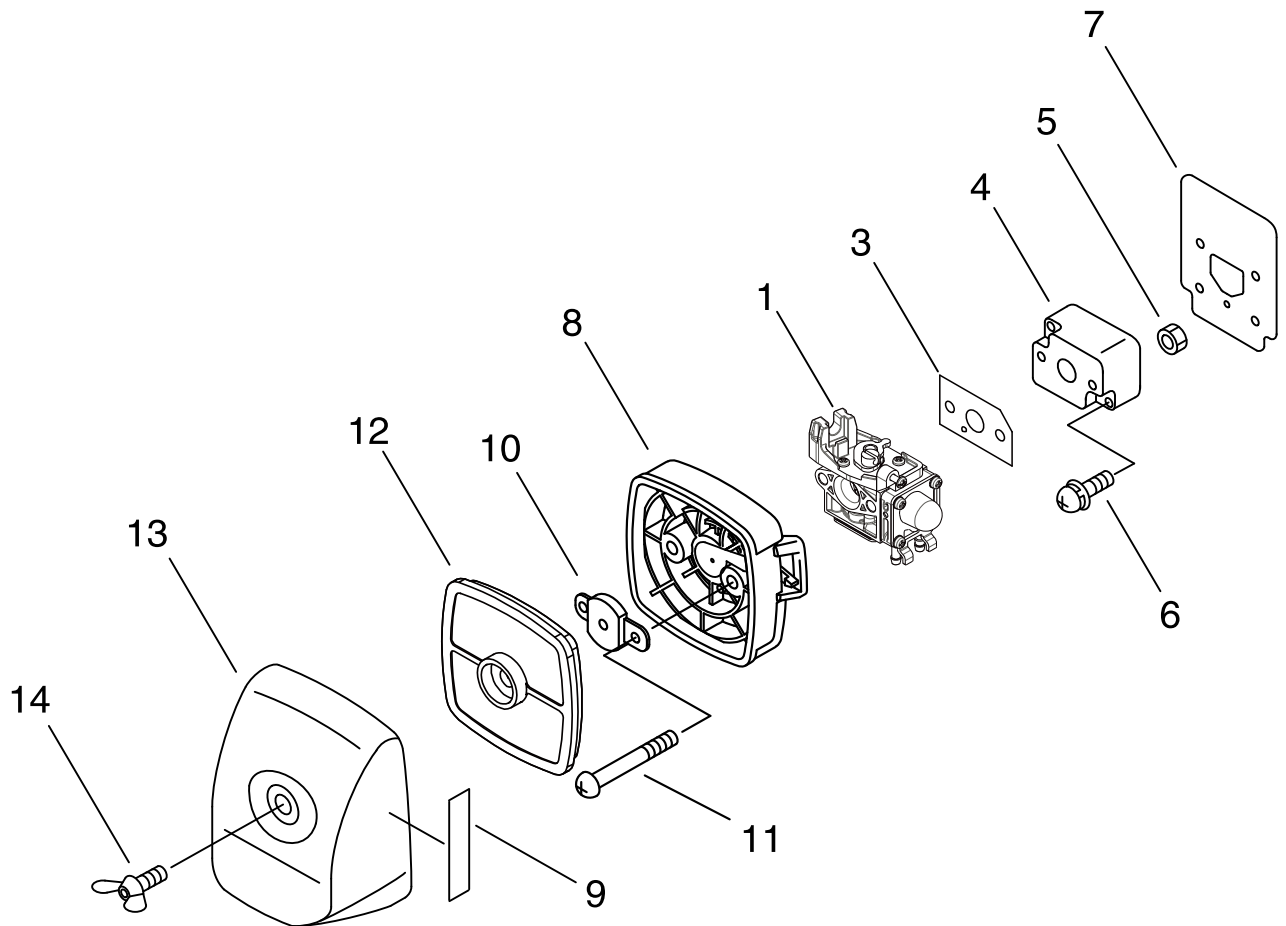

KEY	LV	PART NUMBER	Q'TY	DESCRIPTION	REMARKS
1		A021-003880	1	CARBURETOR,DIAPHRAGM	
3		V103-001390	1	GASKET,INTAKE	
4		130017-44331	1	INSULATOR	
5		900500-00005	2	NUT 5	
6		900238-05022	2	SCREW 5*22	
7		V103-001640	1	GASKET,INTAKE	
8		P021-004480	1	CASE, AIR CLEANER	
9		890332-52730	1	LABEL, CHOKE	
10		129011-52730	1	PLATE, PREVENT	
11		900220-05065	2	SCREW 5*65	
12		A226-001410	1	ELEMENT,AIR FILTER	
13		130313-05863	1	LID, AIR CLEANER	
14		210417-52730	1	BOLT, WING	

# SRM-222ES/U(37) 5 FUEL TANK

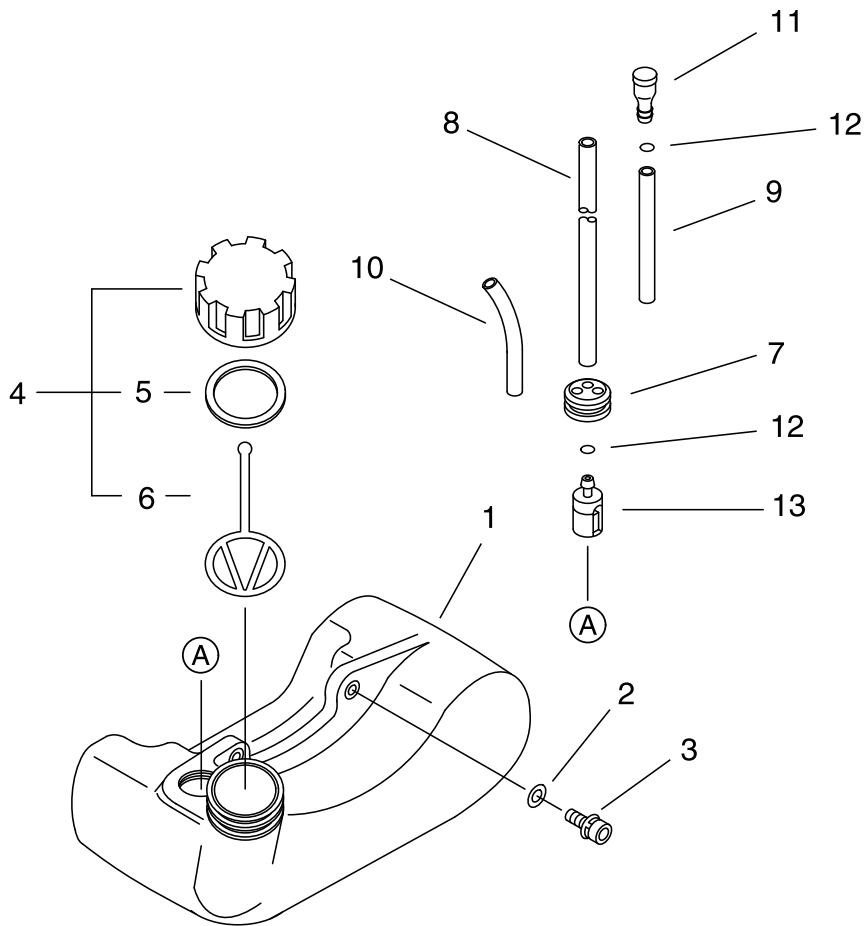

KEY	LV	PART NUMBER	Q'TY	DESCRIPTION	REMARKS
1		A350-000480	1	TANK, FUEL	
2		900603-00005	2	WASHER 5	
3		91118-05020	2	BOLT	
4		P021-012210	1	CAP,FUEL ASY	
5	+	131016-55830	1	GASKET, FUEL CAP	
6	+	A365-000060	1	CONNECTOR,CAP	
7		132115-46730	1	GROMMET, FUEL	
8		V471-001190	1	PIPE	
9		V471-001200	1	PIPE	
10		132012-56030	1	PIPE	
11		A356-000031	1	VALVE,CHECK	
12		V490-001240	2	CLIP	
13		131205-07320	1	STRAINER, FUEL	

**SRM-222ES/U(37) 6 MUFFLER**

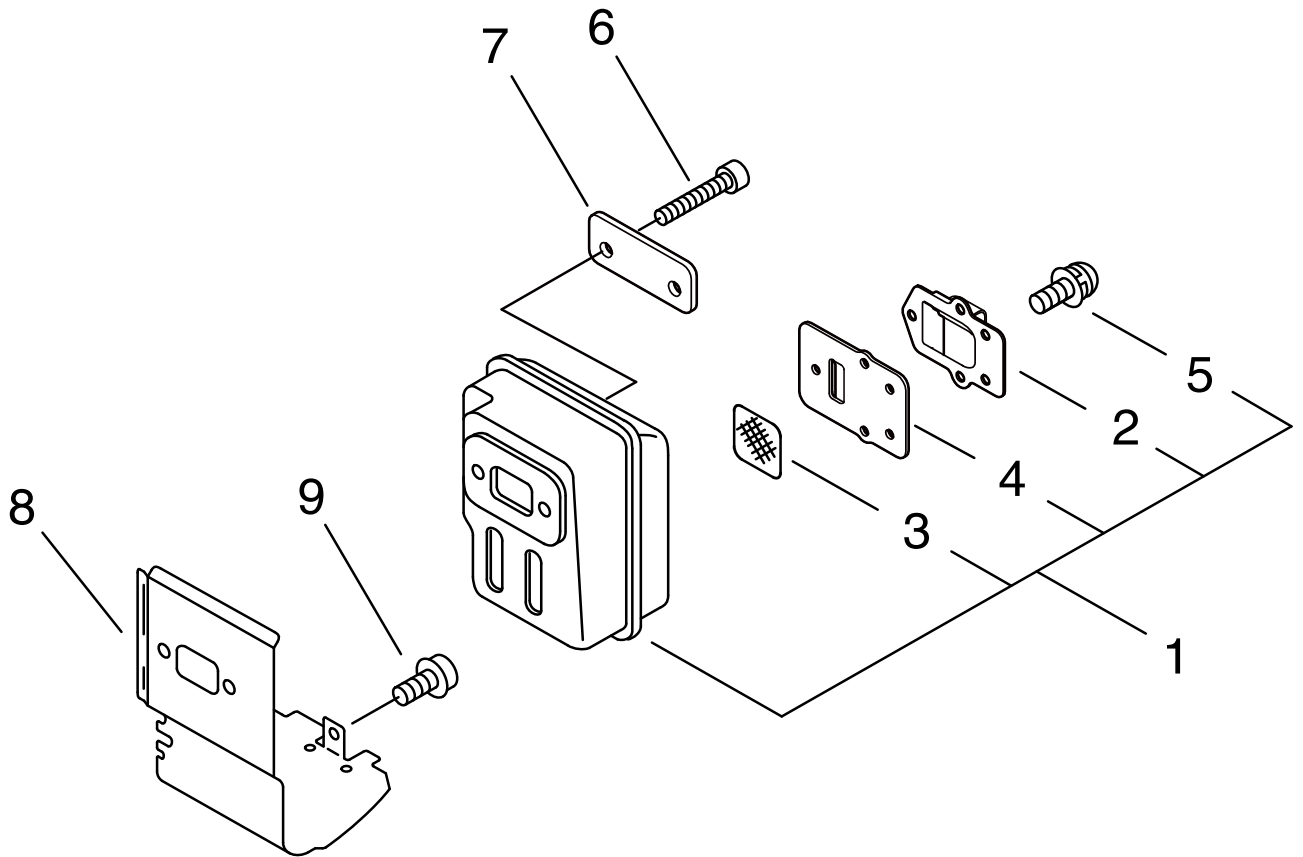

KEY	LV	PART NUMBER	Q'TY	DESCRIPTION	REMARKS
1		P021-037630	1	MUFFLER ASY	
2	+	A313-000600	1	GUIDE,EXH	
3	+	145862-40630	1	SCREEN, MUFFLER	
4	+	V104-001760	1	GASKET,EXHAUST	
5	+	91367-04010	5	SCREW	
6		900105-05055	2	BOLT, H.S. 5*55	
7		V150-000371	1	PLATE,EYE	
8		V104-000500	1	GASKET,EXHAUST	
9		91121-04008	1	BOLT, FLANGE	

# SRM-222ES/U(37) 7 RECOIL STARTER

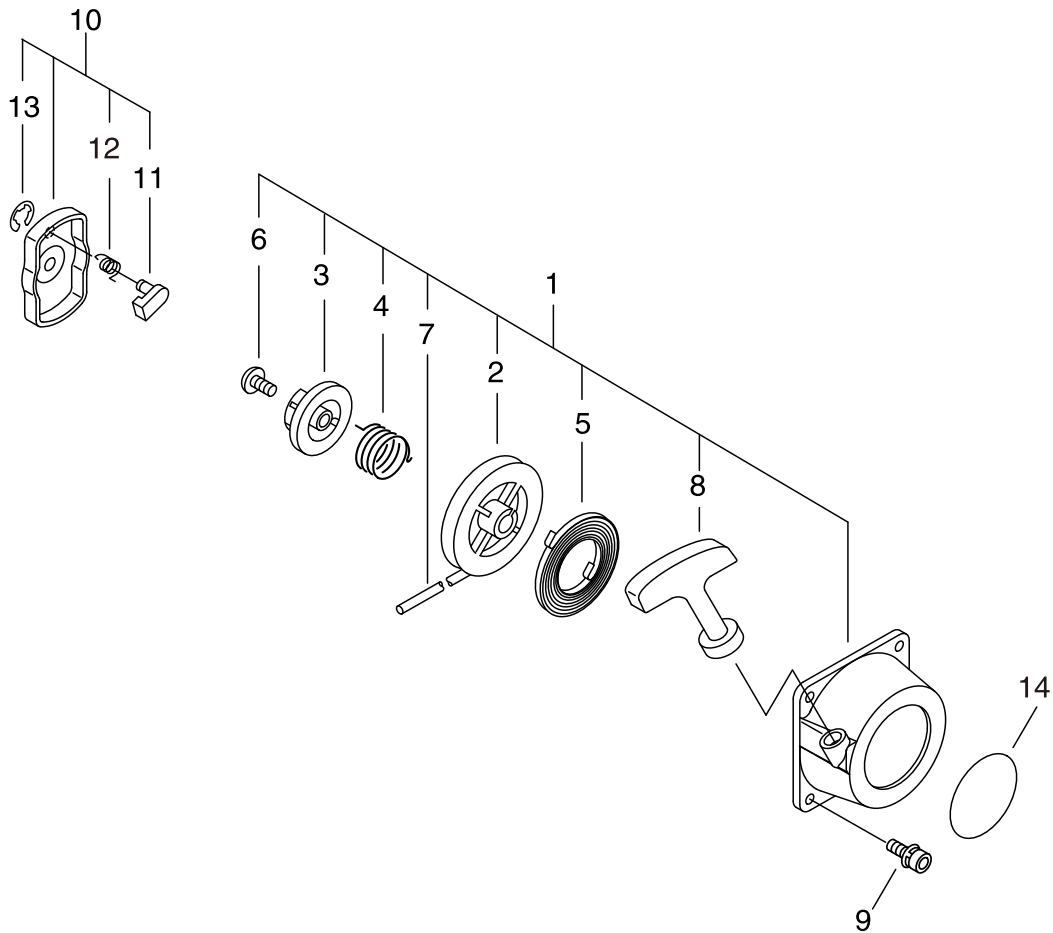

KEY	LV	PART NUMBER	Q'TY	DESCRIPTION	REMARKS
1		A051-001411	1	STARTER, RECOIL ASY	
2	+	P022-034040	1	DRUM, STARTER	
3	+	P022-034030	1	PLATE, CAM	
4	+	P022-008270	1	SPRING, DAMPER	
5	+	P022-019680	1	SPRING, SPIRAL	
6	+	177236-61830	1	SCREW	
7	+	P022-025730	1	ROPE, STARTER	
8	+	P022-023170	1	GRIP, STARTER	
9		V202-000090	2	BOLT, 4	
10		A052-000180	1	PULLEY, ASM STARTER	
11	+	P022-006850	2	PAWL, STARTER	
12	+	P022-006510	2	SPRING, RETURN	
13	+	P022-002100	2	E-RING	
14		X502-000890	1	LABEL, ECHO	



# SRM-222ES/U(37) 8 GEAR CASE

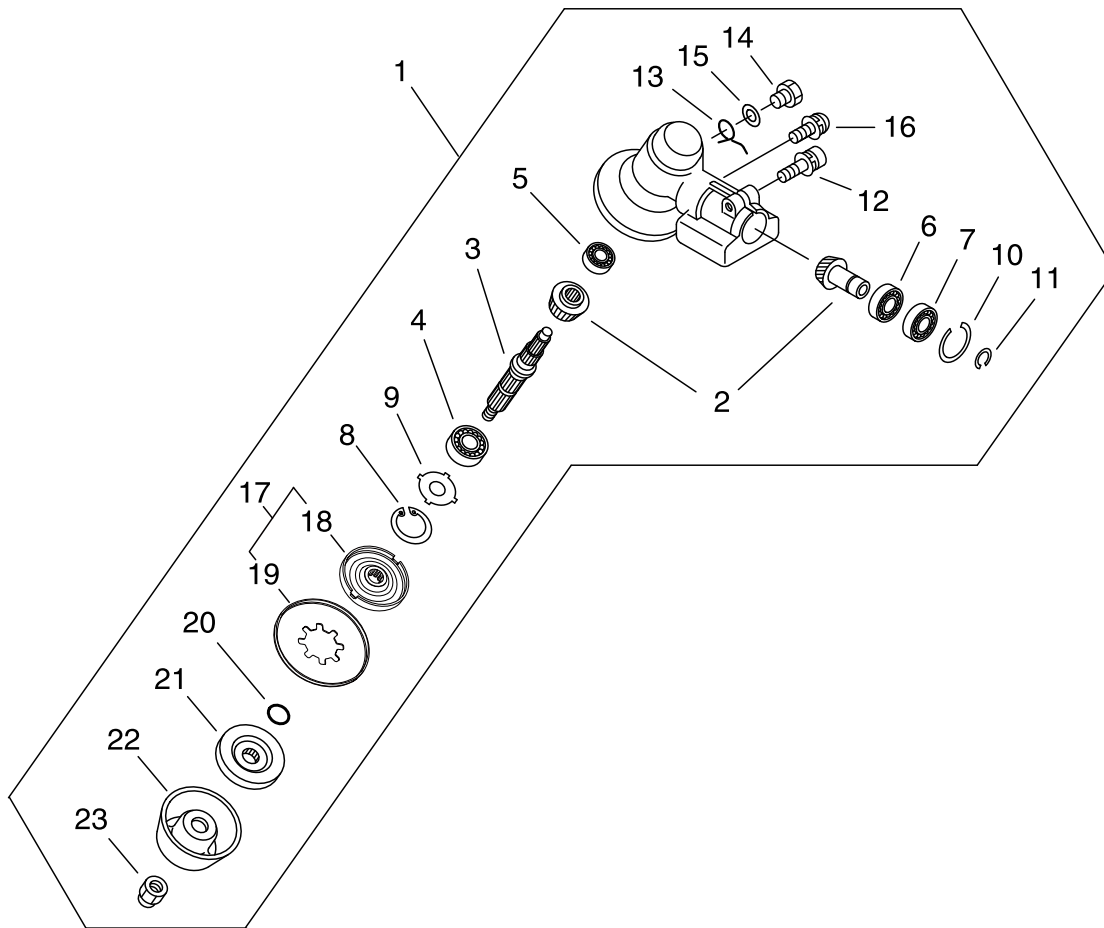

KEY	LV	PART NUMBER	Q'TY	DESCRIPTION	REMARKS
1		P021-005785	1	HOUSING ASY,GEAR	
2	+	610300-42330	1	GEAR SET	
3	+	610310-56831	1	SHAFT, P.T.O.	
4	+	900812-06201	1	BEARING, BALL 6201	
5	+	94060-00626	1	BEARING, BALL	
6	+	94060-06900	1	BEARING BALL	
7	+	94063-06900	1	BEARING BALL	
8	+	900702-00032	1	CIRCLIP 32	
9	+	610444-56830	1	WASHER	
10	+	900702-00022	1	CIRCLIP 22	
11	+	900706-00010	1	CIRCLIP 10	
12	+	91118-06025	1	BOLT	
13	+	V452-001310	1	SPRING,TORSION	
14	+	610434-50031	1	BOLT 8* 8	
15	+	900603-50008	1	WASHER	
16	+	900242-05010	1	SCREW 5*10	
17	+	610313-52932	1	FIXTURE,BLADE	
18	++	610313-52132	1	FIXTURE,BLADE	
19	++	610352-56830	1	PLATE, CUP	
20	+	900720-00012	1	O-RING 12	
21	+	610314-52130	1	PLATE, ADAPTER (L)	
22	+	699229-56830	1	PLATE, COVER	
23	+	610320-52130	1	NUT 10	

# SRM-222ES/U(37) 9 MAIN PIPE

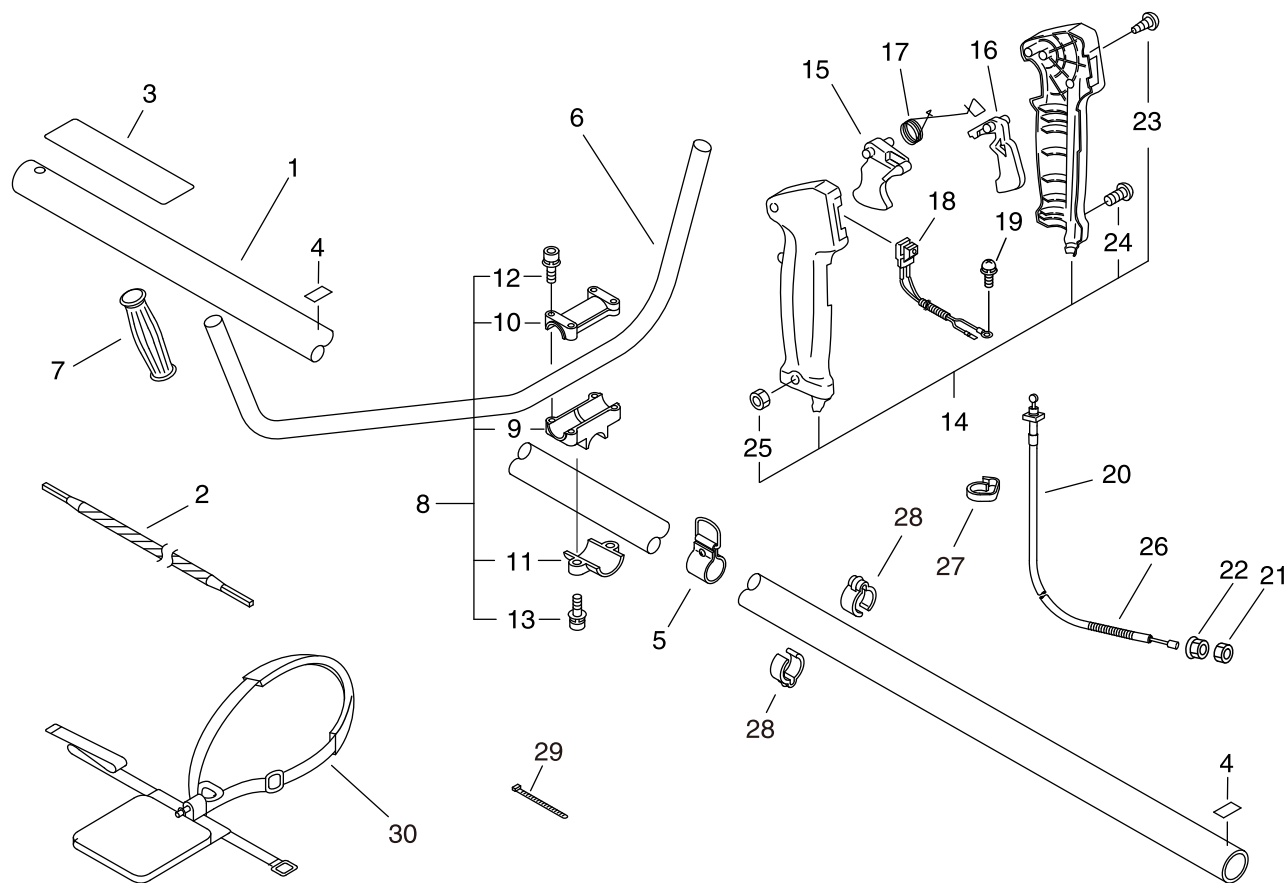

KEY	LV	PART NUMBER	Q'TY	DESCRIPTION	REMARKS
1		610206-44730	1	HOUSING ASSY, D.SHFT	
2		610013-44730	1	SHAFT, FLEXIBLE	
3		890617-43130	1	LABEL,CAUTION	
4		890152-04930	2	LABEL, CAUTION	
5		C063-000040	1	HOOK,LIFTING	
6		C400-000211	1	HANDLE,FRONT	
7		351311-02330	1	GRIP, HANDLE	
8		P021-041510	1	BRACKET ASY, HANDLE	
9	+	351312-22331	1	BRACKET, HANDLE (C)	
10	+	351313-22332	1	BRACKET, HANDLE (U)	
11	+	351314-22332	1	BRACKET, HANDLE (L)	
12	+	91118-05025	4	BOLT	
13	+	91118-05025	2	BOLT	
14		351102-47530	1	GRIP ASSY, F-HANDLE	
23	+	900246-03025	4	SCREW 3*25	
24	+	900220-05030	1	SCREW 5*30	
25	+	900500-00005	1	NUT 5	
15		178010-05960	1	CONTROL, THROTTLE	
16		178012-05960	1	LOCKOUT, THROTTLE	
17		178013-35631	1	SPRING, THR. LOCK	
18		A440-000881	1	SWITCH, ON OFF	
19		91363-04016	1	SCREW	
20		V430-002300	1	CABLE,BOWDEN	
21		900502-00006	1	NUT 6 (3N)	
22		900518-00006	1	NUT, FLANGE	
26		V475-001500	1	TUBE	

**SRM-222ES/U(37) 9 MAIN PIPE**

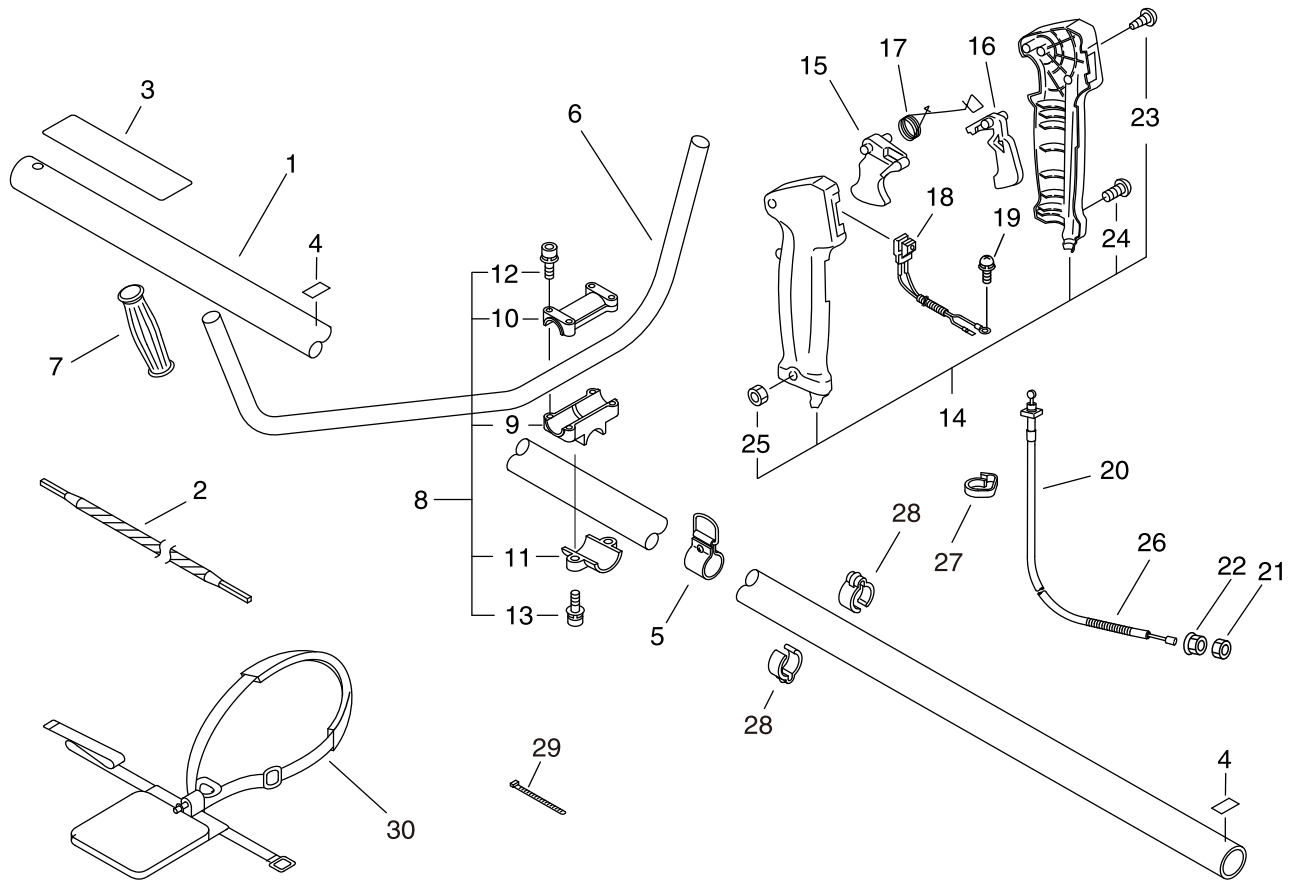

KEY	LV	PART NUMBER	Q'TY	DESCRIPTION	REMARKS
27		159112-09961	1	CLIP	
28		224924-52130	2	CLIP	
29		V495-002690	2	BAND	
30		301001-44731	1	HARNESS, SHOULDER	

# SRM-222ES/U(37) 10 SHIELD

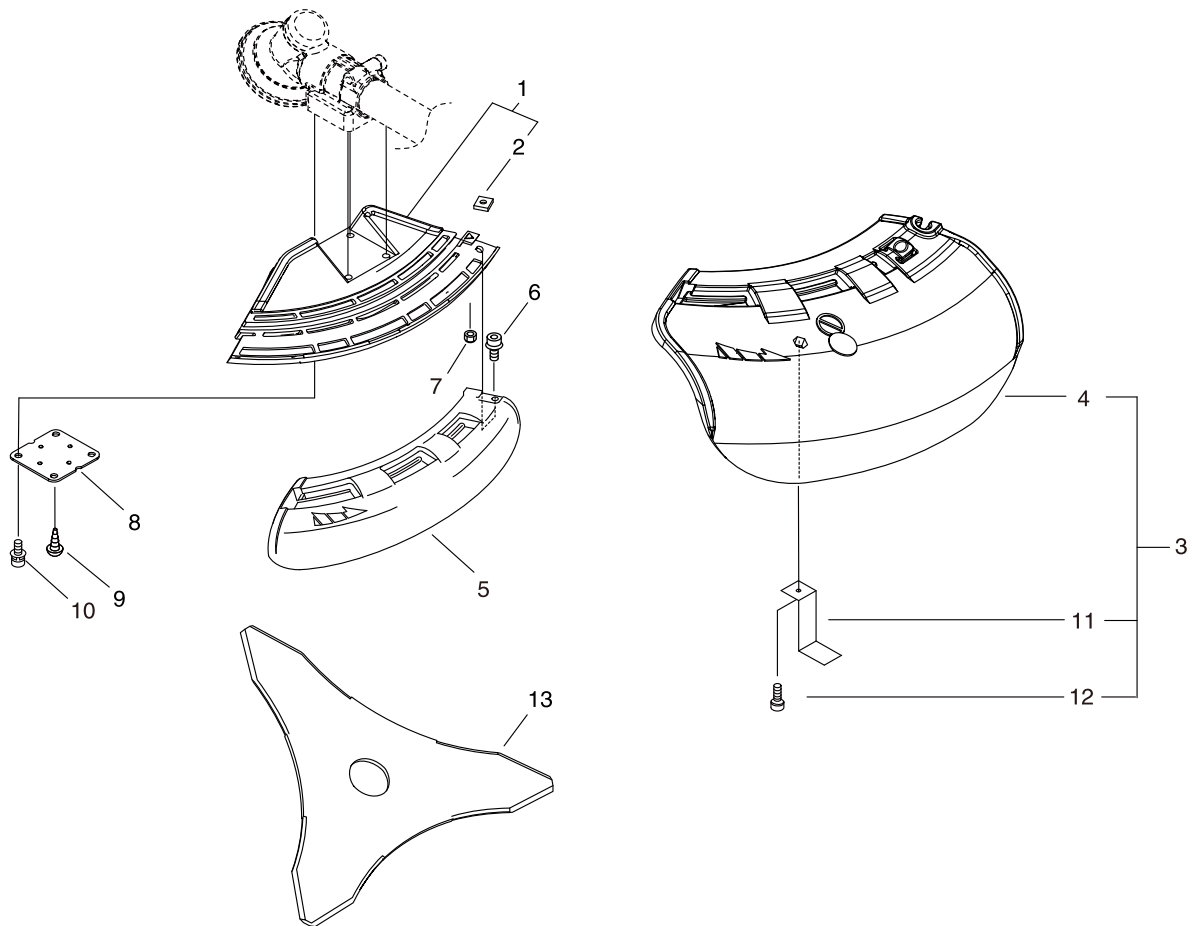

KEY	LV	PART NUMBER	Q'TY	DESCRIPTION	REMARKS
1		C550-000511	1	SHIELD,BLADE	
2	+	900565-00005	1	NUT	
3		P021-002625	1	SHIELD,BLADE(W/KNIFE)	
4	+	C550-000570	1	SHIELD,BLADE	
11	+	C554-000000	1	KNIFE,CORD	
12	+	91118-05018	1	BOLT	
5		C550-000551	1	SHIELD,BLADE	
6		91121-05025	1	BOLT, FLANGE	
7		900562-00005	1	NUT, LOCK	
8		C552-000200	1	PLATE, SHIELD	
9		91316-04010	1	SCREW	
10		V203-001980	4	BOLT,5	
13		P021-014310	1	SAW,BUSH CUTTER	

# SRM-222ES/U(37) 11 ACCESSORIES

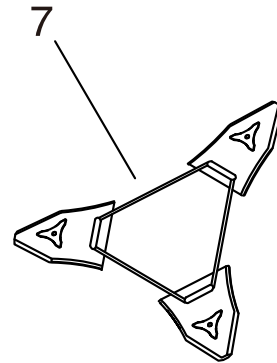
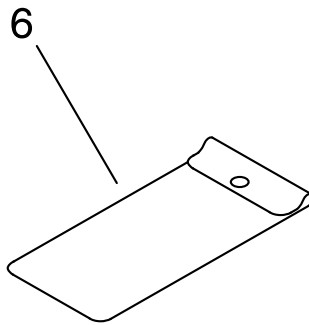
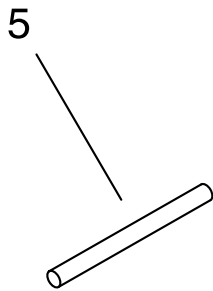
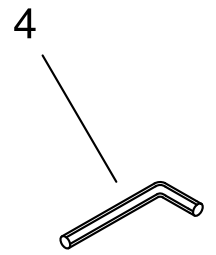
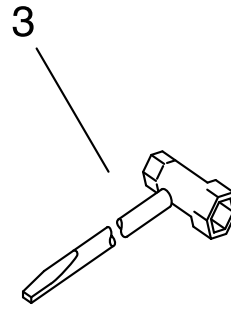
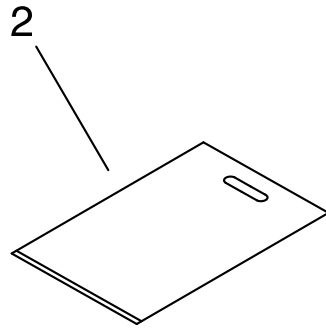
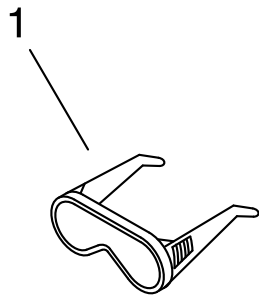

KEY	LV	PART NUMBER	Q'TY	DESCRIPTION	REMARKS
1		X690-000050	1	GOGGLE	
2		X698-000040	1	TOOL,CASE	
3		895410-02830	1	WRENCH, W/S. DRIVER	
4		X605-000100	1	TOOL,L WRENCH	
5		X606-000080	1	TOOL,BAR	
6		898510-07130	1	BAG, TOOL	
7		X495-000270	1	SCABBARD,BLADE	

# SRM-222ES/U(37) 12 CARBURETOR

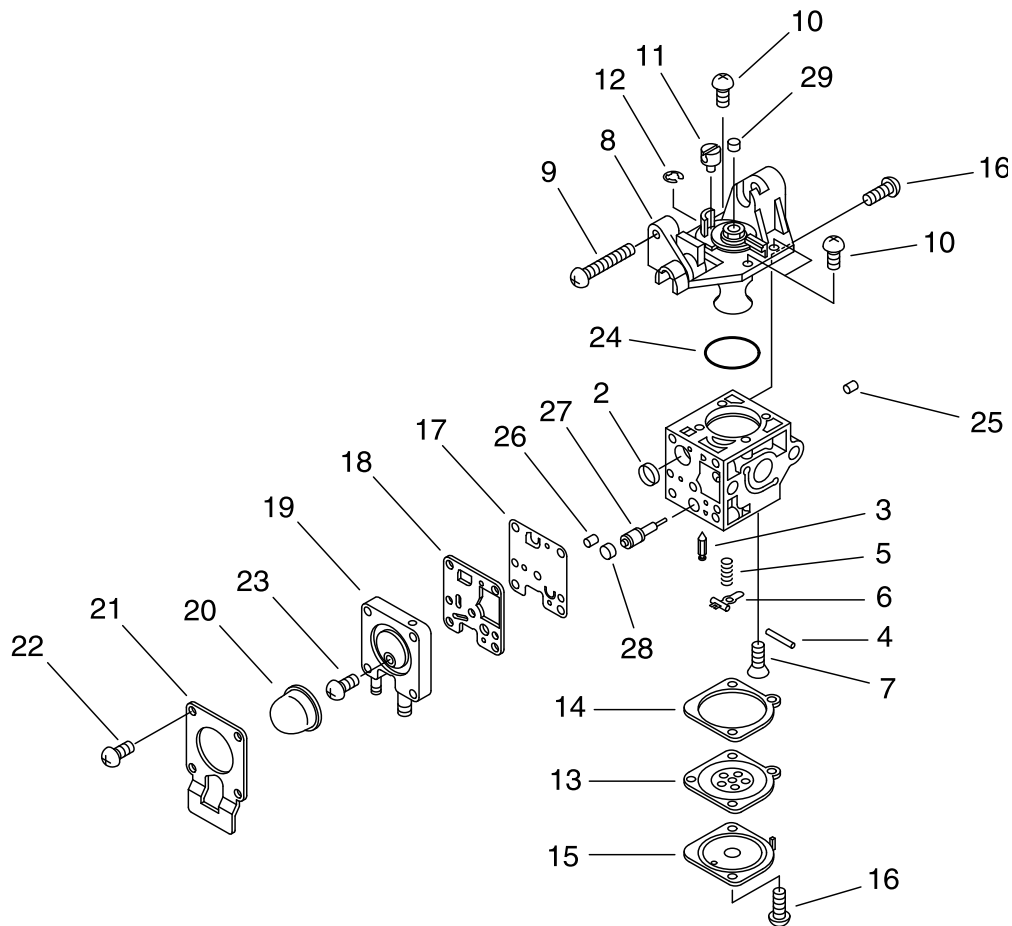

KEY	LV	PART NUMBER	Q'TY	DESCRIPTION	REMARKS
		A021-003880	1	CARBURETOR,DIAPHRAGM	
2	+	P005-000010	1	STRAINER	
3	+	125337-08260	1	VALVE, INLET NEEDLE	
4	+	125338-13930	1	PIN, METERING ARM	
5	+	P005-002430	1	SPRING, MET. LEVER	
6	+	125323-08260	1	ARM, VALVE	
7	+	125339-42030	1	SCREW	
8	+	P005-002460	1	COVER ASY, ROTOR	
9	+	P005-000100	1	SCREW,THROTTLEADJUST	
10	+	125344-13931	3	SCREW	
11	+	P005-001240	1	POST	
12	+	P005-000190	1	E-RING	
13	+	P005-002230	1	DIAPHRAGM ,METERING	
14	+	P005-000200	1	GASKET, METERING	
15	+	125342-52130	1	COVER, DIAPHRAGM	
16	+	125344-52130	3	SCREW	
17	+	P005-000510	1	DIAPHRAGM, PUMP	
18	+	P005-000520	1	GASKET, PUMP	
19	+	P005-001890	1	BASE, ASY PRIMER	
20	+	125381-46730	1	PUMP, PRIMING	
21	+	P005-000250	1	RETAINER	
22	+	P005-001900	4	SCREW	
23	+	P005-000270	1	SCREW	
24	+	P005-000280	1	O-RING	
25	+	P005-001000	1	ROLLER, GUIDE	
26	+	P005-001250	1	RETAINER,PLUG BALL	

# SRM-222ES/U(37) 12 CARBURETOR

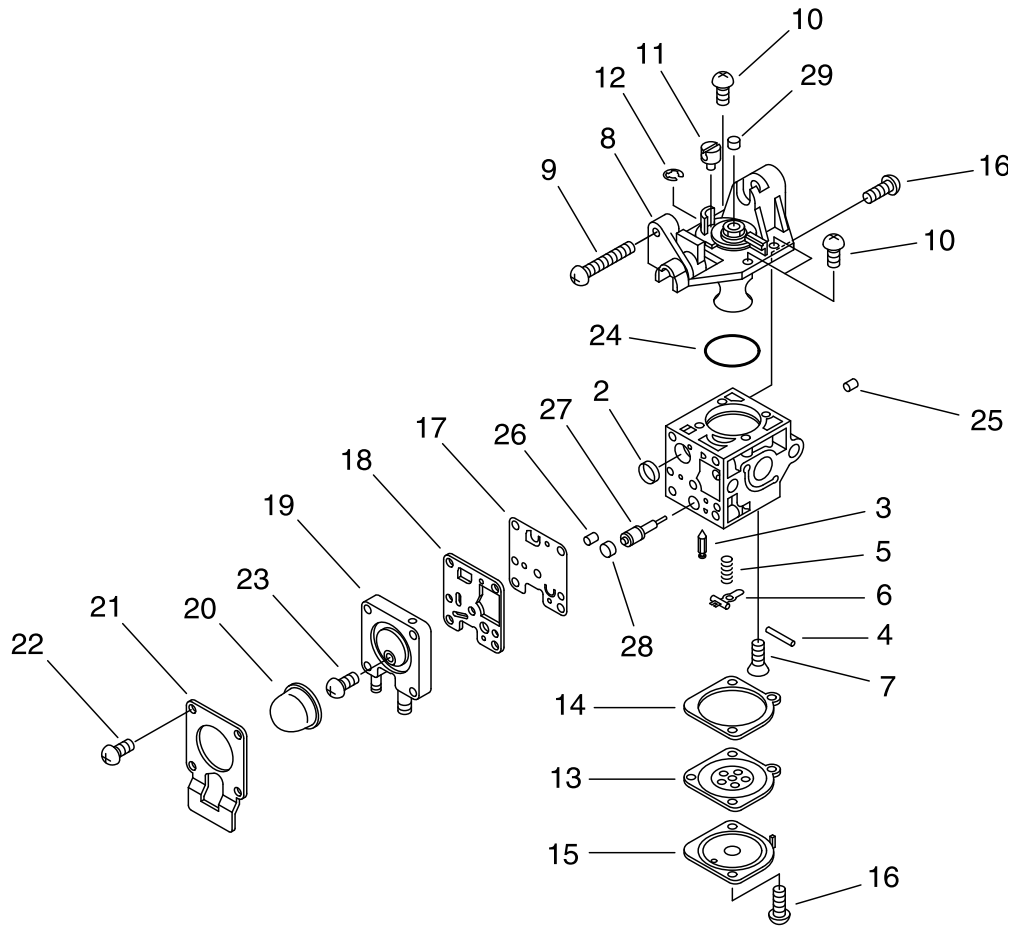

KEY	LV	PART NUMBER	Q'TY	DESCRIPTION	REMARKS
27	+	P005-001260	1	SCREW,MAINN MIXTURE	
28	+	P005-001270	1	PLUG, H AJUST SCREW	
29	+	A259-000010	1	CAP,LIMITER	

**Index**

<b>Patrs Number</b>	<b>Key No.</b>	<b>Patrs Number</b>	<b>Key No.</b>	<b>Patrs Number</b>	<b>Key No.</b>
100013-11520	1 - 7	610314-52130	8 - 21	94060-06900	8 - 6
100014-11520	1 - 9	610320-52130	8 - 23	94063-06900	8 - 7
100015-04630	1 - 8	610352-56830	8 - 19	94095-36201	1 - 13
100204-52133	1 - 10	610434-50031	8 - 14	A011-000101	1 - 1
100212-42031	1 - 14	610444-56830	8 - 9	A021-003880	4 - 1
100242-42030	1 - 15	660316-55630	2 - 9	A021-003880	12 -
101010-44332	1 - 3	699229-56830	8 - 22	A051-001411	7 - 1
125323-08260	12 - 6	890152-04930	9 - 4	A052-000180	7 - 10
125337-08260	12 - 3	890332-52730	4 - 9	A101-000090	1 - 6
125338-13930	12 - 4	890617-43130	9 - 3	A130-002100	1 - 2
125339-42030	12 - 7	895410-02830	11 - 3	A160-000890	2 - 12
125342-52130	12 - 15	898510-07130	11 - 6	A162-000130	2 - 15
125344-13931	12 - 10	900105-05055	6 - 6	A172-000320	2 - 1
125344-52130	12 - 16	900162-04020	3 - 5	A226-001410	4 - 12
125381-46730	12 - 20	900162-05022	1 - 4	A259-000010	12 - 29
129011-52730	4 - 10	900162-05028	1 - 11	A313-000600	6 - 2
130017-44331	4 - 4	900220-05030	9 - 24	A350-000480	5 - 1
130313-05863	4 - 13	900220-05065	4 - 11	A356-000031	5 - 11
131016-55830	5 - 5	900238-05022	4 - 6	A365-000060	5 - 6
131205-07320	5 - 13	900242-05010	8 - 16	A409-000160	3 - 1
132012-56030	5 - 10	900246-03025	9 - 23	A411-000140	3 - 2
132115-46730	5 - 7	900253-05020	2 - 16	A425-000000	3 - 7
145862-40630	6 - 3	900330-40080	1 - 12	A440-000881	9 - 18
156112-40630	3 - 6	900500-00005	4 - 5	A575-000110	2 - 8
159011-03432	3 - 9	900500-00005	9 - 25	C063-000040	9 - 5
159012-03433	3 - 8	900502-00006	9 - 21	C400-000211	9 - 6
159112-09961	9 - 27	900518-00006	9 - 22	C550-000511	10 - 1
162010-52830	3 - 4	900562-00005	10 - 7	C550-000551	10 - 5
175000-56831	3 - 10	900565-00005	10 - 2	C550-000570	10 - 4
175005-44331	2 - 4	900603-00005	5 - 2	C552-000200	10 - 8
175313-20430	2 - 2	900603-50008	8 - 15	C554-000000	10 - 11
177236-61830	7 - 6	900702-00022	8 - 10	P005-000010	12 - 2
178010-05960	9 - 15	900702-00032	8 - 8	P005-000100	12 - 9
178012-05960	9 - 16	900706-00010	8 - 11	P005-000190	12 - 12
178013-35631	9 - 17	900720-00012	8 - 20	P005-000200	12 - 14
210417-52730	4 - 14	900812-06201	8 - 4	P005-000250	12 - 21
224924-52130	9 - 28	91118-05018	10 - 12	P005-000270	12 - 23
301001-44731	9 - 30	91118-05020	5 - 3	P005-000280	12 - 24
351102-47530	9 - 14	91118-05025	9 - 12	P005-000510	12 - 17
351311-02330	9 - 7	91118-05025	9 - 13	P005-000520	12 - 18
351312-22331	9 - 9	91118-05028	2 - 11	P005-001000	12 - 25
351313-22332	9 - 10	91118-06025	8 - 12	P005-001240	12 - 11
351314-22332	9 - 11	91121-04008	6 - 9	P005-001250	12 - 26
610013-44730	9 - 2	91121-05025	10 - 6	P005-001260	12 - 27
610206-44730	9 - 1	91316-04010	10 - 9	P005-001270	12 - 28
610300-42330	8 - 2	91363-04016	2 - 3	P005-001890	12 - 19
610310-56831	8 - 3	91363-04016	9 - 19	P005-001900	12 - 22
610313-52132	8 - 18	91367-04010	6 - 5	P005-002230	12 - 13
610313-52932	8 - 17	94060-00626	8 - 5	P005-002430	12 - 5



**Index**

<b>Patrs Number</b>	<b>Key No.</b>	<b>Patrs Number</b>	<b>Key No.</b>	<b>Patrs Number</b>	<b>Key No.</b>
P005-002460	12 - 8				
P021-002625	10 - 3				
P021-004480	4 - 8				
P021-005785	8 - 1				
P021-007712	1 - 5				
P021-012210	5 - 4				
P021-014310	10 - 13				
P021-037630	6 - 1				
P021-041510	9 - 8				
P022-002100	7 - 13				
P022-006510	7 - 12				
P022-006850	7 - 11				
P022-008270	7 - 4				
P022-019680	7 - 5				
P022-023170	7 - 8				
P022-025730	7 - 7				
P022-034030	7 - 3				
P022-034040	7 - 2				
V103-001390	4 - 3				
V103-001640	4 - 7				
V104-000500	6 - 8				
V104-001760	6 - 4				
V150-000371	6 - 7				
V202-000090	2 - 13				
V202-000090	7 - 9				
V203-001980	10 - 10				
V315-000030	2 - 10				
V376-000990	2 - 5				
V430-002300	9 - 20				
V452-001310	8 - 13				
V471-001190	5 - 8				
V471-001200	5 - 9				
V475-001500	9 - 26				
V475-007300	3 - 3				
V490-001240	5 - 12				
V495-002690	9 - 29				
X495-000270	11 - 7				
X502-000890	7 - 14				
X505-002310	2 - 14				
X547-002310	2 - 7				
X605-000100	11 - 4				
X606-000080	11 - 5				
X690-000050	11 - 1				
X698-000040	11 - 2				

# YAMABIKO CORPORATION

7-2 SUEHIROCHO 1-CHOME, OHME, TOKYO 198-8760, JAPAN  
PHONE: 81-428-32-6118. FAX: 81-428-32-6145.



12Fb  
No. 04-400