

**ECHO**

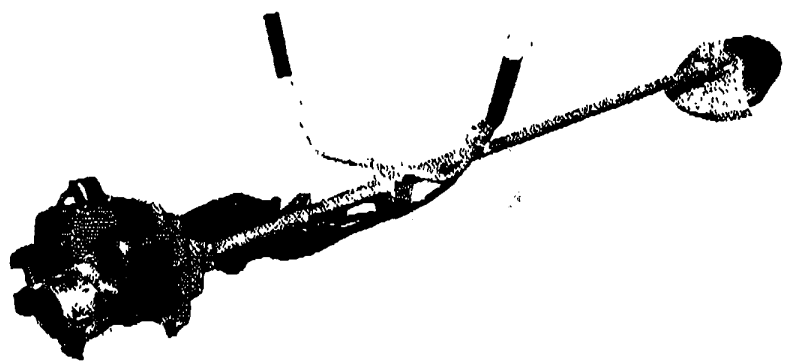

**OPERATOR'S MANUAL**

**ECHO  
TRIMMER/  
BRUSHCUTTER  
SRM-501DE**



898 571-0623 2

**CAUTION**

Read Rules for Safe Operation  
and Instructions Carefully

Table 2

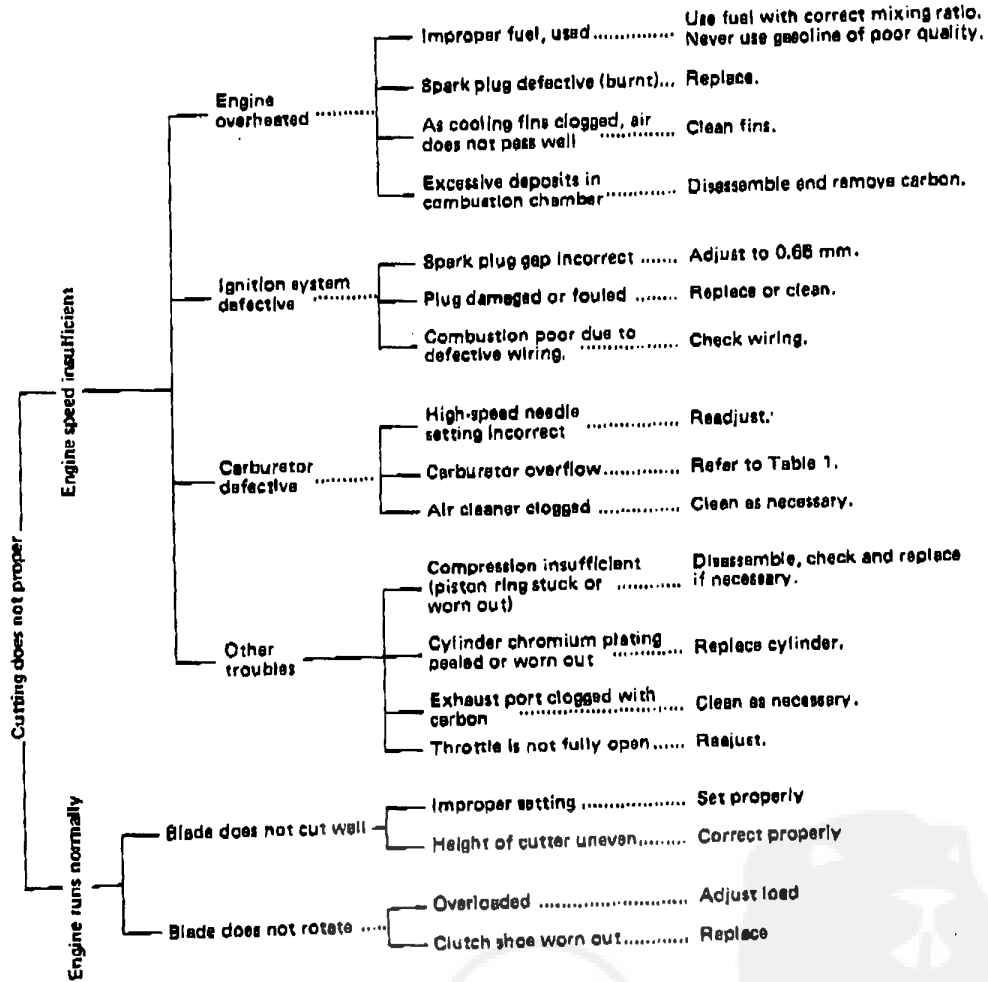

### STORAGE AFTER USE

- Inspect and adjust every part of the unit.
  - Completely clean every part, and repair, if necessary.
  - Apply thin coating of clean oil on metal parts to prevent rust.
  - Remove the blade and apply them sufficient oil coating and wrap them up in plastic sheet.
- Drain fuel tank, pull starter handle slowly a few times to drain fuel from carburetor.
- Pour a small amount of clean motor oil into spark plug hole, pull starter handle and then crank the engine until the TOP DEAD CENTER.
- Store in a dry area, free from dust.

## ON THIS PARTS LIST

- A) This list is supposed to contain  
 all of (1) the spare parts for the power unit an owner has purchased  
 and (2) the optional parts he may wish to purchase afterwards.
- B) When ordering the parts, please kindly use Part Number (11 digits) shown in this list.  
 (Note 1) Part Number is not given to such part as may be shown in the illustration but cannot be supplied as single part.  
 (Note 2) If Description of the part is stated along with Part Number when ordering, it will prevent error in shipment.
- C) How to read Parts List
- 1) This parts list contains all the standard and optional parts for which we can supply.
  - 2) Every part is shown according to the following formula.
    1. Corresponding key numbers are shown simultaneously on illustrations and tables.
    2. "Description"
 

Description (i.e. part name) is used as auxiliary when ordering or delivering parts. Therefore Description of Parts is printed on the right in simplified form, like the following:

Screw (SR4 x 25 with washer and spring washer) .....	Screw 4 x 25 W/W & SW
Screw (SR5 x 14 with washer) .....	Screw 5 x 14 W/W
Hexagon socket head bolt (5 x 18) .....	H.S.H. bolt 5 x 18
Hexagon head bolt (5 x 18) .....	Bolt 5 x 18
Nut (3N8) .....	Nut 8
Washer (4) .....	W 4
Spring washer (5) .....	SW 5
O-ring (P-22) .....	O-ring 22
Ball bearing (BB6201/C3) .....	Ball bearing 6201
  - 3) "Quantity" is the quantity required per one power unit.

### CONTENTS

(1) Power head .....	13
(2) Recoll starter, Magneto and Clutch .....	14
(3) Carburetor .....	15
(4) Driving shaft, Cutter head and Tools .....	17

POWER HEAD

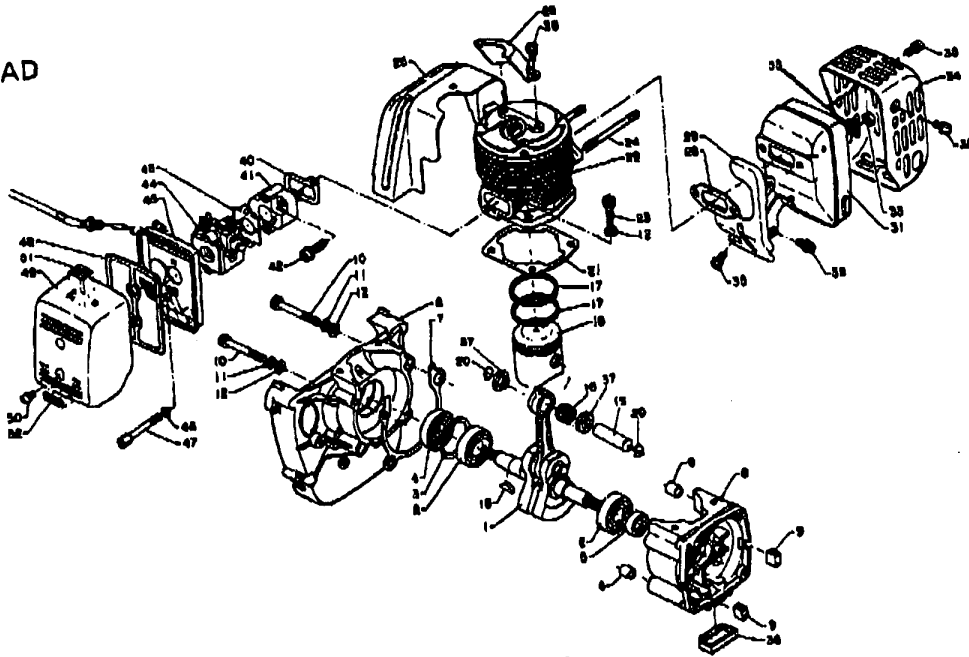

REF: 67990-100-000-00

Key No.	Part No.	Q'ty	Description	Key No.	Part No.	Q'ty	Description
1-1	100 100-0623 1	1	Crankshaft ass'y	1-36	131 927-0823 0	1	Cushion, fuel tank
2	900 810-3820 2	2	Ball bearing 8202	37	100 014-0823 0	2	Spacer, piston pin
3	900 702-0003 5	1	Circlip 35	40	130 010-0823 0	1	Gasket, insulator
4	100 212-0573 0	1	Oil seal	41	130 007-0623 0	1	Insulator
5	100 213-0573 0	1	Oil seal	42	900 240-0602 2	2	Screw 6x22 w/w
				43	130 016-0623 0	1	Gasket, carburetor
				44	123 000-0623 0	1	Carburetor ass'y
7	100 242-0623 0	2	Gasket, crankcase	45	130 307-0823 0	1	Body, air filter
8*	100 200-0623 0	1	Crankcase set	46	900 805-0000 5	2	Spring washer 5
8	-100 215-0623 0	1	Knock pin	47	130 021-0623 0	2	Bolt
9	100 223-0653 0	2	Plug, crankcase	48	130 310-0623 0	1	Air filter
10	900 105-0604 5	4	H.S.H. bolt 6x45	49	130 313-0623 0	1	Cover, air cleaner
11	900 805-0000 6	4	Spring washer 6	50	900 240-0400 8	3	Screw 4x8 w/w
12	900 800-0000 6	8	Washer 6	51	890 158-0823 0	1	Decal, caution
15	100 142-0031 0	1	Woodruff key	52	890 121-0031 0	1	Decal, choke
16	100 012-0023 0	1	Needle bearing	53	145 842-0823 0	2	Washer
17	100 011-0343 0	2	Piston ring	Remarks: B* Consisting of 8A and 8B.			
18	100 010-0623 2	1	Piston				
19	100 013-0823 0	1	Piston pin				
20	100 015-0023 0	2	Circlip, piston pin				
21	101 010-0623 0	1	Gasket, cylinder base				
22	101 011-0823 0	1	Cylinder				
23	900 105-0602 0	4	H.S.H. bolt 6x20				
24	101 014-0823 1	2	Stud bolt				
26	101 514-0623 0	1	Cylinder cover				
26	159 912-0823 0	1	Guard, spark plug				
28	145 510-0823 0	1	Gasket, muffler				
29	145 667-0823 0	1	Muffler cover, inner				
31	145 605-0823 0	1	Muffler				
33	145 710-0023 0	2	Lock nut				
34	145 821-0823 0	1	Muffler cover				
36	900 242-0601 0	7	Screw 6x10 w/w, SW				

# RECOIL STARTER, MAGNETO AND CLUTCH

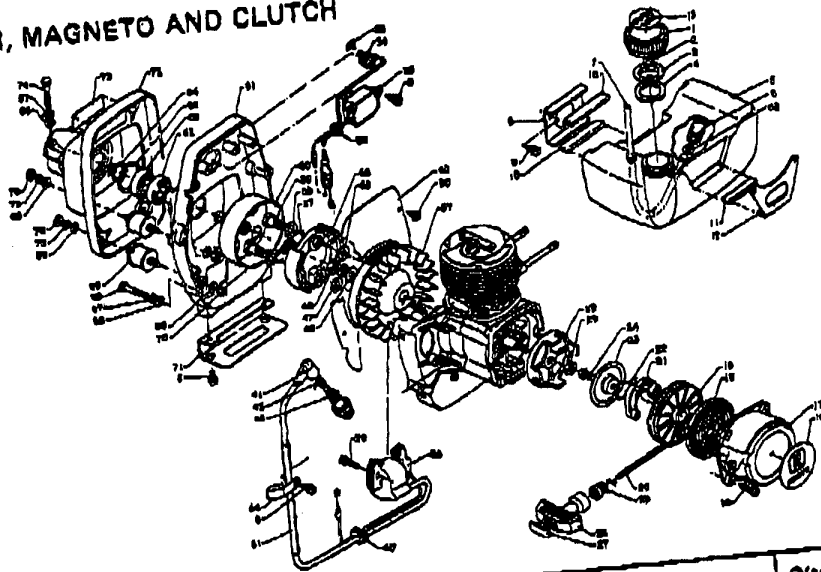

Key No.	Part No.	Q'ty	Description	Key No.	Part No.	Q'ty	Description
2-4	USE 15100409360 <del>101 004-0823 0</del>	1	Cap ass'y, fuel tank	240	152 110-0823 0	1	Rubber grommet, H.T. cord
1	-121 017-0533 0	1	Cap, fuel tank	41	159 012-0192 0	1	Cap, spark plug
2	-131 314-0033 0	1	Check valve	42	159 011-0051 0	1	Coil spring, spark plug cap
3	-131 015-0333 1	1	Holder, check valve	43	159 010-0033 0	1	Spark plug
4	-131 016-0483 0	1	Gasket, fuel tank cap	44	159 113-0823 1	1	Clamp
5	131 010-0823 0	1	Fuel tank	46	900 800-0000 8	1	Washer 8
6	131 205-0523 0	1	Fuel strainer	47	900 805-0000 8	1	Spring washer 8
7	132 010-0823 0	1	Fuel pipe	48	900 800-0000 6	1	Nut 6
8	131 910-0823 0	1	Bracket, fuel tank	49	101 634-0823 0	1	Baffle plate
9	900 242-0501 0	7	Screw 5x10 w/W, SW	50	900 242-0400 8	4	Screw 4x8 w/W, SW
10	131 920-0823 0	2	Cushion, fuel tank	51	152 111-0823 0	1	Sleeve
11	131 924-0823 0	1	Cushion, fuel tank	55	175 049-0392 0	2	Washer
12	131 918-0823 0	1	Bracket, fuel tank	56	175 009-0823 2	2	Clutch shoe
13	890 147-1023 0	1	Decal, fuel mix	57	175 018-0823 0	1	Spring, clutch
15	890 053-0046 2	1	Decal, KIORITZ	58	175 048-0392 0	2	Washer
16	900 242-0501 8	4	Screw 5x18 w/W, SW	59	175 046-0823 0	2	Bolt, clutch shoe
17	177 200-0823 0	1	Recoil starter ass'y	60	175 005-0823 0	1	Clutch drum
18	-177 232-0823 0	1	Starter case	61	101 807-0823 1	1	Fan cover
19	-177 220-0022 0	1	Rewind spring	62	900 802-0800 2	2	Ball bearing 6002
20	-177 216-0623 0	1	Recoll drum	63	900 702-0003 2	1	Circclip 32
21	-177 226-0823 0	1	Starter rope	64	900 701-0001 5	1	Circclip 16
22	-177 218-0623 0	1	Ratchet	65	610 805-0823 0	8	Rubber cushion
23	-177 233-0823 0	1	Spring	66	900 100-0803 0	4	Bolt 6x30
24	-177 211-0823 0	1	Friction plate	67	900 805-0000 6	6	Spring washer 6
25	-177 227-0553 0	1	Screw	68	900 800-0000 6	7	Washer 6
26	-177 228-0111 0	1	Rope guide	69	900 800-0000 5	16	Washer 5
27	-177 244-0111 0	1	Starter handle	70	433 020-0083 0	8	Lock nut 5
28	177 210-0823 0	1	Handle cap, recoil	71	305 110-0823 0	1	Bracket, fan cover
29	900 502-0000 8	1	Pawl catcher	72	610 223-0823 0	1	Bracket, driving shaft hous
33	890 157-1113 0	1	Nut 6	73	880 034-0823 0	1	Decal, model name
34	153 400-0823 0	1	Decal	74	900 100-0803 5	2	Bolt 6x35
35	152 601-0879 0	1	Switch	75	900 605-0000 6	8	Spring washer 5
36	152 114-0823 0	1	T.C. Ignition module	76	900 500-0000 5	8	Nut 5
37	152 601-0823 0	1	Rubber grommet, primary cord	78			
38	152 826-0823 0	1	Flywheel				
39	900 242-0502 0	2	Ignition coil				
			Screw 5x20 w/W, SW				

Remarks:  
 \* Consisting of 1 thru 4.  
 \*\* Consisting of 17 thru 27.

### 3) CARBURETOR

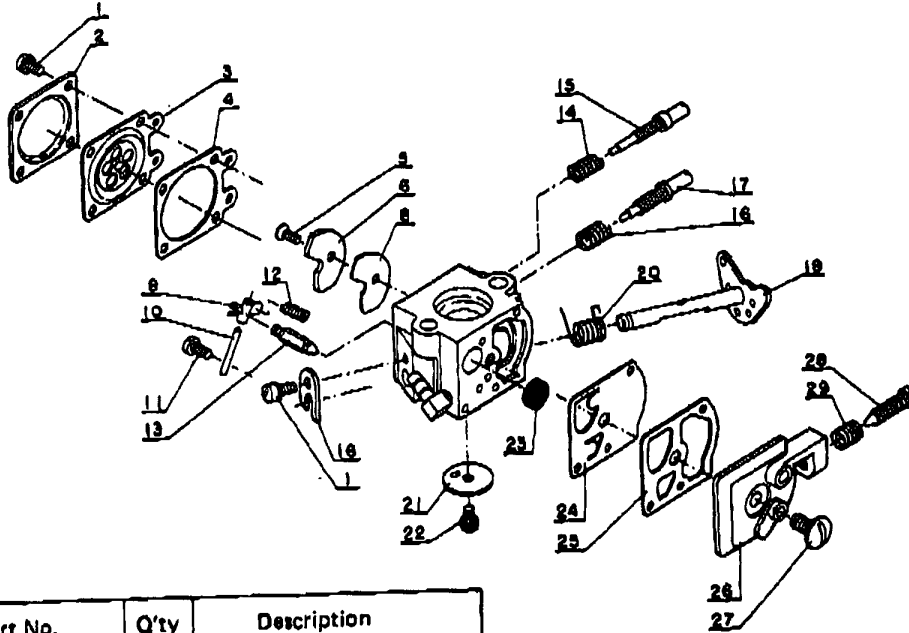

Key No.	Part No.	Q'ty	Description
3. *	123 000-0823 0	1	Carburetor ass'y
1	-123 144-0393 0	5	Screw
2	-123 142-0393 0	1	Cover, metering diaphragm
3	-123 141-0393 0	1	Diaphragm, metering
4	-123 140-0393 0	1	Gasket, metering diaphragm
5	-123 167-0623 0	1	Screw, circuit plate
6	-123 166-1053 0	1	Plate, circuit
8	-123 164-1053 0	1	Gasket, circuit plate
9	-123 123-0393 0	1	Lever, metering
10	-123 138-0393 0	1	Pin, metering lever
11	-123 139-0393 0	1	Screw, metering lever pin
12	-123 122-1123 0	1	Spring, metering lever
13	-123 137-0393 0	1	Valve, inlet needle
14	-123 119-0393 0	1	Spring, H.S. needle
15	-123 120-1123 0	1	Needle, high speed
16	-123 121-0393 0	1	Spring, idle needle
17	-123 118-0623 0	1	Needle, idle
18	-123 127-0393 0	1	Clip, throttle shaft
19	-123 117-1123 0	1	Shaft ass'y, throttle
20	-123 113-0393 0	1	Spring, throttle return
21	-123 116-0393 0	1	Valve, throttle
22	-123 114-0393 0	1	Screw, throttle valve
23	-123 128-0393 0	1	Screen, inlet
24	-123 112-0393 0	1	Diaphragm, fuel pump
25	-123 125-0393 0	1	Gasket, fuel pump
26	-123 124-0823 0	1	Cover, fuel pump
27	-123 110-0393 0	1	Screw, pump cover
28	-123 134-1113 0	1	Screw, idle adjustment
29	-123 133-1113 0	1	Spring, idle screw
30	-Not available	1	Body ass'y, carburetor

Remarks:

\* Consisting of 1 thru 30 except 7.

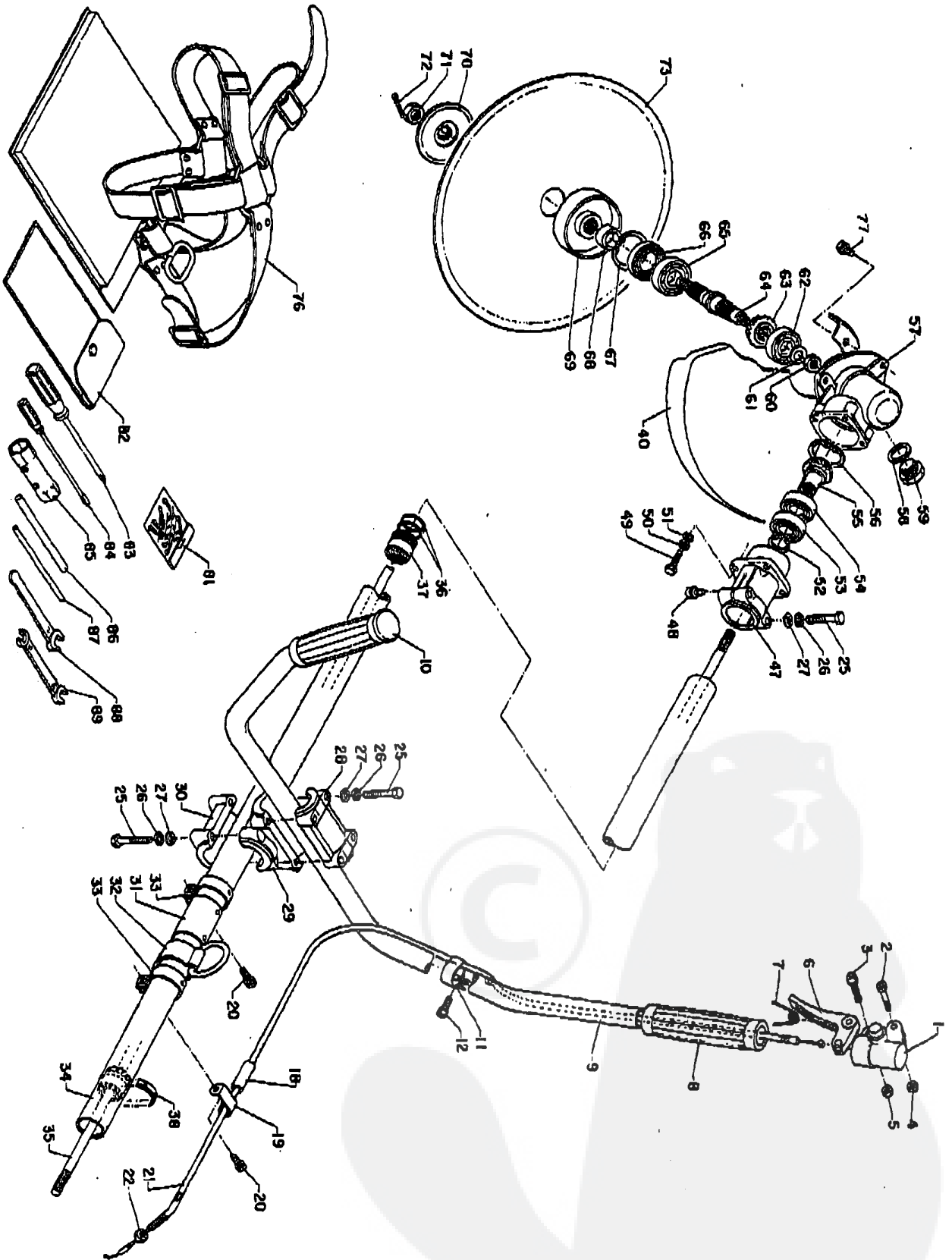

(4) DRIVING SHAFT, CUTTER HEAD AND TOOLS

Key No.	Part No.	Q'ty	Description	Key No.	Part No.	Q'ty	Description
4. 1	178 003-0533 0	1	Bracket, throttle trigger	4.48	-900 242-0501 2	1	Screw 5x12 w/W, SW
2	178 110-0533 0	1	Screw	49	-900 100-0502 0	4	Bolt 5x20
3	900 240-0502 5	1	Screw 5x25 w/w	50	-900 605-0000 5	4	Spring washer 5
4	433 020-0083 0	1	Lock nut 5	51	-900 600-0000 5	4	Washer 5
5	900 500-0000 5	1	Nut 5	52	-900 701-0001 5	1	Circlip 15
6	178 010-0533 0	1	Throttle trigger	53	-800 801-0800 2	1	Ball bearing 8002
7	178 043-0523 0	1	Spring, throttle return	54	-800 800-0800 2	1	Ball bearing 8002
9*	351 300-0623 0	1	Handle	55, 63	-810 300-0623 1	1	Gear set
8	-351 315-0423 0	1	Grip	56	-900 702-0003 2	1	Circlip 32
10	-351 311-0233 0	1	Grip	57	-810 410-0623 1	1	Housing, gear
11	178 106-0533 0	1	Clamp	58	-810 511-0123 0	1	Gasket
12	900 242-0501 2	1	Screw 5x12 w/SW	59	-810 510-0193 0	1	Plug
18	178 127-0493 0	1	Sleeve	60	-900 502-0000 8	1	Nut 8
19	178 111-0823 0	1	Clamp	61	-900 600-0000 8	1	Washer 8
20	900 241-0501 4	2	Screw 6x14 w/SW	62	-900 810-0620 1	1	Ball bearing 6201
21	178 001-0623 0	1	Throttle cable	64	-810 310-0623 1	1	Shaft, P.T.O.
22	900 502-0000 6	1	Nut 6	65	-900 810-0620 2	1	Ball bearing 6202
*	351 301-0623 0	1	Handle bracket ass'y	66	-810 413-0623 0	1	Oil seal
25	-900 100-0603 5	8	Bolt 6x35	67	-900 702-0003 5	1	Circlip 35
26	-900 605-0000 8	8	Spring washer 6	68	-810 334-0623 0	1	Spacer
27	-900 600-0000 8	8	Washer 8	69	-810 313-0623 0	1	Plate, blade fixing
28	-351 312-0623 0	1	Handle bracket, upper	70	-810 314-0623 1	1	Plate, blade fixing
29	-351 313-0623 0	1	Body, handle bracket	71	-900 511-0001 0	1	Nut 10-L.H.
30	-351 314-0623 0	1	Handle bracket, lower	72	-900 300-2002 2	1	Split pin 2x22
31	301 224-0623 0	1	Collar	73	895 001-0123 0	1	Circuta saw (Option)
32	301 210-0623 0	1	Swivel hook	173	898 010-0113 1	1	Eight cutter blade (Option)
33	301 207-0583 0	2	Clamp	76	301 000-0623 1	1	Shoulder band ass'y
34*	810 206-0423 1	1	Housing, driving shaft	77	900 242-0501 4	3	Screw 6x14
36	-810 112-0423 0	10	O-ring	81	898 502-0113 0	1	Split pin 2x22 w/pouch
37	-810 105-0423 0	5	Bush	****	806 000-0623 0	1	Tools set
35	810 011-0623 0	1	Shaft, driving	82	-898 510-0283 0	1	Tool bag
38	890 152-0493 0	1	Label	83	-895 710-0043 0	1	Plus screw driver
40	889 010-0623 0	1	Shield	84	-895 811-0013 0	1	Screw driver 125
				85	-895 419-0533 0	1	Box wrench 17x19
				86	-895 412-0023 0	1	Handle rod
				87	-897 518-0113 0	1	Locking rod
				88	-895 013-0263 0	1	Spanner
				89	-895 112-0033 0	1	Spanner
***	610 400-0623 1	1	Gear housing ass'y	<b>Remarks:</b> * Consists of 25 thru 30. *** Consists of 25 thru 72 except 28 thru 46. **** Consists of 82 thru 89. 9* Include 8 and 10. 34* Include 36 and 37.			
25	-900 100-0603 5	2	Bolt 6x35				
26	-900 605-0000 6	2	Spring washer 6				
27	-900 600-0000 6	2	Washer 6				
47	-810 412-0623 0	1	Housing, bearing				