

CS-302

FROM KLORITZ CORPORATION

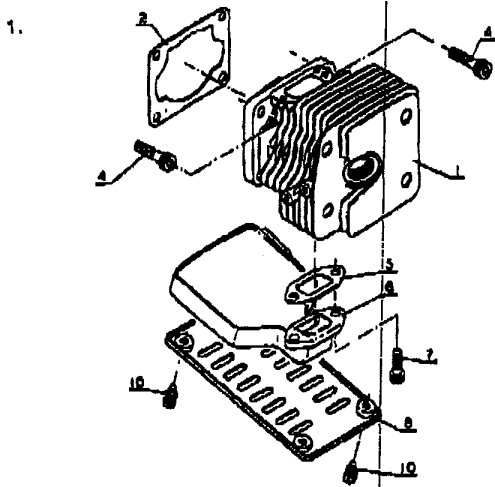

2.

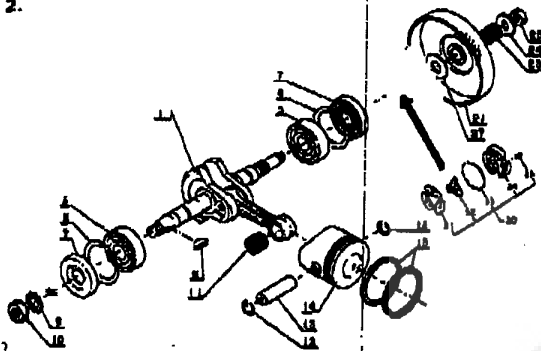

1-1 Spark arrester muffer (Option)

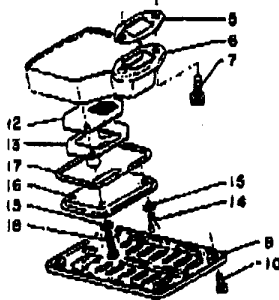

CS502

6月22日(木)14:31/頁14:31/文書番号212320228 P 1

Key No.	Part No.	Q'ty	Description
1- 1	101 011-0393 0	1	Cylinder
2	101 010-0393 1	1	Gasket
4	900 162-0802 0	4	M.S.M. Bolt 5x20
6	145 510-0393 1	1	Muffer gasket
8	145 810-0393 1	1	Muffer
7	900 105-0501 5	2	M.S.M. Bolt 5x15
8	145 821-0393 0	1	Muffer cover
10	900 241-0401 0	4	Screw 4x10

Key No.	Part No.	Q'ty	Description
2- 1	100 100-0393 0	1	Crankshaft ass'y
5	900 810-3620 1	2	Ball bearing 8201
6	900 702-0003 2	2	Circlip 32
7	100 213-0393 0	2	Oil seal
8	100 191-0162 0	1	Key
9	900 811-0000 8	1	Lockwasher 8
10	900 500-0000 8	1	Nut 8
11	100 012-1613 1	1	Roller bearing
12	100 015-0393 0	2	Circlip
13	100 013-0393 0	1	Piston pin
14	100 010-0393 0	1	Piston
16	100 011-0031 0	2	Piston ring
21	175 007-0393 0	1	Clutch case 1/2 DISC
21	175 005-1153 0	1	Clutch case 3/8 91s
23	175 012-0393 0	1	Roller bearing
24	175 014-0393 0	1	Clutch washer 1/2
24	175 014-1153 0	1	Washer 3/8 91s
25	100 198-0393 0	1	Lock nut (84 L-h)
27	175 015-0393 0	1	Clutch washer (in.)
30	175 000-0393 1	1	Clutch ass'y
31	-175 019-1993 0	3	Side plate
32	-175 016-0393 1	1	Beas, clutch
33	-175 018-1993 0	1	Spring
34	-175 002-1993 0	1set	Shoe
35	-900 281-0400 8	8	Screw

Key No.	Part No.	Q'ty	Description
1- 8	145 806-0393 2	1	Muffer
12	145 882-0393 0	1	Screen
13	145 809-0393 0	1	Screen retainer
14	900 220-0400 8	2	Screw 4x8
15	900 810-0000 4	4	Lock washer
18	145 881-0393 1	1	Muffer lid
17	145 888-0393 1	1	Packing
18	900 220-0401 4	2	Screw

3.

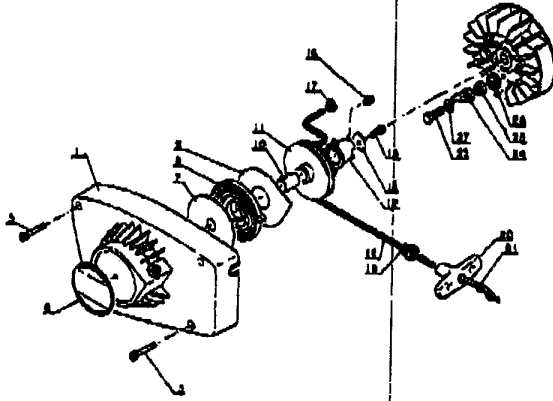

Key No.	Part No.	Q'ty	Description
3-	177 200-0393 0	1	Starter ass'y
1	-101 907-0393 0	1	Fan cover
7	-177 221-0393 0	1	Side plate (A)
8	-177 220-0393 0	1	Spring rawind
9	-177 242-0393 0	1	Side plate (B)
10	-177 218-0393 0	1	Bushing
11	-177 215-0393 0	1	Recoil drum
12	-177 243-0393 0	1	Pawl catcher
13	-177 214-0393 0	1	Washer
15	-800 242-0401 2	1	Screw 4x12
16	-900 241-0400 8	2	Screw 4x8
17	-177 248-0393 0	1	Rope clip
18	-177 228-0393 0	1	Starter rope
19	-177 227-0023 0	1	Rope guide
20	-177 228-1233 0	1	Recoil handle
21	-177 229-1433 0	1	Washer
5	800 182-0403 0	4	M.S.H. Bolt 4x30
6	890 012-1113 2	1	Decal
23	800 100-0801 8	2	Bolt 5x18
24	177 218-0393 0	2	Ratchet
25	177 247-0393 2	2	Spacer
26	177 234-0393 1	2	Ratchet spring
27	900 800-0000 5	2	Washer 5

4.

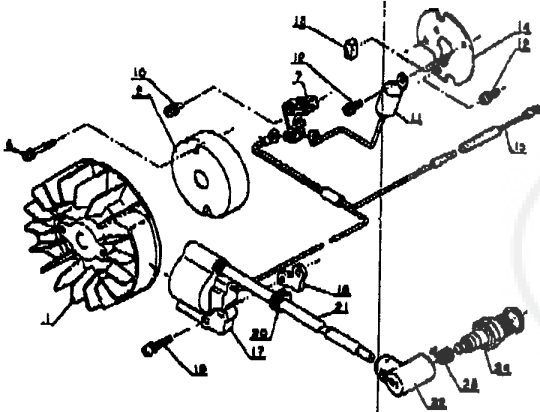

Key No.	Part No.	Q'ty	Description
4-	160 000-0393 1	1	Magneto ass'y
1	-180 200-0393 1	1	Flywheel
2	-188 112-0393 0	1	Breaker cover
8	-800 243-0302 2	2	Screw 3x22
17	-160 128-0393 0	1	Ignition coil
21	-160 111-0393 0	1	Tube, ignition cord
7	-160 101-0393 0	1	Contact points set
10	-900 242-0400 8	1	Screw 4x8
11	-160 127-0393 0	1	Condenser
12	-800 241-0401 2	2	Screw 4x12
13	-160 134-0393 0	1	Oiler
14	-160 132-0393 0	1	Stator plate
16	160 131-0393 0	1	Stop lead cord
18	160 117-0393 0	1	Spacer
18	159 314-1233 0	2	Screw
20	160 110-0393 0	1	Rubber bush
22	169 012-0343 3	1	Spark plug cap
23	169 011-0343 2	1	Spark plug connector
24	169 010-0039 0	1	Spark plug BM6A
24	159 017-1013 0	1	Spark plug RCJBY

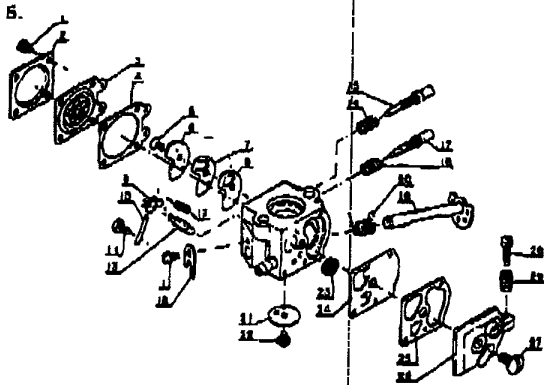

Key No.	Part No.	Q'ty	Description
B-	123 000-0393 1	1	Carburetor ass'y WA5B
1	-123 130-0299 0	5	Screw
2	-123 142-0393 0	1	Metering diaphragm cover
3	-123 141-0393 0	1	Metering diaphragm
4	-123 140-0393 0	1	Diaphragm gasket
5	-123 187-0823 0	1	Circuit plate Screw
6	-123 166-0393 0	1	Circuit plate
7	-123 185-0393 0	1	Check valve diaphragm
8	-123 184-0393 0	1	Circuit plate
9	-123 123-0393 0	1	Metering lever

Key No.	Part No.	Q'ty	Description
6-10	-123 138-0393 0	1	Metering lever pin
11	-123 136-0393 0	1	Lever pin screw
12	-123 122-1113 0	1	Metering lever Spring
13	-123 137-0393 0	1	Inlet needle valve
14	-123 119-0393 0	1	H.S. adjust spring
15	-123 120-1003 0	1	High speed needle
16	-123 121-0393 0	1	Idle needle adjust spring
17	-123 118-0623 0	1	Idle needle
18	-123 127-0393 0	1	Throttle shaft clip
19	-123 117-0393 0	1	Throttle shaft
20	-123 113-0393 0	1	Throttle return spring
21	-123 116-0393 0	1	Throttle valve
22	-123 114-0393 0	1	Shutter screw
23	-123 126-0393 0	1	Inlet screen
24	-123 112-0393 0	1	Pump diaphragm
26	-123 125-0393 0	1	Pump gasket
25	-123 124-0393 0	1	Pump cover
27	-123 110-0393 0	1	Pump cover screw
28	-123 134-0393 0	1	Idle adjust screw
29	-123 133-0393 0	1	Idle adjust spring

Part No.	Description	Key No.
123 103-0393 0	Kit, gasket/diaphragm	3,4,7,8,24,25
123 102-0393 0	Kit, kwik repair	3,4,5,7,8,9,10,12,13,22,23,24,26,32

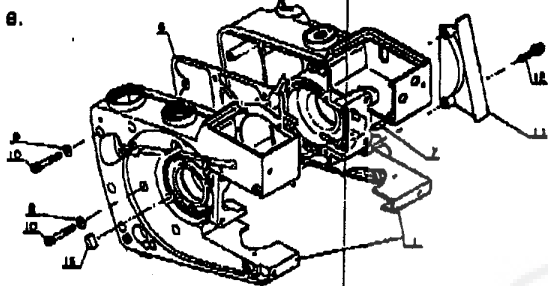

Key No.	Part No.	Q'ty	Description
B-1	100 200-0393 1	1	Crankcase set
7	-100 215-0393 0	2	Knock pin
8	100 242-0393 0	1	Gasket
8	800 800-0000 4	14	Washer 4
10	800 105-0402 6	12	H.S.H. Bolt 4x26
11	100 818-0393 0	1	Dust seal
12	800 243-0402 0	2	Screw 4x20
16	100 814-0393 0	1	Plug

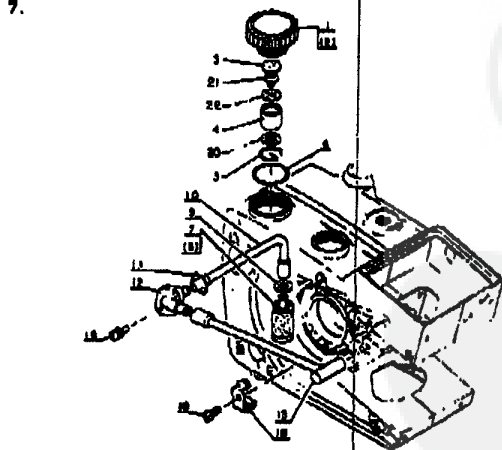

Key No.	Part No.	Q'ty	Description
7-1	131 800-0393 2	1	Cap ass'y, Fuel tank
3	-131 031-0393 0	1	Spacer
4	-131 030-0393 0	1	Supporter
5	-131 032-0393 0	1	Circclip
20	-131 035-0343 1	1	Filter
21	-131 314-0033 0	1	Check valve
22	-131 015-0343 0	1	Check valve holder
2	-890 154-1813 0	1	Label, fuel mix
8	-900 720-0002 2	1	O-ring 22
7	131 200-0283 0	1	Fuel strainer
8	-131 214-0283 0	1	Cap, strainer
9	800 803-0000 5	1	Washer 8
10	132 010-0393 0	1	Fuel pipe (inner) ~
11	800 720-0001 4	1	O-ring 14
12	132 011-0393 0	1	Fuel pipe connector
13	132 012-0393 0	1	Fuel pipe (Outer) ~
16	800 242-0401 2	2	Screw 4x12
18	800 241-0401 0	1	Screw 4x10
19	189 112-0393 0	1	Clip

FROM KIORITZ CORPORATION

2003年 5月22日(木) 14:31 / 印刷: 14:31 / 文書番号: 6212320228 P 4

8.

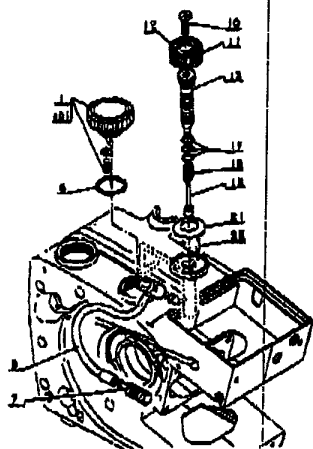

Key No.	Part No.	Q'ty	Description
8- 1	438 002-1143 1	1	Cap ass'y (oil tank)
2	-890 153-1143 0	1	Desal. chain oil
6	-900 720-0001 8	1	O-ring 18
7	438 205-0283 2	1	Oil strainer
8	437 211-0393 2	1	Oil pipe (inner) <i>Disc.</i>
10	900 220-0501 4	1	Screw 5x14
11	437 038-0343 0	1	Dial
12	890 022-0343 0	1	Caution label
13, 18	437 000-0343 0	1	Auto. Ciler ass'y
17	-437 020-0283 0	3	O-ring (S-5)
19	-437 018-0283 0	1	Spring
21	437 038-0343 0	1	Flat spring
22	900 330-1509 8	1	Needle roller

9.

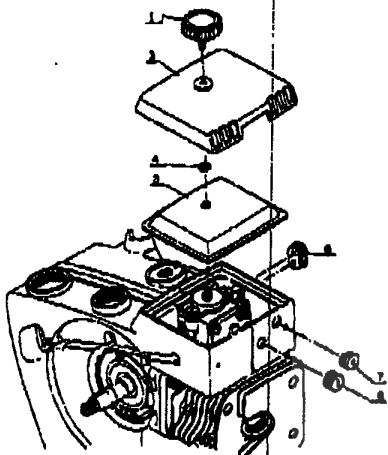

Key No.	Part No.	Q'ty	Description
8- 1	130 408-0393 0	1	Thumb bolt
3	130 313-0393 0	1	Cover
4	800 700-0000 3	1	E-ring 3
5	130 310-0393 0	1	Air filter
6	128 010-0393 0	1	Grommet
7	178 810-0393 0	1	Grommet
8	178 210-0023 0	1	Grommet

10.

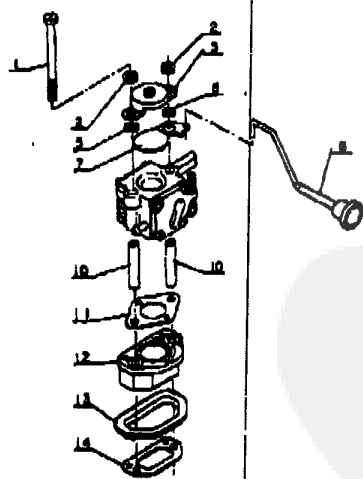

Key No.	Part No.	Q'ty	Description
10- 1	130 021-0393 0	2	Bolt, carb.
2	180 028-0393 0	2	Washer, carb.
3	130 408-0393 0	1	Cleaner set plate
5	178 518-0393 0	2	Washer
7	178 515-0393 0	1	Choke shutter
8	178 510-0393 2	1	Choke rod
10	130 019-0393 0	2	Spacer
11	130 018-0393 2	1	Gasket (B)
12	130 017-0393 1	1	Insulator
13	130 012-0393 0	1	Dust seal, carb.
14	130 010-0393 2	1	Gasket (A)

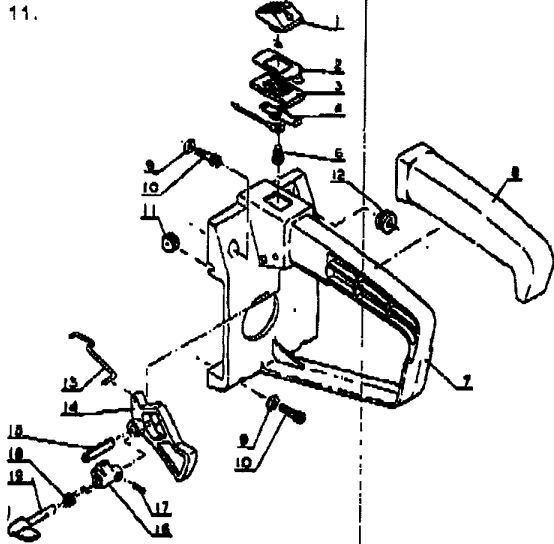

Key No.	Part No.	Q'ty	Description
11- 1	183 410-0283 0	1	Body, switch
2	183 413-0283 0	1	Ground plate
3	183 411-0283 0	1	Guide switch
4	183 412-0083 0	1	Spring switch
5	900 241-0401 0	1	Screw 4x10
7	351 010-0383 0	1	Rear handle
8	351 012-0383 0	1	Grip
9	800 800-0000 4	4	Washer 4
10	900 108-0401 8	4	H.S.H. Bolt 4x18
11	150 114-0383 0	1	Grommet
12	178 810-0383 0	1	Grommet
13	178 011-0383 0	1	Throttle connecting rod
14	178 010-0383 0	1	Throttle trigger
15	900 340-5002 5	1	Spring pin
16	178 012-0383 0	1	Throttle latch
17	900 340-1601 0	1	Spring pin 1.6 mm
18	178 013-0383 0	1	Throttle spring
18	178 008-0343 0	1	Lock lever

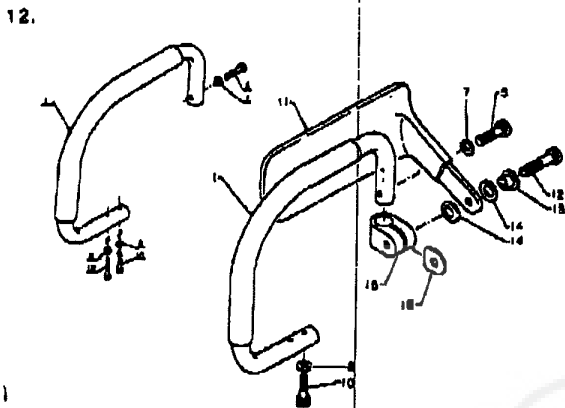

Key No.	Part No.	Q'ty	Description
12- 1	351 205-0383 1	1	Front handle
5	900 105-0602 0	1	H.S.H. Bolt 5x20
7	100 247-0283 0	1	Washer
8	800 800-0000 4	2	Washer 4
10	900 105-0401 8	2	H.S.H. Bolt 4x18
Hand guard type			
1	351 205-0383 1	1	Front handle
5	900 105-0602 0	1	H.S.H. bolt 5 x 20
7	100 247-0283 0	1	Washer
8	800 800-0000 4	2	Washer 4
10	900 105-0401 8	2	H.S.H. bolt 4 x 18
11	351 800-1333 1	1	Hand guard ass'y
12	-351 805-1333 1	1	Hand guard
13	-900 182-0503 0	1	H.S.H. bolt 5 x 30
13	-351 827-1333 0	1	Spacer
14	-351 838-1333 0	2	Conical spring washer
15	-351 835-1333 0	1	Holder
16	-351 841-1333 0	1	Spacer

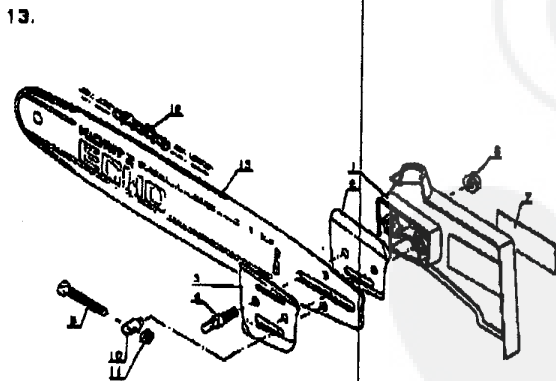

Key No.	Part No.	Q'ty	Description
13- 1	433 010-0383 1	1	Guide bar cover
2	433 012-0383 0	1	Side plate (outer)
3	433 013-0383 0	1	Side plate (inner)
4	433 011-0383 1	2	Stud
6	433 019-0383 3	2	Flange nut
7	880 021-0383 1	1	Decal
8	433 016-0283 0	1	Adjusting screw
10	433 014-0383 2	1	Tensioner
11	433 022-0283 0	1	Lock nut

KIORITZ CORPORATION

5-1, SHIMORENJAKU 7-CHOME, MITAKA, TOKYO 181, JAPAN
 PHONE:0422-48-6115 P.O. BOX 10 MITAKA TOKYO
 CABLE ADDRESS:KIORITZ MITAKA TELEX:KIORITZ A J28592

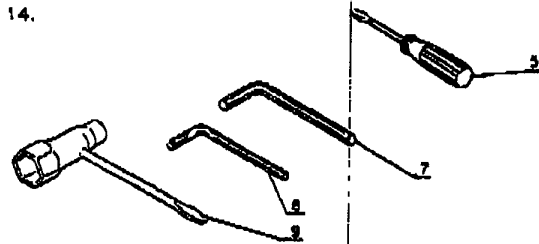

Key No.	Part No.	Q'ty	Description
14- 6	895 812-0383 0	1	Screw-driver (50 mm)
7	895 810-0013 0	1	L-wrench (4 mm)
8	895 812-0343 0	1	L-wrench (5 mm)
9	895 410-0393 0	1	Box wrench, W/driver

15.
 Chain brake (Option)

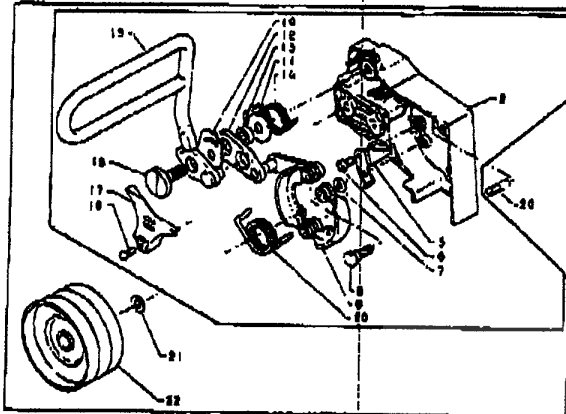

Key No.	Part No.	Q'ty	Description
15.	433 102-0393 2	1	Chain brake kit
20	--433 132-0383 0	1	Knock
21	-175 214-0383 0	1	Washer
22	-175 207-0393 1	1	Clutch case
	-433 100-1333 0	1	Chain brake ass'y
2	--433 110-0293 0	1	Guide bar cover
6	--433 131-0393 0	1	Shoe guide
6	-900 220-0800 8	2	Screw 5x8
7	-900 800-0000 8	1	Washer 8
8	--433 130-0393 0	1	Bolt
9	--433 101-1333 0	1	Brake shoe
10	--433 122-1333 0	1	Spring
11	--433 115-0393 0	1	Washer
12	--433 117-0383 0	1	Connector
13	--433 118-0393 0	1	Spacer
14	--433 114-0383 0	1	Return spring
15	--433 108-0383 2	1	Brake handle
16	--433 113-0383 0	1	Screw
17	--433 310-0393 1	1	Dust seal
18	-900 220-0400 8	1	Screw 4x 8
18	--433 135-1053 0	1	Washer