

Parts List

Group:Chain Saws Model:CS-310ES(37) Section:Cylinder,Crankcase,Piston(1)

Key	Lv	Part Number	Q'ty	Description	Remarks	Note
1		P021-015050	1	CRANK CASE KIT		
2	+	V805-000220	4	BOLT, TORX 5		
3		A202-000070	1	BELLOWS, INTAKE		
4		A206-000000	1	HOLDER, BELLOWS		
5		P021-015060	1	PISTON KIT		
6	+	100011-16131	1	RING, PISTON		
7	+	100013-15330	1	PIN, PISTON		
8	+	100015-04630	2	CIRCLIP, PISTON PIN		
9	+	100113-11520	1	BEARING, NEEDLE		
10	+	100014-11520	2	SPACER, PISTON PIN		
11		100142-12330	1	KEY, WOODRUFF		
12		P021-015070	1	CRANKSHAFT, ASSY		
13	+	V505-000010	2	SEAL, OIL 12		
14	+	94035-36201	2	BEARING BALL		
16		P021-015080	1	COVER, ENGINE		
17	+	V225-000030	2	BOLT, STUD 8		
18		C463-000030	2	KNOB, LATCH		
19		J485-000200	2	HINGE		
20		V490-000400	2	CLIP		
21		93050-40180	4	ROLLER		
22		V805-000180	4	BOLT, TORX 5		

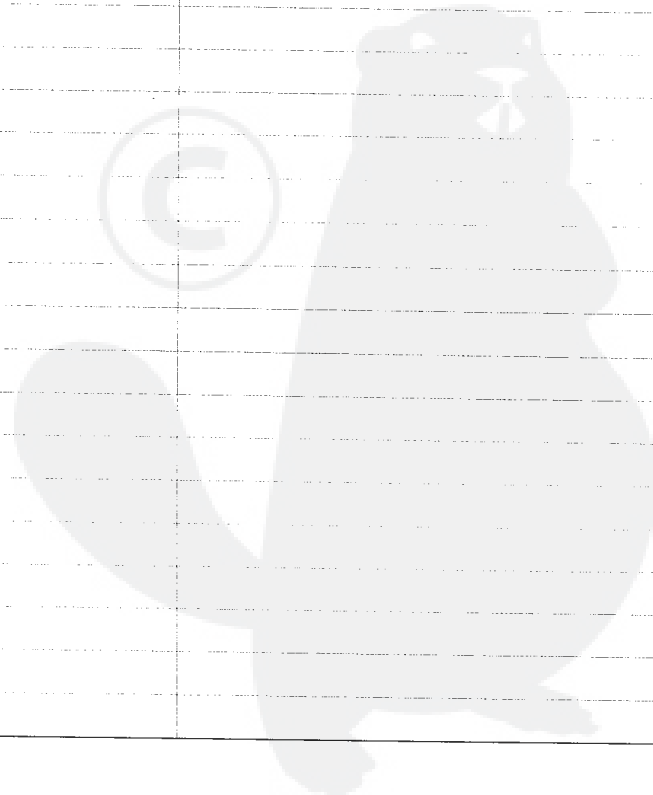

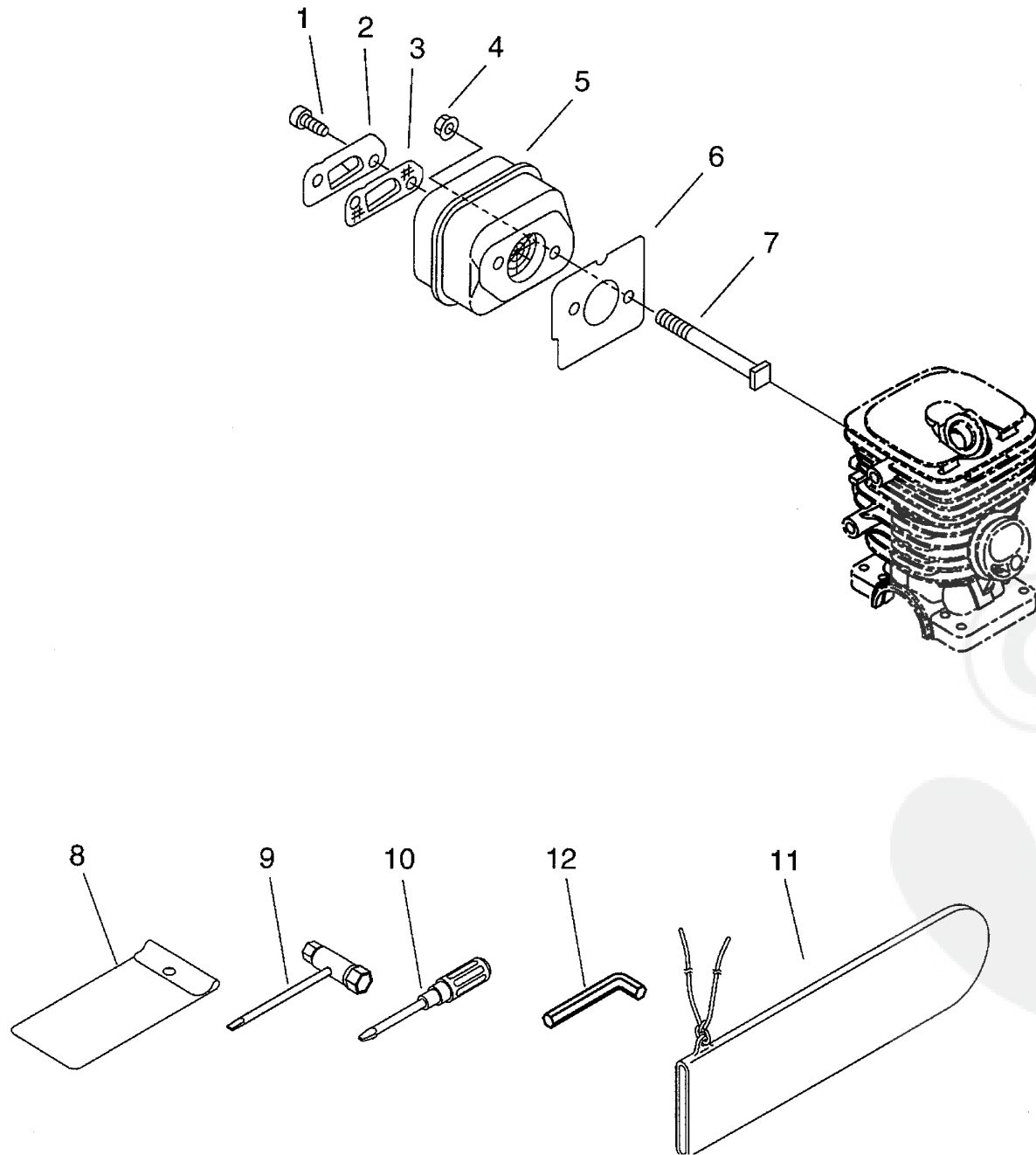

Parts List

Group:Chain Saws Model:CS-310ES(37) Section:Muffler,Tools(2)

Key	Lv	Part Number	Q'ty	Description	Remarks	Note
1		V804-000030	2	BOLT, TORX 4		
2		A313-000760	1	GUIDE, EXHAUST		
3		A310-000060	1	SCREEN, ARRESTOR		
4		900516-00005	2	NUT, FRANGE 5		
5		A300-000620	1	MUFFLER, EXHAUST		
6		V104-000731	1	GASKET, EXHAUST		
7		V203-000120	2	BOLT, 5		
8		898510-07130	1	BAG, TOOL		
9		X602-000080	1	TOOL, WRENCH		
10		895812-03930	1	DRIVER, SCREW 50		
11		P021-006951	1	SCABBARD, CHAIN		
12		X605-000050	1	TOOL, L WRENCH		

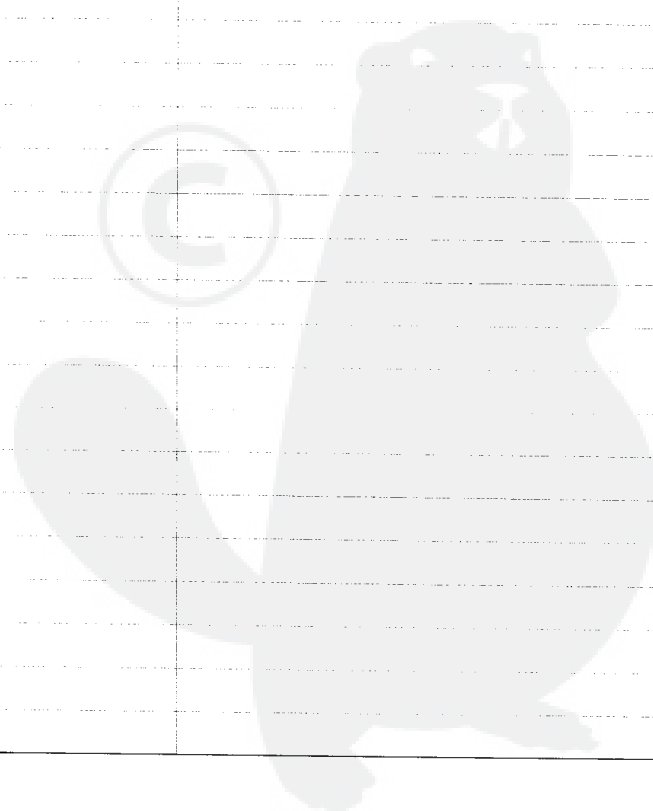

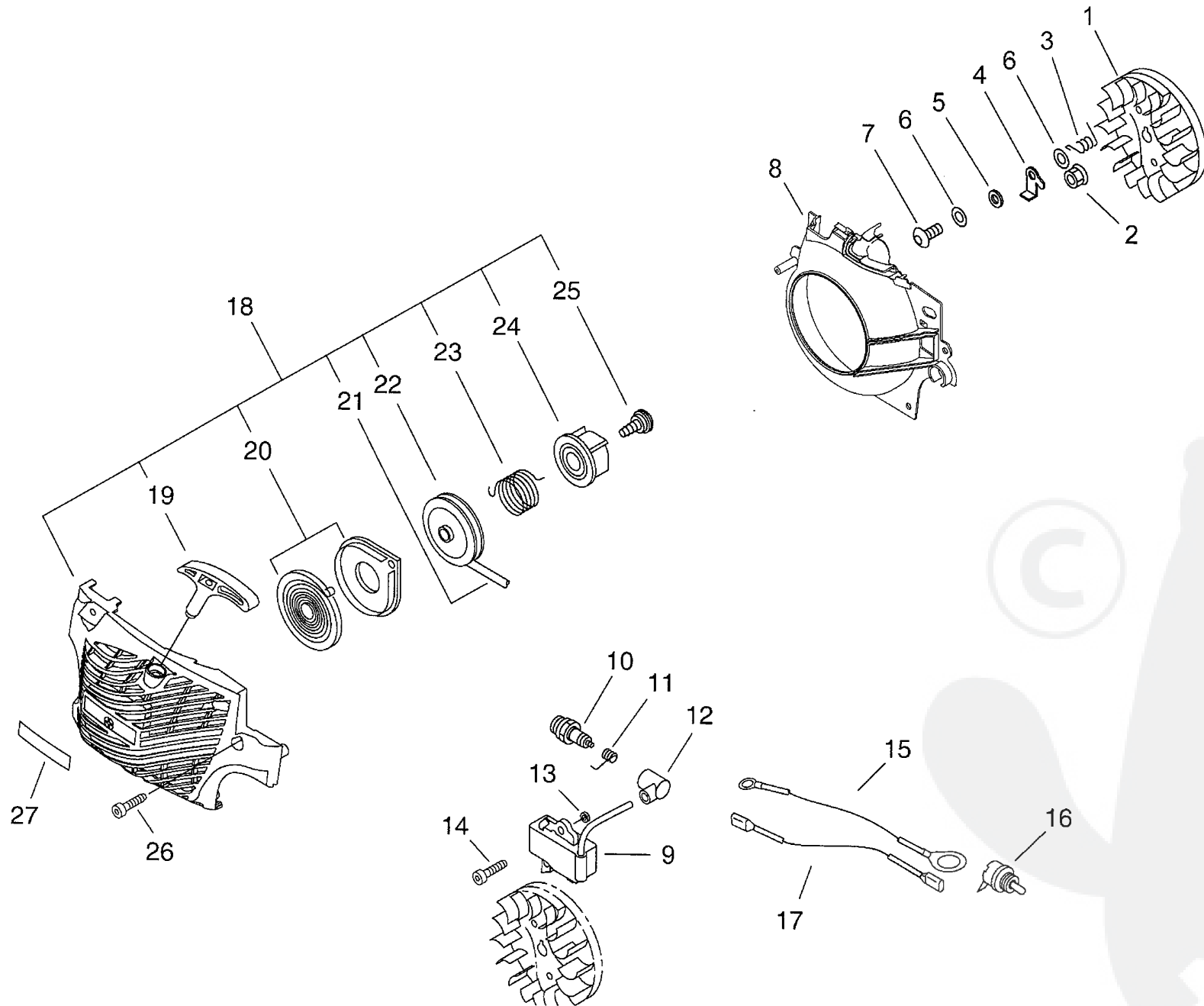

Parts List

Group:Chain Saws Model:CS-310ES(37) Section:Starter,Magneto(3)

Key	Lv	Part Number	Q'ty	Description	Remarks	Note
1		A409-000350	1	ROTOR, MAGNETO		
2		900515-00008	1	NUT, FLANGE 8		
3		177234-35430	2	SPRING, RETURN		
4		A514-000020	2	PAWL		
5		177247-04630	2	SPACER, RATCHET		
6		900603-00005	4	WASHER 5		
7		V203-000080	2	BOLT, 5		
8		A172-000830	1	COVER, FAN		
9		A411-000460	1	COIL, IGNITION		
10		A425-000000	1	SPARKPLUG		
11		A426-000020	1	TERMINAL, SPARKPLUG		
12		A427-000020	1	CAP, SPARK PLUG		
13		150117-16430	2	SPACER		
14		V805-000210	2	BOLT, TORX 5		
15		V485-001070	1	LEAD		
16		A440-001180	1	SWITCH, ON OFF		
17		V485-001080	1	LEAD		
18		A051-001300	1	STARTER, RECOIL ASY		
19	+	P022-005891	1	GRIP, STARTER		
20	+	P022-001330	1	SPRING KIT, REWIND		
21	+	P022-008440	1	ROPE, STARTER		
22	+	A506-000030	1	REEL, ROPE		
23	+	V452-000220	1	SPRING, TORSION		
24	+	P022-022000	1	CATCHER, PAWL		
25	+	177236-61830	1	SCREW		
26		V805-000010	3	BOLT, TORX 5		
27		X502-000340	1	LABEL, ECHO		

P a r t s L i s t

Group:Chain Saws Model:CS-310ES(37) Section:Carburettor,Cylinder cover,Fuel, Oil tank(4)

Key	Lv	Part Number	Q'ty	Description	Remarks	Note
1		P021-005581	1	OIL CAP ASY		
2	+	900720-00018	1	O-RING 18		
3	+	A365-000050	1	CONNECTOR,CAP		
4		436114-13930	1	VALVE, CHECK		
5		436205-02832	1	STRAINER, OIL		
6		132115-01461	1	GROMMET		
7		130110-05260	1	PIPE, IMPULSE		
8		V186-000020	1	JOINT,PIPE		
9		V470-000810	1	PIPE		
10		V137-000000	1	GROMMET, FUEL		
11		A356-000030	1	VALVE,CHECK		
12		131004-37932	1	CAP ASY, FUEL		
13	+	900720-00022	1	O-RING 22		
3	+	A365-000050	1	CONNECTOR,CAP		
15		V471-002170	1	PIPE		
16		132013-09820	1	CLIP		
17		V471-001560	1	PIPE		
18		132115-44330	1	GROMMET		
19		131205-14930	1	STRAINER, FUEL		
20		V805-000010	2	BOLT, TORX 5		
21		A200-000350	1	INSULATOR, INTAKE		
22		A021-001700	1	CARBURETOR,DIAPHRAGM		
23		V805-000040	2	BOLT, TORX 5		
24		A225-000280	1	CASE,CLEANER		
25		V805-000000	1	BOLT, TORX 5		
26		A226-000420	1	ELEMENT, AIR FILTER		
27		123181-39130	1	PUMP, PRIMER		
28		V471-002190	1	PIPE		

Parts List

Group:Chain Saws Model:CS-310ES(37) Section:Carburettor,Cylinder cover,Fuel, Oil tank(4)

Key	Lv	Part Number	Q'ty	Description	Remarks	Note
29		V130-000010	1	GROMMET, CHOKE		
30		A241-000150	1	KNOB, CHOKE		
31		C022-000040	1	AUTO-OILER ASSEMBLY		
32		V420-001790	2	CUSHION		
33		A160-001070	1	COVER, CYLINDER		
34		V341-000110	1	WASHER, SQUARE		
35		V341-000120	1	WASHER, SQUARE		
36		100927-35830	1	PIPE		
37		890157-39130	1	LABEL, SWITCH		
38		X524-001900	1	LABEL		
39		X503-009270	1	LABEL, MODEL		
40		890631-38130	1	LABEL, CAUTION		
41		V582-000050	1	RING, SNAP		
42		V103-000500	1	GASKET, INTAKE		
43		130338-32430	1	PLUG, COVER		
44		890345-39230	1	LABEL, CAUTION		

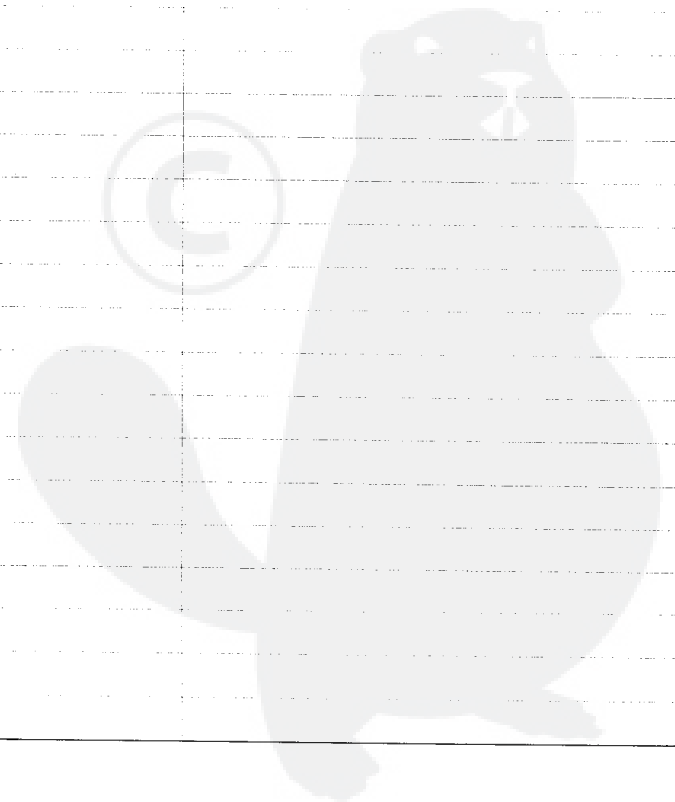

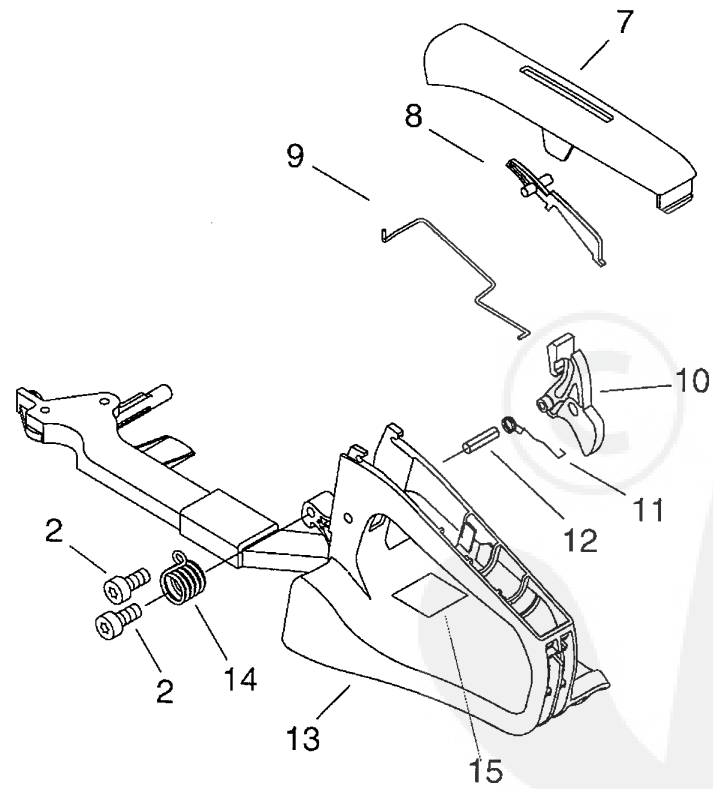
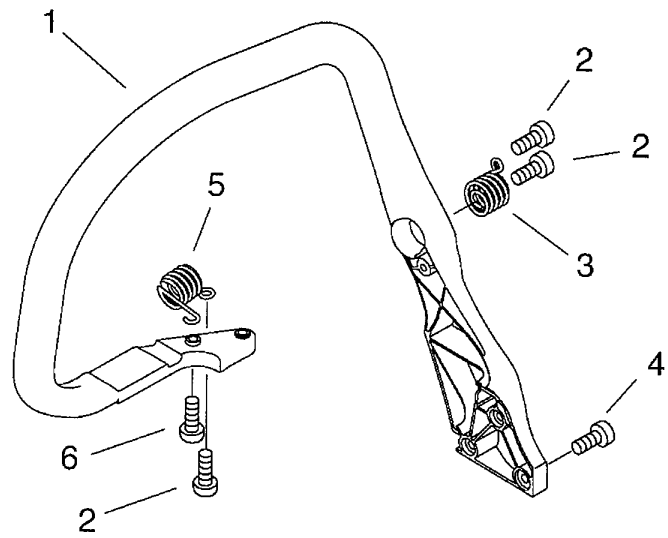

Parts List

Group:Chain Saws Model:CS-310ES(37) Section:Front Handle, Rear Handle(5)

Key	Lv	Part Number	Q'ty	Description	Remarks	Note
1		C400-000540	1	HANDLE, FRONT		
2		V805-000000	5	BOLT, TORX 5		
3		V450-000700	1	SPRING, COMPRESSION		
4		V805-000010	3	BOLT, TORX 5		
5		V450-000710	1	SPRING, COMPRESSION		
6		V805-000000	2	BOLT, TORX 5		
7		C411-000040	1	LID, HANDLE		
8		C460-000072	1	LOCKOUT, THROTTLE		
9		C454-000160	1	ROD, THROTTLE		
10		C450-000212	1	CONTROL, THROTTLE		
11		V452-000260	1	SPRING, TORSION		
12		900345-40025	1	PIN, SPRING 4*25SUS		
13		C410-000450	1	HANDLE, REAR		
14		V450-000720	1	SPRING, COMPRESSION		
15		890345-39230	1	LABEL, CAUTION		

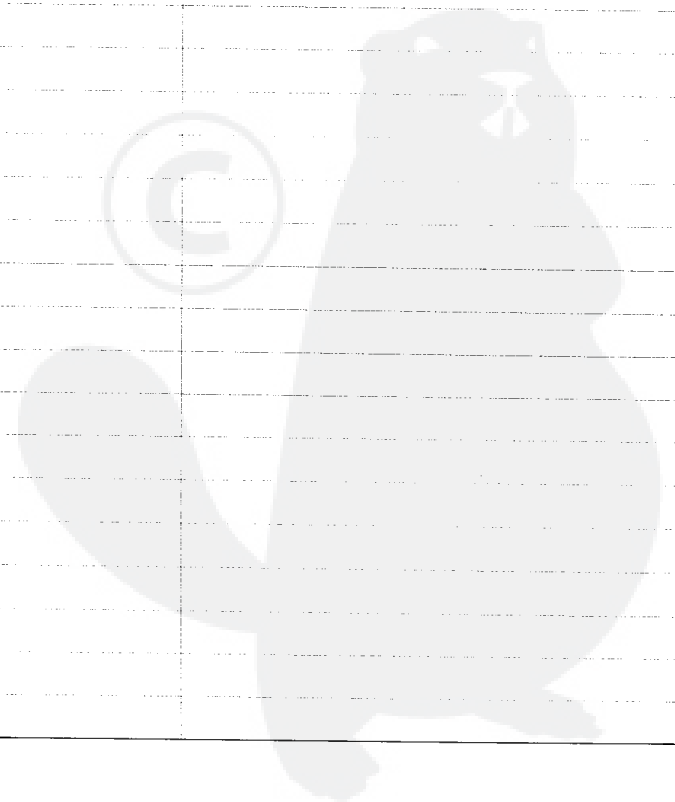

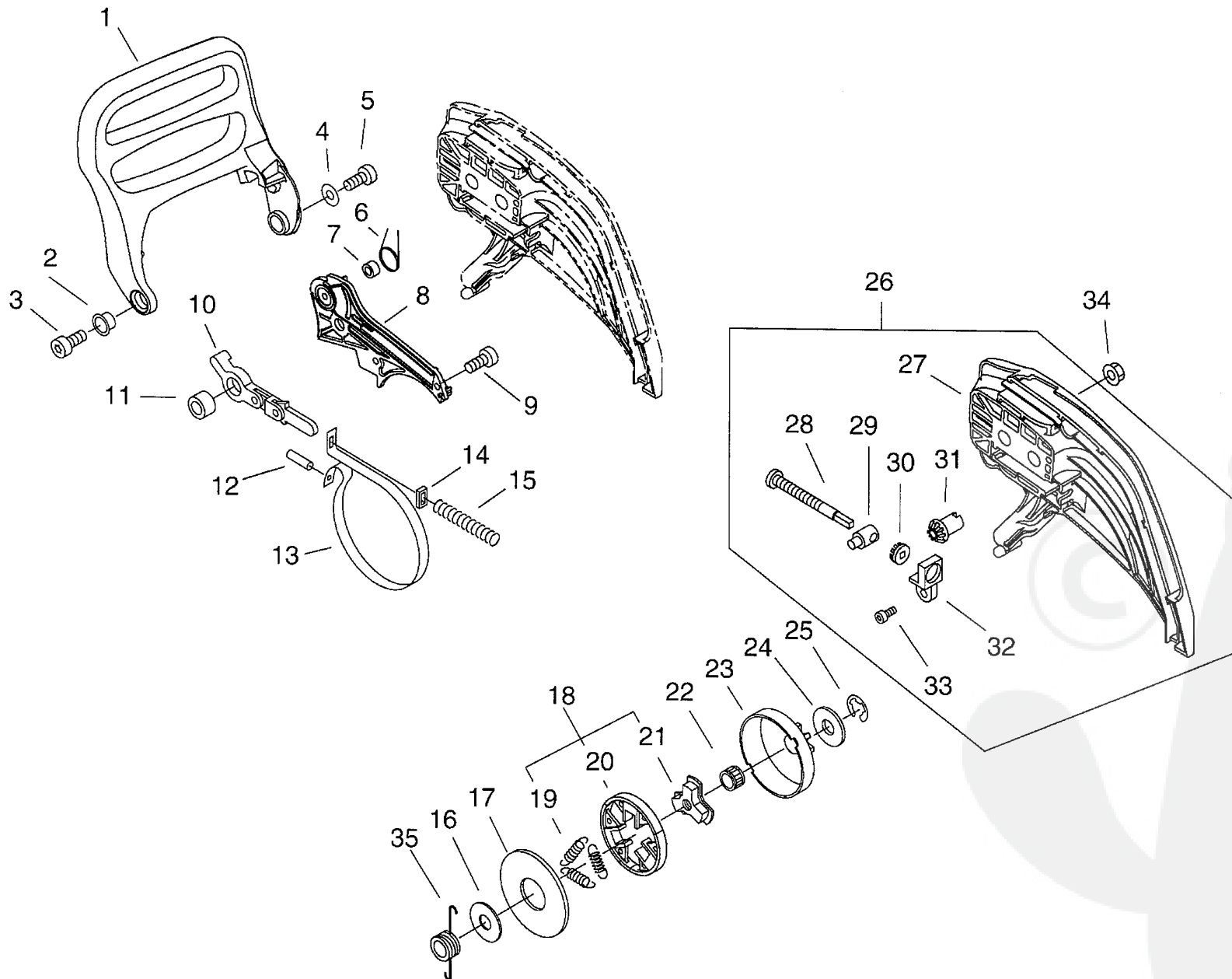

P a r t s L i s t

Group:Chain Saws Model:CS-310ES(37) Section:Clutch,Sprocket,Brake Handle(6)

Key	Lv	Part Number	Q'ty	Description	Remarks	Note
1		C320-000170	1	LEVER, BRAKE		
2		V356-000430	1	COLLAR,10		
3		V805-000010	1	BOLT, TORX 5		
4		177214-03930	1	WASHER		
5		V804-000020	1	BOLT, TORX 4		
6		V452-000250	1	SPRING,TORSION		
7		433116-35430	1	SPACER 8		
8		C345-000270	1	COVER,BRAKE		
9		V804-000000	3	BOLT, TORX 4		
10		C334-000100	1	CONNECTOR, BRAKE		
11		433116-35430	1	SPACER 8		
12		93050-30098	1	ROLLER		
13		C328-000030	1	BAND,BRAKE		
14		V376-000450	1	SPACER		
15		V450-000070	1	SPRING,COMPRESSION		
16		A551-000080	1	PLATE, CLUTCH		
17		A551-000090	1	PLATE, CLUTCH		
18		A056-000210	1	CLUTCH ASY		
19	+	V451-000470	3	SPRING,TENSION		
20	+	A555-000060	3	SHOE,CLUTCH		
21	+	A552-000100	1	HUB, CLUTCH		
22		175012-03930	1	BEARING, NEEDLE		
23		A556-000540	1	DRUM, CLUTCH		
24		100143-19830	1	WASHER		
25		V583-000120	1	RING		
26		P021-015110	1	GUARD, SPROCKET KIT		
27	+	C300-000400	1	GUARD, SPROCKET		
28	+	V203-000110	1	BOLT, 5		

Parts List

Group:Chain Saws Model:CS-310ES(37) Section:Clutch,Sprocket,Brake Handle(6)

Key	Lv	Part Number	Q'ty	Description	Remarks	Note
29	+	C309-000030	1	TENSIONER,CHAIN		
30	+	V651-000011	1	GEAR,BEVEL		
31	+	V651-000001	1	GEAR,BEVEL		
32	+	V355-000140	1	COLLAR,8		
33	+	V804-000000	1	BOLT, TORX 4		
34		433019-12330	2	NUT, FLANGE 8		
35		V652-000040	1	GEAR,WORM		

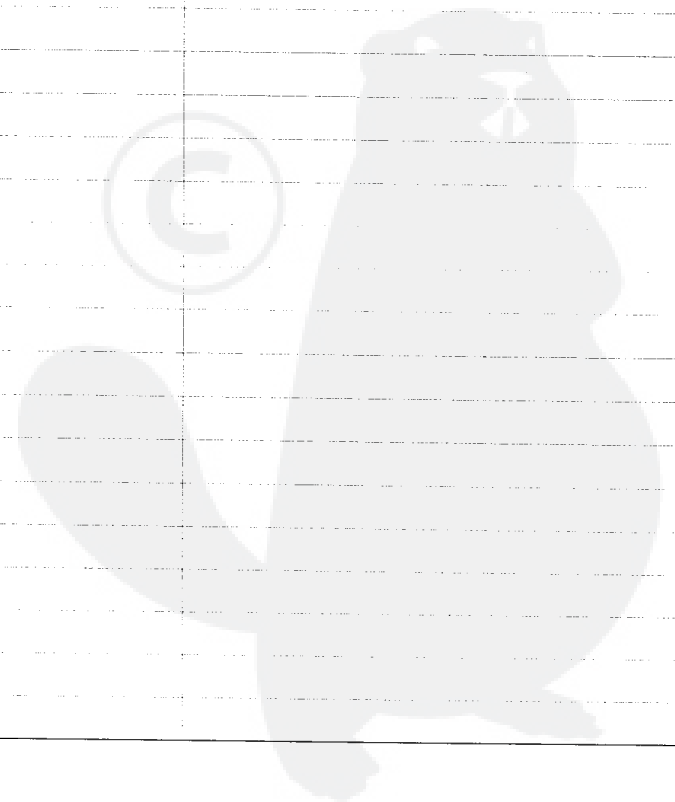

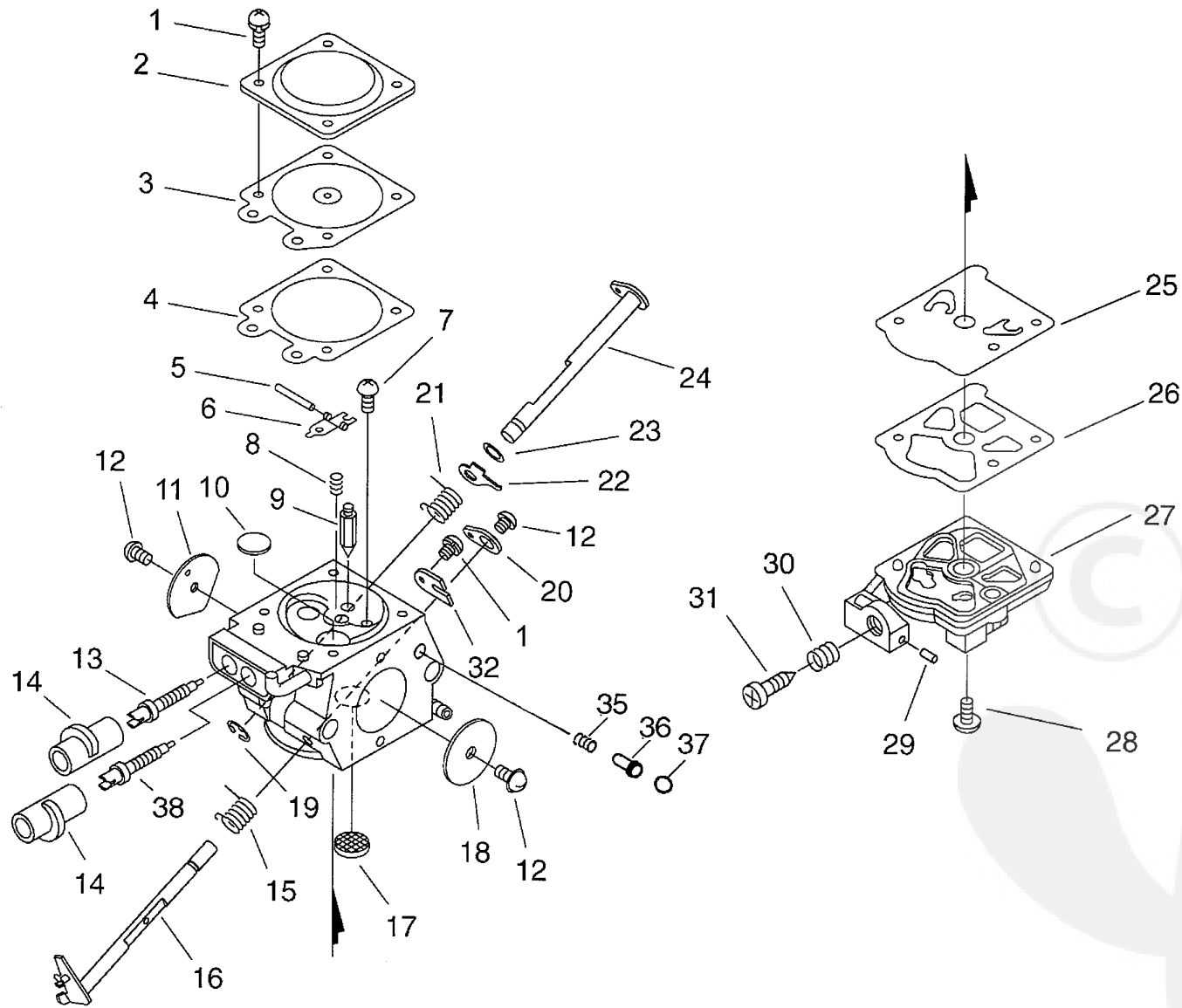

Parts List

Group:Chain Saws Model:CS-310ES(37) Section:Carburettor(7)

Key	Lv	Part Number	Q'ty	Description	Remarks	Note
		A021-001310	1	CARBURETOR, DIAPHRAGM		
1 +		123130-02960	4	SCREW		
2 +		123142-03930	1	COVER, M. DIAPHRAGM		
3 +		P003-001850	1	DIAPHRAGM, METERING		
4 +		123140-03930	1	GASKET, M. DIAPHRAGM		
5 +		123138-03930	1	PIN, METERING LEVER		
6 +		123123-03930	1	LEVER, METERING		
7 +		123139-03930	1	SCREW, M. LEVER PIN		
8 +		123122-39330	1	SPRING, METER. LEVER		
9 +		123137-19830	1	VALVE, INLET NEEDLE		
10 +		123146-10631	1	PLUG, WELCH		
11 +		P003-002250	1	VALVE, CHOKE		
12 +		123114-38830	3	SCREW		
13 +		123120-52131	1	NEEDLE, HIGH SPEED		
38 +		123118-02261	1	NEEDLE		
14 +		P003-000010	2	LIMITER CAP		
15 +		123113-37530	1	SPRING, THROTTLE RTN		
16 +		P003-002240	1	SHAFT ASY, THROTTLE		
17 +		123126-10631	1	SCREEN, INLET		
18 +		123116-05960	1	VALVE, THROTTLE		
19 +		123127-15030	1	RING		
20 +		P003-001040	1	LEVER THROTTLE		
21 +		P003-002260	1	SPRING		
22 +		P003-001510	1	LEVER-FAST IDLE		
23 +		123149-26030	1	WASHER		
24 +		P003-000150	1	CHOKE, SHAFT		
25 +		123112-15030	1	DIAPHRAGM, FUEL PUMP		
26 +		123125-15030	1	GASKET, FUEL PUMP		

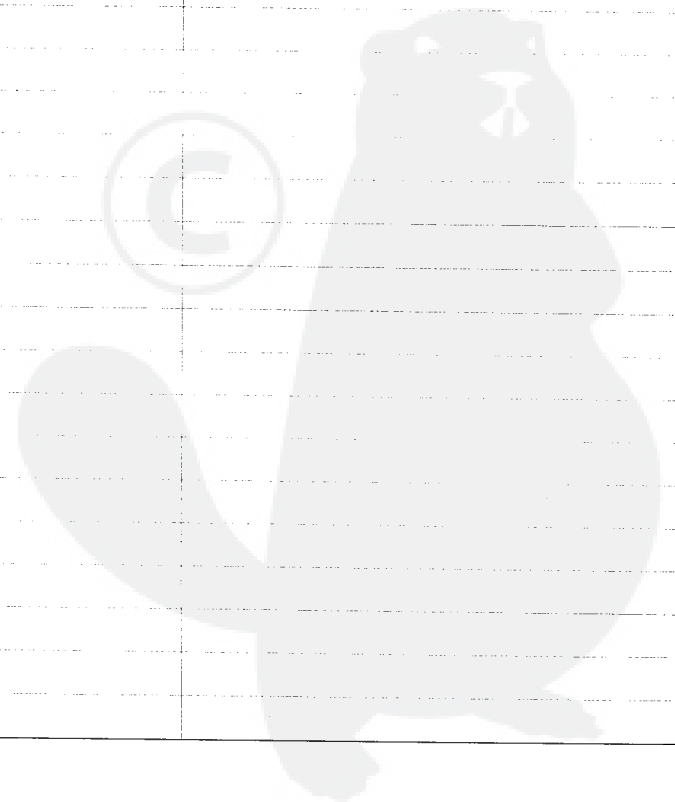

Parts List

Group:Chain Saws Model:CS-310ES(37) Section:Carburettor(7)

Key	Lv	Part Number	Q'ty	Description	Remarks	Note
27	+	123124-09520	1	COVER, FUEL PUMP		
28	+	123110-03930	1	SCREW, PUMP COVER		
30	+	123133-04260	1	SPRING, IDLE ADJUST		
31	+	123134-04260	1	SCREW, IDLE ADJUST		
32	+	123127-03930	1	CLIP, THROTTLE SHAFT		
35	+	123186-09660	1	SPRING, START VALVE		
36	+	123185-09660	1	PISTON ASSY		
37	+	123136-09660	1	BALL		

