

ET

# ECHO

## CHAIN SAW

### OPERATOR'S MANUAL

#### CS-900EVL

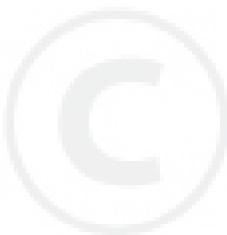
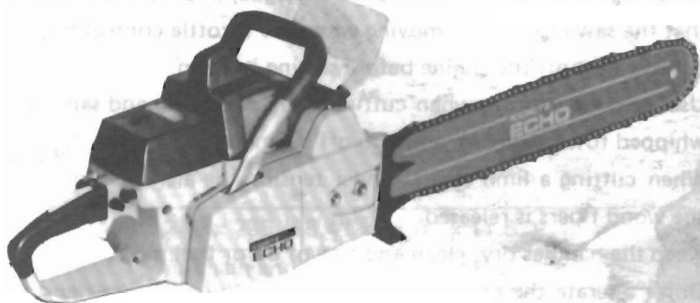

#### **CAUTION**

Read Rules for Safe Operation  
and Instructions Carefully

1

898 571-1473 0

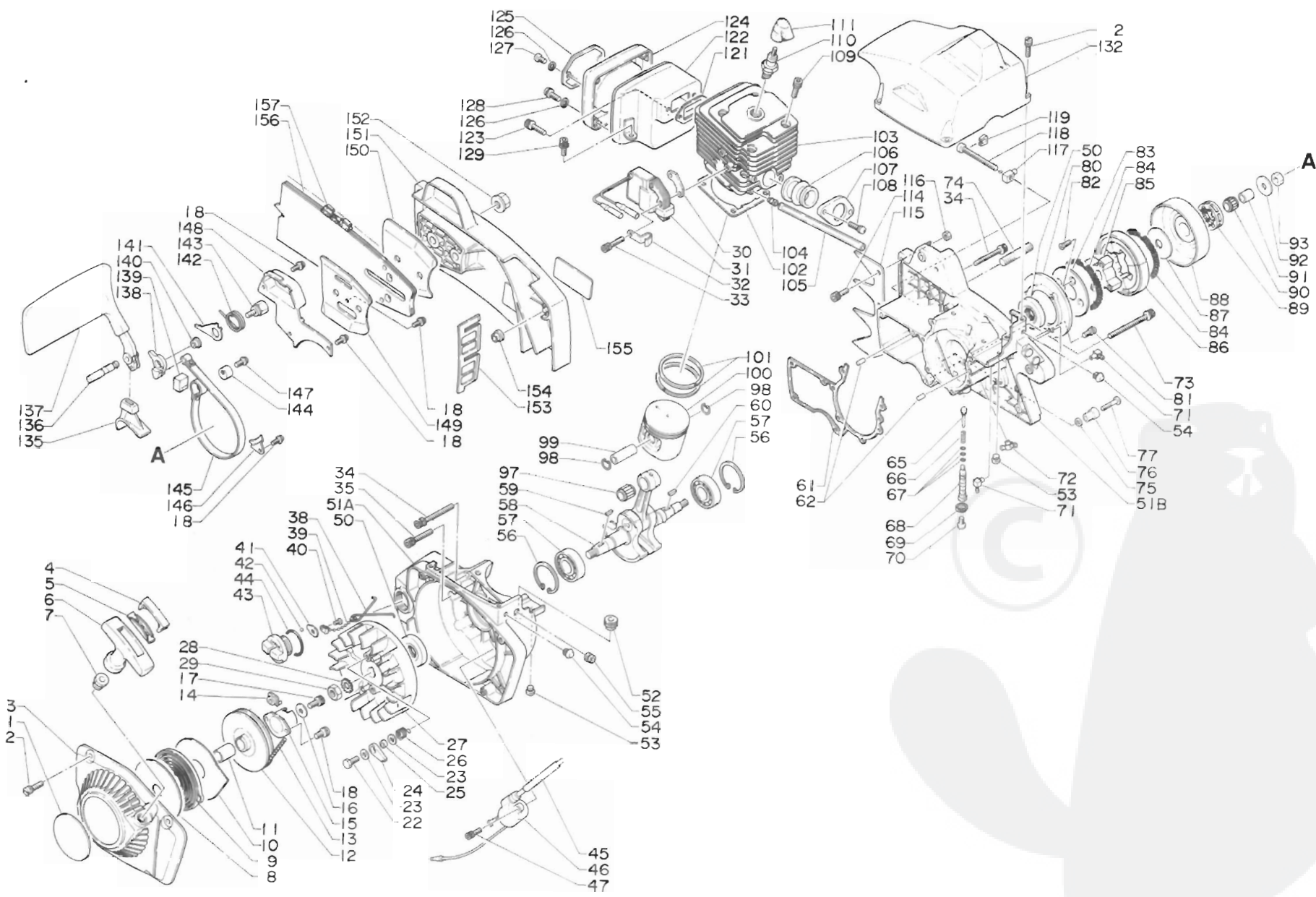

PARTS CATALOGUE

Key No.	Part No.	Q'ty	Description	Key No.	Part No.	Q'ty	Description
1- 1	890 012-1023 0		Decal	1- 86	-175 016-1473 0		Clutch boss
2	101 512-1473 0		Screw 5x20	86	-175 017-1473 0		Clutch shoe
*	<b>177 200-1473 0</b>		<b>Recoil starter ass'y</b>	87	175 015-1063 0		Washer, clutch (Inner)
3	-101 507-1473 0		Fan cover	88	175 006-1473 0		Case, clutch
4	-177 244-1063 0		Cap, handle	89	175 033-1063 0		Rim sproket
5	-177 229-1063 0		Washer	90	100 012-0013 0		Needle bearing
6	-177 228-1063 0		Handle, starter	91	175 013-0023 0		Spacer, clutch case
7	-177 227-1063 0		Rope guide	92	175 014-1063 0		Washer, clutch
8	-177 221-1063 0		Slide plate	93	100 129-1473 0		Nut
9	-177 220-1063 0		Rewind spring	97	100 012-1473 0		Needle bearing
10	-177 242-1473 0		Side plate	98	100 015-0023 0		Circlip, piston pin
11	-177 216-1063 0		Bush	99	100 013-1473 0		Piston pin
12	-177 215-1063 0		Recoil drum	100	100 010-1473 0		Piston
13	-177 226-1473 0		Starter rope	101	100 011-1473 0		Piston ring
14	-177 246-1063 0		Clip	102	101 010-1473 0		Gasket, cylinder
15	-177 243-0283 3		Pawl catcher	103	101 011-1473 0		Cylinder
16	-300 217-0061 0		Washer	104	100 267-1063 0		Connector, impulse
17	-900 162-0501 5		H.s.h. bolt 5x15	105	437 228-1473 0		Oil pipe
18	-900 242-0401 2		Screw 4x12	106	130 510-1473 0		Connector
18	900 242-0401 2		Screw 4x12	107	130 512-1473 0		Holder
22	900 100-0601 6		Bolt 6x16	108	900 242-0502 0		Screw 5x20
23	900 600-0000 6		Washer 6	109	900 168-0602 0		H.s.h. bolt 5x20
24	177 218-0283 0		Ratchet	110	159 010-1063 0		Spark plug (BPM-7A)
25	177 247-0283 0		Spacer, ratchet	111	159 005-0033 1		Cap, spark plug
26	177 234-1473 0		Spring, ratchet	114	900 105-0501 5		H.s.h. bolt 5x15
27	150 801-1473 0		Flywheel	115	880 212-1473 0		Spike bumper
28	900 611-0001 0		Washer 10	116	433 020-0083 0		Lock nut 5
29	100 144-0283 0		Nut	117	433 014-1063 0		Tentioner
30	150 617-1473 0		Spacer	118	433 016-1473 0		Adjusting screw
31	150 601-1473 0		C.D.I. module	119	433 028-1473 0		Clip
32	159 112-1473 0		Clamp	121	145 510-1473 0		Gasket, muffler
33	900 162-0502 5		H.s.h. bolt 5x25	122	145 806-1473 0		Muffler body (S.A.M.)
34	900 162-0505 0		H.s.h. bolt 5x50	123	900 168-0602 0		H.s.h. bolt 5x18
35	900 162-0503 5		H.s.h. bolt 5x35	124	145 807-1473 0		Muffler
43	436 001-1473 0		Cap ass'y, oil tank	125	145 861-1473 0		Muffler lid
44	-900 720-0002 5		O-ring 25	126	900 610-0000 5		Lock washer 5
45	150 611-1473 0		Tube	127	145 643-0373 0		Screw 5x8
46	150 626-1473 0		Ignition coil	128	145 643-1063 0		Screw 5x16
47	900 162-0401 6		H.s.h. bolt 4x16	129	900 106-0501 5		H.s.h. bolt 5x12
50	100 212-1213 0		Oilseal	132	101 514-1473 0		Cover, cylinder
51	100 206-1473 0		Crankcase set	***	433 100-1473 0		Chain brake ass'y
52	153 110-0283 0		Bush	18	-900 242-0401 2		Screw 4x12
53	100 251-1473 0		Cushion (A)	135	-433 312-1233 0		Cover, brake lever
54	100 252-1473 0		Cushion (B)	136	-433 113-1233 0		Screw
55	132 115-0146 0		Grommet	137	-433 105-1473 0		Brake handle
56	900 702-0004 0		Circlip (CR-40)	138	-433 117-1473 0		Connector
57	900 810-0620 3		Ball bearing (6203)	139	-433 313-1473 0		Dust seal
58	100 100-1473 0		Crankshaft ass'y	140	-433 115-1233 0		Spacer
59	100 142-1233 0		Woodruff key	141	-433 119-1233 0		Stopper
60	900 322-0301 4		Woodruff key	142	-433 114-1233 0		Return spring
61	100 242-1473 0		Gasket, crankcase	143	-433 134-1233 0		Connector
62	100 215-0283 0		Knock pin	144	-433 142-1473 0		Adjuster
65	437 002-0343 1		Cylinder & plunger	145	-433 123-1473 0		Brake band
66	437 019-0283 0		Oiler, spring	146	-433 144-1473 0		Band, supporter
67	437 020-0283 0		O-ring	147	-900 241-0501 0		Screw 5x10
69	437 059-1113 3		Pump stopper	148	-433 310-1473 0		Cover
70	437 016-1113 1		Screw	149	433 013-1473 0		Side plate (Inner)
71	437 239-1473 0		Nipple	150	433 012-1473 0		Side plate (Outer)
72	437 240-1473 0		Connector	151	433 010-1473 0		Cover, guide bar
73	900 162-0506 5		H.s.h. bolt 5x65	152	433 019-1063 1		Flange nut
74	433 011-1063 0		Stud, guide bar	153	433 025-1473 0		Protector
75	900 600-0000 5		Washer	154	433 030-1473 0		Knock pin
76	433 006-1283 0		Chain catcher	155	890 021-0283 1		Echo, name plate
77	900 220-0502 5		Screw 5x25	156	430 328-1063 0		Guide bar (65H63)
80	175 310-1473 0		Cover, dustseal	157	431 133-1063 1		Chain (52CP-80E)
81	900 242-0401 0		Screw 4x10				
82	900 212-0501 2		Screw 5x12				
83	175 019-1063 1		Clutch plate				
**	<b>175 000-1473 0</b>		<b>Clutch ass'y</b>				
84	-175 018-1473 0		Spring, clutch				

Remarks:

\* Consists of 3 thru 18.

\*\* Consists of 84 thru 86.

\*\*\* Consists of 18 and 135 thru 148.

Bei Verwendung des neuen Ventilgehäuses 100204 - 14730 andere Ölwanne-  
belüftung!

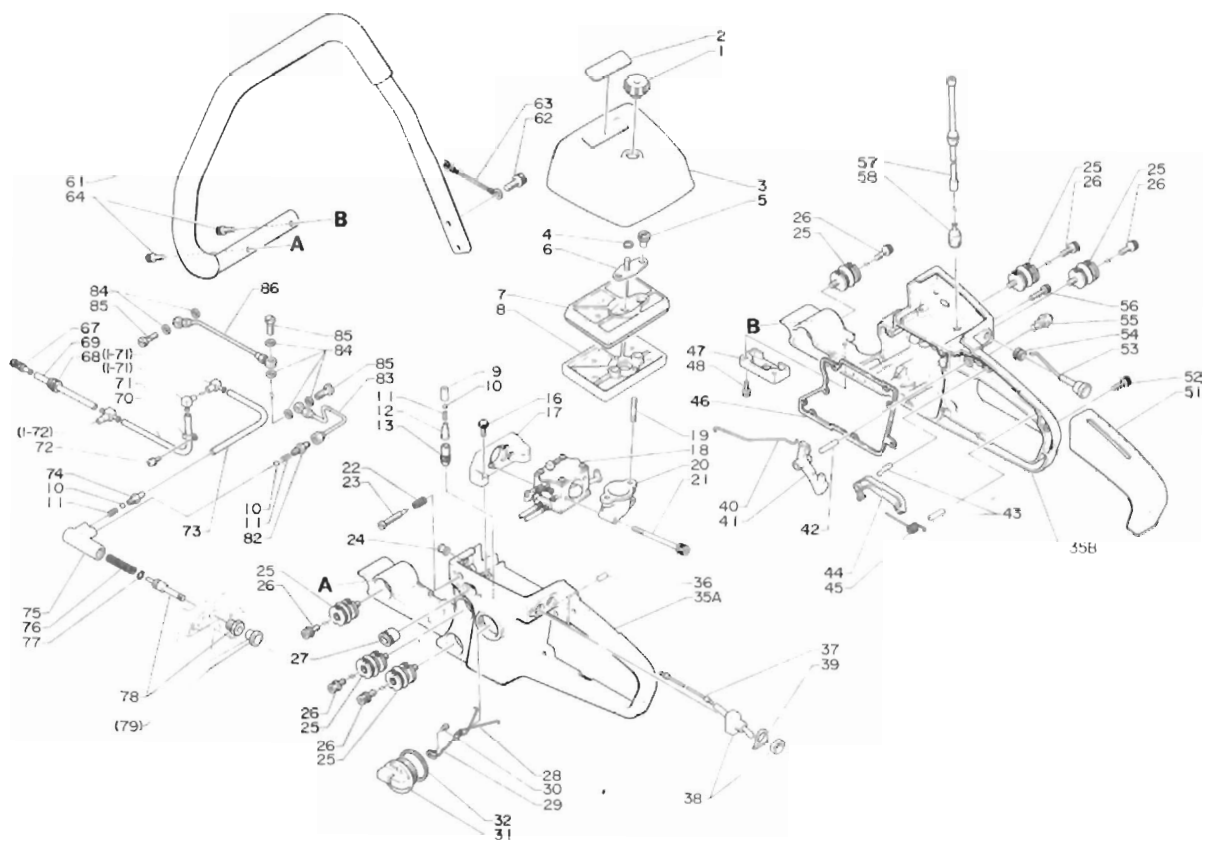

Key No.	Part No.	Q'ty	Description	Key No.	Part No.	Q'ty	Description
2-1	130 406-0033 0		Thumb nut	2-46	131 011-1473 0		Gasket, fuel tank
2	890 151-1473 0		Model plate	47	437 610-1473 0		Pump cover
3	130 313-1473 0		Cover, air cleaner	48	900 242-0401 2		Screw 4x12
4	900 701-0001 1		Circlip	51	351 111-1473 0		Rubber, rear handle
*	130 300-1473 0		Air cleaner ass'y	52	900 162-0401 6		H.s.h. bolt 4x16
5	-130 428-1473 0		Nut, cleaner support	53	178 510-1473 0		Choke rod
6	-130 405-1473 0		Cleaner, set plate	54	178 810-0283 0		Rubber bush
7	-130 310-1473 0		Air cleaner (U)	55	178 302-1233 0		Throttle lock
8	-130 317-1473 0		Air cleaner (L)	56	900 162-0402 0		H.s.h. bolt 4x20
**	131 300-1473 0		Breather ass'y	57	132 010-1473 0		Fuel pipe
9	-131 326-1473 0		Breather (U)	58	131 205-0023 0		Fuel strainer
10	-437 012-0033 0		Ball valve	61	351 604-1473 0		Front handle
11	-437 013-0033 0		Valve spring	62	900 162-0602 5		H.s.h. bolt 6x20
12	-131 327-1473 0		Breather (L)	63	162 010-1473 0		Ground lead wire
13	-131 320-1473 0		Connector	64	900 162-0502 0		H.s.h. bolt 5x20
16	900 242-0501 4		Screw 5x14	67	436 205-0283 2		Oil strainer
17	130 013-1473 0		Carburetor bed	68	132 115-1233 0		Grommet
18	123 000-1473 0		Carburetor Ass'y	69	437 210-1473 0		Oil pipe
19	130 712-1473 0		Bolt	70	437 211-1473 0		Oil pipe
20	130 711-1473 0		Pipe, intake	71	159 110-0283 0		Ctip
21	900 162-0507 5		H.s.h. bolt 5x75	72	900 242-0401 0		Screw 4x10
22	129 020-1473 0		Throttle spring	73	437 228-1473 0		Oil pipe
23	129 013-1473 0		Screw	****	437 100-1473 0		Pump ass'y
24	132 115-0146 0		Grommet	10	-437 012-0033 0		Ball valve
25	100 905-1473 0		Cushion rubber	11	-437 013-0033 0		Valve spring
26	900 162-0501 5		H.s.h. bolt 5x15	74	-437 017-0033 0		Pump connector
27	129 010-1473 0		Grommet	75	-437 110-0023 1		Oil pump body
***	131 004-1473 0		Fuel tank cap ass'y	76	-437 111-0023 1		Spring, oil pump
32	-900 720-0002 9		O-ring	77	-900 720-0000 6		O-ring 8
35	351 100-1473 0		Rear handle set	78	-437 101-1473 0		Pump piston
36	100 215-0283 0		Knock pin	79	-437 119-1473 0		Push button
37	162 021-1473 0		Ground lead wire	82	-437 052-0033 0		Connector
38	163 400-1113 0		Stop switch ass'y	83	437 206-1473 0		Oil pipe
39	890 157-1473 0		Stop label	84	131 310-0023 0		Gasket
40	178 011-1473 0		Throttle connecting rod	85	437 220-1473 0		Holding bolt
41	178 010-1473 0		Throttle trigger	86	437 207-1473 0		Oil pipe
42	900 340-5002 5		Spring pin				
43	900 340-4002 0		Spring pin				
44	178 090-1473 0		Safety lock				
45	178 091-1053 1		Spring, safety lock				

Remarks:

- \* Consists of 5 thru 8.
- \*\* Consists of 9 thru 13.
- \*\*\* Includes 32.
- \*\*\*\* Consists of 10 thru 11 and 74 thru 78 and 82.
- 78 Includes 79.

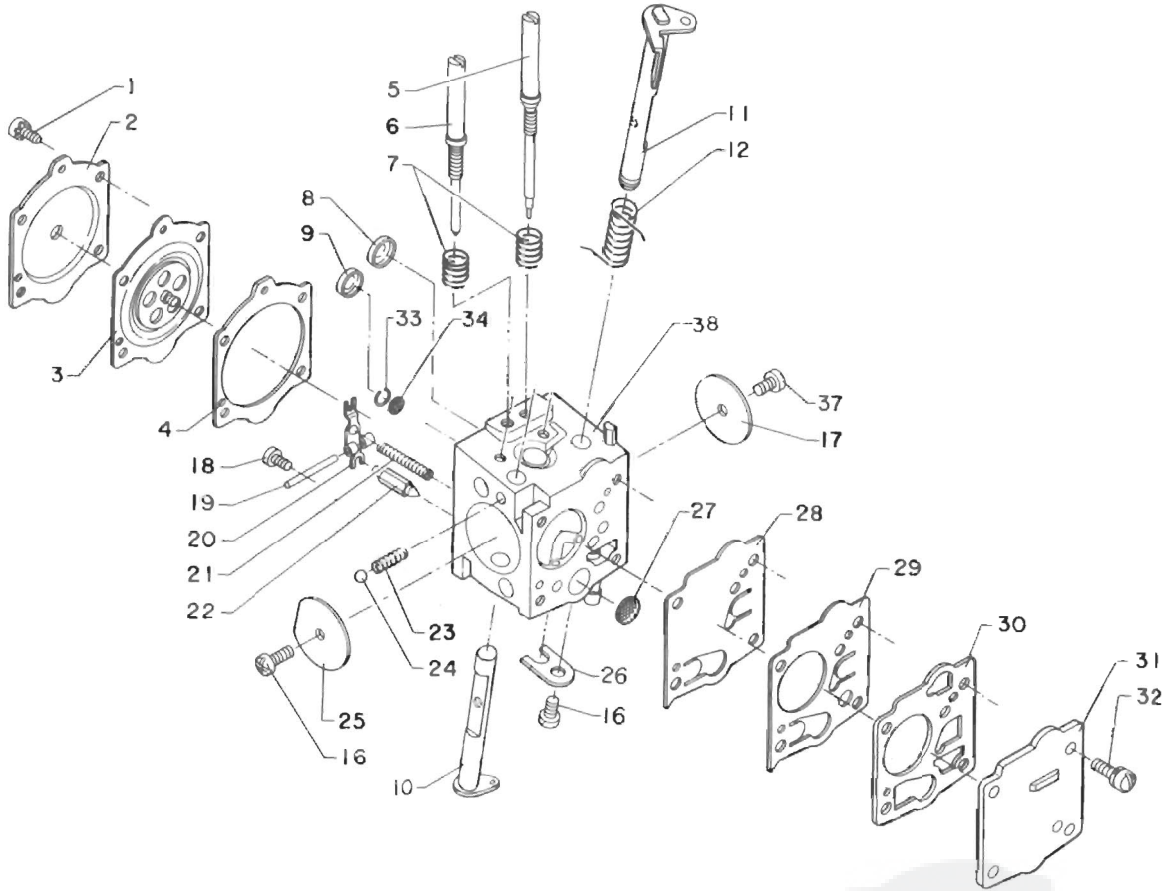

Key No.	Part No.	Q'ty	Description	Key No.	Part No.	Q'ty	Description
<b>3- *</b>	<b>123 000-1473 0</b>		<b>Carburetor ass'y</b>	<b>3-23</b>	-123 135-1063 1		Spring, choke friction
1	-123 144-0393 0		Screw	24	-123 136-1063 1		Ball, choke friction
2	-123 142-1063 0		Cover, metering diaphragm	25	-123 132-1063 0		Valve, choke
3	-123 141-1063 0		Diaphragm, metering	26	-123 127-1063 1		Clip, throttle shaft
4	-123 140-1063 0		Gasket, metering diaphragm	27	-123 126-1063 1		Screen, inlet
5	-123 118-1063 0		Needle, idle	28	-123 112-1063 0		Diaphragm, fuel pump
6	-123 120-1063 0		Needle, high speed	29	-123 111-1063 0		Diaphragm, check valve
7	-123 119-0393 0		Spring, needle	30	-123 125-1243 0		Gasket, fuel pump
8	-123 145-1063 0		Plug, welch	31	-123 124-1473 0		Cover, fuel pump
9	-123 146-1063 0		Plug, welch	32	-123 110-1063 0		Screw, pump cover
10	-123 131-1473 0		Shaft, choke	33	-123 169-1063 0		Ring, retaining
11	-123 117-1473 0		Shaft, throttle	34	-123 168-1063 0		Screen
12	-123 113-1063 1		Spring, throttle return	37	-123 114-1063 0		Screw
16	-123 154-1063 0		Screw	38	-NOT AVAILABLE		Body ass'y, carburetor
17	-123 116-1473 0		Valve, throttle				
18	-123 139-0393 0		Screw, metering lever pin				
19	-123 138-1063 0		Pin, metering lever				
20	-123 123-1063 0		Lever, metering				
21	-123 122-1063 0		Spring, metering lever				
22	-123 137-0393 0		Valve, inlet needle				

Remarks:

*New brass  
123 103-14730*