

**Flymo**

**GCL 75 UNITS 9637501 9637502  
9637503**

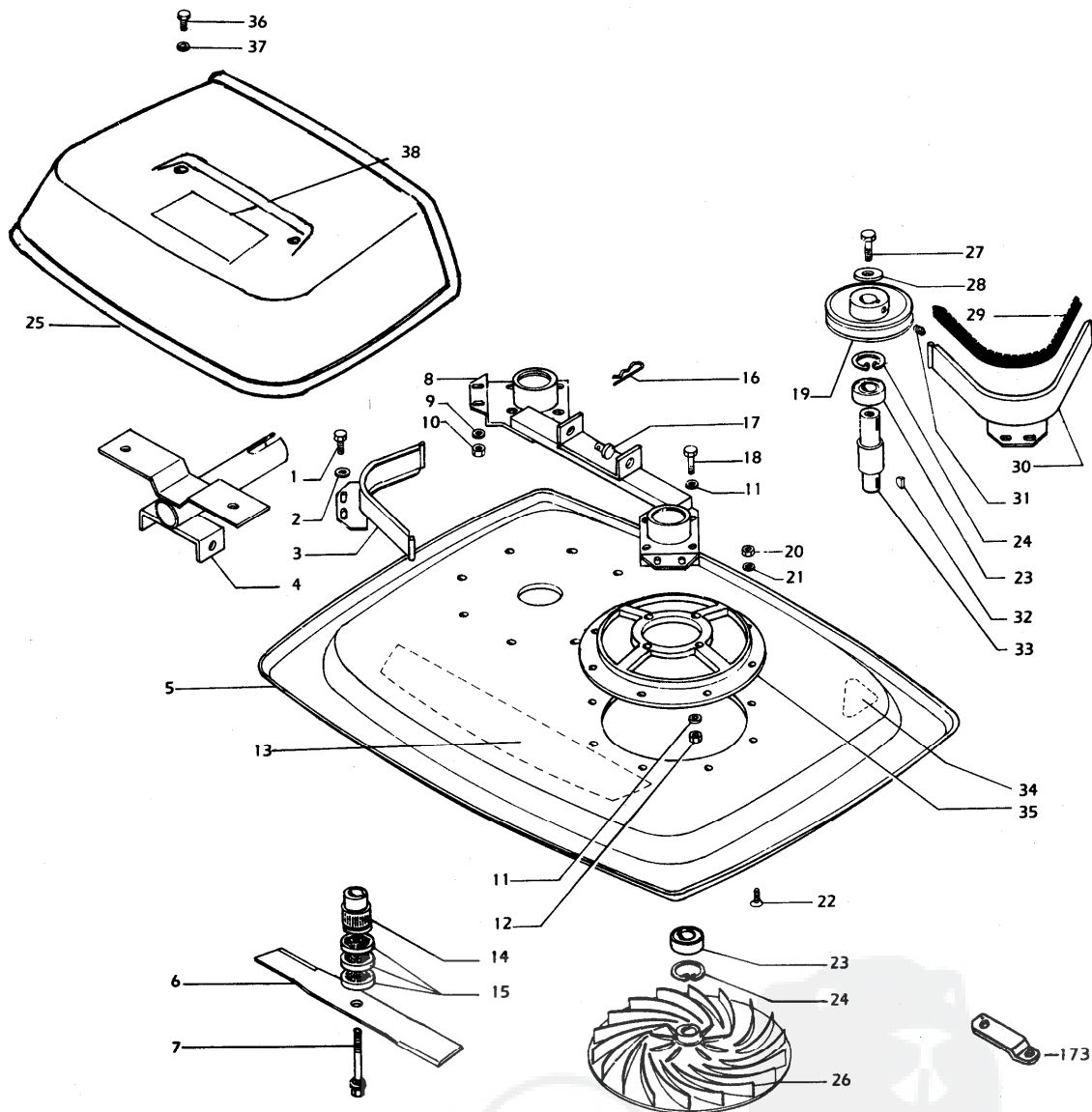

KEY No.	PART No	DESCRIPTION	QUANTITY	COMMENTS APPLICATION	KEY No.	PART No	DESCRIPTION	QUANTITY	COMMENTS APPLICATION
1	5195097-00/0	BOLT 5/16" x 3/4	4		20	5195087-00/1	NUT NYLOC 1/4	16	
2	5195079-00/8	WASHER 5/16" I.D.	4		21	5195080-00/6	WASHER 1/4" I.D.	16	
3	5195041-00/8	BELT GUARD R/H	1		22	5195092-00/1	SCREW 1/4 x 3/4	16	
* 4	5195039-00/2	BRACKET, ROUND SECTION	1	EARLY PRODUCTS	23	5141318-00/5	BEARING	4	
* 4	5195113-00/5	BRACKET, SQUARE SECTION	1	LATER PRODUCTS	24	5195067-00/3	CIRCLIP	4	
5	5110334-01/7	HOOD 75CM	1		25	5100023-02/6	COWL	1	
6	5120338-00/8	BLADE 38CM	2		26	5116968-00/8	IMPELLER	1	
7	5146677-04/1	BOLT BLADE 75MM LONG	2		27	5195106-00/9	BOLT M6	2	
8	5195040-00/0	BEARING HOUSING ASSY	1		28	5195069-00/9	WASHER DOMED	2	
9	5195079-00/8	WASHER 5/16" I.D.	4		29	5195043-00/4	BELT CUTTER	1	
10	5195088-00/9	NUT NYLOC 5/16"	4		30	5195042-00/6	BELT GUARD L/H	1	
11	5195079-00/8	WASHER 5/16" I.D.	8		31	5195085-00/5	GRUBSCREW 5/16" x 5/8W	2	
12	5195088-00/9	NUT NYLOC 5/16"	8		32	5195074-00/9	KEY WOODRUFF	4	
13	5117253-00/4	LABEL FLYMO	1		33	5195046-00/7	SHAFT CUTTER UNIT	2	
14	5116508-00/2	INSERT IMPELLER	1		34	5137747-00/1	LABEL (FINGER WARNING)	2	
15	5140001-00/8	BLADE SPACER	3		35	5120350-00/3	ENGINE BRACKET	2	
16	5195075-00/6	R CLIP	2		36	5195097-00/0	BOLT 5/16" x 3/4	2	
17	5195061-00/6	CLEVIS PIN	2		37	5195079-00/8	WASHER 5/16" I.D.	2	
18	5195097-00/0	BOLT 5/16" x 3/4	8		38	5137783-00/6	LABEL GCL 75	1	
19	5195044-00/2	PULLEY CUTTER UNIT	2		173	5130109-00/1	SPANNER	1	

\* SEE NOTES ON PAGE F20-E

**Flymo**

**GCL 75 SULKY 9637503**

Bolts 5/16" UNF x 3/4"	4 Sulky axle to frame
Washers 5/16" ID x 5/8" OD	8 Sulky axle to frame
Nuts 5/16" UNF Nylocs	4 Sulky axle to frame
Bolt 3/8" UNC x 3/4"	4 Seat to frame
Washers 3/8" ID x 1 1/8" OD	4 Seat to frame
Washers 3/8" ID shakeproof	4 Seat to frame
'R' clip 3mm	1 Towing hitch (not shown)
Bolt 3/8" UNF x 2 3/4"	1 Frame/Seat adjustment
Nut 3/8" UNF Nyloc	1 Frame/Seat adjustment
Washer 3/8" ID x 1 1/8" OD	2 Frame/Seat adjustment
Split pin 1/8" OD x 1 1/2"	2 Sulky wheel mounting
Washers 3/4" ID x 1 1/2" OD	4 Sulky wheel mounting
Bolt 5/16" UNF x 1"	2 Footrest bracket to chassis
Washer 5/16" ID x 5/8" OD	2 Footrest bracket to chassis

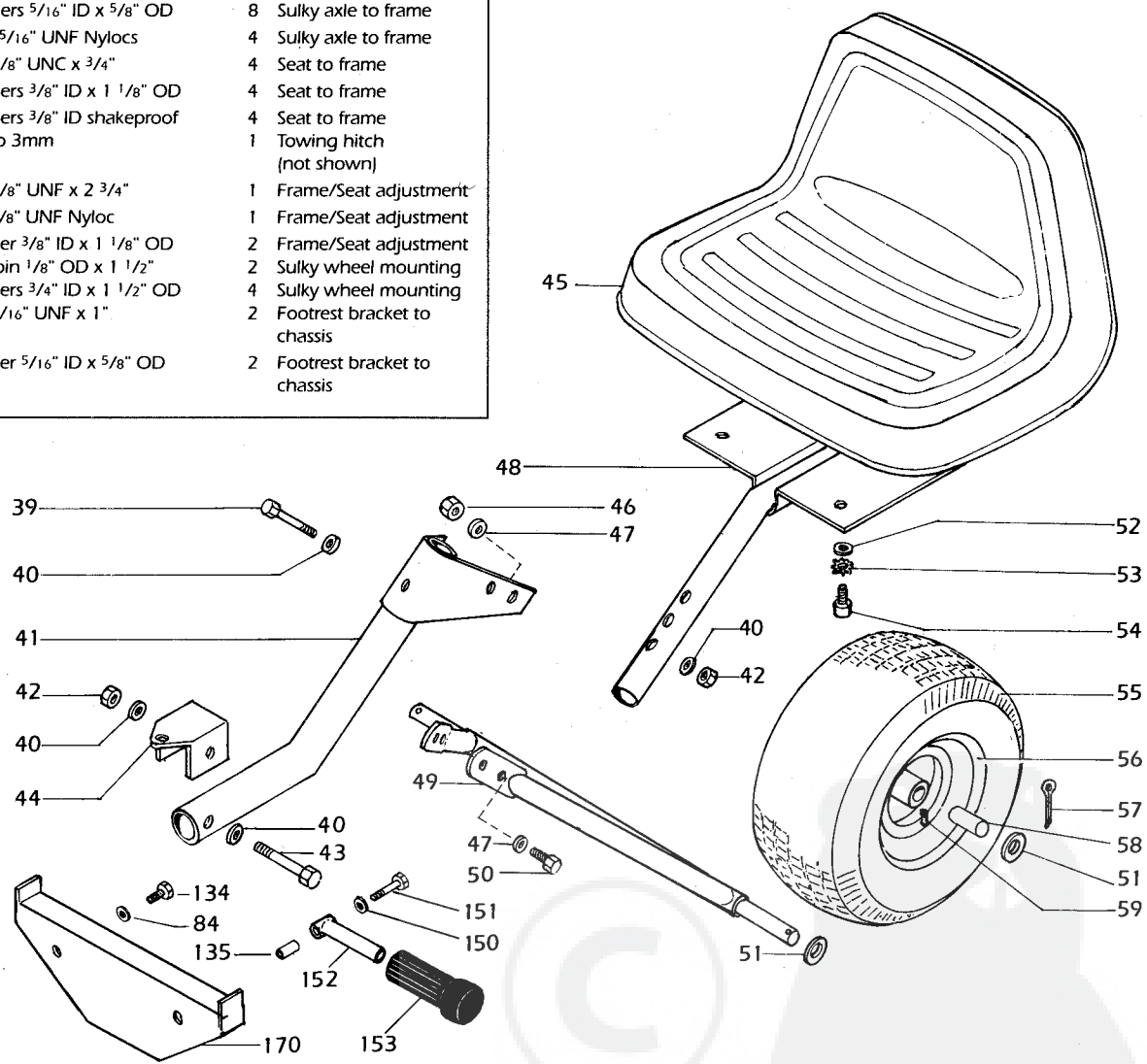

KEY No.	PART No	DESCRIPTION	QUANTITY	COMMENTS APPLICATION	KEY No.	PART No	DESCRIPTION	QUANTITY	COMMENTS APPLICATION
39	5195110-00/1	BOLT 5/16" UNF x 2 3/4"	1		54	5195103-00/6	BOLT 3/8" x 3/4"	4	
40	5195078-00/0	WASHER 3/8" I.D.	4		55	5195009-00/5	TYRE 13 x 550-6	2	
41	5195050-00/9	FRAME TOWING HITCH	1		56	5195008-00/7	HUB WHEEL	2	
42	5195089-00/7	NUT NYLOC 3/8"	2		57	5195076-00/4	SPLIT PIN 1/8"	2	
43	5195104-00/4	BOLT 3/8" x 3"	1		58	5195070-00/7	BUSH WHEEL	2	
44	5195049-00/1	BRACKET HITCH	1		59	5195010-00/3	TUBE TYRE	2	
45	5195047-00/5	SEAT SULKY	1		84	5195079-00/8	WASHER	2	
46	5195088-00/9	NUT NYLOC 5/16"	4		134	5195098-00/8	BOLT	2	
47	5195079-00/8	WASHER 5/16" I.D.	8		135	5195060-00/8	SPACER	2	
48	5195048-00/3	FRAME SULKY SEAT	1		150	5195079-00/8	WASHER	2	
49	5195051-00/7	FRAME AXLE	1		151	5195101-00/0	BOLT	2	
50	5195097-00/0	BOLT 5/16" x 3/4"	4		152	5195021-00/0	FOOT REST	2	
51	5195081-00/4	WASHER 3/4" I.D.	4		153	5195022-00/8	RUBBER FOOTREST	2	
52	5195078-00/0	WASHER 3/8" I.D.	4		170	5195020-00/2	SUPPORT FOOTREST	2	
53	5195084-00/8	WASHER STARLOCK	4						



GCL 75 UNITS 9637501 9637502 9637503

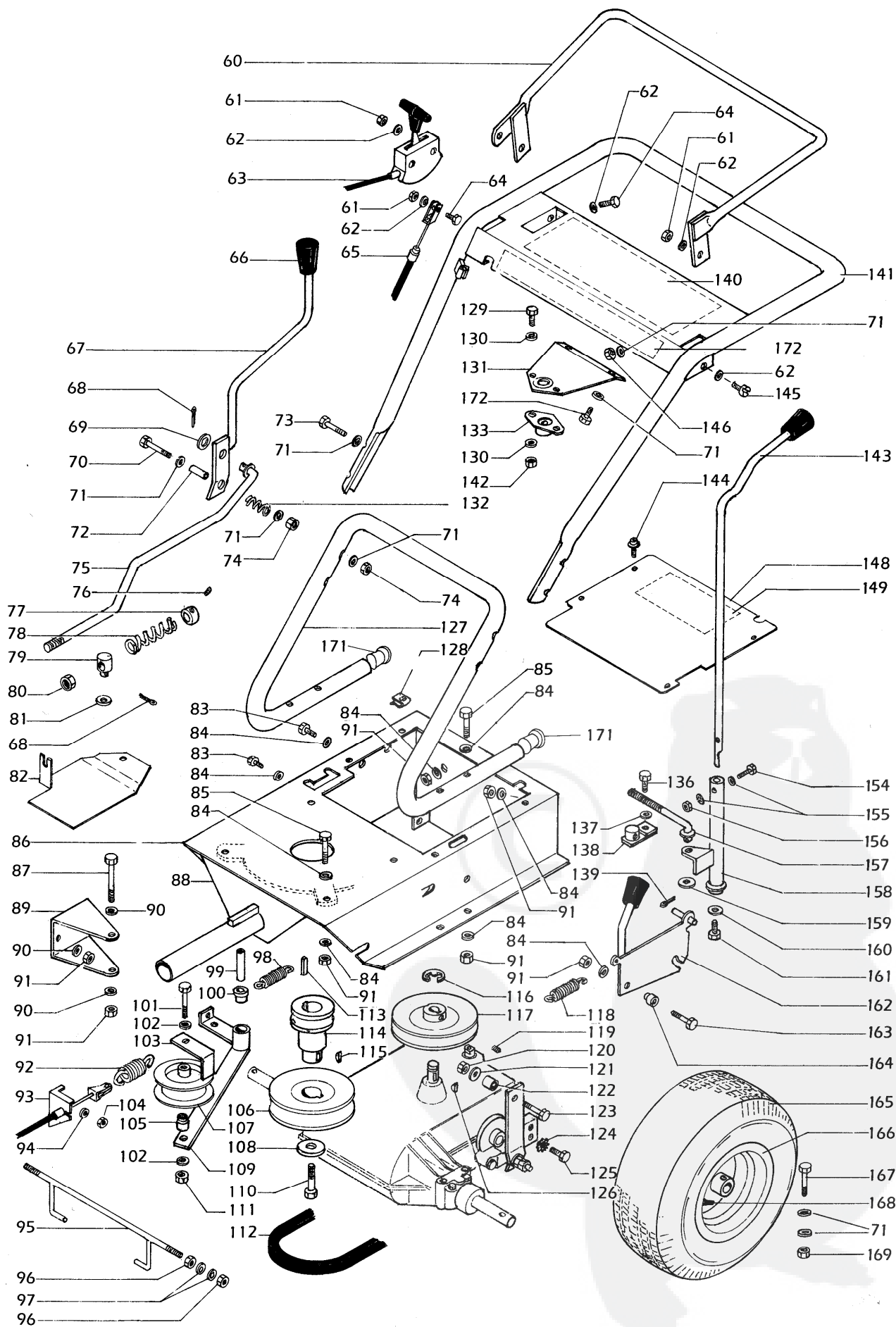



# GCL 75 UNITS 9637501 9637502 9637503

KEY No.	PART No	DESCRIPTION	QUANTITY	COMMENTS APPLICATION	KEY No.	PART No	DESCRIPTION	QUANTITY	COMMENTS APPLICATION
60	5195013-00/7	LEVER BAIL	1		114	5195034-00/3	PULLEY ENGINE	1	
61	5195086-00/3	NUT NYLOC 2BA	4		115	5195074-00/9	KEY WOODRUFF	1	
62	5195082-00/2	WASHER 2BA	6		116	5195068-00/1	CIRCLIP	1	
63	5195036-00/8	THROTTLE CONTROL	1		117	5195035-00/0	PULLEY TRANSAXLE	1	
64	5195091-00/3	SCREW 2BA x 1.5"	3		118	5195065-00/7	SPRING	1	
65	5195037-00/6	CABLE CLUTCH	1		119	5195085-00/5	GRUBSCREW 5/16 x 5/8W	1	
66	5195015-00/2	KNOB LEVER	3		120	5195087-00/1	NUT NYLOC 1/4	1	
67	5195014-00/5	LEVER DRIVE CUTTER	1		121	5195080-00/6	WASHER 1/4" I.D.	1	
68	5195077-00/2	SPLIT PIN 1/8	1		122	5195058-00/2	BRAKE ARM SPACER	1	
69	5195078-00/0	WASHER 3/8" I.D.	1		123	5195093-00/9	BOLT 1/4 x 3/4	1	
70	5195101-00/0	BOLT 5/16 x 2	1		124	5195083-00/0	WASHER 5/16" STARLOCK	1	
71	5195079-00/8	WASHER 5/16" I.D.	6		125	5195107-00/7	BOLT M8	1	
72	5195054-00/1	PIVOT DECK	1		126	5147609-00/1	KEY T/AXLE INPUT SHAFT	1	
73	5195100-00/2	BOLT 5/16 x 1.75"	2		127	5195011-00/1	HANDLE LOWER	1	
74	5195088-00/9	NUT NYLOC 5/16	4		128	5195109-00/3	SPEED CLIP	4	
75	5195016-00/0	ROD CUTTER DRIVE	1		129	5195092-00/1	SCREW 1/4 x 3/4	2	
76	5195085-00/5	GRUBSCREW 5/16 x 5/8W	1		130	5195080-00/6	WASHER 1/4" I.D.	4	
77	5195055-00/8	BOSS SPRING	1		131	5195023-00/6	BRACKET GEAR LEVER	1	
78	5195063-00/2	SPRING	1		132	5195066-00/5	SPRING	1	
79	5195052-00/5	TRUNION	1		133	5195024-00/4	BEARING SUPPORT	1	
80	5195089-00/7	NUT NYLOC 3/8	1		136	5195093-00/9	BOLT 1/4 x 3/4	1	
81	5195078-00/0	WASHER 3/8" I.D.	1		137	5195080-00/6	WASHER 1/4" I.D.	1	
82	5195025-00/1	SHIELD EXHAUST	1		138	5195053-00/3	GEAR LINK PLATE	1	
83	5195097-00/0	BOLT 5/16 x 3/4	4		139	5195077-00/2	SPLIT PIN 1/8	1	
84	5195079-00/8	WASHER 5/16" I.D.	12		140	5126953-00/8	LABEL STARTING	1	
85	5195099-00/6	BOLT 5/16 x 1.5"	4		141	5195012-00/9	HANDLE UPPER	1	
86	5195006-00/1	CHASSIS GCL 75	1		142	5195087-00/1	NUT NYLOC 1/4	2	
87	5195102-00/8	BOLT 5/16 x 2.5	1		143	5195017-00/8	LEVER GEAR	1	
* 88	5195056-00/6	CHASSIS COUPLING ROUND	1	EARLY PRODUCTS	144	5195108-00/5	SCREW 3/16 S.T.	4	
* 88	5195114-00/3	CHASSIS COUPLING SQUARE	1	LATER PRODUCTS	145	5195090-00/5	SCREW 2BA x 1/2	1	
89	5195026-00/9	BRACKET PIVOT	1		146	5195088-00/9	NUT NYLOC 5/16	2	
90	5195079-00/8	WASHER 5/16" I.D.	3		147	5195097-00/0	BOLT 5/16 x 3/4	2	
91	5195088-00/9	NUT NYLOC 5/16	12		148	5195007-00/9	CHASSIS COVER	1	
92	5195064-00/0	SPRING	1		149	5146485-00/7	LABEL WARNING	1	
93	5195027-00/7	BRACKET CLUTCH CABLE	1		154	5195094-00/7	BOLT 1/4 x 1"	1	
94	5195080-00/6	WASHER 1/4" I.D.	1		155	5195080-00/6	WASHER 1/4" I.D.	1	
95	5195028-00/5	BELT GUIDE	1		156	5195087-00/1	NUT NYLOC 1/4	1	
96	5195088-00/9	NUT NYLOC 5/16	4		157	5195038-00/4	ROD	1	
97	5195079-00/8	WASHER 5/16" I.D.	4		158	5195018-00/6	GEAR TUBE SELECTOR	1	
98	5195065-00/7	SPRING	1		159	5195078-00/0	WASHER 3/8" I.D.	1	
99	5195057-00/4	JOCKEY SPACER	1		160	5195079-00/8	WASHER 5/16" I.D.	1	
100	5195071-00/5	BUSH	1		161	5195096-00/2	BOLT 5/16 x 1/2	1	
101	5195102-00/8	BOLT 5/16 x 2.5	1		162	5195019-00/4	LEVER PARKING BRAKE	1	
102	5195079-00/8	WASHER 5/16" I.D.	2		163	5195099-00/6	BOLT 5/16 x 1.5"	1	
103	5195033-00/5	GUIDE BRACKET	1		164	5195059-00/0	BRAKE PIVOT	1	
104	5195087-00/1	NUT NYLOC 1/4	1		165	5195009-00/5	TYRE	2	
105	5195112-00/7	BUSH	1		166	5195062-00/4	WHEEL HUB	2	
106	5195044-00/2	PULLEY CUTTER UNIT	1		* 167	5195095-00/4	BOLT 1/4 x 1.75"	2	EARLY PRODUCTS
107	5195031-00/9	PULLEY CLUTCH	1		* 167	5195100-00/2	BOLT 5/16" x 1.75"	2	LATER PRODUCTS
108	5195069-00/9	WASHER DOMED	1		168	5195010-00/3	TYRE 13 x 550-6	2	
109	5195030-00/1	ARM CLUTCH PULLEY	1		* 169	5195087-00/1	NUT NYLOC 1/4	2	EARLY PRODUCTS
110	5195105-00/1	BOLT 7/16 x 2.5	1		* 169	5195088-00/9	NUT NYLOC 5/16"	2	LATER PRODUCTS
111	5195088-00/9	NUT NYLOC 5/16	1		171	5195111-00/9	PLASTIC CAP	2	
112	5195029-00/3	BELT	1		172	5195071-00/5	BUSH	1	
113	5195073-00/1	KEY ENGINE	1						

\* SEE NOTES ON PAGE F20-E