

MODEL	RXE300
PRODUCT NO.	9633051

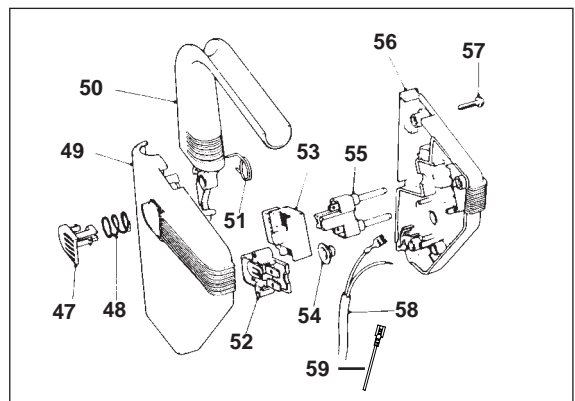

Flymo

MODEL	RXE300
PRODUCT NO.	9633051

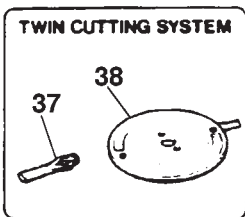
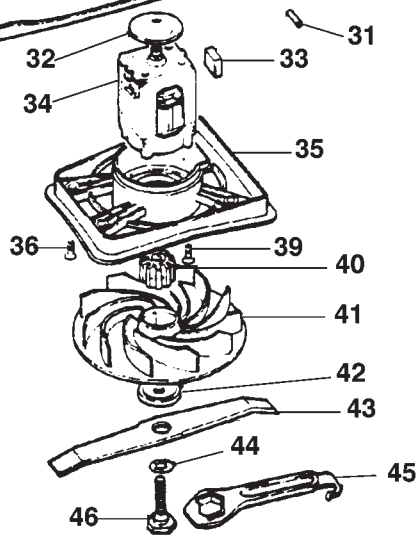
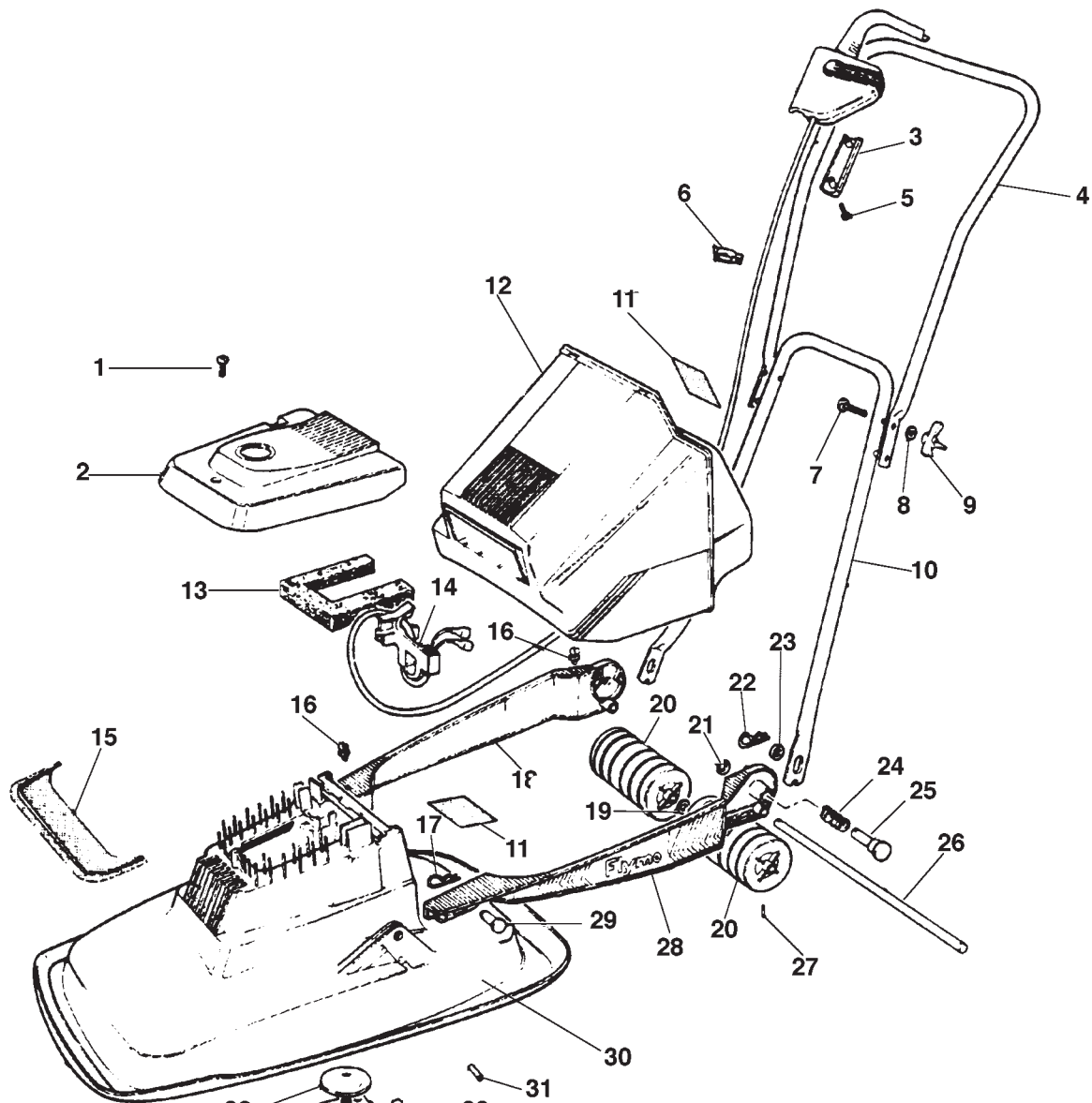

KEY PARTNUMBER	DESCRIPTION	QTY	
01	5146736-00/3	SCREW	1
02	5126821-07/2	COVER ASSEMBLY	1
03	5117364-01/7	RETAINER	1
04	5126816-17/1	HANDLE ASSY, UPPER	1
05	5148552-01/0	SCREW	2
06	5137750-00/5	CABLE CLIP	2
07	5140607-00/2	BOLT, HANDLE	2
08	5140266-00/7	WASHER	2
09	5140690-03/2	WING KNOB	2
10	5117526-00/3	HANDLE ASSEMBLY, LOWER	1
11	5146467-00/5	LABEL, WARNING	2
12	5117079-04/5	GRASSBOX ASSY	1
13	5137638-00/2	FILTER	1
14	5126741-00/7	CLAMP	1
15	5126885-00/2	LABEL, FLYMO	1
16	5148885-00/6	CABLE CLIP	2
17	5140423-00/4	SPRING CLIP	2
18	5106453-00/3	ROLLER SUPPORT-R/H	1
19	5140281-01/4	WASHER	1
20	5137975-00/8	ROLLER	2
21	5148526-00/6	E-CLIP	2
22	5140423-00/4	SPRING CLIP	2
23	5140281-01/4	WASHER	2
24	5137708-00/3	RATCHET SPRING	2
25	5138003-00/8	PIN	2
26	5137974-00/1	SHAFT	1
27	5148477-00/2	DRIVE PIN	2
28	5106454-00/1	ROLLER SUPPORT-L/H	1
29	5140092-00/7	PIVOT PIN	2
30	5126819-01/9	HOOD	1
31	5147594-00/5	PIN	2
32	5146469-01/9	WARNING DISC ASSY	1
33	322814-00/5	RECTIFIER	1
34	5126820-01/7	MOTOR, 240V	1
35	5106279-00/2	MOTOR MOUNTING PLATE	1
36	5146736-00/3	SCREW	4
37	5148257-02/4	CUTTER, PLASTIC	2
38	5126734-00/2	DISC ASSY	1
39	5148122-01/2	SCREW	4
40	5126764-00/9	INSERT, IMPELLER	1
41	5116967-01/8	IMPELLER	1
42	5136240-01/6	BLADE SPACER	3
43	5126439-00/8	BLADE	1
44	5148259-00/4	WASHER,ANTI-FRICTION	1
45	5126682-00/3	SPANNER/SCRAPER	1
46	5137608-00/5	BLADE BOLT	1
47	5127008-00/0	LOCK OFF	1
48	5148658-00/7	SPRING, LOCK OFF	1
49	5148794-01/8	SWITCHBOX UPPER	1
50	5106481-00/4	LEVER	1
51	5148657-00/9	SPRING,TORSION	1
52	5127030-01/2	THERMAL CUT-OUT	1
53	5137685-00/3	SWITCH	1
54	5148654-00/6	SLEEVE,CUT-OUT	1
55	5137686-00/1	PIN RETAINER	1
56	5106415-03/6	SWITCHBOX LOWER	1
57	5148552-01/0	SCREW	4
58	5148814-03/0	LEAD ASSY	1
59	5148773-00/4	LEAD, INTERNAL	1

PRODUCT APPLICATION

9633051-25 GB

WHERE NO APPLICATION DETAILS ARE SHOWN, PART APPLIES TO ALL COUNTRIES

A Austria; AUS Australia; B Belgium; CND Canada; CH Switzerland; D Germany; DK Denmark; E Spain; EI Eire; F France;
GB Great Britain; I Italy; N Norway; NL Netherlands; NZ New Zealand; O/S Overseas; P Portugal; S Sweden; SF Finland;
USA America; ZA South Africa