

**Ersatzteilliste
Spare Parts List
Liste des pièces de rechange**

KSM 750 BAT

1.049-121.0 KSM 750 PROFI

1.049-684.0 KSM 750 BAT



GRUPPE: 1.0 GRUNDRAHMEN
GROUP: 1.0 BASE FRAME
GRUPPE: 1.0 CADRE

A1

KSM 750 BAT

GRUPPE: 1.0 GRUNDRAHMEN
GROUP: 1.0 BASE FRAME
GRUPPE: 1.0 CADRE



GRUPPE: 1.0 GRUNDRAHMEN
GROUP: 1.0 BASE FRAME
GRUPPE: 1.0 CADRE

B1

KSM 750 BAT

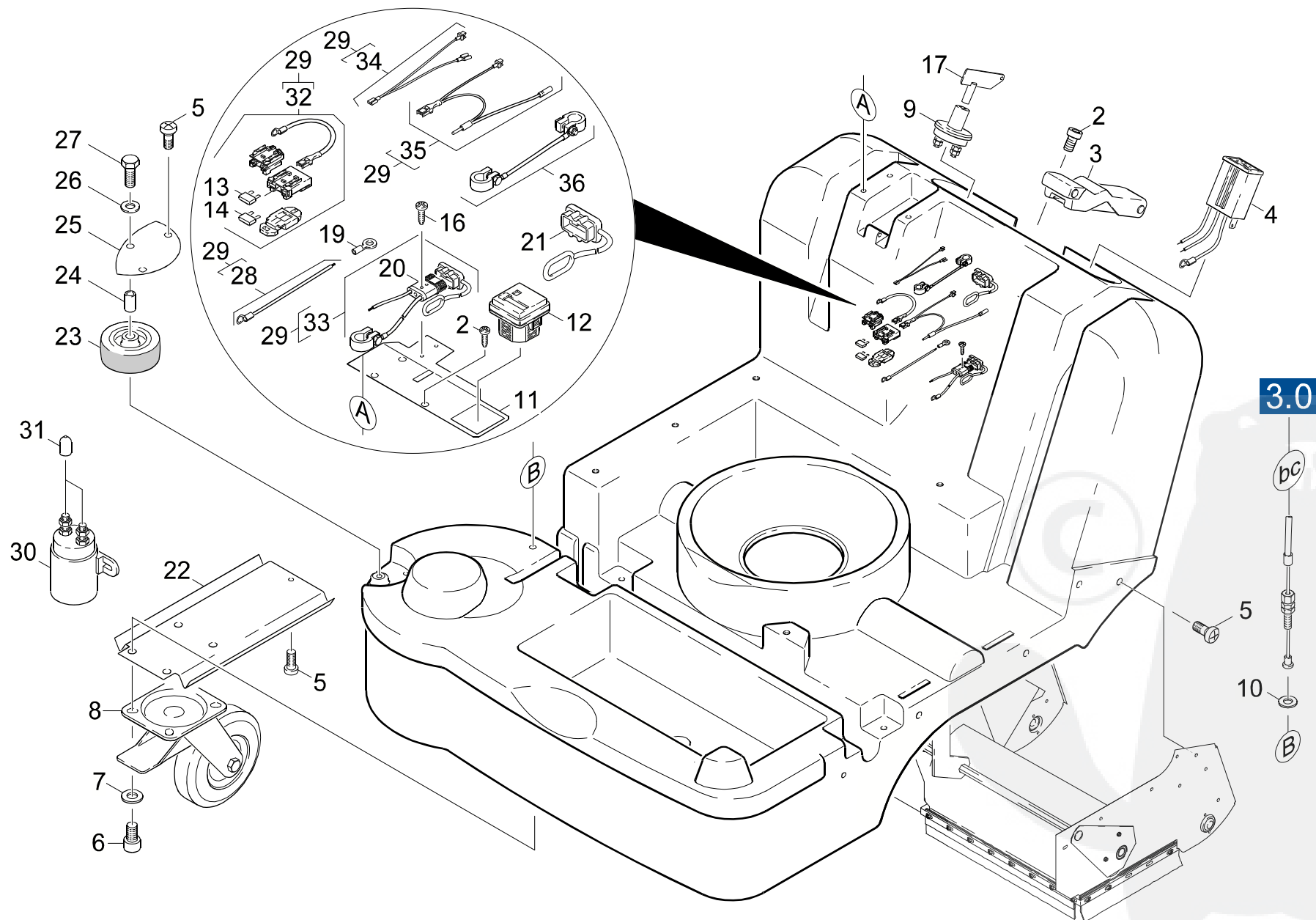

Symbolbeschreibung siehe M16 / symbol description see M16 / désignation de système voir M16 /

GRUPPE: 1.0 GRUNDRAHMEN
 GROUP: 1.0 BASE FRAME
 GROUPE: 1.0 CADRE

C1

KSM 750 BAT

POS. ITM. POS.	BENNENUNNG DESCRIPTION DESIGNATION	TEILE-NR. PART-NO. NO.PIECE	STCK QTY. NBR.	POS. ITM. POS.	BENNENUNNG DESCRIPTION DESIGNATION	TEILE-NR. PART-NO. NO.PIECE	STCK QTY. NBR.
2	SCHRAUBE 5X16 / SCREW / VIS	6.303-155.0	9	25	BLECH / PLATE / TOLE	5.001-849.0	1
3	SPANNVERSCHLUSS / LOCK / MANDRIN	6.375-338.0	1		16670 =>		
4	BATTERIEUEBERWACH. / BATTERY MONITOR / SURVEILLANCE DE BATTERIE	6.682-383.0	1	26	SCHEIBE 6 / WASHER / RONDELLE	7.312-003.0	1
	/ 1.049-121.0				16670 =>		
4	BATTERIEUEBERWACH. / BATTERY MONITOR / SURVEILLANCE DE BATTERIE	6.682-393.0	1	27	6KT-SCHR. M 6X 25 / HEXAGONAL HEAD SCREW / VIS HEXAGONAL	7.304-386.0	1
	/ 1.049-684.0				16670 =>		
5	SCHRAUBE 6,0X20 / SCREW / VIS	6.303-174.0	11	28	KABEL KOMPLETT / CABLE / CABLE	6.647-879.0	1
6	6KT-SCHR. M 8X 16 / HEXAGONAL HEAD SCREW / VIS HEXAGONAL	7.304-395.0	4		/ 1.049-121.0		
7	SCHEIBE 8 / WASHER / RONDELLE	7.312-004.0	4	29	KABELSATZ / CABLE SET / JEU DE CABLES	6.647-931.0	1
8	LENKROLLE / CASTOR / ROUE PIVOTANTE	6.435-322.0	1		/ 1.049-684.0 bis up to jusq. 16669		
9	SCHLUESSELSCHALTER / KEY SWITCH / BOUTON A CLE	6.634-196.0	1	29	KABELSATZ / CABLE SET / JEU DE CABLES	6.648-003.0	1
10	SCHEIBE 6 / WASHER / RONDELLE	7.312-276.0	1		/ 1.049-684.0 ab from a 16670		
11	BLECHTEIL / PLATE / TOLE	5.048-160.0	1	30	RELAIS 24 V / RELAY / RELAIS	6.633-235.0	1
12	BETRIEBSSTUNDENZAEL. / HOUR METRE / COMPTEUR HORRAIRE	6.681-081.0	1		/ 1.049-121.0		
13	E-SICHERUNG 40A / FUSE / FUSIBLE	6.644-246.0	1	30	LEISTUNGSRELAIS / POWER RELAY / RELAIS DE PUISSANCE	6.633-411.0	1
	/ 1.049-121.0				/ 1.049-684.0		
13	FLACHSICHERUNG / FUSE / FUSIBLE DE SECURITE	6.644-272.0	1	31	SCHUTZKAPPE / PROTECTIVE CAP / CAPOT PROTECTION	6.368-294.0	2
	/ 1.049-684.0				/ 1.049-684.0		
14	SICHERUNGSEINS C3 / FUSE INSERT / CARTOUCHE FUSIBLE	7.644-006.0	1	32	KABEL KOMPLETT / CABLE / CABLE	6.647-875.0	1
16	SCHNEIDSCHR. M3X 20 / SELF-TAPPING SCREW / VIS AUTOTARAUEUSE	7.303-501.0	2		/ 1.049-121.0		
17	SCHLUESSEL / KEY / CLE	6.634-201.0	1	33	KABEL KOMPLETT / CABLE / CABLE	6.647-876.0	1
18	FLACHSTECKHUELSE / PLUG SLEEVE / DOUILLE CONNECTOR	6.641-238.0	1		/ 1.049-121.0		
19	KABELSCHUH / CABLE BRACKET / COSSE DE CABLE	6.641-259.0	2	34	KABEL KOMPLETT / CABLE / CABLE	6.647-877.0	1
20	STECKER 50A-2POL / PLUG / FICHE	6.646-140.0	1		/ 1.049-121.0		
	/ 1.049-121.0			35	KABEL KOMPLETT / CABLE / CABLE	6.647-878.0	1
20	STECKER 50A-2POL / PLUG / FICHE	6.646-345.0	1		/ 1.049-121.0		
	/ 1.049-684.0			36	KABEL KOMPLETT / CABLE / CABLE	6.647-874.0	1
21	SCHUTZKAPPE / PROTECTIVE CAP / CAPOT PROTECTION	6.368-278.0	1		/ 1.049-121.0		
22	BLECHTEIL / PLATE / TOLE	5.047-714.0	1				
23	RAD D50 / WHEEL / ROUE	6.435-373.0	1				
	16670 =>						
24	ROHR / PIPE / TUYAU	5.029-334.0	1				
	16670 =>						

"=> xxxxxx" = bis Werknummer / up to serial No. / jusqu' au No. de fabr. / "xxxxxx =>" = ab Werknummer / from serial No. / a partir du No. de fabr. /

GRUPPE: 2.0 HAUBE
GROUP: 2.0 COVER
GRUPPE: 2.0 CAPOT

A2

KSM 750 BAT

GRUPPE: 2.0 HAUBE
GROUP: 2.0 COVER
GRUPPE: 2.0 CAPOT

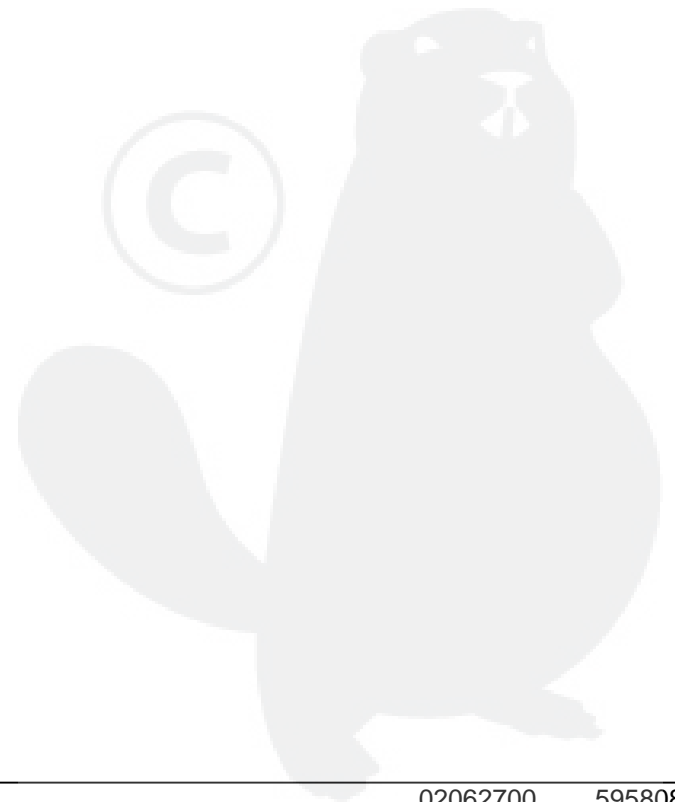

GRUPPE: 2.0 HAUBE
GROUP: 2.0 COVER
GRUPPE: 2.0 CAPOT

B2

KSM 750 BAT

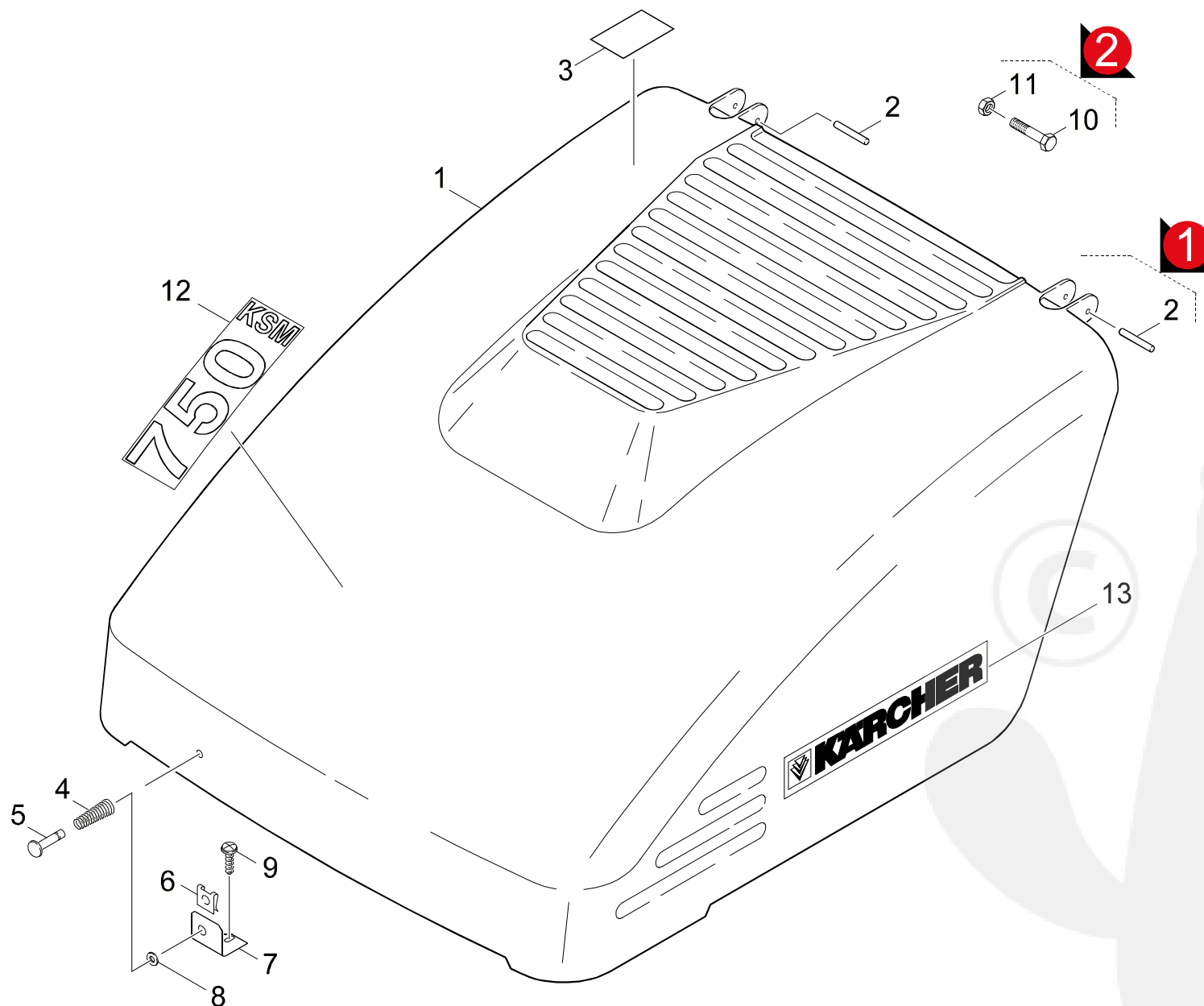

Symbolbeschreibung siehe M16 / symbol description see M16 / désignation de système voir M16 /

GRUPPE: 2.0 HAUBE
GROUP: 2.0 COVER
GRUPPE: 2.0 CAPOT

C2

KSM 750 BAT

POS. ITM. POS.	BENNENUNG DESCRIPTION DESIGNATION	TEILE-NR. PART-NO. NO.PIECE	STCK QTY. NBR.
1	HAUBE / COVER / CAPOT	5.066-861.0	1
2	ACHSE / AXLE / ESSIEU	5.105-214.0	2
3	SCHILD / LABEL / PLAQUE	5.382-041.0	1
4	FEDER / SPRING / RESSORT	6.413-031.0	1
5	ZAPFEN / PIN / TOURILLON	6.316-090.0	1
6	HALTER / BRACKET / FIXATION	6.373-657.0	1
7	WINKEL / ANGLE / ANGLE	5.019-974.0	1
8	SICHERUNGSSCHEIBE / LOCK WASHER / RONDELLE D'ARRET	6.343-223.0	1
9	SCHRAUBE 5X16 / SCREW / VIS	6.303-155.0	1
10	ZYL.SCHR. M 4X 40 / CHEESE HEAD SCREW / VIS A TETE CYLINDR.	7.306-167.0	2
11	6KT-MUTTER M 4 / HEXAGON NUT / ECROU HEXAGONAL	7.311-516.0	2
12	SCHILD / LABEL / PLAQUE	5.380-486.0	1
13	SCHRIFTZUG / CHARACTER / TRAIT	5.390-708.0	2



"=> xxxxxx" = bis Werknummer / up to serial No. / jusqu' au No. de fabr. / "xxxxxx =>" = ab Werknummer / from serial No. / a partir du No. de fabr. /

GRUPPE: 3.0 SCHUBBUEGEL
GROUP: 3.0 SHEARING SHACKLE
GRUPPE: 3.0 L'ARCHET DE POUSEE

A3

KSM 750 BAT

GRUPPE: 3.0 SCHUBBUEGEL
GROUP: 3.0 SHEARING SHACKLE
GRUPPE: 3.0 L'ARCHET DE POUSEE



GRUPPE: 3.0 SCHUBBUEGEL
GROUP: 3.0 SHEARING SHACKLE
GRUPPE: 3.0 L'ARCHET DE POUSEE

B3

KSM 750 BAT

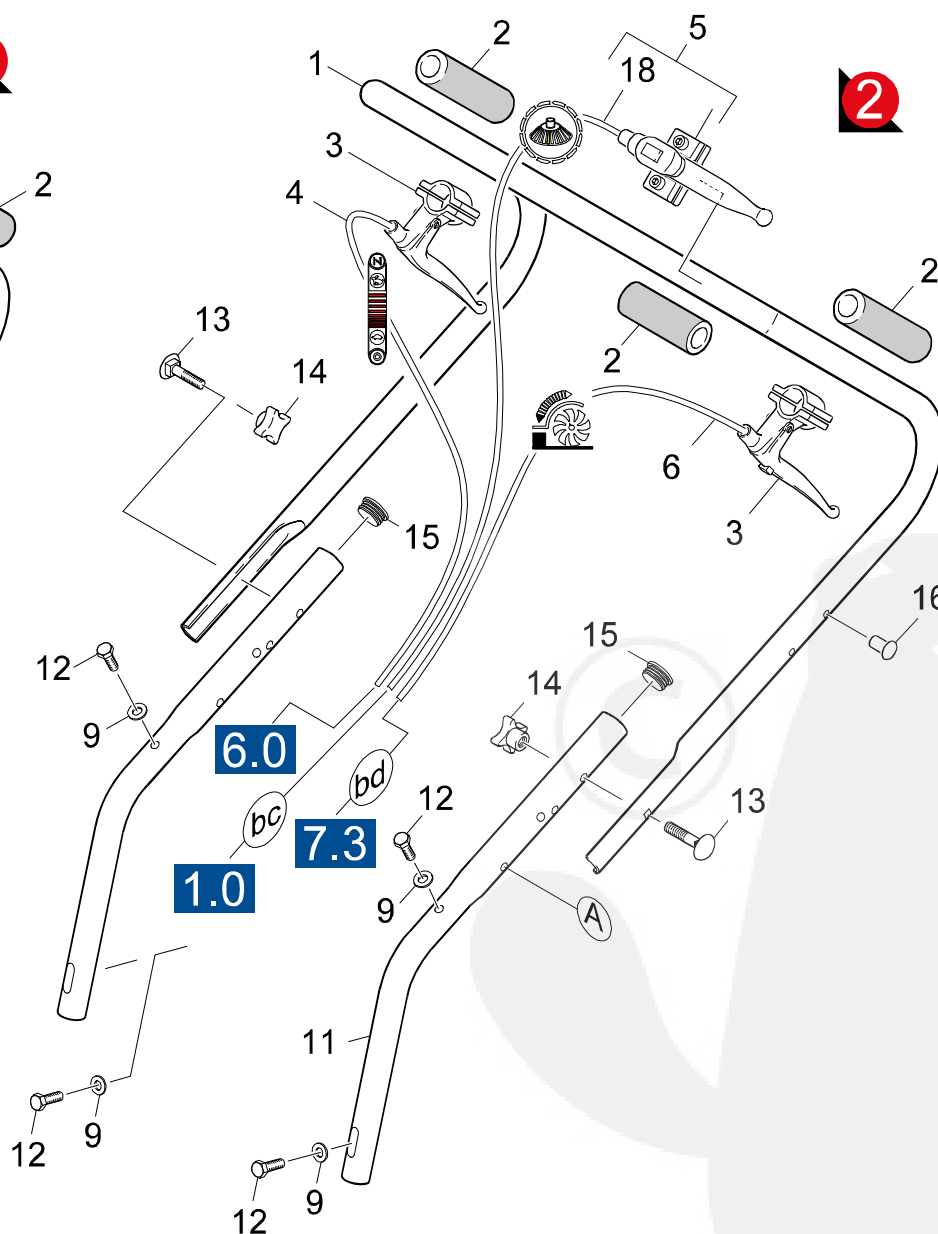
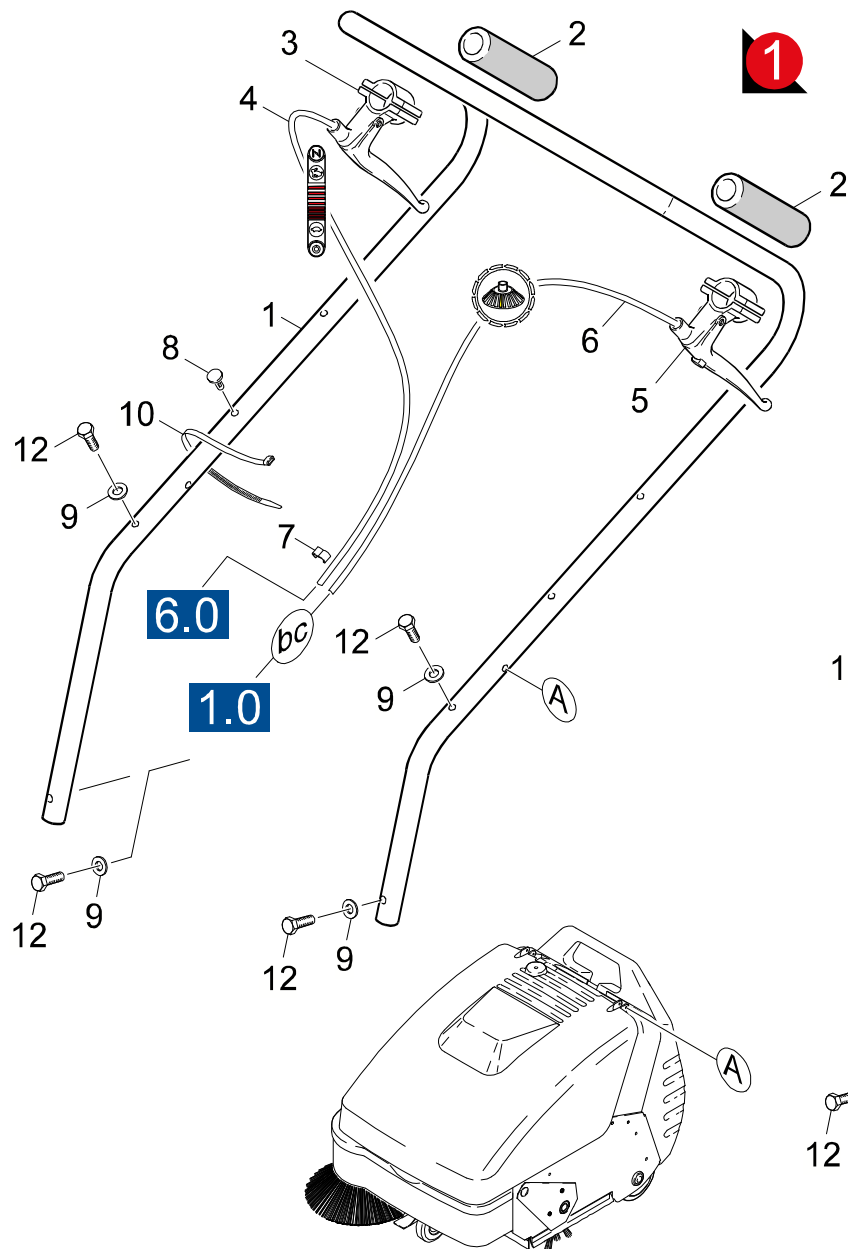

Symbolbeschreibung siehe M16 / symbol description see M16 / désignation de système voir M16 /

GRUPPE: 3.0 SCHUBBUEGEL
 GROUP: 3.0 SHEARING SHACKLE
 GROUPE: 3.0 L'ARCHET DE POUSEE

C3

KSM 750 BAT

POS. ITM. POS.	BENNENNUNG DESCRIPTION DESIGNATION	TEILE-NR. PART-NO. NO.PIECE	STCK QTY. NBR.	POS. ITM. POS.	BENNENNUNG DESCRIPTION DESIGNATION	TEILE-NR. PART-NO. NO.PIECE	STCK QTY. NBR.
1	SCHUBBUEGEL / SHEARING SHACKLE / L'ARCHET DE POUSEE	5.034-640.0	1	18	BOWDENZUG KPL. / BOWDEN WIRE / CABLE SOUS GAINÉ	6.431-123.0	1
2	SCHAUMSTOFFGRIFF / CELLULAR HANDLE / POIGNEE STUECKZAHL NACH BEDARF/QUANTITY ACCORDING TO DEMAND/NOMBRE DE PIECES AU BESOIN	6.321-135.0	3		FETT-SPRAY FUER BOWDENZUG DOSE 400 ML 6.288-107/GREASE SPRAY FOR BOWDEN WIRE 400 ML TIN 6.288-107/GRAISSE POUR CABLE SOUS GAINÉ 400 ML BOITE 6.288-107		
3	BETAETIGUNGSHEBEL / OPERATING LEVER / LEVIER DE MANOEUVRE STUECKZAHL NACH BEDARF/QUANTITY ACCORDING TO DEMAND/NOMBRE DE PIECES AU BESOIN	6.437-467.0	2				
4	BOWDENZUG KPL. / BOWDEN WIRE / CABLE SOUS GAINÉ FETT-SPRAY FUER BOWDENZUG DOSE 400 ML 6.288-107/GREASE SPRAY FOR BOWDEN WIRE 400 ML TIN 6.288-107/GRAISSE POUR CABLE SOUS GAINÉ 400 ML BOITE 6.288-107	6.431-124.0	1				
5	BETAETIGUNGSHEBEL / OPERATING LEVER / LEVIER DE MANOEUVRE	6.437-468.0	1				
6	BOWDENZUG KPL. / BOWDEN WIRE / CABLE SOUS GAINÉ FETT-SPRAY FUER BOWDENZUG DOSE 400 ML 6.288-107/GREASE SPRAY FOR BOWDEN WIRE 400 ML TIN 6.288-107/GRAISSE POUR CABLE SOUS GAINÉ 400 ML BOITE 6.288-107	6.431-198.0	1				
7	DOPPELKABELSCHELLE / CABLE CLAMP / BORNE DE CABLE	6.647-696.0	2				
8	NIET / RIVET / RIVET VERSION 1	6.315-071.0	1				
9	SCHEIBE 6 / WASHER / RONDELLE	7.312-003.0	4				
10	KABELBAND / CABLE TIE / PROTECT. DE CABLE VERSION 1	6.641-465.0	1				
11	ROHR SCHUBBUEGEL / PIPE / TUYAU VERSION 2	5.029-341.0	2				
12	6KT-SCHR. M 6X 30 / HEXAGONAL HEAD SCREW / VIS HEXAGONAL	7.304-387.0	4				
13	FL.RD.SCHR. M 6X 35 / SAUCER-HEAD SCREW / BOULON A TETE BOMBEE VERSION 2	7.303-190.0	2				
14	KREUZGRIFF M 6 / STAR HANDLE / POIGNEE EN ETOILE VERSION 2	6.310-023.0	2				
15	VERSCHLUSSTOPFEN / DRAIN PLUG / BOUCHON VERSION 2	6.368-173.0	2				
16	NIET / RIVET / RIVET VERSION 2	6.315-068.0	4				



"=> xxxxxx" = bis Werknummer / up to serial No. / jusqu' au No. de fabr. / "xxxxxx =>" = ab Werknummer / from serial No. / a partir du No. de fabr. /

GRUPPE: 4.0 ANTRIEB
GROUP: 4.0 ACTUATION
GRUPPE: 4.0 ENTRAINEMENT

A4

KSM 750 BAT

GRUPPE: 4.0 ANTRIEB
GROUP: 4.0 ACTUATION
GRUPPE: 4.0 ENTRAINEMENT



GRUPPE: 4.0 ANTRIEB
GROUP: 4.0 ACTUATION
GRUPPE: 4.0 ENTRAINEMENT

B4

KSM 750 BAT

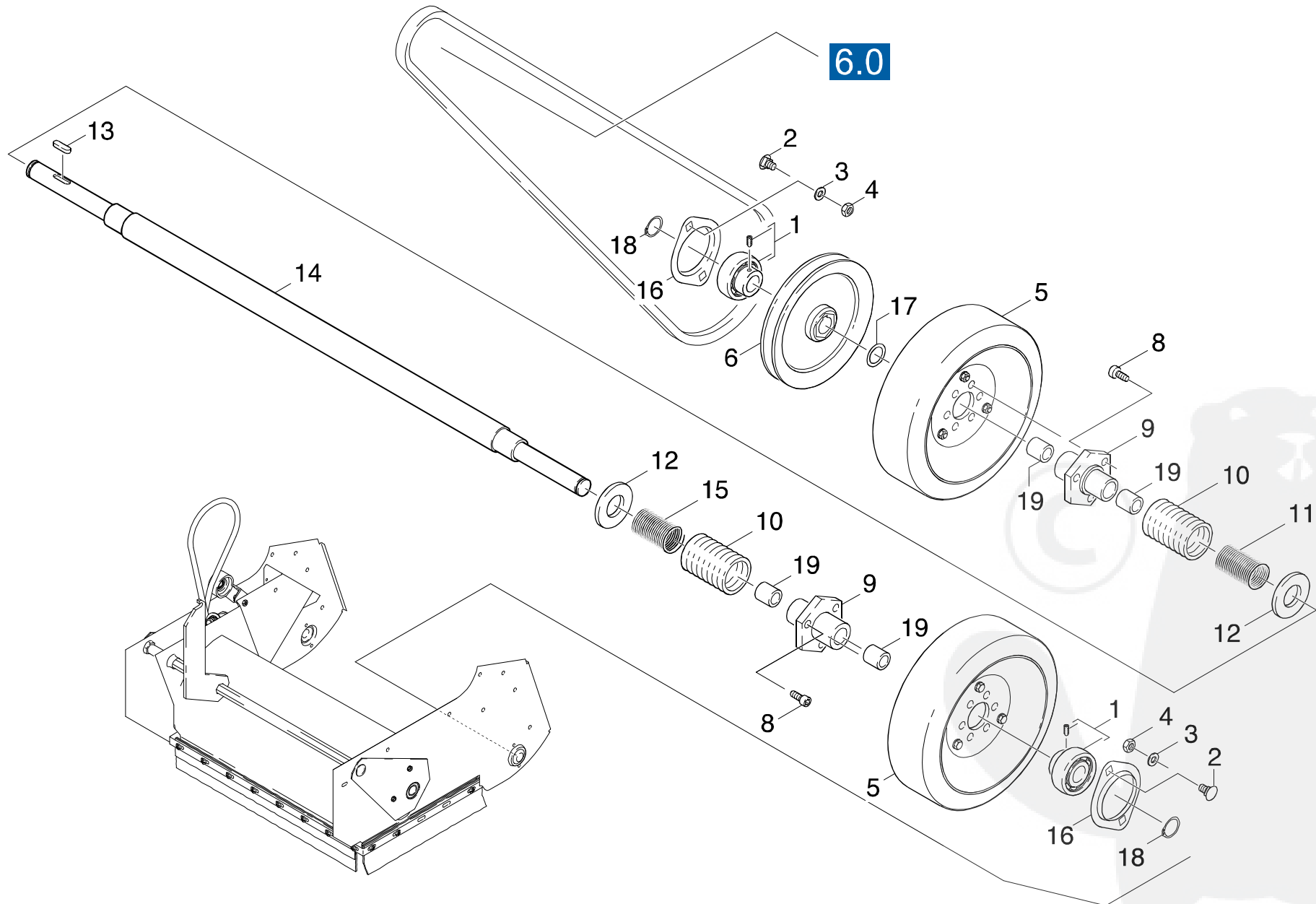

Symbolbeschreibung siehe M16 / symbol description see M16 / désignation de système voir M16 /

GRUPPE: 4.0 ANTRIEB
GROUP: 4.0 ACTUATION
GROUPE: 4.0 ENTRAINEMENT

C4

KSM 750 BAT

POS. ITM. POS.	BENNENNUNG DESCRIPTION DESIGNATION	TEILE-NR. PART-NO. NO.PIECE	STCK QTY. NBR.
1	SPANNLAGER / BEARING / PALIER	6.401-270.0	2
2	SCHRAUBE M 6X 12 / SCREW / VIS	7.303-046.0	4
3	SCHEIBE 6 / WASHER / RONDELLE	7.312-003.0	4
4	6KT-MUTTER M 6 / HEXAGON NUT / ECROU HEXAGONAL	7.311-003.0	4
5	RAD D160 KSM 750 P / WHEEL / ROUE	6.435-316.0	2
6	RIEMENSCHLEIBE / PULLEY / POULIE	5.625-277.0	1
8	ZYL.SCHR. M 6X 12 / CHEESE HEAD SCREW / VIS A TETE CYLINDR.	6.303-193.0	6
9	RADNABE / WHEEL HUB / MOYEU DE ROUE	5.515-100.0	2
10	SCHLAUCHSTUECK / HOSE / BOUT DE TUYAU	5.442-880.0	2
11	SCHRAUBENFEDER RE / HELICAL SPRING / RESSORT CYLINDRIQUE	5.332-378.0	1
12	SCHEIBE 20 / WASHER / RONDELLE	7.312-013.0	2
13	PASSFEDER 5X 5X 18 / SPRING / RESSORT D'ADJUSTAGE	7.318-003.0	1
14	ACHSE RAD / AXLE / ESSIEU	5.105-259.0	1
15	SCHRAUBENFEDER LI / HELICAL SPRING / RESSORT CYLINDRIQUE	5.332-377.0	1
16	FLANSCHGEHAEUSE / FLANGE HOUSING / BOITE DE BRIDE	6.401-271.0	2
17	PASSCHEI. 15X21X0,5 / WASHER / RONDELLE	7.343-217.0	1
18	S-SCHEIBE 12 / LOCK WASHER / RONDELLE D'ARRET	7.343-306.0	2
19	LAGERBUCHSE / BEARING BUSH / COUSSINET	6.437-480.0	4



"=> xxxxxx" = bis Werknummer / up to serial No. / jusqu' au No. de fabr. / "xxxxxx =>" = ab Werknummer / from serial No. / a partir du No. de fabr. /

GRUPPE: 5.0 ANTRIEB SEITENBESEN
GROUP: 5.0 ACTUATION
GRUPPE: 5.0 ENTRAINEMENT

A5

KSM 750 BAT

GRUPPE: 5.0 ANTRIEB SEITENBESEN
GROUP: 5.0 ACTUATION
GRUPPE: 5.0 ENTRAINEMENT

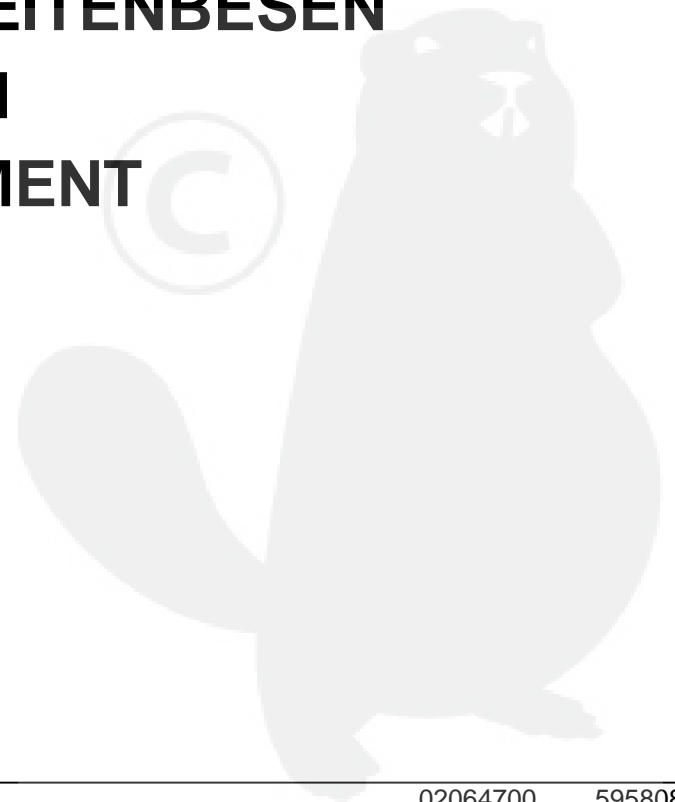

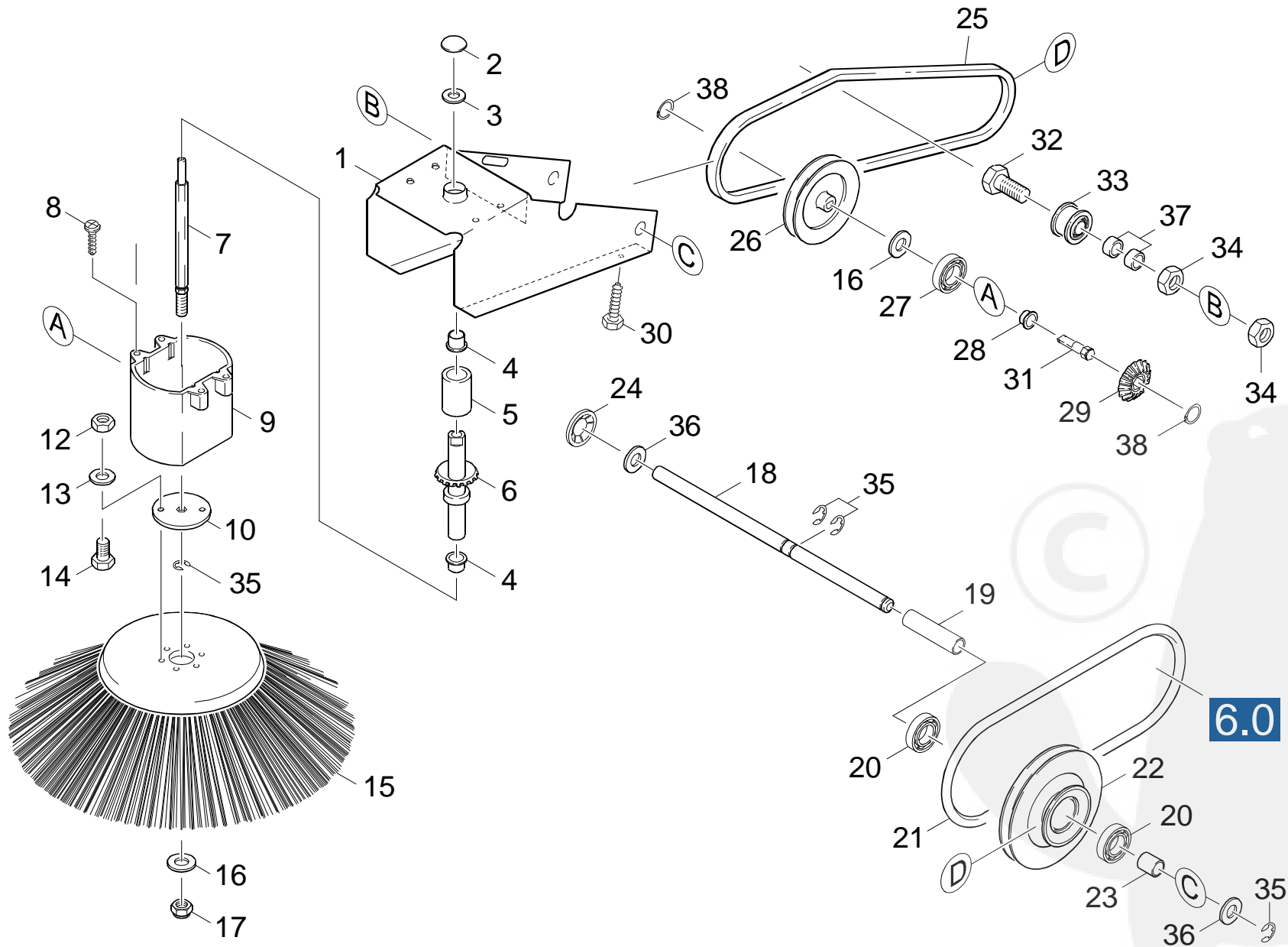

Symbolbeschreibung siehe M16 / symbol description see M16 / désignation de système voir M16 /

GRUPPE: 5.0 ANTRIEB SEITENBESEN
 GROUP: 5.0 ACTUATION
 GROUPE: 5.0 ENTRAITEMENT

C5

KSM 750 BAT

POS. ITM. POS.	BENNENNUNG DESCRIPTION DESIGNATION	TEILE-NR. PART-NO. NO.PIECE	STCK QTY. NBR.	POS. ITM. POS.	BENNENNUNG DESCRIPTION DESIGNATION	TEILE-NR. PART-NO. NO.PIECE	STCK QTY. NBR.
1	BLECHTEIL / PLATE / TOLE / => 16900	5.046-858.0	1	31	WELLE / SHAFT / ARBRE	5.100-186.0	1
1	BLECHTEIL / PLATE / TOLE 16901 =>	5.048-218.0	1	32	ZYL.SCHR. M 8X 45 / CHEESE HEAD SCREW / VIS A TETE CYLINDR.	7.306-049.0	1
2	SICHERUNGSSCHEIBE / LOCK WASHER / RONDELLE D'ARRET	6.343-129.0	1	33	UMLENKROLLE / DEFLECTION PULLEY / POULIE	6.435-274.0	1
3	SCHEIBE 6 / WASHER / RONDELLE	7.312-292.0	1	34	6KT-MUTTER M 8 / HEXAGON NUT / ECROU HEXAGONAL	7.311-004.0	2
4	LAGERBUCHSE / BEARING BUSH / COUSSINET	6.437-484.0	2	35	S-SCHEIBE 9 / LOCK WASHER / RONDELLE D'ARRET	7.343-205.0	4
5	HUELSE / SLEEVE / DOUILLE	5.110-591.0	1	36	SCHEIBE 12 / WASHER / RONDELLE	7.312-008.0	1
6	HOHLWELLE / HOLLOW SHAFT / ARBRE CREUX	5.100-109.0	1	37	DISTANZHUELSE / SPACER SLEEVE / ENTRETOISE	6.347-094.0	2
7	ACHSE - SEITENBESEN / AXLE / ESSIEU	5.105-179.0	1	38	S-RING 8X0,8 / SPRING CLIP / CIRCLIP	7.343-014.0	2
8	SCHRAUBE 5X16 / SCREW / VIS	6.303-155.0	4				
9	GEHAEUSE / HOUSING / BOITIER	5.060-553.0	1				
10	SCHEIBE / WASHER / RONDELLE	5.115-509.0	1				
12	6KT-MUTTER M 6 / HEXAGON NUT / ECROU HEXAGONAL	7.311-003.0	2				
13	SCHEIBE 6 / WASHER / RONDELLE	7.312-003.0	2				
14	SCHRAUBE M 6X 16 / SCREW / VIS	7.306-090.0	2				
15	SEITENBESEN MITTEL / SIDE BROOM / BALAI	6.951-073.0	1				
16	SCHEIBE 8 / WASHER / RONDELLE	7.312-004.0	2				
17	6KT-MUTTER M 8 / HEXAGON NUT / ECROU HEXAGONAL	7.311-427.0	1				
18	ACHSE SEITENARM / AXLE / ESSIEU	5.105-211.0	1				
19	HUELSE / SLEEVE / DOUILLE	5.110-581.0	1				
20	KUGELLAGER 6001-2RS / BALL BEARING / ROULEMENT A BILLE	7.401-111.0	2				
21	RUNDRIEMEN D8 / BELT / COURROIE RONDE	6.348-346.0	1				
22	RIEMENSCHLEIBE / PULLEY / POULIE	5.625-274.0	1				
23	HUELSE / SLEEVE / DOUILLE	5.110-580.0	1				
24	SCHNELLBEFESTIGER / QUICK-FASTENER / ATTACHE RAPIDE	6.343-180.0	1				
25	KEILRIEMEN X10 / LARGE V-BELT / COURROIE TRAPEZOID. / => 16900	6.348-285.0	1				
25	KEILRIEMEN / LARGE V-BELT / COURROIE TRAPEZOID. 16901 =>	6.348-324.0	1				
26	RIEMENSCHLEIBE / PULLEY / POULIE	5.625-332.0	1				
27	KUGELLAGER 628/8-2Z / BALL BEARING / ROULEMENT A BILLE	7.401-174.0	1				
28	LAGERBUCHSE / BEARING BUSH / COUSSINET	6.437-485.0	1				
29	RITZEL / PINION / PIGNON	5.352-060.0	1				
30	BL.SCHR. ST3,5X 9,5 / SHEET METAL SCREW / VIS A TOLE	7.303-361.0	1				



"=> xxxxxx" = bis Werknummer / up to serial No. / jusqu' au No. de fabr. / "xxxxxx =>" = ab Werknummer / from serial No. / a partir du No. de fabr. /

GRUPPE: 6.0 MOTOR
GROUP: 6.0 MOTOR
GRUPPE: 6.0 MOTEUR

A6

KSM 750 BAT

GRUPPE: 6.0 MOTOR
GROUP: 6.0 MOTOR
GRUPPE: 6.0 MOTEUR



GRUPPE: 6.1 MOTOR / (1.049-121.0) /
GROUP: 6.1 MOTOR / (1.049-121.0) /
GROUPE: 6.1 MOTEUR / (1.049-121.0) /

B6

KSM 750 BAT

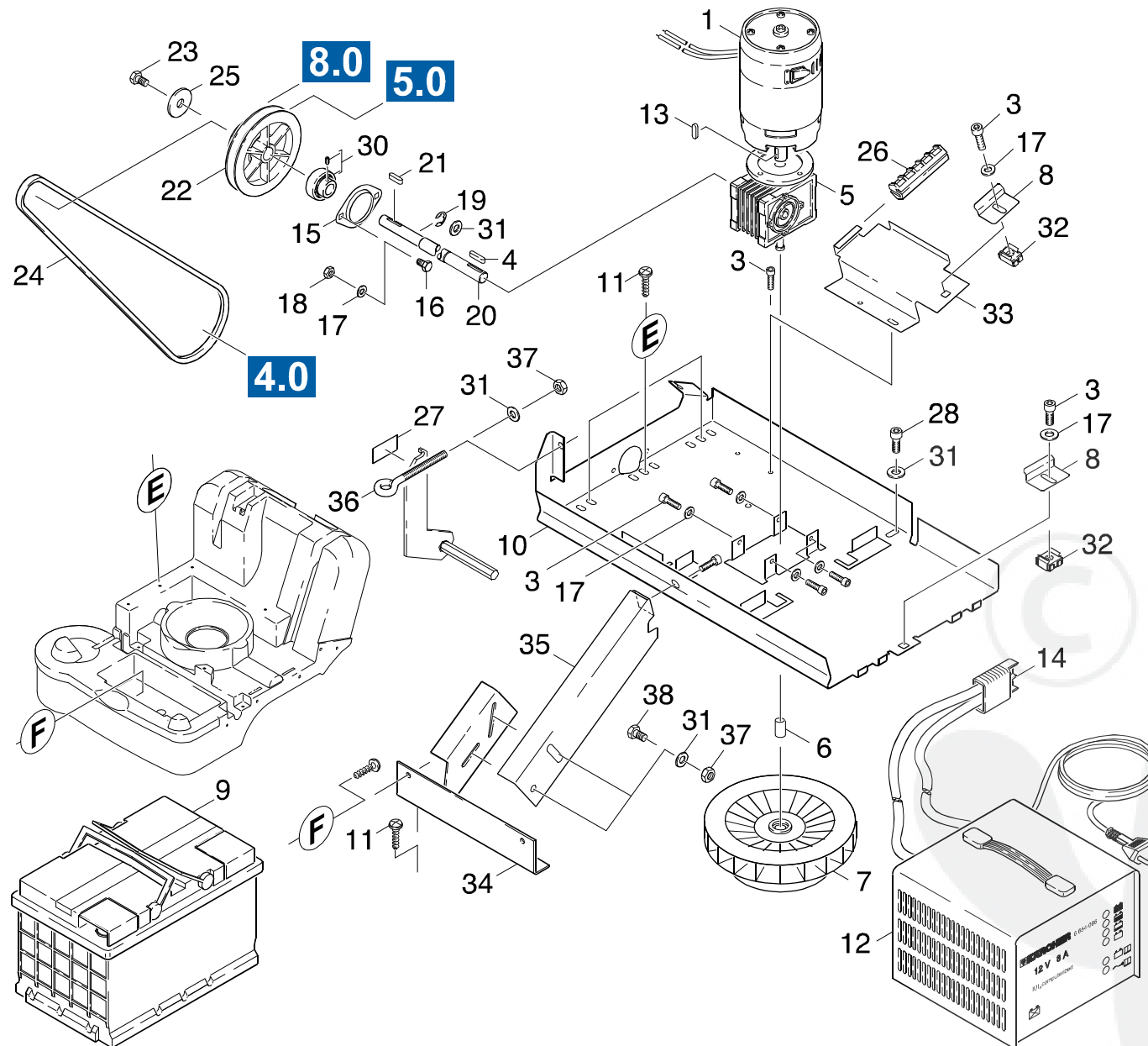

Symbolbeschreibung siehe M16 / symbol description see M16 / désignation de système voir M16 /

GRUPPE: 6.1 MOTOR / (1.049-121.0) /
 GROUP: 6.1 MOTOR / (1.049-121.0) /
 GROUPE: 6.1 MOTEUR / (1.049-121.0) /

C6

KSM 750 BAT

POS. ITM. POS.	BENNENNUNG DESCRIPTION DESIGNATION	TEILE-NR. PART-NO. NO.PIECE	STCK QTY. NBR.	POS. ITM. POS.	BENNENNUNG DESCRIPTION DESIGNATION	TEILE-NR. PART-NO. NO.PIECE	STCK QTY. NBR.
1	GLEICHSTROMMOTOR / DC MOTOR / MOTEUR C.C.	6.613-047.0	1	34	BLECHTEIL KPL. / PLATE / TOLE	4.038-612.0	1
3	ZYL.SCHR. M 6X 12 / CHEESE HEAD SCREW / VIS A TETE CYLINDR.	6.303-193.0	6		/ => 16669		
4	PASSFEDER 5X 5X 18 / SPRING / RESSORT D'ADJUSTAGE	7.318-003.0	1	35	BLECHTEIL / PLATE / TOLE	5.047-730.0	1
5	SCHNECKENGETRIEBE / WORM GEARING / ENGRENAGE A VIS	6.454-060.0	1		/ => 16669		
6	TOLERANZHUELSE D11 / TOLERANCE BUSH / DOUILLE DE TOL.	6.343-212.0	1	36	GEWINDEOSE / EAR / OEILLET	6.373-659.0	1
7	GEBLAESERAD / BLOWER WHEEL / ROUE DE VENTILATEUR	6.484-050.0	1	37	6KT-MUTTER M 8 / HEXAGON NUT / ECROU HEXAGONAL	7.311-427.0	1
8	HALTER / BRACKET / FIXATION	5.046-367.0	2	38	6KT-SCHR. M 8X 16 / HEXAGONAL HEAD SCREW / VIS HEXAGONAL	7.304-395.0	2
9	ANTRIEBSBATTERIE WF / BATTERY / BATTERIE	6.654-021.0	2		/ => 16669		
10	BLECHTEIL / PLATE / TOLE	5.047-685.0	1				
10	BLECHTEIL / PLATE / TOLE	5.048-194.0	1				
	16670 =>						
11	SCHRAUBE 6,0X20 / SCREW / VIS	6.303-174.0	5				
12	LADEGERAET 24V / BATTERY CHARGER / CHARGEUR	6.654-068.0	1				
13	PASSFEDER 4X 4X 20 / SPRING / RESSORT D'ADJUSTAGE	7.318-058.0	1				
14	STECKER 50A-2POL / PLUG / FICHE	6.646-345.0	1				
15	FLANSCHGEHAEUSE / FLANGE HOUSING / BOITE DE BRIDE	6.401-271.0	2				
16	SCHRAUBE M 6X 16 / SCREW / VIS	7.306-090.0	2				
17	SCHEIBE 6 / WASHER / RONDELLE	7.312-003.0	9				
18	6KT-MUTTER M 6 / HEXAGON NUT / ECROU HEXAGONAL	7.311-003.0	2				
19	S-SCHEIBE 12 / LOCK WASHER / RONDELLE D'ARRET	7.343-306.0	1				
20	WELLE / SHAFT / ARBRE	5.100-234.0	1				
21	PASSFEDER A 5X5X 25 / SPRING / RESSORT D'ADJUSTAGE	7.318-079.0	1				
22	RIEMENSCHLEIBE / PULLEY / POULIE	5.625-455.0	1				
23	6KT-SCHR. M 5X 16 / HEXAGONAL HEAD SCREW / VIS HEXAGONAL	7.304-372.0	1				
24	KEILRIEMEN Z/10 / LARGE V-BELT / COURROIE TRAPEZOID.	6.348-313.0	1				
25	SCHEIBE / WASHER / RONDELLE	5.115-233.0	1				
26	ADAPTER B3 / ADAPTER / ADAPTATEUR	5.031-161.0	1				
27	SCHILD / LABEL / PLAQUE	5.382-465.0	1				
28	ZYL.SCHR. M 8X 20 / CHEESE HEAD SCREW / VIS A TETE CYLINDR.	7.306-041.0	1				
30	SPANNLAGER / BEARING / PALIER	6.401-270.0	1				
31	SCHEIBE 8 / WASHER / RONDELLE	7.312-004.0	2				
32	KAFIGMUTTER M 6 / NUT / ECROU	6.310-020.0	2				
33	HALTER / BRACKET / FIXATION	5.044-053.0	1				



"=> xxxxxx" = bis Werknummer / up to serial No. / jusqu' au No. de fabr. / "xxxxxx =>" = ab Werknummer / from serial No. / a partir du No. de fabr. /

GRUPPE: 6.2 MOTOR / (1.049-684.0) /
GROUP: 6.2 MOTOR / (1.049-684.0) /
GROUPE: 6.2 MOTEUR / (1.049-684.0) /

E6

KSM 750 BAT

POS. ITM. POS.	BENNENUNG DESCRIPTION DESIGNATION	TEILE-NR. PART-NO. NO.PIECE	STCK QTY. NBR.
1	GLEICHSTROMMOTOR / DC MOTOR / MOTEUR C.C.	6.613-026.0	1
3	ZYL.SCHR. M 6X 12 / CHEESE HEAD SCREW / VIS A TETE CYLINDR.	6.303-193.0	4
4	PASSFEDER 5X 5X 18 / SPRING / RESSORT D'ADJUSTAGE	7.318-003.0	1
5	SCHNECKENGETRIEBE / WORM GEARING / ENGRENAGE A VIS	6.454-060.0	1
6	TOLERANZHUELSE D11 / TOLERANCE BUSH / DOUILLE DE TOL.	6.343-212.0	1
7	GEBLAESERAD / BLOWER WHEEL / ROUE DE VENTILATEUR	6.484-050.0	1
8	6KT-MUTTER M 8 / HEXAGON NUT / ECROU HEXAGONAL	7.311-427.0	3
9	GEWINDEOSE / EAR / OEILLET	6.373-659.0	1
10	BLECHTEIL / PLATE / TOLE	5.047-685.0	1
11	SCHRAUBE 6,0X20 / SCREW / VIS	6.303-174.0	9
13	PASSFEDER 4X 4X 20 / SPRING / RESSORT D'ADJUSTAGE	7.318-058.0	1
15	FLANSCHGEHAEUSE / FLANGE HOUSING / BOITE DE BRIDE	6.401-271.0	2
16	SCHRAUBE M 6X 16 / SCREW / VIS	7.306-090.0	2
17	SCHEIBE 6 / WASHER / RONDELLE	7.312-003.0	6
18	6KT-MUTTER M 6 / HEXAGON NUT / ECROU HEXAGONAL	7.311-003.0	2
19	S-SCHEIBE 12 / LOCK WASHER / RONDELLE D'ARRET	7.343-306.0	1
20	WELLE / SHAFT / ARBRE	5.100-181.0	1
21	TOLERANZRING BN15 / TOLERANCE RING / BAGUE	6.343-195.0	2
22	RIEMENSCHLEIBE / PULLEY / POULIE	5.625-276.0	1
24	KEILRIEMEN Z/10 / LARGE V-BELT / COURROIE TRAPEZOID.	6.348-282.0	1
25	SCHRAUBE 5X16 / SCREW / VIS	6.303-155.0	4
26	BLECHTEIL / PLATE / TOLE	5.047-366.0	1
27	SCHILD / LABEL / PLAQUE	5.382-465.0	1
28	ZYL.SCHR. M 8X 20 / CHEESE HEAD SCREW / VIS A TETE CYLINDR.	7.306-041.0	1
30	SPANNLAGER / BEARING / PALIER	6.401-270.0	1
31	SCHEIBE 8 / WASHER / RONDELLE	7.312-004.0	2
32	BLECHTEIL / PLATE / TOLE	5.047-330.0	1
33	BLECHTEIL / PLATE / TOLE	5.047-898.0	1
35	SCHRAUBE M 6X 12 / SCREW / VIS	7.303-046.0	2
36	KLETTENBAND / TAPE / RUBAN CRAMPON	6.369-268.0	1
37	KANTENSCHUTZ / SHEATING / BORD DE PROTECTION	5.364-212.0	2
38	SCHUTZTEIL / PROTECTION PART / PARTIE PROTECTEUR	5.394-164.0	1



"=> xxxxxx" = bis Werknummer / up to serial No. / jusqu' au No. de fabr. / "xxxxxx =>" = ab Werknummer / from serial No. / a partir du No. de fabr. /

GRUPPE: 7.0 KEHRWALZENKASTEN
GROUP: 7.0 SWEEP ROLLER CHEST
GRUPPE: 7.0 COFFRE DE CYLINDR.BALAYER

A7

KSM 750 BAT

GRUPPE: 7.0 KEHRWALZENKASTEN
GROUP: 7.0 SWEEP ROLLER CHEST
GRUPPE: 7.0 COFFRE DE CYLINDR.BALAYER



GRUPPE: 7.1 KEHRWALZENKASTEN / VERSION 1 /
GROUP: 7.1 SWEEP ROLLER CHEST / VERSION 1 /
GRUPPE: 7.1 COFFRE DE CYLINDR.BALAYER / VERSION 1 /

B7

KSM 750 BAT

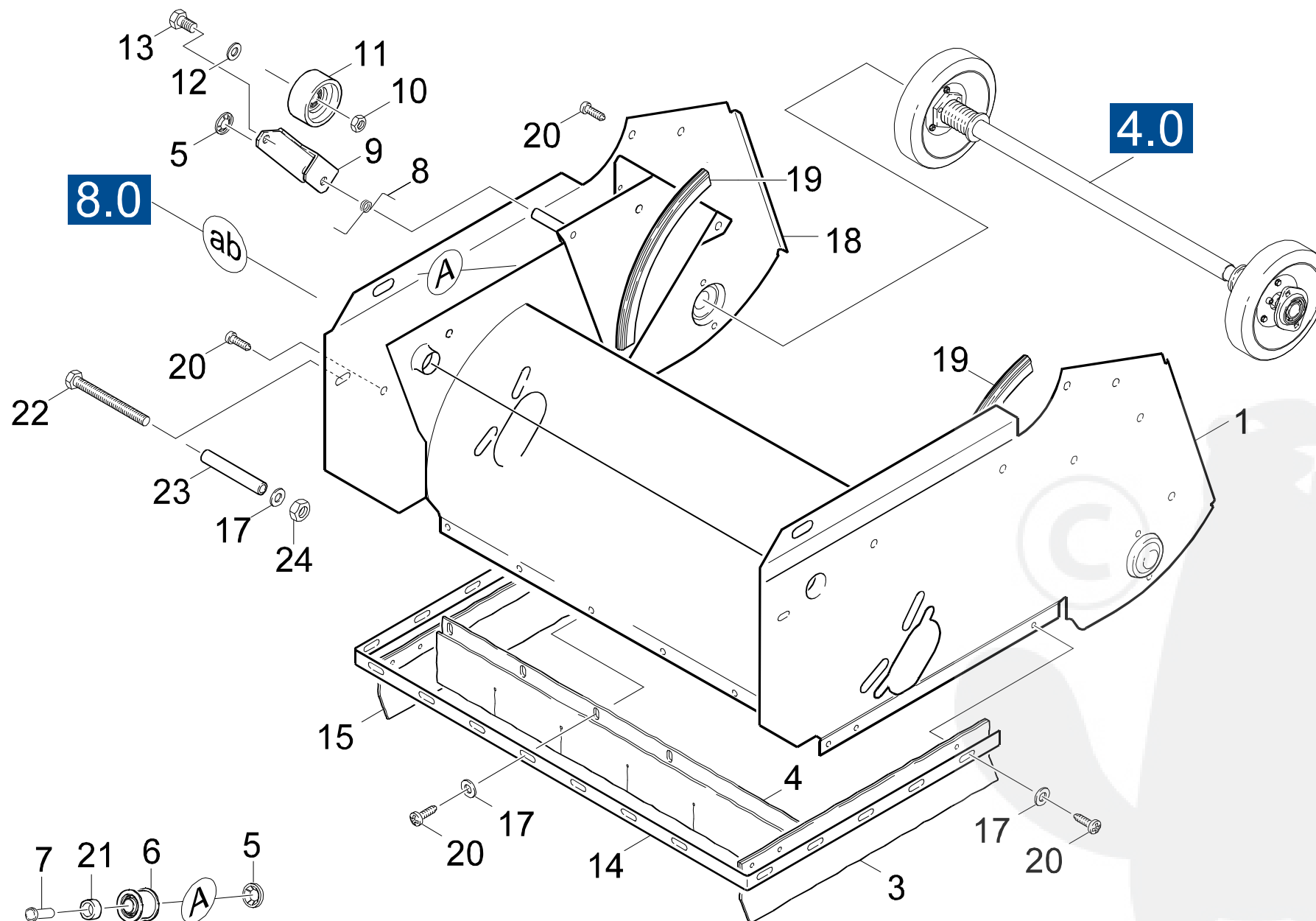

Symbolbeschreibung siehe M16 / symbol description see M16 / désignation de système voir M16 /

GRUPPE: 7.1 KEHRWALZENKASTEN / VERSION 1 /
 GROUP: 7.1 SWEEP ROLLER CHEST / VERSION 1 /
 GROUPE: 7.1 COFFRE DE CYLINDR.BALAYER / VERSION 1 /

C7

KSM 750 BAT

POS. ITM. POS.	BENNENNUNG DESCRIPTION DESIGNATION	TEILE-NR. PART-NO. NO.PIECE	STCK QTY. NBR.
1	KEHRWALZENKASTEN / SWEEP ROLLER CHEST / COFFRE DE CYLINDR.BALAYER	4.038-621.0	1
3	DICHTLIPPE LINKS / SEAL / JOINT	6.365-411.0	1
4	DICHTLIPPE MITTE / SEAL / JOINT	6.365-442.0	1
5	SCHNELLBEFESTIGER / QUICK-FASTENER / ATTACHE RAPIDE	6.343-147.0	2
6	UMLENKROLLE / DEFLECTION PULLEY / POULIE	6.435-274.0	1
7	BOLZEN / BOLT / BOULON	5.316-294.0	1
8	BIEGEFEDER / SPIRAL SPRING / RESSORT SPIRAL	5.332-400.0	1
9	BLECHTEIL / PLATE / TOLE	5.046-903.0	1
10	6KT-MUTTER M 8 / HEXAGON NUT / ECROU HEXAGONAL	7.311-004.0	1
11	ROLLE / ROLLER / ROULETTE	5.515-092.0	1
12	SCHEIBE 8 / WASHER / RONDELLE	7.312-004.0	1
13	6KT-SCHR. M 8X 25 / HEXAGONAL HEAD SCREW / VIS HEXAGONAL	7.304-399.0	1
14	LEISTE / STRIP / BAGUETTE	5.047-663.0	1
15	DICHTLIPPE RECHTS / SEAL / JOINT	6.365-412.0	1
17	SCHEIBE 6 / WASHER / RONDELLE	7.312-003.0	14
18	ABDECKBLECH RECHTS / COVER PLATE / TOLE DE PROTECTION	5.048-471.0	1
19	DICHTUNG / SEAL / BOURRAGE	5.364-192.0	2
20	SCHRAUBE M 6X 12 / SCREW / VIS	7.303-046.0	13
21	DISTANZHUELSE / SPACER SLEEVE / ENTRETOISE	6.347-094.0	1
22	SCHRAUBE M 6X 60 / SCREW / VIS	7.306-138.0	1
23	DISTANZHUELSE / SPACER SLEEVE / ENTRETOISE	5.110-747.0	1
24	6KT-MUTTER M 6 / HEXAGON NUT / ECROU HEXAGONAL	7.311-003.0	1



"=> xxxxxx" = bis Werknummer / up to serial No. / jusqu' au No. de fabr. / "xxxxxx =>" = ab Werknummer / from serial No. / a partir du No. de fabr. /

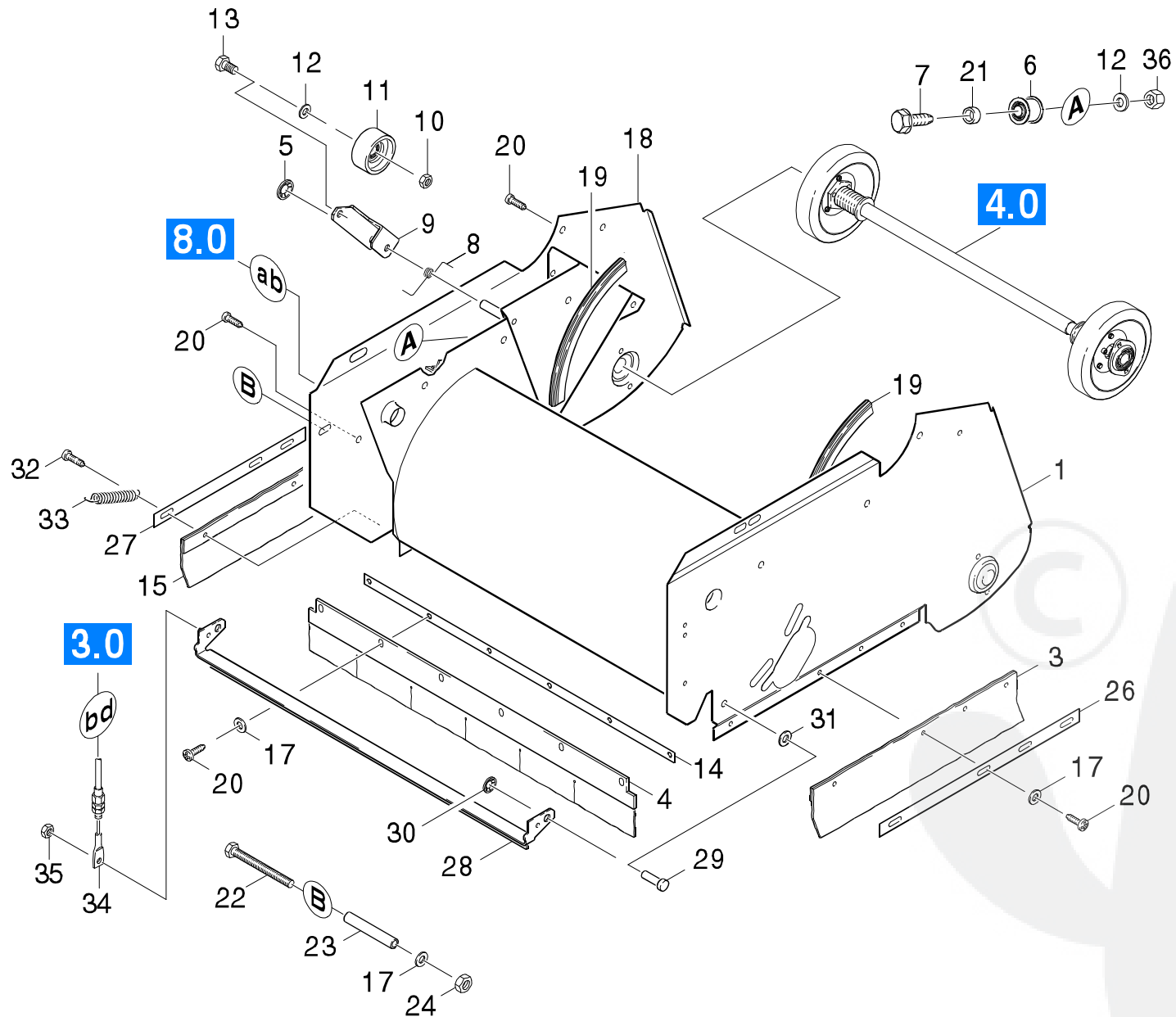

Symbolbeschreibung siehe M16 / symbol description see M16 / désignation de système voir M16 /

GRUPPE: 7.2 KEHRWALZENKASTEN / VERSION 2 /
 GROUP: 7.2 SWEEP ROLLER CHEST / VERSION 2 /
 GROUPE: 7.2 COFFRE DE CYLINDR.BALAYER / VERSION 2 /

E7

KSM 750 BAT

POS. ITM. POS.	BENNENUNG DESCRIPTION DESIGNATION	TEILE-NR. PART-NO. NO.PIECE	STCK QTY. NBR.
1	KEHRWALZENKASTEN / SWEEP ROLLER CHEST / COFFRE DE CYLINDR.BALAYER	4.038-788.0	1
3	DICHTLIPPE LINKS / SEAL / JOINT	6.365-411.0	1
4	DICHTLIPPE MITTE / SEAL / JOINT	6.365-454.0	1
5	SCHNELLBEFESTIGER / QUICK-FASTENER / ATTACHE RAPIDE	6.343-147.0	1
6	UMLENKROLLE / DEFLECTION PULLEY / POULIE	6.435-274.0	1
7	SCHRAUBE M 8X 25 / SCREW / VIS	7.306-221.0	1
8	BIEGEFEDER / SPIRAL SPRING / RESSORT SPIRAL	5.332-400.0	1
9	BLECHTEIL / PLATE / TOLE	5.046-903.0	1
10	6KT-MUTTER M 8 / HEXAGON NUT / ECROU HEXAGONAL	7.311-004.0	1
11	ROLLE / ROLLER / ROULETTE	5.515-092.0	1
12	SCHEIBE 8 / WASHER / RONDELLE	7.312-004.0	2
13	6KT-SCHR. M 8X 25 / HEXAGONAL HEAD SCREW / VIS HEXAGONAL	7.304-399.0	1
14	LEISTE VORNE / STRIP / BAGUETTE	5.190-136.0	1
15	DICHTLIPPE RECHTS / SEAL / JOINT	6.365-412.0	1
17	SCHEIBE 6 / WASHER / RONDELLE	7.312-003.0	14
18	ABDECKBLECH RECHTS / COVER PLATE / TOLE DE PROTECTION	5.048-471.0	1
19	DICHTUNG / SEAL / BOURRAGE	5.364-192.0	2
20	SCHRAUBE M 6X 12 / SCREW / VIS	7.303-046.0	13
21	DISTANZHUELSE / SPACER SLEEVE / ENTRETOISE	6.347-094.0	1
22	SCHRAUBE M 6X 60 / SCREW / VIS	7.306-138.0	1
23	DISTANZHUELSE / SPACER SLEEVE / ENTRETOISE	5.110-747.0	1
24	6KT-MUTTER M 6 / HEXAGON NUT / ECROU HEXAGONAL	7.311-003.0	1
26	LEISTE LINKS / STRIP / BAGUETTE	5.190-134.0	1
27	LEISTE RECHTS / STRIP / BAGUETTE	5.190-135.0	1
28	BLECHTEIL KPL. / PLATE / TOLE	4.038-787.0	1
29	BOLZEN B 10,0X 14 / BOLT / BOULON	7.316-214.0	1
30	SCHNELLBEFESTIGER / QUICK-FASTENER / ATTACHE RAPIDE	6.343-149.0	1
31	SCHEIBE 10 / WASHER / RONDELLE	7.312-074.0	1
32	SCHRAUBE M 6X 25 / SCREW / VIS	7.303-049.0	1
33	ZUGFEDER / EXTENSION SPRING / RESSORT DE TRACTION	6.330-056.0	1
34	BOWDENZUG KPL. / BOWDEN WIRE / CABLE SOUS GAINÉ	6.431-198.0	1
35	6KT-MUTTER M 5 / HEXAGON NUT / ECROU HEXAGONAL	7.311-431.0	1
36	6KT-MUTTER M 8 / HEXAGON NUT / ECROU HEXAGONAL	7.311-427.0	1



"=> xxxxxx" = bis Werknummer / up to serial No. / jusqu' au No. de fabr. / "xxxxxx =>" = ab Werknummer / from serial No. / a partir du No. de fabr. /

GRUPPE: 8.0 KEHRWALZE
GROUP: 8.0 REVERSING ROLLING MILL
GRUPPE: 8.0 TAMBOUR

A8

KSM 750 BAT

GRUPPE: 8.0 KEHRWALZE
GROUP: 8.0 REVERSING ROLLING MILL
GRUPPE: 8.0 TAMBOUR



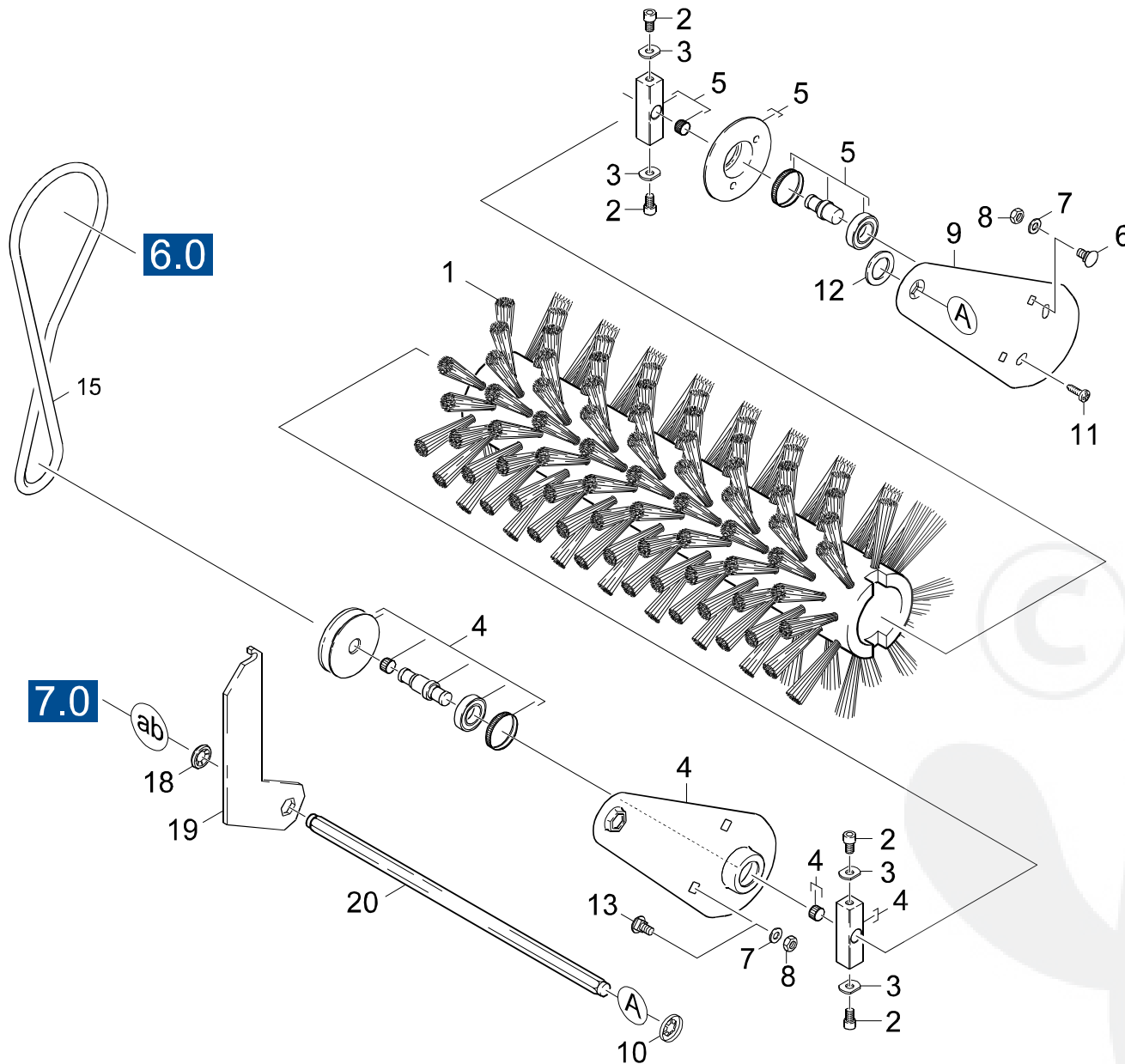

Symbolbeschreibung siehe M16 / symbol description see M16 / désignation de système voir M16 /

GRUPPE: 8.0 KEHRWALZE
GROUP: 8.0 REVERSING ROLLING MILL
GROUPE: 8.0 TAMBOUR

C8

KSM 750 BAT

POS. ITM. POS.	BENNENNUNG DESCRIPTION DESIGNATION	TEILE-NR. PART-NO. NO.PIECE	STCK QTY. NBR.
1	KEHRWALZE MITTEL / REVERSING ROLLING MILL / TAMBOUR	6.905-587.0	1
1	KEHRWALZE HART / REVERSING ROLLING MILL / TAMBOUR	6.905-868.0	1
1	KEHRWALZE WEICH-NAT / REVERSING ROLLING MILL / TAMBOUR	6.905-870.0	1
2	ZYL.SCHR. M 8X 20 / CHEESE HEAD SCREW / VIS A TETE CYLINDR.	7.306-041.0	4
3	BLECHTEIL / PLATE / TOLE	5.047-121.0	4
4	SCHWINGE RECHTS / LEVER / AICE	4.038-435.0	1
5	SCHWINGE LINKS / LEVER / AICE	4.038-448.0	1
6	FL.RD.SCHR. M 8X 20 / SAUCER-HEAD SCREW / BOULON A TETE BOMBEE	7.303-204.0	2
7	SCHEIBE 8 / WASHER / RONDELLE	7.312-277.0	4
8	6KT-MUTTER M 8 / HEXAGON NUT / ECROU HEXAGONAL	7.311-427.0	4
9	SCHWINGE LINKS / LEVER / AICE	5.046-859.0	1
10	SCHNELLBEFESTIGER / QUICK-FASTENER / ATTACHE RAPIDE	6.343-175.0	1
11	SCHRAUBE M 8X 20 / SCREW / VIS	7.303-068.0	2
12	SCHEIBE / WASHER / RONDELLE	6.312-069.0	1
13	FL.RD.SCHR. M 8X 16 / SAUCER-HEAD SCREW / BOULON A TETE BOMBEE	7.303-193.0	2
15	RUNDRIEMEN D10 / BELT / COURROIE RONDE	6.348-283.0	1
18	SCHNELLBEFESTIGER / QUICK-FASTENER / ATTACHE RAPIDE	6.343-202.0	1
19	BLECHTEIL / PLATE / TOLE	5.047-582.0	1
20	WELLE SCHWINGE / SHAFT / ARBRE	5.100-178.0	1



"=> xxxxxx" = bis Werknummer / up to serial No. / jusqu' au No. de fabr. / "xxxxxx =>" = ab Werknummer / from serial No. / a partir du No. de fabr. /

GRUPPE: 9.0 KEHRBEHAELTER
GROUP: 9.0 SWEEP TANK
GRUPPE: 9.0 BAC BALAYER

A9

KSM 750 BAT

GRUPPE: 9.0 KEHRBEHAELTER
GROUP: 9.0 SWEEP TANK
GRUPPE: 9.0 BAC BALAYER



GRUPPE: 9.0 KEHRBEHAELTER
GROUP: 9.0 SWEEP TANK
GRUPPE: 9.0 BAC BALAYER

B9

KSM 750 BAT

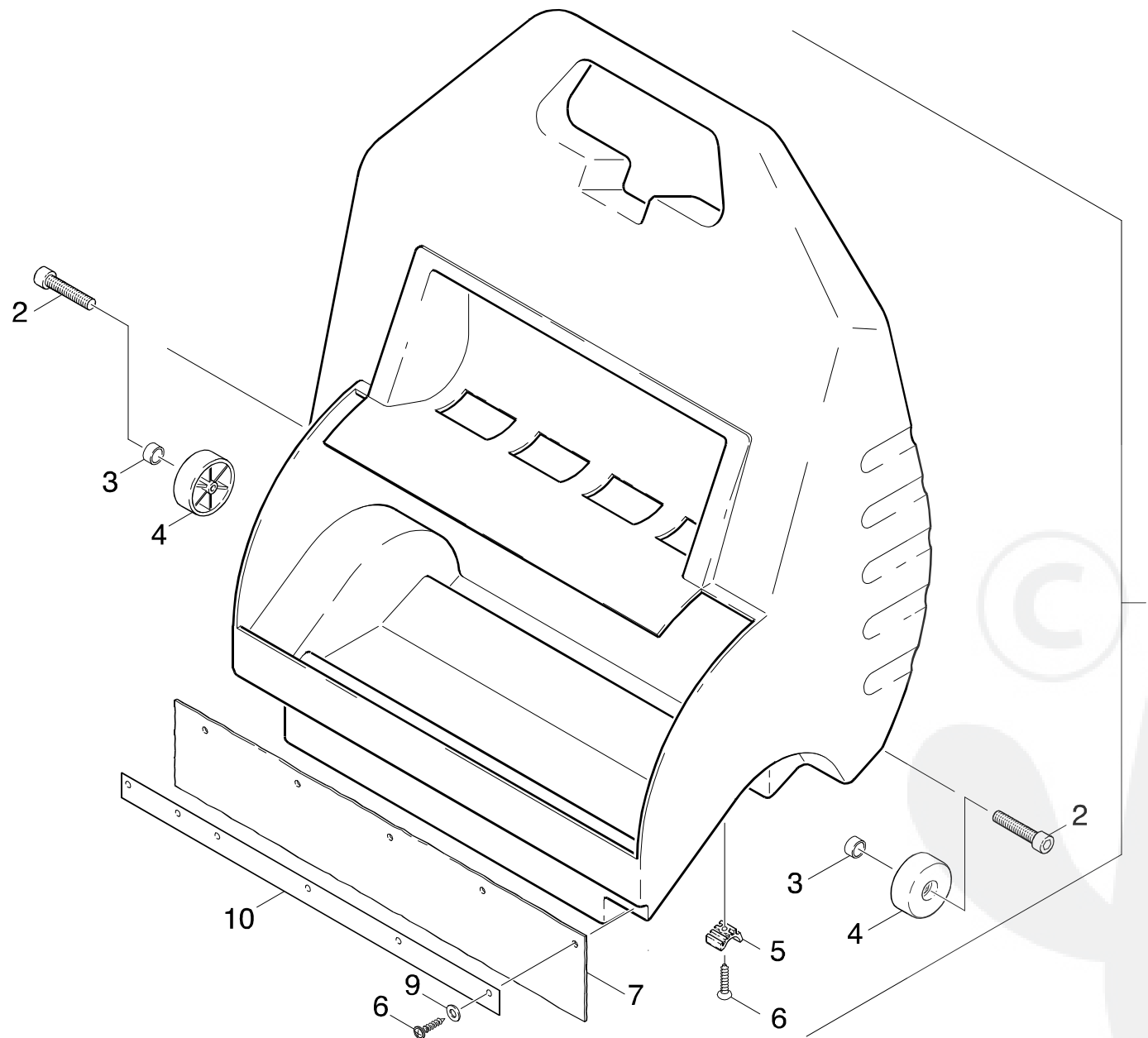

Symbolbeschreibung siehe M16 / symbol description see M16 / désignation de système voir M16 /

GRUPPE: 9.0 KEHRBEHAELTER
GROUP: 9.0 SWEEP TANK
GRUPPE: 9.0 BAC BALAYER

C9

KSM 750 BAT

POS.	BENNENUNG	TEILE-NR.	STCK
ITM.	DESCRIPTION	PART-NO.	QTY.
POS.	DESIGNATION	NO.PIECE	NBR.
1	KEHRBEHAELTER KPL. / SWEEP TANK / BAC BALAYER	4.070-217.0	1
2	SCHRAUBE M 6X 70 / SCREW / VIS	7.306-145.0	2
3	HUELSE / SLEEVE / DOUILLE	5.110-635.0	2
4	RAD / WHEEL / ROUE	5.515-068.0	2
5	GLEITSITZ / SLIDING / AJUSTEMENT	5.031-157.0	3
6	SENKSCHR. 5,0X 16 / FLAT HEADED SCREW / VIS A TETE CONIQUE	6.303-057.0	9
7	DICHTLIPPE HINTEN / SEAL / JOINT	6.365-395.0	1
9	SCHEIBE 6 / WASHER / RONDELLE	7.312-291.0	6
10	LEISTE KEHRBEH. / STRIP / BAGUETTE	5.031-847.0	1



"=> xxxxxx" = bis Werknummer / up to serial No. / jusqu' au No. de fabr. / "xxxxxx =>" = ab Werknummer / from serial No. / a partir du No. de fabr. /

GRUPPE: 10.0RUETTLER
GROUP: 10.0VIBRATOR
GRUPPE: 10.0VIBREUR

A10

KSM 750 BAT

**GRUPPE: 10.0RUETTLER
GROUP: 10.0VIBRATOR
GRUPPE: 10.0VIBREUR**

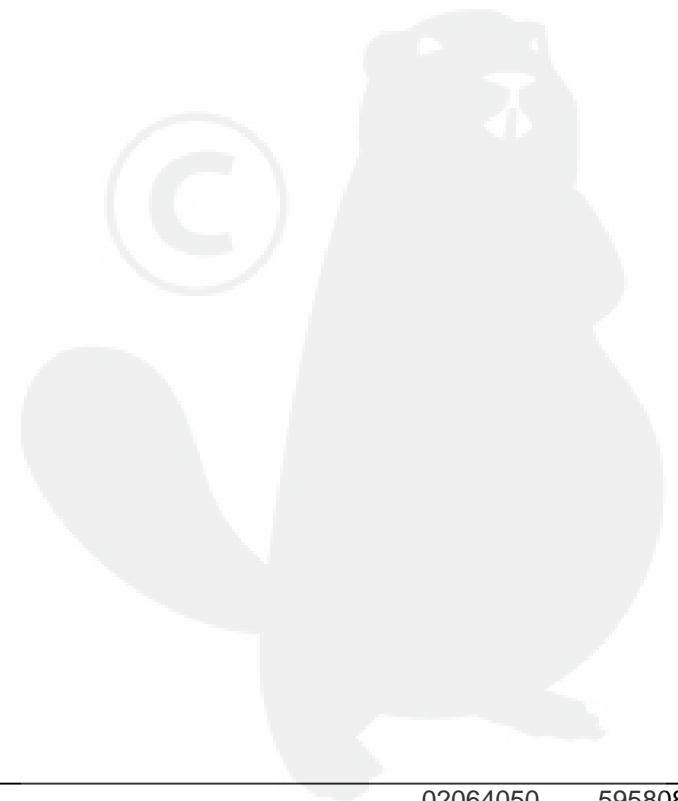

GRUPPE: 10.0RUETTLER
GROUP: 10.0VIBRATOR
GRUPPE: 10.0VIBREUR

B10

KSM 750 BAT

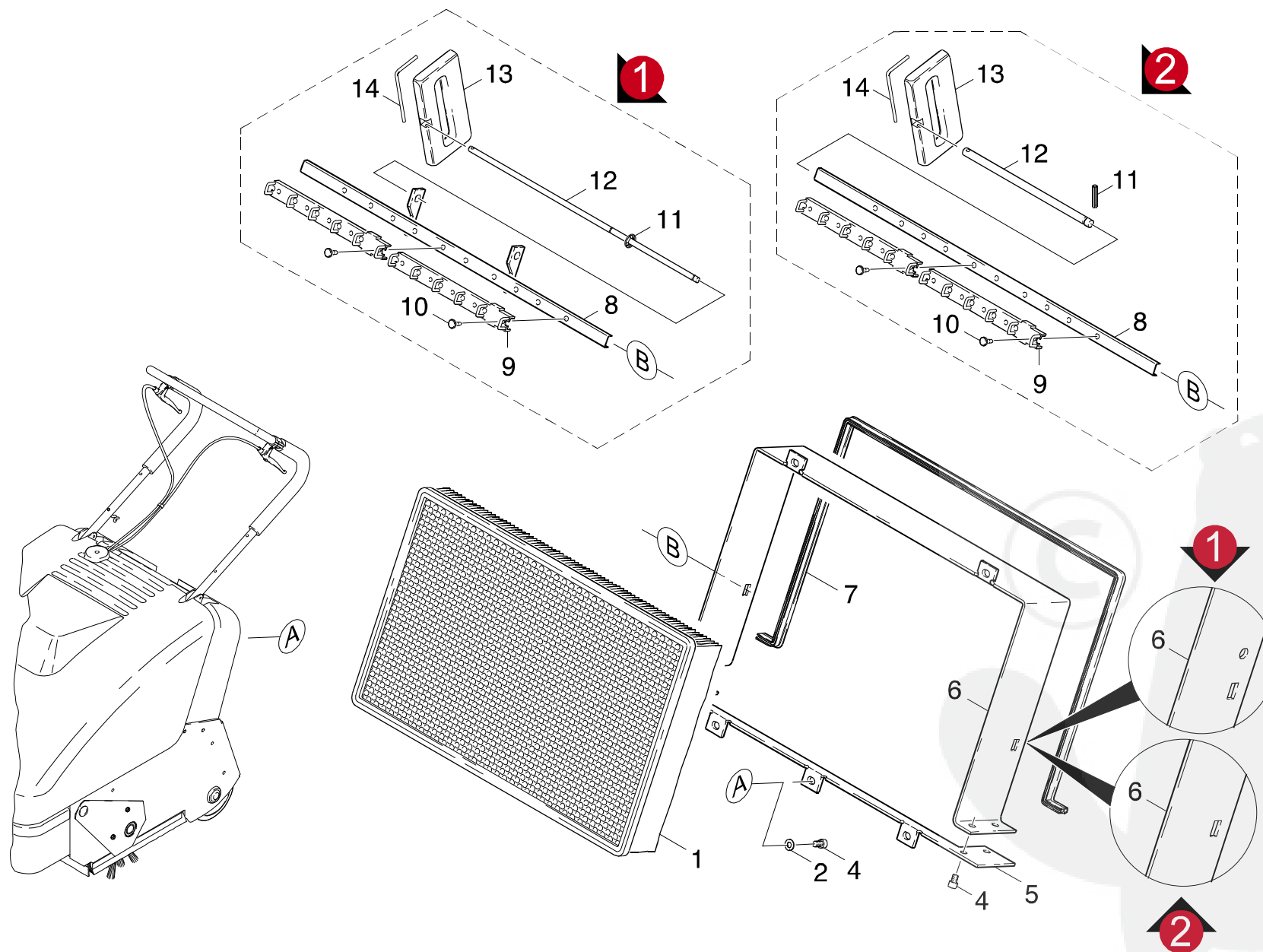

Symbolbeschreibung siehe M16 / symbol description see M16 / désignation de système voir M16 /

GRUPPE: 10.0RUETTLER
GROUP: 10.0VIBRATOR
GROUPE: 10.0VIBREUR

C10

KSM 750 BAT

POS. ITM. POS.	BENNENNUNG DESCRIPTION DESIGNATION	TEILE-NR. PART-NO. NO.PIECE	STCK QTY. NBR.
1	FILTER / FILTER / FILTRE	5.731-585.0	1
2	SCHEIBE 6 / WASHER / RONDELLE	7.312-003.0	5
4	ZYL.SCHR. M 6X 12 / CHEESE HEAD SCREW / VIS A TETE CYLINDR.	6.303-193.0	9
5	BLECHTEIL / PLATE / TOLE	5.046-971.0	1
6	BLECHTEIL / PLATE / TOLE	5.046-850.0	1
	VERSION 1		
6	BLECHTEIL / PLATE / TOLE	5.048-137.0	1
	VERSION 2		
7	DICHTUNG / SEAL / BOURRAGE	5.364-170.0	1
8	SCHIEBER / BOLT / VERROU	4.038-451.0	1
	VERSION 1		
8	U-PROFIL / U-PROFILE / PROFILE EN U	5.023-355.0	1
	VERSION 2		
9	ABSTREIFER / STRIPPER / DEVETISSEUR	5.030-900.0	2
10	NIET / RIVET / RIVET	6.315-068.0	10
11	SPLINT 3,2X 20 / COTTER / GOUPILLE FENDUE	7.316-342.0	1
	VERSION 2		
11	S-SCHEIBE 8 / LOCK WASHER / RONDELLE D'ARRET	7.343-302.0	2
	VERSION 1		
12	STANGE / BAR / TIGE	5.107-162.0	1
	VERSION 1		
12	STANGE / BAR / TIGE	5.107-199.0	1
	VERSION 2		
13	GRIFF / HANDLE / POIGNEE	5.321-115.0	1
14	HAKEN / HOOK / PATERE	5.037-061.0	1



"=> xxxxxx" = bis Werknummer / up to serial No. / jusqu' au No. de fabr. / "xxxxxx =>" = ab Werknummer / from serial No. / a partir du No. de fabr. /

Bestellhinweis

Bei Ihrer Bestellung sind unbedingt anzugeben :

1.	2.	3.	4.	5.
Gerätetyp Machine model Type d'appareils	Herstell-Nr. Serial-No. No. de série	Benennung Description Désignation	Teile-Nr. Part No. Référence	Stückzahl Piece No. Quantité



**siehe Typenschild
see name-plate
voir plaque signalétique**



**siehe Ersatzteilliste
see spare parts list
voir liste des pièces de rechange**

- Die Ersatzteile, welche als Meterware geliefert werden, sind auf Einbaulänge selbst zu kürzen. Ebenso sind die Stückzahlen in den jeweiligen Gruppen als Mindestbestellmengen = 1m angegeben und können je nach Bedarf auf weitere volle Meterzahlen erhöht und bestellt werden.
- Spare Parts which are delivered as cut goods have to be shortened to installation length. The quotation of quantity in each group refers to the minimum order quantity = 1m and may be ordered and raised to further full metre-values according to demand
- Les pièces de rechange qui sont livrées comme marchandise au mètre sont à raccourcir selon la longueur d'installation. Les indications de quantité dans chaque group se réfèrent à des valeurs de mètre de plus.
- Diese Ersatzteilliste erscheint in gedruckter Form sowie als Mikrofiche. Bei Querverweisen bezieht sich die Angabe "Seitenzahl" auf die gedruckte Ersatzteilliste und die Angabe "Bildtafel" auf die Mikrofichenausgabe.
- This spare parts list is published both in printed form and as a microfiche. In the cross-references, "page number" refers to the printed spare parts list and "display table" to the microfilm edition.
- Cette liste de pièces de rechange est aussi bien imprimée que publiée sous forme de microfiche. Les indications transversales renvoient au "numéro de page" sur la liste imprimée des pièces de rechange et à la "planche" sur la microfiche.

Bitte beachten Sie, daß der Teileumfang dieser Ersatzteilliste nicht unbedingt dem Lieferumfang Ihres Gerätes entspricht.

For your information: It could be that certain parts quoted in this spare parts list were not included with the machine delivery.

Pour votre information: il se peut que certaines pièces détachées mentionnées sur la liste ne vous aient pas été livrées avec l'appareil.

Die in dieser Ersatzteilliste nicht aufgeführten Einzelteile, bestellen Sie bitte direkt beim Vertragskundendienst des jeweiligen Herstellers.

Please order the individual parts not included in this assembly directly with the contract aftersales service of the manufacturer in question.

Veillez s'il vous plaît, commander les pièces détachées qui ne sont indiquées dans notre liste des pièces détachées, directement auprès du service après-vente des fabricants en question.

Bei Bestellung von lackierten Teilen, welche in der Ersatzteilliste nicht in verschiedenen Farben ausgewiesen sind, ist zusätzlich die Farbnummer oder Farbe mit anzugeben. Diese finden Sie auf dem Typenschild oder Farbschild Ihres Gerätes.

Upon ordering of varnished parts which are not mentioned in the spare parts list as parts with different colors, kindly additionally mention the number of the color. It can be seen on the type plate of the color plate of your machine.

Commandant des parts vernissés qui ne sont pas mentionnés comme parts avec une couleur différente dans la liste des pièces détachées, veuillez mentionner de plus le numéro de la couleur. Il se trouve sur la plaque signalétique ou la plaque de couleur de votre machine.

Auflistungen von Einzelteilen bei Ersatzteil - u. Pumpensets sind in der Reihe "16" einzusehen, bzw. direkt unter dem entsprechenden Set aufgelistet.

Listings of single parts upon spare parts kits and pump kits can be seen in row "16" or directly listed below the corresponding kit.
Des établissements des pièces détachées en ce qui concerne les kits des pièces de rechange et les kits de pompes, peuvent être vus à la ligne "16" ou ils sont répertoriés directement au-dessous du jeu correspondant.

Technische Änderungen im Rahmen der Weiterentwicklung sowie das Recht der ausschließlichen Auswertung unseres geistigen Eigentums behalten wir uns vor. Vervielfältigung und Nachdruck nur mit Genehmigung und Urheberhinweis möglich.

We reserve the right to make technical changes in the course of development work and the right to make exclusive use of our intellectual property. This spare parts list may be duplicated or reprinted only with our approval and with acknowledgement of our copyright.

Nous nous réservons le droit de toutes modifications techniques dans le cadre du perfectionnement des mises au point ainsi que le droit de la mise en valeur exclusive de notre propriété intellectuelle. Polycopie et reproduction exclusivement après accord et avec mention de l'auteur.

INDEX

M16

KSM 750 BAT

GRUPPE: 1.0 GRUNDRAHMEN A1-C1
GROUP: 1.0 BASE FRAME
GROUPE: 1.0 CADRE

GRUPPE: 2.0 HAUBE A2-C2
GROUP: 2.0 COVER
GROUPE: 2.0 CAPOT

GRUPPE: 3.0 SCHUBBUEGEL A3-C3
GROUP: 3.0 SHEARING SHACKLE
GROUPE: 3.0 L'ARCHET DE POUSEE

GRUPPE: 4.0 ANTRIEB A4-C4
GROUP: 4.0 ACTUATION
GROUPE: 4.0 ENTRAINEMENT

GRUPPE: 5.0 ANTRIEB SEITENBESEN A5-C5
GROUP: 5.0 ACTUATION
GROUPE: 5.0 ENTRAINEMENT

GRUPPE: 6.0 MOTOR A6-E6
GROUP: 6.0 MOTOR
GROUPE: 6.0 MOTEUR

GRUPPE: 7.0 KEHRWALZENKASTEN A7-E7
GROUP: 7.0 SWEEP ROLLER CHEST
GROUPE: 7.0 COFFRE DE CYLINDR.BALAYER

GRUPPE: 8.0 KEHRWALZE A8-C8
GROUP: 8.0 REVERSING ROLLING MILL
GROUPE: 8.0 TAMBOUR

GRUPPE: 9.0 KEHRBEHAELTER A9-C9
GROUP: 9.0 SWEEP TANK
GROUPE: 9.0 BAC BALAYER

GRUPPE: 10.0RUETTLER A10-C10
GROUP: 10.0VIBRATOR
GROUPE: 10.0VIBREUR

 BEISPIEL: VERSION 1
EXAMPLE: VERSION 1
EXEMPLE: VERSION 1

 BEISPIEL: SIEHE IN GRUPPE 3
EXAMPLE: SEE IN GROUP 3
EXEMPLE: VOIR EN GROUPE 3



WICHTIGER HINWEIS
IMPORTANT REMARK
REMARCAQUAGE IMPORTANT

BESTELLHINWEIS SIEHE M15
EXAMPLE ORDER SEE M15
EXEMPLE DE COMMANDE VOIR M15

VARIANTENÜBERSICHT SIEHE L16
VARIANTS SURVEY SEE L16
VUE D'ENSEMBLE DE VARIANTS VOIR L16

