

This catalog covers:
TH026D-□F30

This fig. covers:
TITLE

PARTS CATALOG

2-STROKE ENGINE

TH026D

PRODUCT CODE	NOTE
TH026D-CF30	BRUSH-CUTTER

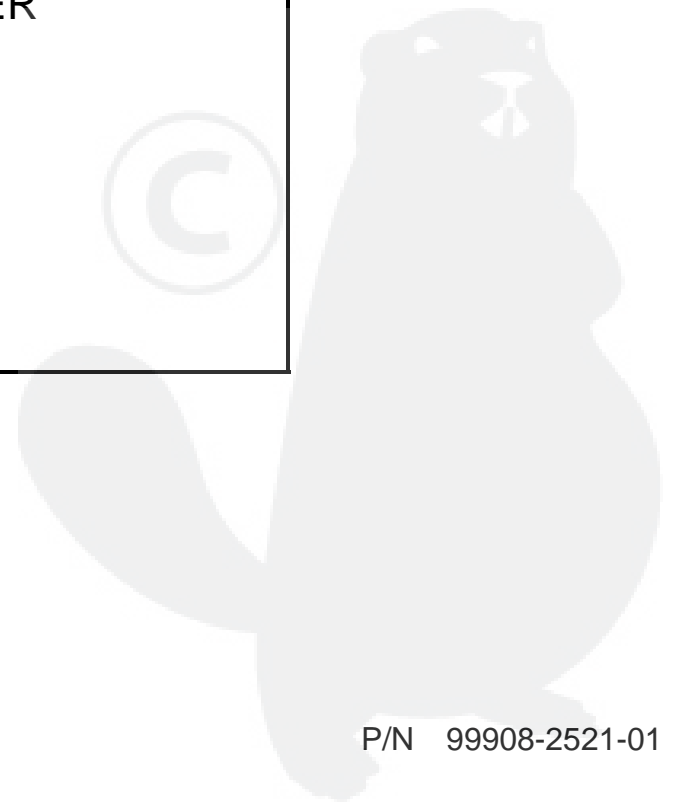

This catalog covers:
TH026D-□F30

PARTS CATALOG INTRODUCTION

This parts catalog lists parts and sub-assemblies provided as service parts. When it becomes necessary to replace parts, always use KAWASAKI GENUINE PARTS which have passed strict inspection which guarantees quality and performance.

1. HOW TO ORDER PARTS

- When ordering the parts, be sure to use the parts catalog corresponding to the product code. Check the product revision codes on the product and the catalog.
 Product Code (example) : FA130D-AA00
 Product Revision Code
- Specify the part code (all digits) exactly as listed in this catalog on your parts order.
- The parts not shown in the illustrations of this catalog are not sold separately; only the complete units or next higher assemblies illustrated are supplied as the service parts.

2. EXPLANATION OF PARTS CATALOG FORMAT

This catalog covers: **TH026D-□A10**

This fig. covers: **01 CYLINDER/CRANKCASE**

Ref. No.	Part No.	Description	Quantity
11005	11005-2137	CYLINDER-ENGINE	1
11060	11060-2402	GASKET,CYLINDER	1
11065	11065-2064	CAP	2
14002	14002-2327	CRANKCASE	1
14002A	14002-2328	CRANKCASE	1
34001	34001-2083	STAND	1
92009	92009-2115	SCREW	3
92043	92043-1502	PIN	2
92045	92045-2006	BEARING-BALL,6000C3	2
92049	92049-2074	SEAL-OIL	2
92150	92150-2091	BOLT	4

1 JUN.03.1999 E0110-A216A

1) Product Code

This code describes the product code covered by this catalog. The product revision code, which is a part of the product code, is omitted.

2) Part Group Title

This title is the representative name for the group of parts illustrated on the page.

3) Reference Number

The reference numbers are shown on the illustration and the list as the link between them.

This fig. covers:
PARTS LIST INFORMATION

4) Part Number

This is the key of your parts ordering. Three kinds of part number are used in this catalog.

- Structure 1
- Structure 2
- Standard Hardware Number (for bolts, nuts, washer, or the like)

5) Description and Additional Information

The part name, the location, the size, and the serial number as additional information, etc. are described here. Use them to find out and check the part required.

When a part number is changed without change of the product revision code and the changed parts are not interchangeable, the serial number of the product is noted as follows;

- (- FA130 - 100001) : Affected units are from beginning of the product of the product code up to and including this serial number.
- (FA130 - 100002 -) : Affected units are from this serial number and above.
- (FA130 - 100002 - FA130 - 110001) : Affected units are in this serial number range.

6) Quantity

The figure shows quantity of the part required at the indicated position on the illustration and for the specified product revision code.

The asterisk (*) on this column means the part can be used as the substitute on the product and is supplied until the stock is exhausted.

Note:Some small parts will be supplied by units.

Example: If six (6) bolts are ordered and the minimum quantity per unit is five (5), two (2), units of the bolt will be delivered.

7) Product Revision Code

This Code indicates an important change which affects the service parts interchangeability.

3. ABBREVIATIONS

#.....Number	FR.....Front	RH.....Right Hand
&.....And	G.....Gram	RPM.....Revolutions Per Minute
(+).....Plus	HEX.....Hexagonal	RR.....Rear
(-).....Minus	ID=.....Inside Diameter	STD.....Standard
2ND.....Second	IN.....Inch	T.....Teeth
3RD.....Third	L=.....Length	T=.....Thickness
4TH.....Fourth	LH.....Left Hand	U/S.....Under Size
A.....Ampere	LWR.....Lower	UPP.....Upper
AR.....As Required	MM.....Millimeter	V.....Volt
ASSY.....Assembly	O/S.....Over Size	W.....Watt
CNT.....Center	OD=.....Outside Diameter	
COMP.....Complete	REF.....Reference	

This catalog covers:
TH026D- □ F30

This fig. covers:
01 CYLINDER/CRANKCASE

E0110-A364A

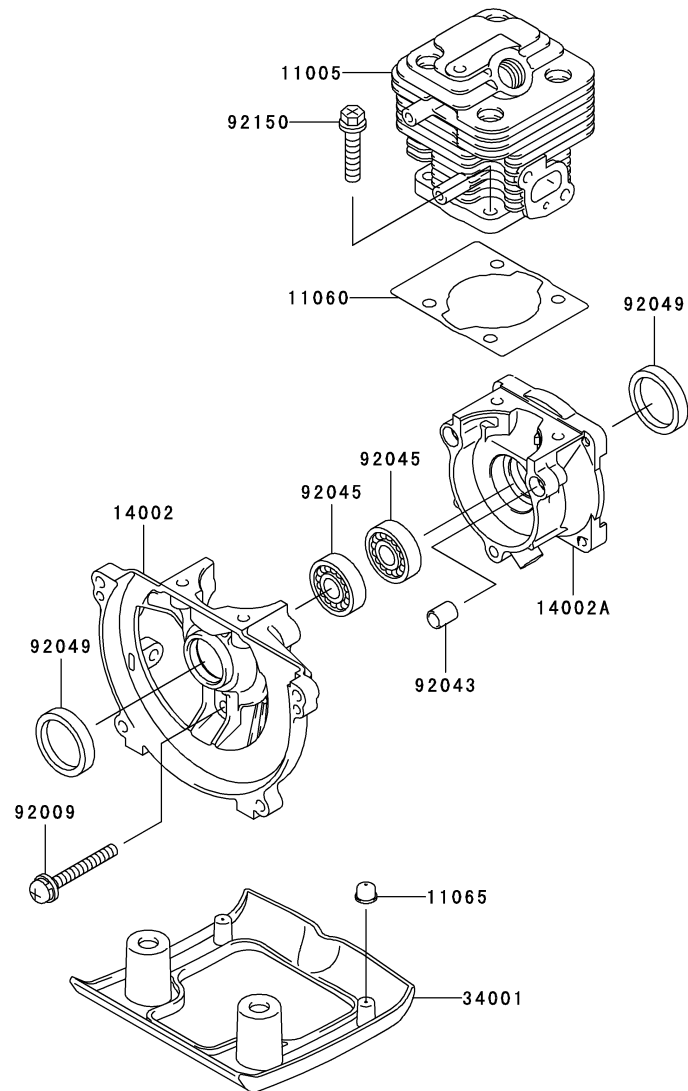

Ref. No.	Part No.	Description	Quantity
11005	11005-2137	CYLINDER-ENGINE	1
11060	11060-2402	GASKET,CYLINDER	1
11065	11065-2064	CAP	2
14002	14002-2340	CRANKCASE	1
14002A	14002-2345	CRANKCASE	1
34001	34001-2083	STAND	1
92009	92009-2115	SCREW	3
92043	92043-1302	PIN	2
92045	92045-2006	BEARING-BALL,6000C3	2
92049	92049-2074	SEAL-OIL	2
92150	92150-2091	BOLT	4



This catalog covers:
TH026D- □ F30

This fig. covers:
02 PISTON/CRANKSHAFT

E0120-A133A

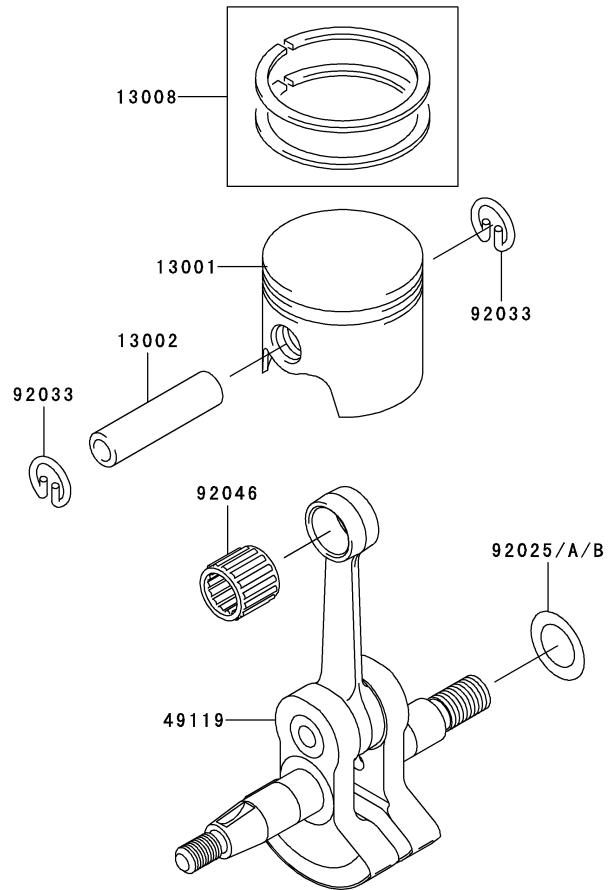

Ref. No.	Part No.	Description	C	Quantity
13001	13001-2146	PISTON-ENGINE		1
13002	13002-2058	PIN-PISTON		1
13008	13008-6046	RING-SET-PISTON		1
49119	49119-2188	CRANKSHAFT-ASSY		1
92025	92025-2125	SHIM,T=0.20	AR	
92025A	92025-2126	SHIM,T=0.40	AR	
92025B	92025-2127	SHIM,T=0.60	AR	
92033	92033-2191	RING-SNAP		2
92046	13033-2003	BEARING-NEEDLE		1



This catalog covers:
TH026D- □ F30

This fig. covers:
03 COOLING-EQUIPMENT

E0150-A275A

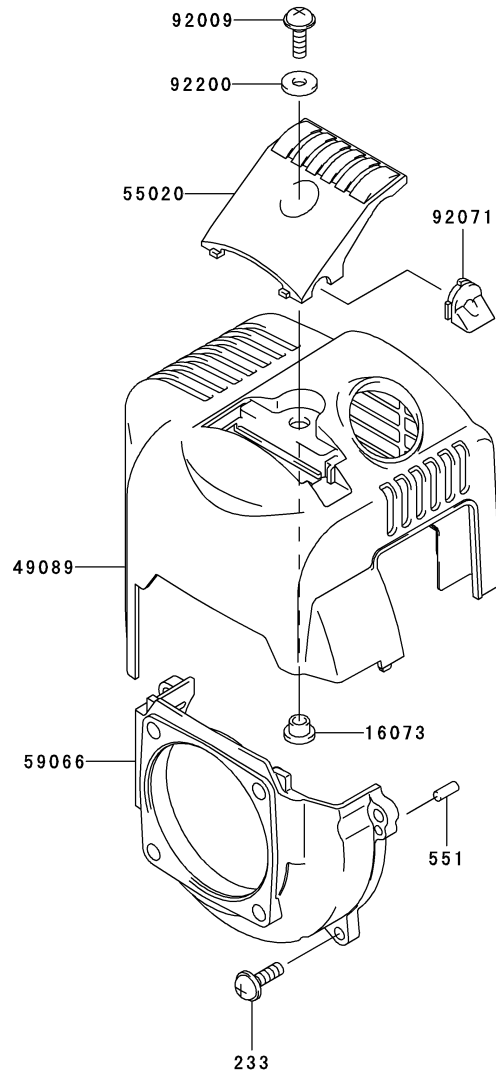

Ref. No.	Part No.	Description	Quantity
16073	16073-2197	INSULATOR	1
49089	49089-2592	SHROUD-ENGINE	1
55020	55020-2125	GUARD	1
59066	59066-2751-9B	HOUSING-FAN	1
92009	92009-2394	SCREW,5X16	1
92071	92071-2156	GROMMET	1
92200	92200-2156	WASHER	1
233	233B0516	SCREW-PAN-WP+-	4
551	551A0410	PIN-DOWEL	2



This catalog covers:
TH026D- □ F30

This fig. covers:
04 ELECTRIC-EQUIPMENT

E0160-A519B

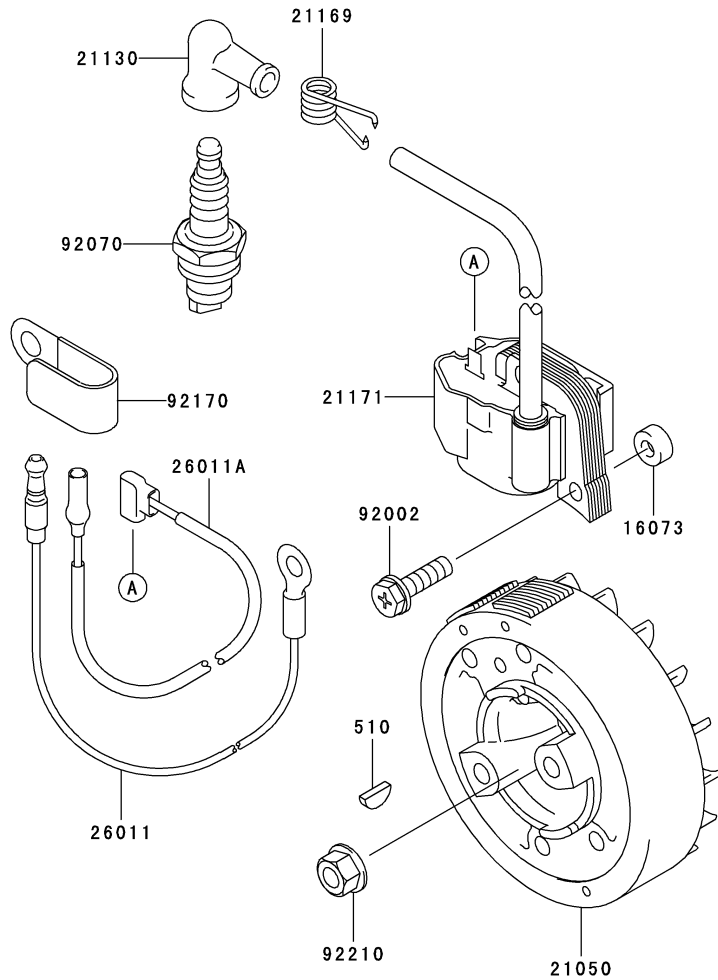

Ref. No.	Part No.	Description	Quantity
16073	16073-2198	INSULATOR	2
21050	21050-2303	FLYWHEEL	1
21130	21130-2056	CAP-SPARK PLUG	1
21169	21169-2051	TERMINAL	1
21171	21171-2233	COIL-ASSY-IGNITION	1
26011	26011-2113	WIRE-LEAD	1
26011A	26011-2376	WIRE-LEAD,L=230	1
92002	92002-2197	BOLT,4X20	2
92070	92070-2108	PLUG-SPARK,BPMR6A(NGK),SOLID	1
92170	92170-2041	CLAMP	1
92210	92210-2062	NUT	1
510	510A3100	KEY-WOODRUFF	1

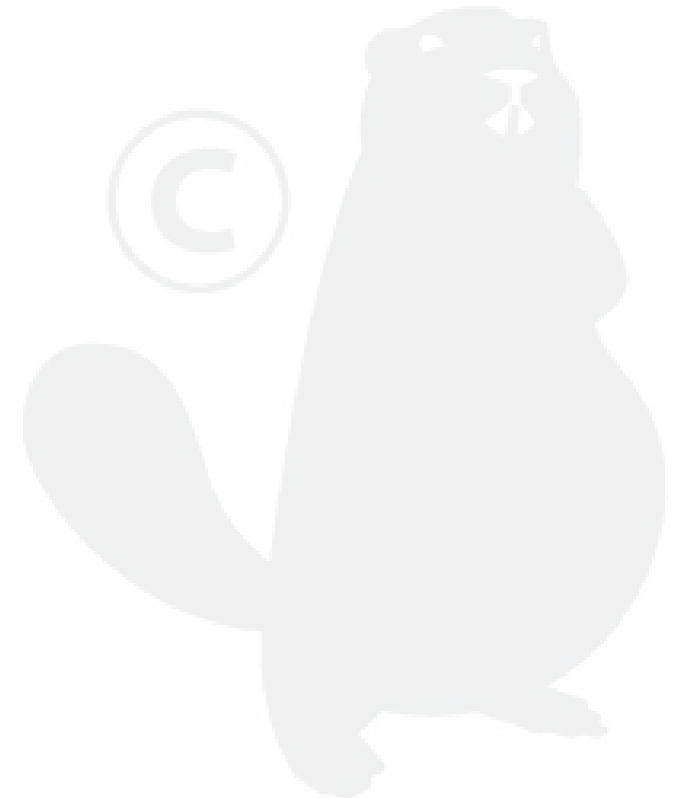

This catalog covers:
TH026D- □ F30

05

This fig. covers:
CONTROL-EQUIPMENT

E0170-A237A

Ref. No.	Part No.	Description	C	Quantity
32099	32099-2326	CASE		1
54012	54012-2525	CABLE-THROTTLE		1

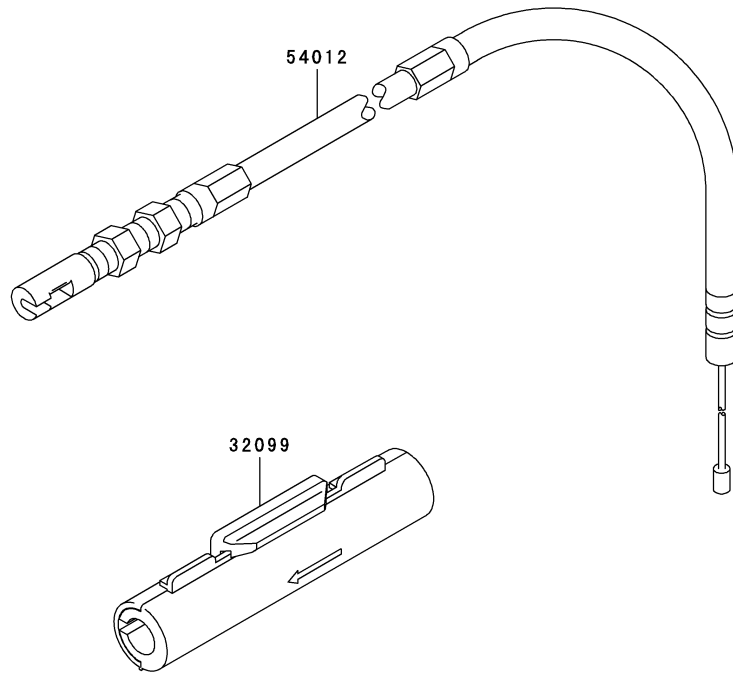

This catalog covers:
TH026D- □ F30

This fig. covers:
06 CARBURETOR

E0180-A622A

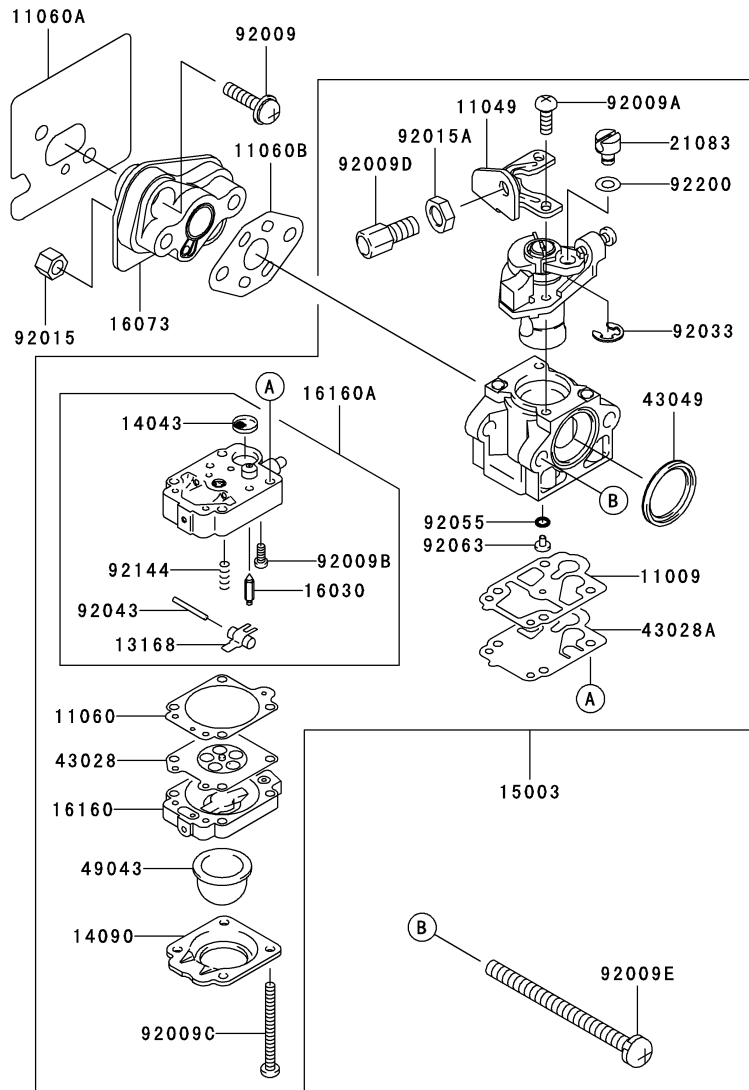

Ref. No.	Part No.	Description	Quantity
11009	11009-2757	GASKET	1
11049	11049-2006	BRACKET	1
11060	11060-2111	GASKET	1
11060A	11060-2403	GASKET,INSULATOR	1
11060B	11060-2404	GASKET,CARBURETOR	1
13168	16055-2051	LEVER	1
14043	14043-2051	FILTER	1
14090	14090-2017	COVER,PRIMER PUMP	1
15003	15003-2664	CARBURETOR-ASSY	1
16030	16030-2078	VALVE-FLOAT	1
16073	16073-2231	INSULATOR	1
16160	16160-2089	BODY	1
16160A	16160-2103	BODY	1
21083	21083-2073	ARM	1
43028	43028-2054	DIAPHRAGM	1
43028A	43028-2067	DIAPHRAGM	1
43049	43049-2060	PACKING	1
49043	49043-2067	PUMP-PRIMING	1
92009	92009-2249	SCREW,5X20	2
92009A	92009-2277	SCREW	2
92009B	92009-2336	SCREW	1
92009C	92009-2337	SCREW	4
92009D	92009-2354	SCREW	1
92009E	92009-2398	SCREW,5X60	2
92015	92015-2097	NUT,M5	2
92015A	92015-2145	NUT	1
92033	92033-2078	RING-SNAP	1
92043	92043-2094	PIN	1
92055	92055-2147	RING-O	1
92063	92063-2356	JET-MAIN,#37.5	1
92144	92144-2308	SPRING	1
92200	92200-2074	WASHER	1

This catalog covers:
TH026D- □ F30

07

This fig. covers:
AIR-FILTER/MUFFLER

E0190-A508C

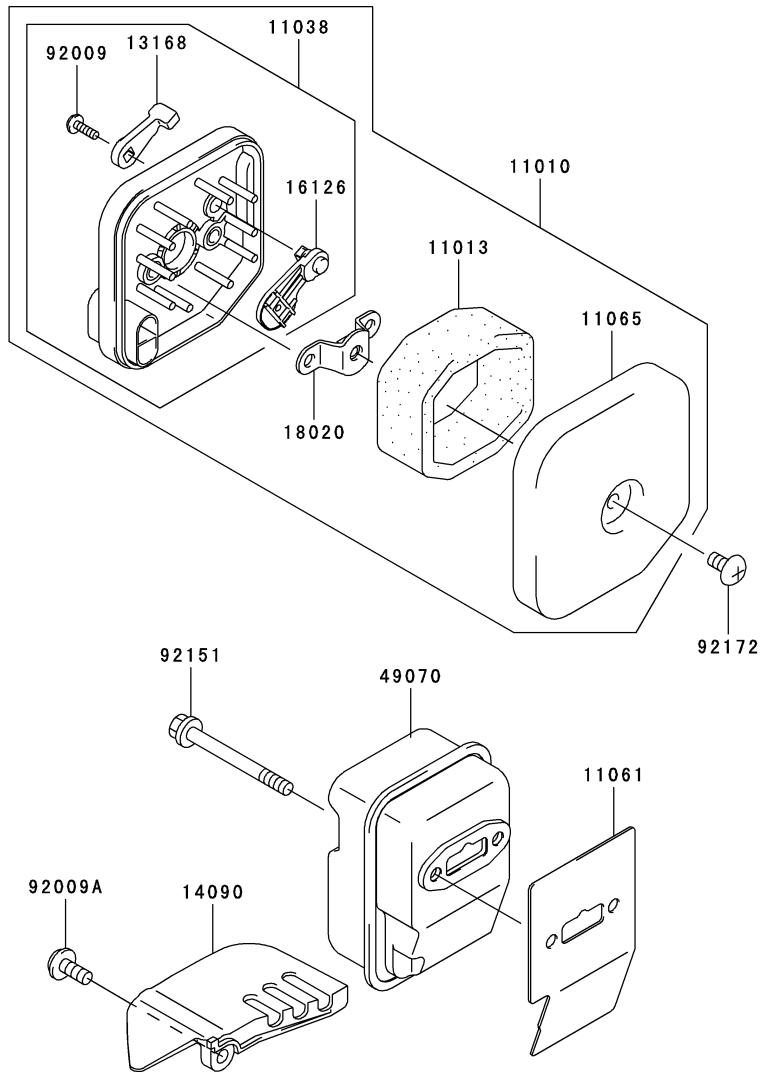

Ref. No.	Part No.	Description	Quantity
11010	11010-2530	FILTER-ASSY-AIR	1
11013	11013-2182	ELEMENT-AIR FILTER	1
11038	11038-2067	CASE-ASSY-AIR FILTER	1
11061	11061-2076	GASKET	1
11065	11065-2053	CAP,AIR FILTER	1
13168	13168-2422	LEVER	1
14090	14090-2118	COVER	1
16126	16126-2216	VALVE	1
18020	18020-2082	BAFFLE	1
49070	49070-2722	MUFFLER-COMP	1
92009	92009-2359	SCREW,3X10	1
92009A	92009-2393	SCREW,5X12	1
92151	92151-2074	BOLT,5X55	2
92172	92172-0007	SCREW,5X10	1



This catalog covers:
TH026D- □ F30

This fig. covers:
08 FUEL-TANK/FUEL-VALVE

E0200-A372A

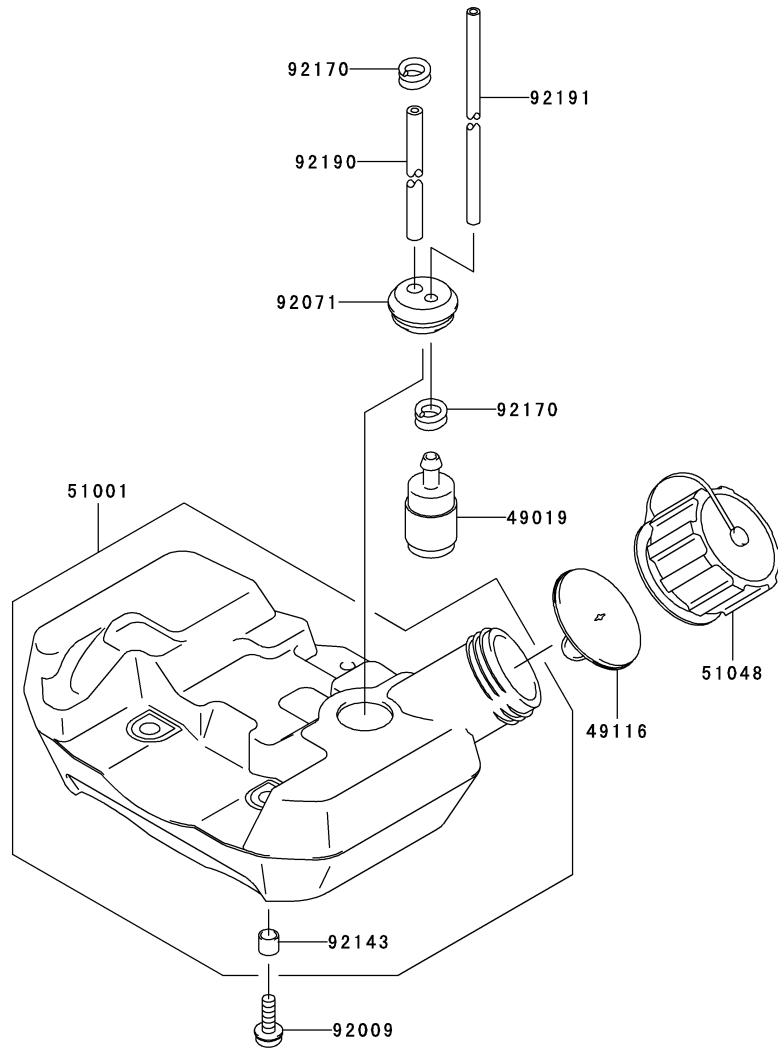

Ref. No.	Part No.	Description	Quantity
49019	49019-2111	FILTER-FUEL	1
49116	49116-2064	VALVE-ASSY	1
51001	51001-2315	TANK-COMP-FUEL	1
51048	51048-2078	CAP-ASSY-TANK	1
92009	92009-2368	SCREW,5X16	3
92071	92071-2142	GROMMET,FUEL TANK	1
92143	92143-2161	COLLAR,TANK	2
92170	92170-2080	CLAMP,FUEL FILTER	2
92190	92190-2174	TUBE,3X6X90	1
92191	92191-2102	TUBE,3X5X182	1



This catalog covers:
TH026D- □ F30

09 STARTER

This fig. covers:

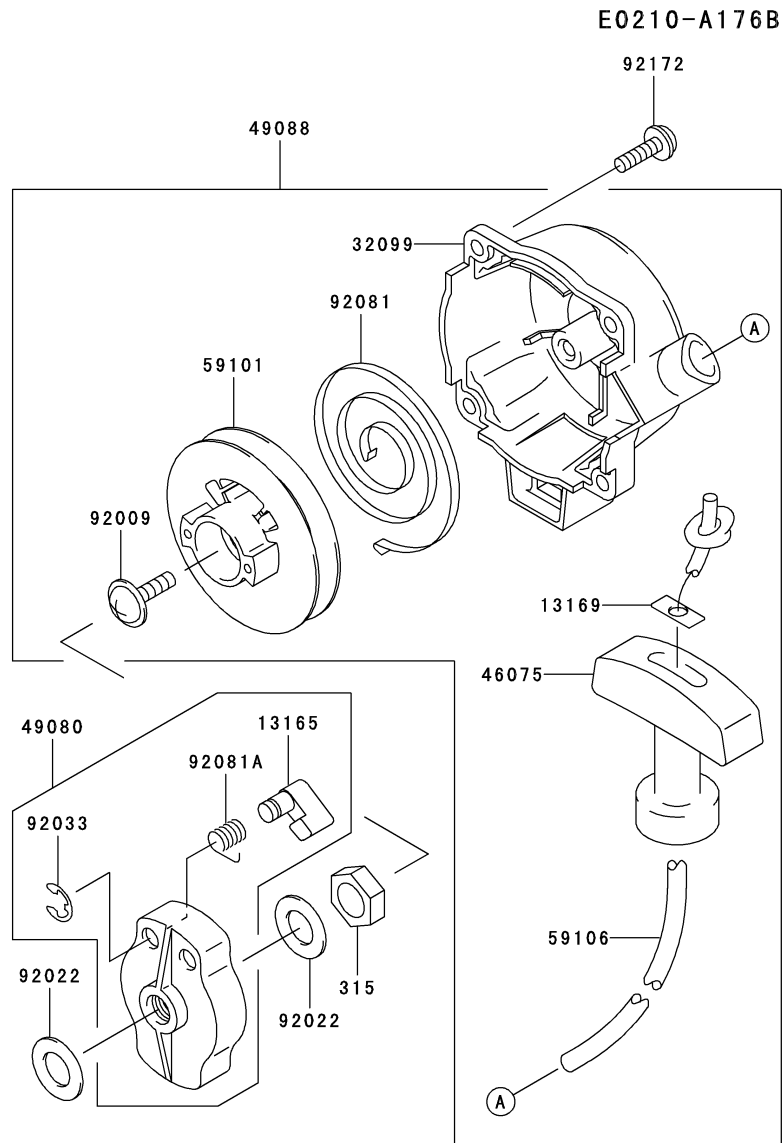

Ref. No.	Part No.	Description	Quantity
		C	
13165	13165-2052	PAWL	1
13169	13169-2386	PLATE,RECOIL STARTER	1
32099	32099-2393	CASE,RECOIL STARTER	1
46075	46075-2116	GRIP,RECOIL STARTER	1
49080	49080-2182	PULLEY-STARTING	1
49088	49088-2532	STARTER-RECOIL	1
59101	59101-2106	REEL,RECOIL STARTER	1
59106	59106-2147	ROPE,3.5X800	1
92009	92009-2358	SCREW	1
92022	92022-2138	WASHER,8X16X1.2	2
92033	92033-2010	RING-SNAP	1
92081	92081-2238	SPRING,RECOIL	1
92081A	92081-2253	SPRING	1
92172	92172-2061	SCREW,4X14	4
315	315B0800	NUT-HEX-FINE	1

This catalog covers:
TH026D- □ F30

10

This fig. covers:
P.T.O-EQUIPMENT

E0220-A027A

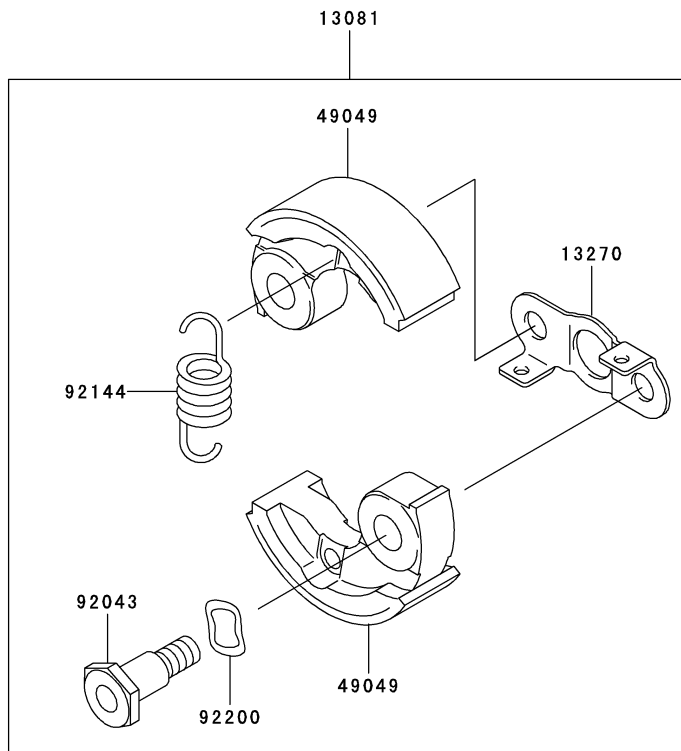

Ref. No.	Part No.	Description	Quantity
13081	13081-2225	CLUTCH-ASSY	1
13270	13270-2048	PLATE	1
49049	49049-2096	SHOE-CLUTCH	2
92043	92043-2182	PIN	2
92144	92144-2086	SPRING,CLUTCH	1
92200	92200-2065	WASHER	2

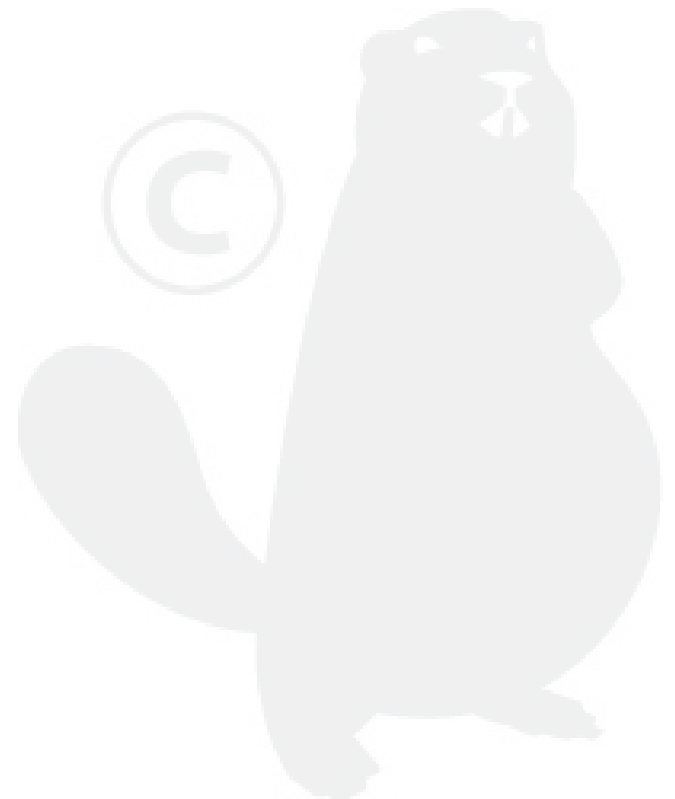

This catalog covers:
TH026D- □ F30

11

This fig. covers:
LABEL

F0290-A611A

Ref. No.	Part No.	Description	Quantity
56031	56031-2468	LABEL-MANUAL	1
56039	56039-2877	LABEL-PRODUCT	1
56070	56070-2020	LABEL-WARNING	1
56080	56080-2088	LABEL-BRAND	1

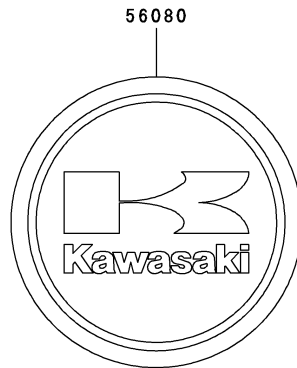
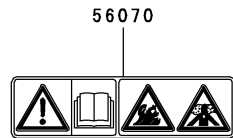
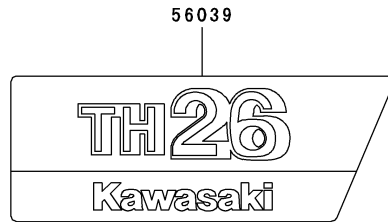
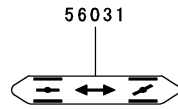

This catalog covers:
TH026D- □ F30

12

This fig. covers:
TOOL

F0300-A001A

Ref. No.	Part No.	Description	Quantity
56007	56007-2051	TOOLKIT	1
92107	92107-2057	TOOL-DRIVER	1
92110	92110-2051	TOOL-WRENCH,19X21	1

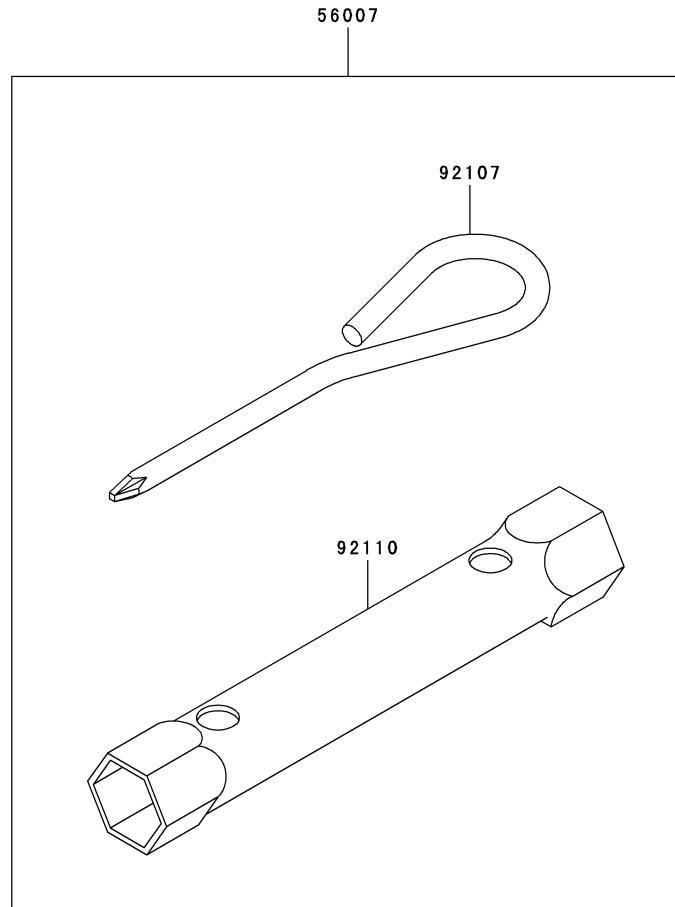

This catalog covers:

TH026D- □ F30

This fig. covers:

PART NAME INDEX

AIR-FILTER/MUFFLER.....	07
CARBURETOR.....	06
CONTROL-EQUIPMENT.....	05
COOLING-EQUIPMENT.....	03
CYLINDER/CRANKCASE.....	01
ELECTRIC-EQUIPMENT.....	04
FUEL-TANK/FUEL-VALVE.....	08
LABEL.....	11
P.T.O-EQUIPMENT.....	10
PISTON/CRANKSHAFT.....	02
STARTER.....	09
TOOL.....	12

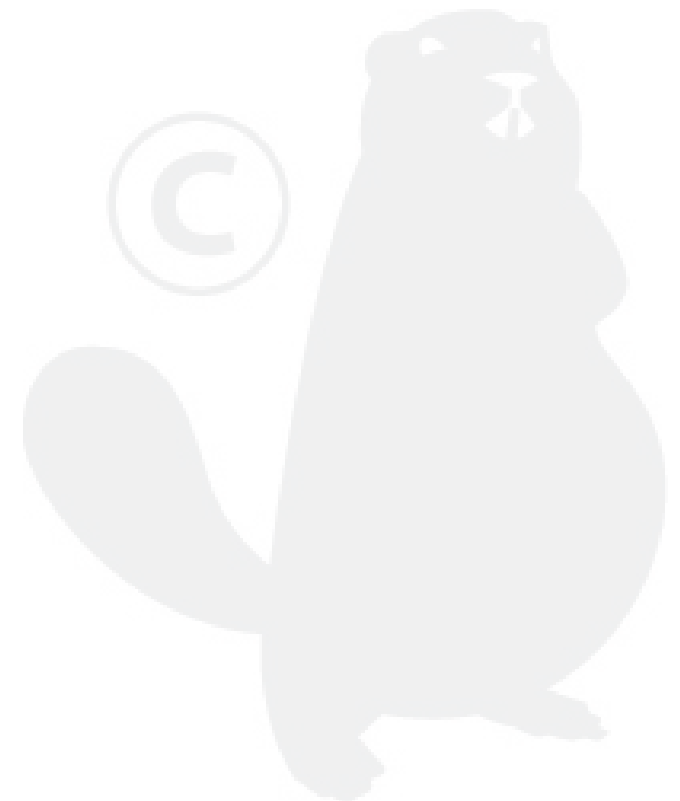

This catalog covers:

TH026D- F30

This fig. covers:

NUMERICAL PARTS INDEX

Part No.	Fig No.	Part No.	Fig No.	Part No.	Fig No.	Part No.	Fig No.	Part No.	Fig No.
11005-2137	01	49116-2064	08	92172-2061	09				
11009-2757	06	49119-2188	02	92190-2174	08				
11010-2530	07	51001-2315	08	92191-2102	08				
11013-2182	07	51048-2078	08	92200-2065	10				
11038-2067	07	510A3100	04	92200-2074	06				
11049-2006	06	54012-2525	05	92200-2156	03				
11060-2111	06	55020-2125	03	92210-2062	04				
11060-2402	01	551A0410	03						
11060-2403	06	56007-2051	12						
11060-2404	06	56031-2468	11						
11061-2076	07	56039-2877	11						
11065-2053	07	56070-2020	11						
11065-2064	01	56080-2088	11						
13001-2146	02	59066-2751-9B	03						
13002-2058	02	59101-2106	09						
13008-6046	02	59106-2147	09						
13033-2003	02	92002-2197	04						
13081-2225	10	92009-2115	01						
13165-2052	09	92009-2249	06						
13168-2422	07	92009-2277	06						
13169-2386	09	92009-2336	06						
13270-2048	10	92009-2337	06						
14002-2340	01	92009-2354	06						
14002-2345	01	92009-2358	09						
14043-2051	06	92009-2359	07						
14090-2017	06	92009-2368	08						
14090-2118	07	92009-2393	07						
15003-2664	06	92009-2394	03						
16030-2078	06	92009-2398	06						
16055-2051	06	92015-2097	06						
16073-2197	03	92015-2145	06						
16073-2198	04	92022-2138	09						
16073-2231	06	92025-2125	02						
16126-2216	07	92025-2126	02						
16160-2089	06	92025-2127	02						
16160-2103	06	92033-2010	09						
18020-2082	07	92033-2078	06						
21050-2303	04	92033-2191	02						
21083-2073	06	92043-1302	01						
21130-2056	04	92043-2094	06						
21169-2051	04	92043-2182	10						
21171-2233	04	92045-2006	01						
233B0516	03	92049-2074	01						
26011-2113	04	92055-2147	06						
26011-2376	04	92063-2356	06						
315B0800	09	92070-2108	04						
32099-2326	05	92071-2142	08						
32099-2393	09	92071-2156	03						
34001-2083	01	92081-2238	09						
43028-2054	06	92081-2253	09						
43028-2067	06	92107-2057	12						
43049-2060	06	92110-2051	12						
46075-2116	09	92143-2161	08						
49019-2111	08	92144-2086	10						
49043-2067	06	92144-2308	06						
49049-2096	10	92150-2091	01						
49070-2722	07	92151-2074	07						
49080-2182	09	92170-2041	04						
49088-2532	09	92170-2080	08						
49089-2592	03	92172-0007	07						

