

**TAVOLA RICAMBI**  
**TABLEAU PIECES DETACHEES**  
**SPARE PARTS TABLE**  
**ERSATZTEILTAFEL**  
**TABLA DE REPUESTOS**  
**TÁBUA PEÇAS DE TROCA**

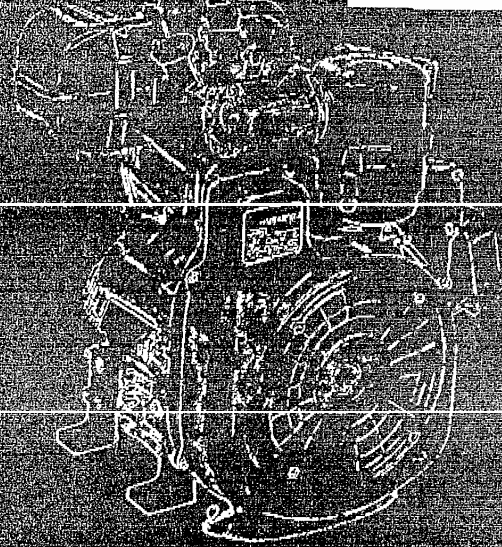

**12LD 435-2**  
**12LD 475-2**

**LOMBARDINI**  
**MOTORI**  
 RICAMBI ORIGINALI

**LOMBARDINI**  
**MOTORI**  
 PIÈCES D'ORIGINE

**LOMBARDINI**  
**MOTORI**  
 GENUINE SPARE PARTS

**LOMBARDINI**  
**MOTORI**  
 ORIGINAL ERSATZTEILE

**LOMBARDINI**  
**MOTORI**  
 REPUESTOS ORIGINALES

**LOMBARDINI**  
**MOTORI**  
 PEÇAS DE TROCA ORIGINAIS

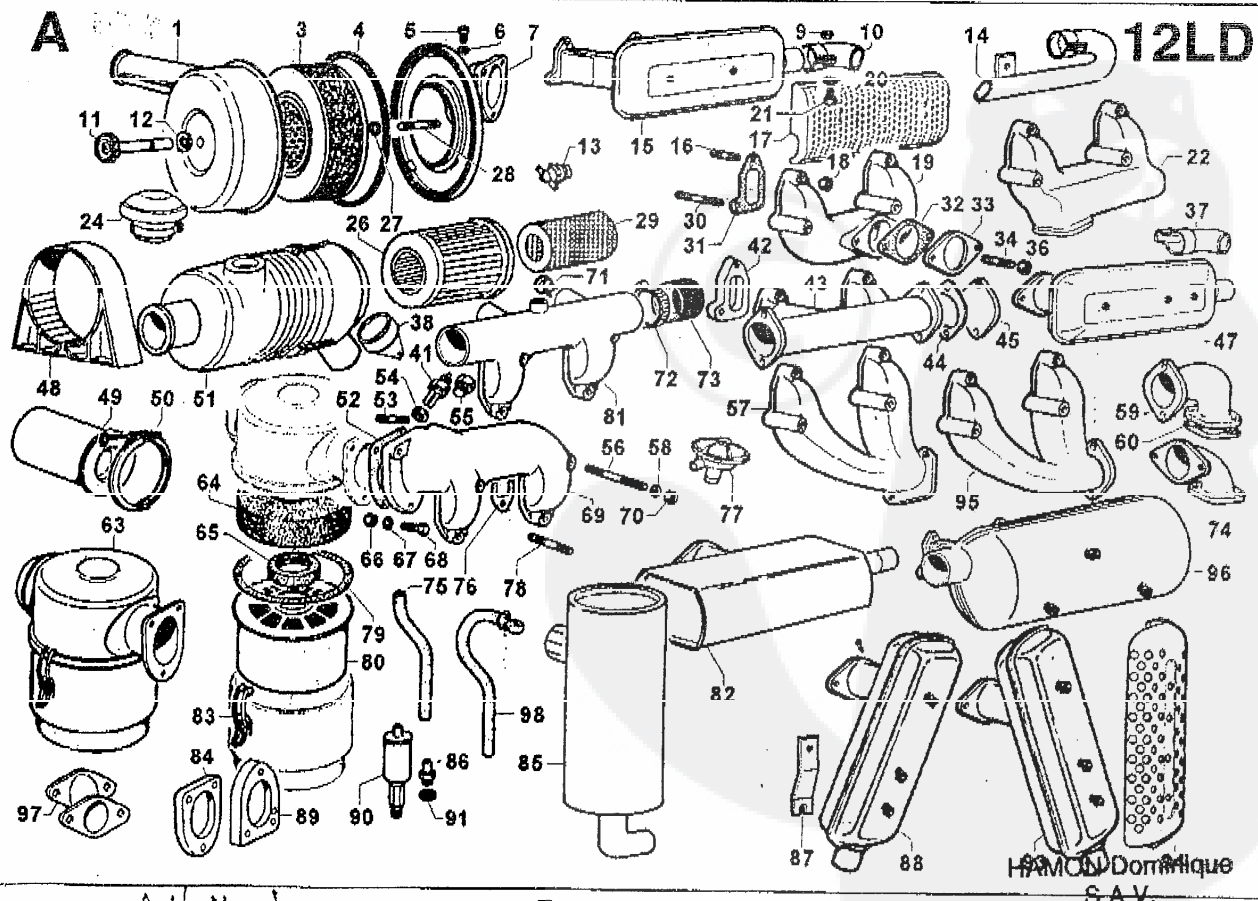

D

12LD

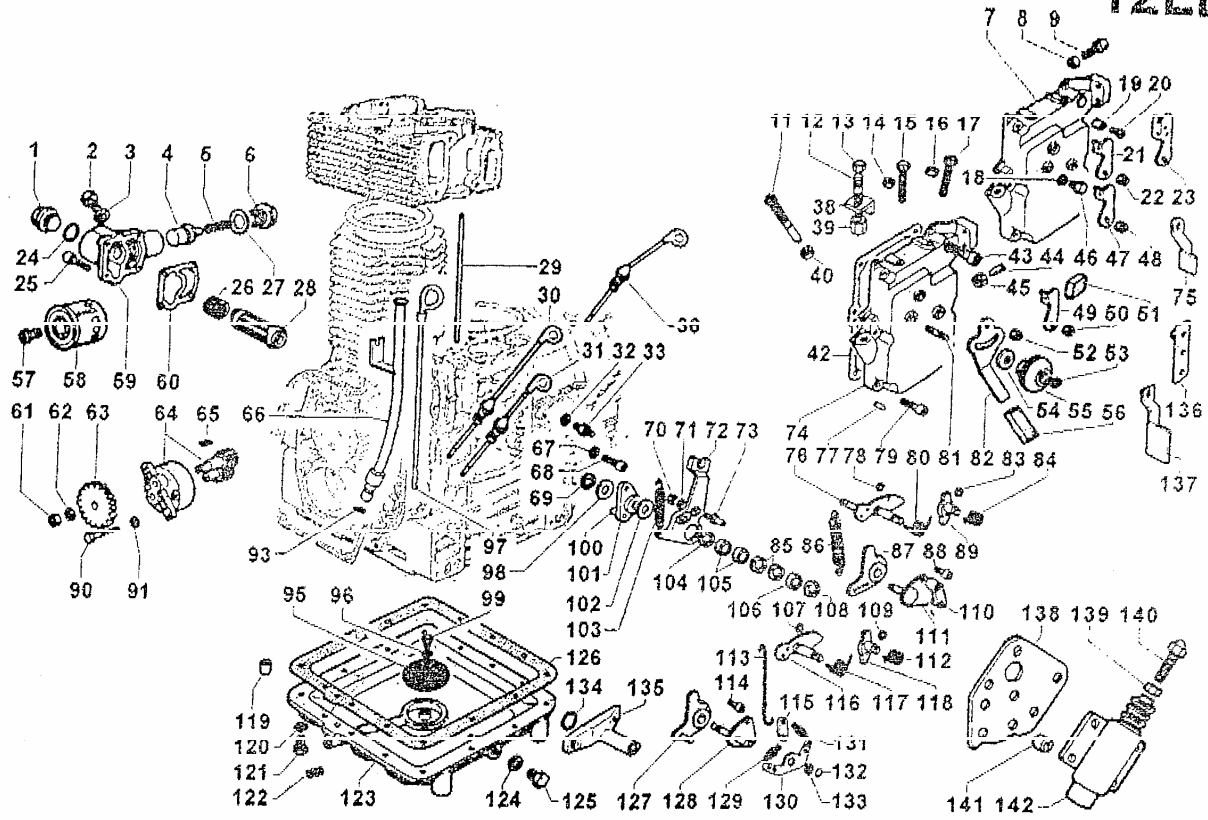

E

12LD

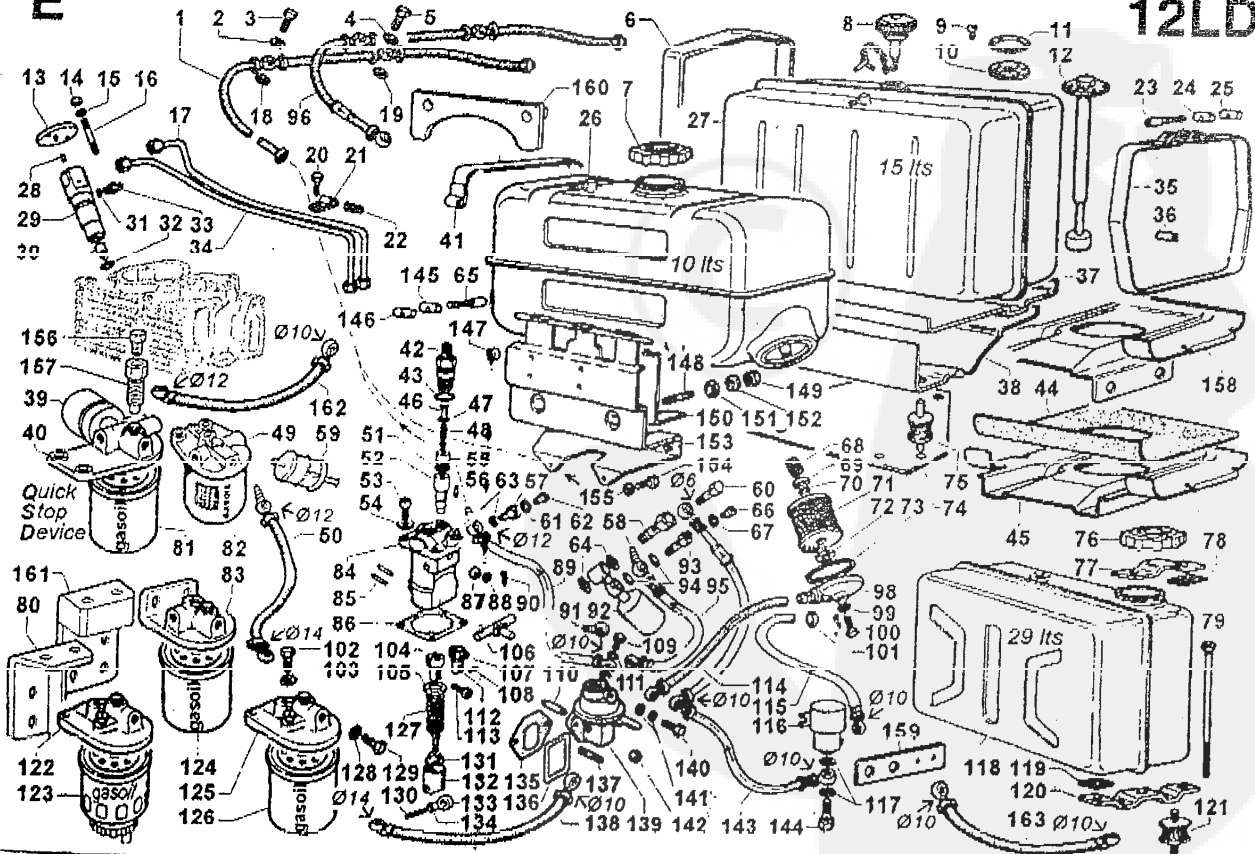

B

12LD

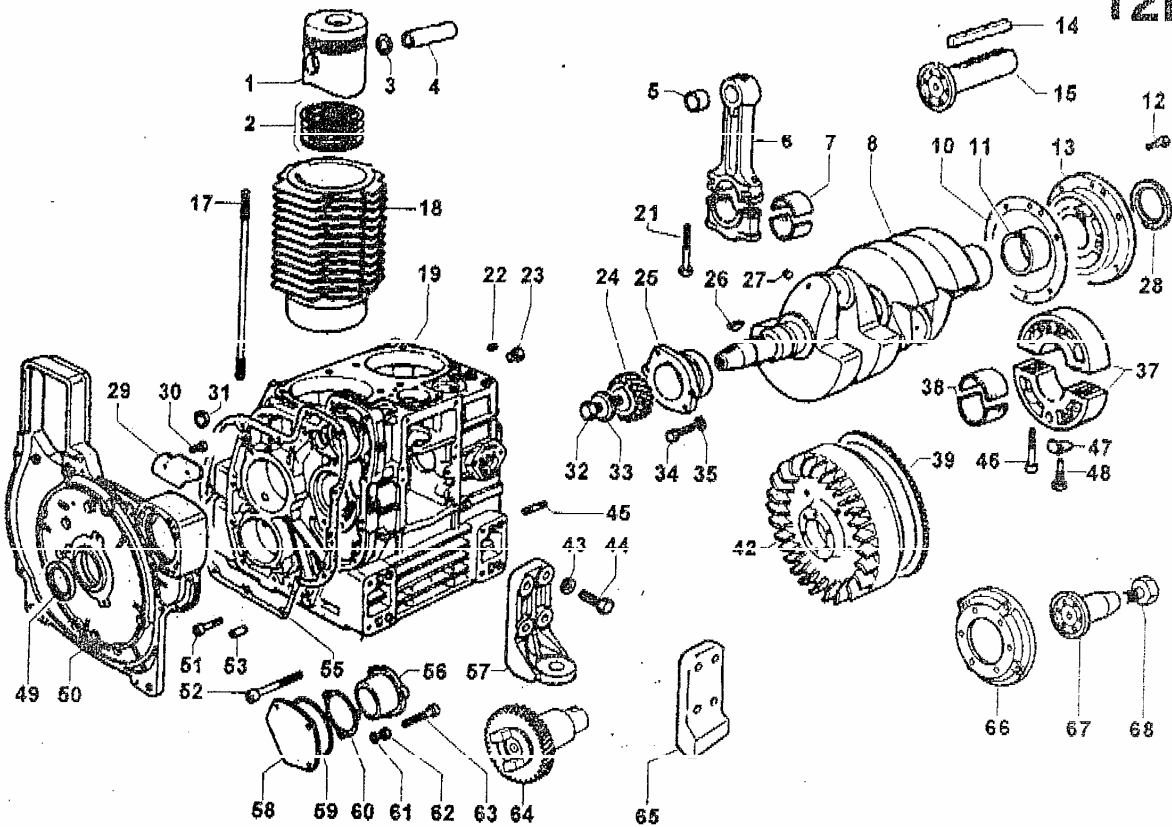

C

12LD

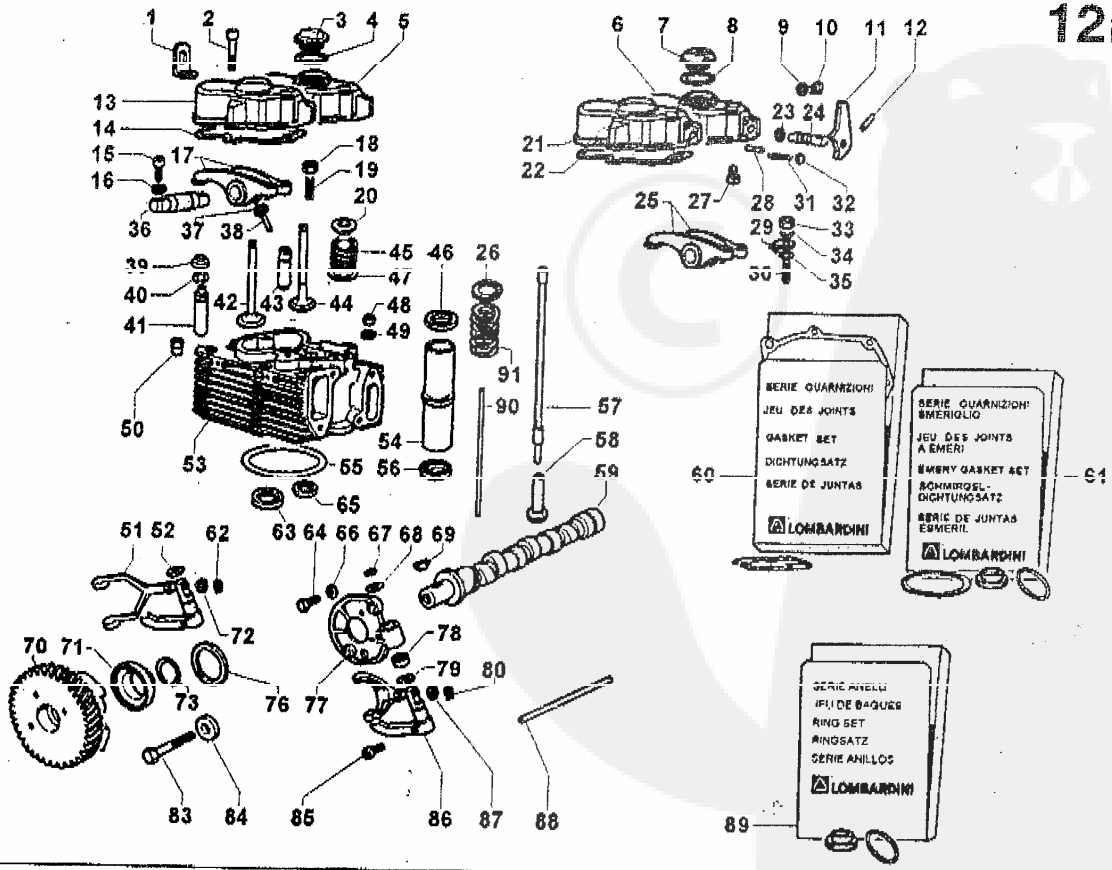

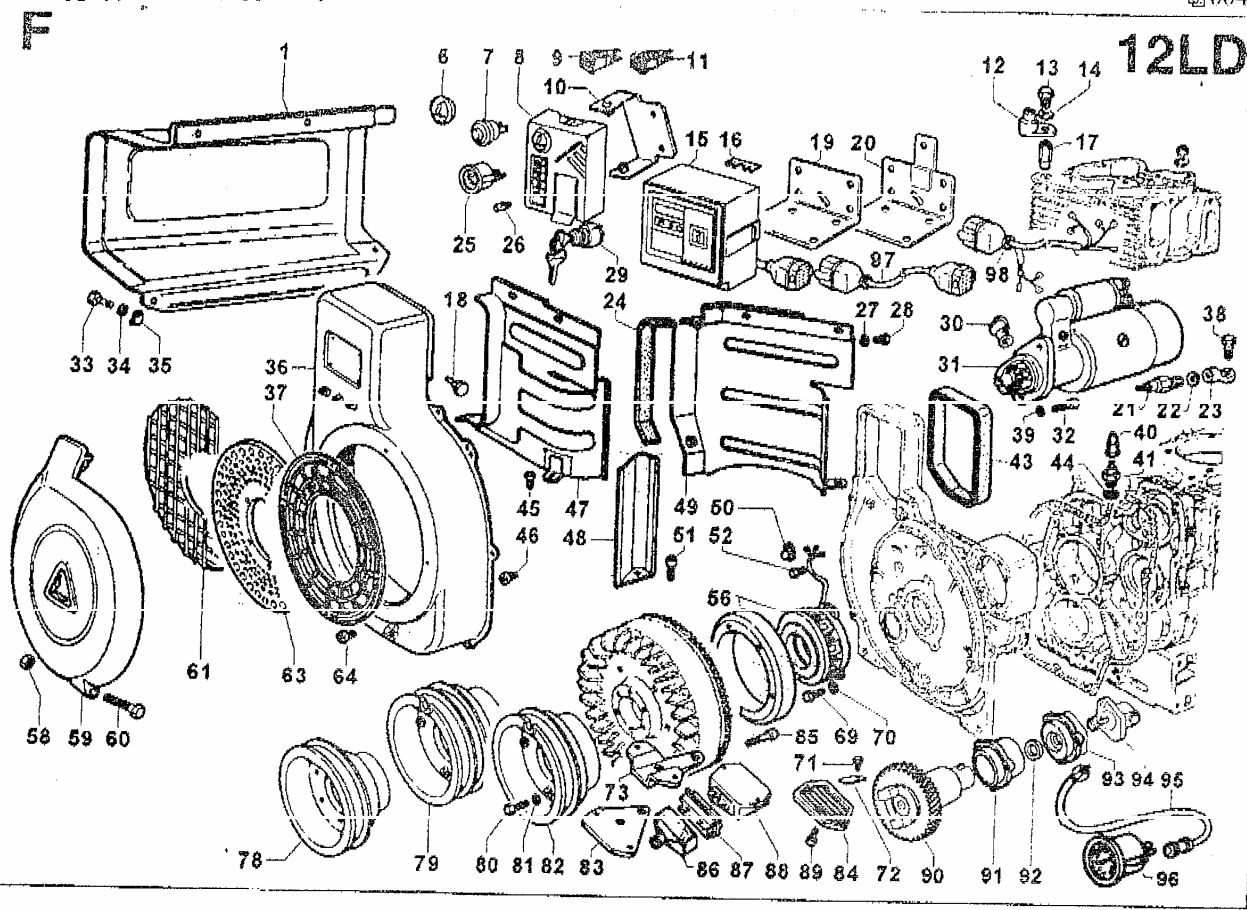

**SERVICE**

Per assistenza e ricambi rivolgersi a stazioni di servizio autorizzate Lombardini. N. Tel. su libretto service e su pagine gialle.  
 Pour toute exigence de service après vente et pièces détachées s'adresser aux Stations de service du réseau Lombardini. N. de téléphone  
 Indiqué sur brochure relative au service après vente et annuaire téléphonique.  
 For spare parts and after sale assistance contact authorized Lombardini service centers. Tel. No appears on service booklet and telephone  
 directory.  
 Für Service und Ersatzteile bitten wir sich an autorisierte Werkstätte zu wenden. Telefon-Nummer laut unserem Service-Büchlein und  
 Fernsprechbuch.  
 Para asistencia y repuestos dirigirse a las estaciones de servicio autorizadas Lombardini. N. Tel. su libretto service y su hojas amarillas.  
 Para assistência e recâmbios dirigir-se às estações de serviço autorizadas Lombardini. Número telefone e sobre a caderneta de serviço,  
 e sobre as páginas amarelas.

RICAMBI  
 COMMANDES PIÉCES  
 PART ORDERS  
 TEILBESTELLUNGEN  
 EDIDOS DE REPUESTOS  
 EDIDOS RECÂMBIOS

TIPO MOTORE - MATRICOLA  
 TYPE DE MOTEUR - MATRICULE  
 ENGINE TYPE - SERIAL NUMBER  
 MOTORTYP  
 MOTORENUMMER  
 TIPO DEL MOTOR  
 NUMERO DEL MOTOR  
 TIPO DE MOTOR  
 NUMERO DO MOTOR

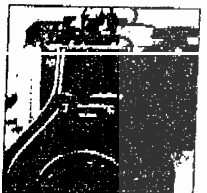

MATRICOLA DEL RICAMBIO  
 REFERENCE DE LA PIÉCE  
 SPARE PART NUMBER  
 BESTELNUMMER DES TEILES  
 REFERENCIA DEL REPUESTO  
 REFERÉNCIA DO RECÂMBIO

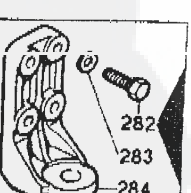
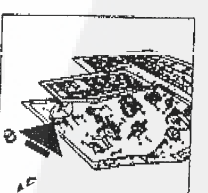

Disegni non impegnativi - Per applicazioni speciali consultare i Centri Assistenza e Ricambi.  
 Des illustrations peuvent être modifiées - Pour les adaptations consulter les Agents Service.  
 Drawings are subject to modifications - Please contact Service Centers for special applications.  
 Änderungen vorbehalten - Für Sonderanfertigungen sich an Service Werkstätten wenden.  
 Ilustraciones pueden ser modificadas - Para aplicaciones especiales contactar a los Centros Repuestos.  
 Desenhos podem ser alterados - Para aplicações especiais consultar os Centros de Assistência e Peças.

**LOMBARDINI**

ABBRICCA ITALIANA MOTORI S.p.A.  
 2100 REGGIO EMILIA (ITALIA) CAS. POST. 1074 0116  
 Tel. (0522) 38911 Teleg. LOMBARMOTR Tel. 4530003 MOTLOM I

LOMBARDINI USA INC. 2120 Boone Road, Bldg. 300, Suite 300 - Duluth, GA 30134, U.S.A.  
 LOMBARDINI MOTOREN GMBH - Postfach 64 - 60437 Frankfurt/Main - Deutschland  
 LOMBARDINI (UK) LTD. Unit 57 Ferry Mills, Coney Mead - Oxford OX2 0ES, U.K.  
 LOMBARDINI ESPAÑA S.A. Zona Industrial Cova Solera, s/n - 08191 RUBI - BARCELONA, España

|                       |                          |                     |                              |              |                          |
|-----------------------|--------------------------|---------------------|------------------------------|--------------|--------------------------|
| ENTE COMPILATORE RICA | COD. LIBRO<br>1.5302.508 | MODELLO N°<br>60777 | DATA EMISSIONE<br>10/04/1999 | REVISIONE 00 | DATA VISTO<br>10/04/1999 |
|-----------------------|--------------------------|---------------------|------------------------------|--------------|--------------------------|



12LD

435-2 - 475-2

vedi TAVOLA RIC./see SPARE P. TABLE/voir TABLEAU P.DETACH. 1.5302.508

\*\*\*\*\*
Aprile/April/Avril 1999
\*\*\*\*\*

MOTORI/ENGINES/MOTEURS Gr.12
Colonna/Column/Colonne 1 = 12LD 435-2
2 = 12LD 475-2

Vedi/See/Voir

Libretto Uso e Man./Use-Maint.booklet/Livret Emploi-Entret. .... 1.5302.392
Libretto Service/Service directory/Reseau S.A.V. .... 1.7968.002

- A - valido dal motore ... vedi Circolare Tecnica
B - valido fino al motore ... vedi Circolare Tecnica
I - intercambiabile ... vedi Circolare Tecnica
E - ad esaurimento/exhausting part/piece en epuisement.
npd non più disponibile/no longer available/non plus dispnible
CT vedi circolare tecnica/see service letter/voir circulaire technique

Descrizioni non impegnative/Subject to modifications/Modifications rùservùes
TECO/ATL/Assistenza Tecnica Lombardini/Aprile 1999

- Riquadro A ASPIRAZIONE/SCARICO
Riquadro B BIELLA/PISTONE/ALBERO A GOMITO/VOLANO/BASAMENTO/FLANGIATURA
Riquadro C TESTA/CAPPELLO BIL./VALVOLE/DISTRIBUZIONE/REG.GIRI
Riquadro D COMANDI/CIRCUITO LUBRIFICAZIONE
Riquadro E CIRCUITO COMBUSTIBILE
Riquadro F RAFFREDDAMENTO/AVVIAMENTO

Tipo motore
Engine type
Type moteur

12LD 435-2
(dal motore/fron eng.
s.No. 3917191)

12LD 475-2

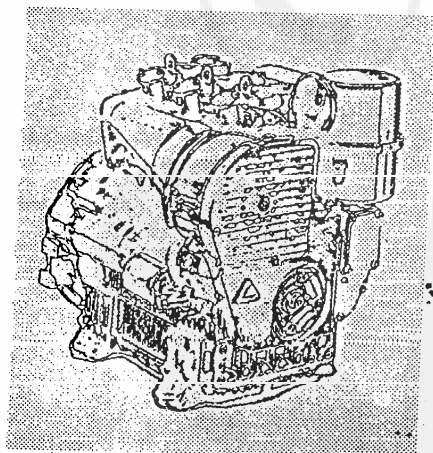

Blocco motore
Short block
Bloc moteur

1560.242 435

1560.238 475



12LD 435-2 - 12LD 475-2  
vedi Tavola Ric./see Parts Table 1.5302.508

| Pos.  | Matricola/Part No. | Note/Remarks                                                             | 12LD435-2 | 12LD475-2 |
|-------|--------------------|--------------------------------------------------------------------------|-----------|-----------|
| A 1   | =3700 133 560      | FILTRO ARIA A SECCO/DRY AIRCLEANER<br>(Pos. 1-3-4-5-7-11-12-27-28)       | 1         | 1         |
| A 1+  | 2605.034 560       | coperchio filtro aria/cover                                              | 1         | 1         |
| A 3+  | 2175.048 560       | cartuccia filtro aria/cartridge                                          | 1         | 1         |
| A 4+  | 1261.067 560       | anello tenuta/seal ring                                                  | 1         | 1         |
| A 5+  | 8965.001 9         | tappo/plug M 10                                                          | 1         | 1         |
| A 6   | 4670.059 9         | guarniz. rame/copper gasket d.10                                         | 1         | 1         |
| A 7+  | 8741.015 560       | supporto/support                                                         | 1         | 1         |
| A 8   | 3240.018 9         | dado/nut                                                                 | 1         | 1         |
| A 10  | 9170.018 2910      | terminale/muffler-end (d.36,5/38)                                        | 1         | 1         |
|       | 9170.052 5600      | terminale/muffler end (d.39,5/42)                                        | 1         | 1         |
| A 11+ | 9895.067 560       | volantino/knob                                                           | 1         | 1         |
| A 12+ | 4490.017 273       | guarnizione/gasket                                                       | 1         | 1         |
| A 13  | 8345.049 107       | segnal.intasamento/dust indicat.                                         | 1         | 1         |
| A 14  | 9170.101 435       | terminale marmitta/muffler end                                           | 1         | 1         |
| A 15  | 5460.290 3600      | marm.collett/muffler-manif 416x143<br>lungh.coll./muffler lenght mm 88   | 1         | 1         |
|       | 5460.192 560       | marm.collett/muffler-manif 395x122<br>lungh.coll./muffler lenght mm 143  | 1         | 1         |
|       | 5460.317 5600      | marm.coll/muffl (scar.lato dist.)<br>lungh.coll./muffler lenght mm 108   | 1         | 1         |
| A 16+ | 6780.084 9         | prigioniero/stud M 8 x 40 (52)                                           | 2         | 2         |
| A 17  | 6927.172 560       | protezione marm./muffler guard                                           | 1         | 1         |
| A 18  | 3240.069 9         | dado/nut                                                                 | 4         | 4         |
| A 19  | 2486.028 560       | collettore scarico                                                       | 1         | 1         |
| A 20  | 7565.007 9         | rondella/washer                                                          | 1         | 1         |
| A 21  | 1770.005 9         | bullone/bolt M 8 x 1,25 x 22                                             | 1         | 1         |
| A 22  | 2486.071 360       | collettore scar./exh.manifold                                            | 1         | 1         |
| A 24  | 2136.053 104       | cappellotto/filter cap (5''aircl.)                                       | 1         | 1         |
| A 26  | 2175.124 104       | cartucc. princ./main cartridge 5''                                       | 1         | 1         |
| A 27+ | 1240.005 9         | anello seeger/circlip                                                    | 1         | 1         |
| A 28+ | 6780.045 9         | prigioniero/stud M 8 X 12                                                | 1         | 1         |
| A 29  | 2175.125 104       | cartucc. sicur./saf. cartridge 5''                                       | 1         | 1         |
| A 30  | 6780.086 9         | prigioniero/stud M 8 x 65 (77)                                           | 2         | 2         |
| A 31  | 4420.019 560       | guarnizione/gasket                                                       | 2         | 2         |
| A 32  | 4500.079 276       | guarnizione/gasket                                                       | 1         | 1         |
| A 33  | 3815.013 276       | flangia scarico/exh.flange h=7,5                                         | 1         | 1         |
|       | 3815.022 625       | flangia scarico/exh.flange h= 7                                          | 1         | 1         |
| A 34  | 6780.005 9         | prigioniero/stud M 8 X 18 (30)                                           | 2         | 2         |
| A 36  | 3240.163 9         | dado/nut                                                                 | 2         | 2         |
| A 37  | 9170.050 435       | terminale/muffler-end (d.43,5/42)                                        | 1         | 1         |
| A 38  | 6491.031 104       | pipetta scarico/disch.elbow                                              | 1         | 1         |
| A 41  | 2100.055 904       | candeletta/preheating plug 12V                                           | 1         | 1         |
| A 42  | 6902.027 360       | flangia collettore/manifold flange                                       | 2         | 2         |
| A 43  | 2486.037 360       | collett.scar.2 uscite/exh.manifold                                       | 1         | 1         |
| A 44  | 4500.079 276       | guarnizione/exhaust gasket                                               | 1         | 1         |
| A 45  | 6300.018 277       | piastra chiusura/plate                                                   | 1         | 1         |
| A 47  | 5460.248 3600      | marmitta silenziata/muffler                                              | 1         | 1         |
| A 48  | 8545.566 105       | staffa/bracket                                                           | 1         | 1         |
| A 49  | 6727.022 560       | prefiltro/cyclonic prefilter                                             | 1         | 1         |
| A 50  | 3617.058 560       | fascetta/clamp                                                           | 1         | 1         |
| A 51  | 3700.299 104       | filtro aria 5'' con cartucc.sicur.<br>5''dry air clean.with safety cart. | 1         | 1         |
| A 52  | 4776.062 904       | guarnizione/gasket                                                       | 1         | 1         |
| A 53  | 6780.049 9         | prigioniero/stud M 8 X 20 (36)                                           | 1         | 1         |
| A 54  | 4670.026 520       | guarniz. rame/copper gasket d.22                                         | 1         | 1         |
| A 55  | 8965.065 515       | tappo/plug                                                               | 1         | 1         |
| A 56+ | 6780.030 9         | prigioniero/stud M 8 X 70 (82)                                           | 2         | 2         |
| A 57  | 2486.031 560       | collettore scar./exhaust manifold                                        | 1         | 1         |
| A 58  | 7565.007 9         | rondella/washer                                                          | 4         | 4         |

Motore/Engine 12LD 435-2

" " 12LD 475-2



**12LD 435-2 - 12LD 475-2**  
vedi Tavola Ric./see Parts Table 1.5302.508

| Pos.                     | Matricola/Part No.    | Note/Remarks                          | 12LD435-2 | 12LD475-2 |
|--------------------------|-----------------------|---------------------------------------|-----------|-----------|
| A 59                     | 2940.087 276          | curva scarico/exhaust elbow           | 1         |           |
| A 60                     | 4500.079 276          | guarnizione/exhaust gasket            | 1         | 1         |
| A 63                     | ex 3703.046 360       | B -> da/from s.No.3019535-> CT 1810-> | v         | v         |
|                          | ex 3700.274 - - - - - | sostituito da/superseded by - - ->    | v         | v         |
|                          | -> 3700.272 475 I     | FILTRO ARIA monomassa filtrante       | 1         | 1         |
|                          |                       | AIR CLEANER with one filter.elem.     |           |           |
|                          | 3700.329 435          | FILTRO ARIA bimassa filtrante         | 1         | 1         |
|                          |                       | AIR CLEANER with double filt.elem.    |           |           |
| A 64                     | 5496.193 435 A        | massa filtr.poliur./filt.element      | 1         | 1         |
| A 65                     | 1261.073 292          | anello tenuta/seal ring               | 1         | 1         |
|                          | 3525.090 270          | distanziale (filtro aria bimassa)     | 1         | 1         |
|                          |                       | spacer(air clean.with upper f.el.)    |           |           |
| A 66                     | 3240.018 9            | dado/nut                              | 3         | 3         |
| A 67                     | 7565.007 9            | rondella/washer                       | 3         | 3         |
| A 68                     | 9732.064 9            | vite/screw M 8 X 1,25 X '30           | 2         | 2         |
| A 69                     | 2486.079 435          | collettore asp./inlet manifold        | 1         | 1         |
| A 70                     | 3240.018 9            | dado/nut                              | 4         | 4         |
| A 71                     | 8965.071 9            | tappo/plug M 22                       | 1         | 1         |
| A 72                     | 3630.023 9            | fascetta/clamp                        | 1         | 1         |
| A 73                     | 2145.013 560          | cappuccio/cap                         | 1         | 1         |
| A 74                     | 2941.097 276          | curva scarico/exhaust elbow           | 1         |           |
| A 75                     | 9400.054 560          | tubo depr./suct.line (mm 135x8)       | 1         | 1         |
|                          | 9400.058 5600         | tubo depr./suct.line (mm 250x8)       | 1         | 1         |
|                          | 9400.035 276          | tubo depr./suct.line (mm 450x8)       | 1         | 1         |
|                          | 9400.040 276          | tubo depr./suct.line (mm 1200x10)     | 1         | 1         |
| A 76                     | 4420.020 560          | guarnizione/gasket                    | 2         | 2         |
| A 77                     | 9680.034 107          | valvola sfiato/breather valve         | 1         | 1         |
| A 78+                    | 6780.084 9            | prigioniero/stud M 8 X 40 (52)        | 2         | 2         |
|                          | 4770.032 291          | guarnizione/gasket                    | 1         | 1         |
| A 80                     | ex 5496.077 360       | B -> da/from s.No.3019535-> CT 1810-> | v         | v         |
|                          | -> 5496.111 292 A     | massa filtrante/filtering element     | 1         | 1         |
|                          | 5496.075 904          | massa filtr. (filtro aria bimassa)    | 1         | 1         |
|                          |                       | f.el. (air clean.with upper f.el.)    |           |           |
| A 81                     | 2486.310 560          | collettore asp.2 ingr./inlet manif    | 1         | 1         |
| A 82                     | 5460.424 435          | marmitta/muffler                      | 1         | 1         |
| A 83                     | 4115.048 276          | gancio/hook                           | 2         | 2         |
| A 84                     | 3781.027 904          | flangia/flange h= 7 mm d=40 mm        | 1         | 1         |
|                          | 3781.112 435          | flangia/flange h=14 mm d=50 mm        | 1         | 1         |
| A 85                     | 5460.221 360          | marmitta/muffler                      | 1         | 1         |
| A 86                     | 7300.091 276          | raccordo/connection                   | 1         | 1         |
|                          | 7301.126 560          | raccordo/connection (WACKER vers.)    | 1         | 1         |
| A 87                     | 8545.137 560          | staffa marmitta/muffler support       | 1         | 1         |
| A 88                     | 5460.291 560          | marmitta inclinata 1.vol./muffler     | 1         | 1         |
| A 89                     | 3781.080 629          | flangia/flange h= 8 mm d=50 mm        | 1         | 1         |
| A 90                     | 4889.015 560          | separator/breather cap                | 1         | 1         |
| A 91                     | 4670.014 276          | guarnizione/copper gasket             | 1         | 1         |
| A 93                     | 5460.326 360          | marmitta inclinata l.p.m./muffler     | 1         | 1         |
| A 94                     | 6927.128 276          | protezione marm./muffler guard        | 1         | 1         |
| A 95                     | 2486.052 560          | collettore scar./exhaust manifold     | 1         | 1         |
| A 96                     | 5460.472 435          | marmitta collettore/muffler-manif     | 1         | 1         |
| A 97                     | 2942.028 710          | curva aspirazione/inlet elbow         | 1         | 1         |
| A 98                     | 9400.090 360          | tubo depr./suction line (mm 305)      | 1         | 1         |
| B 1                      | =6500.315 435         | PISTONE COMPLETO/PISTON SET std.      | 2         |           |
|                          | =6500.316 435         | PISTONE COMPLETO/PISTON SET +0,50     | 2         |           |
|                          | =6500.317 435         | PISTONE COMPLETO/PISTON SET +1,00     | 2         |           |
|                          | =6500.700 475         | PISTONE COMPLETO/PISTON SET std.      |           | 2         |
|                          | =6500.701 475         | PISTONE COMPLETO/PISTON SET +0,50     |           | 2         |
|                          | =6500.702 475         | PISTONE COMPLETO/PISTON SET +1,00     |           | 2         |
|                          |                       | (Pos. 1-2-3-4)                        |           |           |
| Motore/Engine 12LD 435-2 |                       |                                       |           |           |
| " " 12LD 475-2           |                       |                                       |           |           |



**12LD 435-2 - 12LD 475-2**  
**vedi Tavola Ric./see Parts Table 1.5302.508**

| Pos.  | Matricola/Part No.    | Note/Remarks                                           | 12LD435-2 | 12LD475-2 |
|-------|-----------------------|--------------------------------------------------------|-----------|-----------|
| B 2+  | ex 8211.071 395 B     | -> dal/from 10.04.1987-> CT 1803->                     | v         |           |
|       | ex 8211.088 - - - - - | sostituito da/superseded by - - ->                     | v         |           |
|       | -> 8211.203 435 I     | serie segmenti/ring set std.                           | 2         |           |
|       | ex 8211.072 395 B     | -> dal/from 10.04.1987-> CT 1803->                     | v         |           |
|       | ex 8211.089 - - - - - | sostituito da/superseded by - - ->                     | v         |           |
|       | -> 8211.204 435 I     | serie segmenti/ring set +0,50                          | 2         |           |
|       | ex 8211.073 395 B     | -> dal/from 10.04.1987-> CT 1803->                     | v         |           |
|       | -> 8211.090 435 I     | serie segmenti/ring set +1,00                          | 2         |           |
|       | ex 8211.082 - - - - - | sostituito da/superseded by - - ->                     | v         |           |
|       | > 8211.200 567 I      | serie segmenti/ring set std.                           | 2         |           |
|       | ex 8211.083 - - - - - | sostituito da/superseded by - - ->                     | v         |           |
|       | -> 8211.207 567 I     | serie segmenti/ring set +0,50                          | 2         |           |
|       | ex 8211.084 - - - - - | sostituito da/superseded by - - ->                     | v         |           |
|       | -> 8211.208 567 I     | serie segmenti/ring set +1,00                          | 2         |           |
| B 3+  | 1241.002 9            | anello seeger/snap ring                                | 4         |           |
|       | 1160.053 475          | anello tenuta/circlip                                  | 4         |           |
| B 4+  | 8480.050 435          | spinotto/gudgeon pin                                   | 2         |           |
|       | 8480.053 475          | spinotto/gudgeon pin                                   | 2         |           |
| B 5+  | 1630.018 435          | br.piede biella/small end bushing                      | 2         |           |
| B 6   | =1526.098 435         | BIELLA COMPLETA/CONNECTING ROD<br>(Pos. 5-6-21)        | 2         | 2         |
| B 7   | 1640.082 435          | br. biella/large end bushing std.                      | 2         | 2         |
|       | 1640.083 435          | br. biella/large end bushing -0,25                     | 2         | 2         |
|       | 1640.084 435          | br. biella/large end bushing -0,50                     | 2         | 2         |
| B 8   | ex 1050.284 - - (npd) | -> da/from s.No.3574322-> CT 120007->                  | v         | v         |
|       | ->=1050.903 435 A     | ALBERO A GOMITO/CRANKSHAFT<br>(Pos. 8-26-27)           | 1         | 1         |
| B 10  | 4701.058 360          | guarnizione/gasket 0,30                                | 1         | 1         |
|       | 4701.059 360          | guarnizione/gasket 0,50                                | 1         | 1         |
| B 11  | 1611.055 560          | br.suppl.serb./tank s.bear. std.                       | 1         | 1         |
|       | 1611.054 560          | br.suppl.serb./tank s.bear.-0,25                       | 1         | 1         |
|       | 1611.053 560          | br.suppl.serb./tank s.bear.-0,50                       | 1         | 1         |
| B 12  | ex 1770.154 - - - - - | sostituito da/superseded by - - ->                     | v         | v         |
|       | -> 1770.156 9 A       | bullone/bolt M 8 X 1,25 X 25                           | 6         | 6         |
| B 13  | ex 8676.090 - - (npd) | -> da/from s.No.3574322-> CT 120007->                  | v         | v         |
|       | -> 8675.277 435 A     | supporto/support                                       | 1         | 1         |
| B 14  | 2280.085 9            | chiavetta/key 9,52x9,52x85                             | 1         | 1         |
| B 15  | 6902.039 360          | prolunga cilindrica/paral.extens.                      | 1         | 1         |
| B 17+ | 6850.124 435          | prigioniero/stud                                       | 8         | 8         |
| B 18  | ex 2380.214 435 B     | -> da/from s.No.3917191-> CT 120008->                  | v         |           |
|       | -> 2380.573 435 A     | cilindro/cylinder                                      | 2         |           |
|       | ex 2380.297 475 B     | -> da/from s.No.3914324-> CT 120009->                  | v         |           |
|       | -> 2380.574 475 A     | cilindro/cylinder                                      | 2         |           |
| B 19  | ex 1510.222 - - (npd) | -> da/from s.No.3528962-> CT 120006->                  | v         |           |
|       | ex 1510.709 435 B     | -> da/from s.No.3917191-> CT 120008->                  | v         |           |
|       | ->=1510.710 475 A     | BASAMENTO/CRANKCASE                                    | 1         |           |
|       | ex 1510.473 - - (npd) | -> da/from s.No.3528962-> CT 120006->                  | v         |           |
|       | ->=1510.710 475 A     | BASAMENTO/CRANKCASE<br>(Pos. 17-19-22-23-31-E 56-E137) | 1         |           |
| B 21+ | 1770.101 9            | bullone/bolt                                           | 4         | 4         |
| B 22+ | 9765.111 9            | vite/screw                                             | 1         | 1         |
| B 23+ | 9000.072 360          | tappo/expansion cap                                    | 1         | 1         |
| B 24  | 4936.035 360          | ingranaggio/gearwheel                                  | 1         | 1         |

Motore/Engine 12LD 435-2  
 " " 12LD 475-2



| 12LD 435-2 - 12LD 475-2<br>vedi Tavola Ric./see Parts Table 1.5302.508 |                       | 12LD435-2                                                                                            | 12LD475-2 |
|------------------------------------------------------------------------|-----------------------|------------------------------------------------------------------------------------------------------|-----------|
| Pos.                                                                   | Matricola/Part No.    | Note/Remarks                                                                                         |           |
| B 25                                                                   | 8675.266 560          | supp.l.distr./gear s.support std.                                                                    | 1 1       |
| "                                                                      | 8675.267 560          | supp.l.distr./gear s.support -0,25                                                                   | 1 1       |
| "                                                                      | 8675.268 560          | supp.l.distr./gear s.support -0,50                                                                   | 1 1       |
| B 26+                                                                  | 2280.056 9            | chiavetta/key                                                                                        | 2 2       |
| B 27+                                                                  | ex 9000.028 - - - - - | sostituito da/superseded by - - - - -                                                                | v v       |
|                                                                        | -> 9080.133 516 I     | tappo/cap                                                                                            | 4 4       |
| B 28                                                                   | ex 1210.079 9 B       | -> da/from s.No.3574322-> CT 120007->                                                                | v v       |
|                                                                        | -> 1213.347 107 A     | anello tenuta/seal ring 70X88X8                                                                      | 1 1       |
| B 29                                                                   | 5055.026 360          | lamiera/panel                                                                                        | 1 1       |
| B 30                                                                   | 1760.001 9            | bullone/bolt M 6 X 1 X 10                                                                            | 2 2       |
| B 31+                                                                  | 9080.083 9            | tappo/cap                                                                                            | 1 1       |
| B 32                                                                   | 1805.025 9            | bullone/bolt                                                                                         | 1 1       |
| B 33                                                                   | 7626.033 360          | rondella/washer                                                                                      | 1 1       |
| B 34                                                                   | ex 1770.005 9 B       | -> da/from s.No.3528962-> CT 120006->                                                                | v v       |
|                                                                        | ex 1770.154 - - - - - | sostituito da/superseded by - - - - -                                                                | v v       |
|                                                                        | -> 1770.156 9 A       | bullone/bolt M 8 X 1,25 X 25                                                                         | 2 2       |
| B 35                                                                   | ex 7625.012 9 B       | -> fino a/until 3528961-> CT 120006                                                                  | v v       |
| B 37                                                                   | =8676.055 360         | SUPPORTO CENTRALE/MIDDLE SUPPORT<br>(Pos. 37-46)                                                     | 1 1       |
| B 38                                                                   | 1610.082 904          | br.cent./middle supp.bear. std.                                                                      | 1 1       |
| "                                                                      | 1610.098 904          | br.cent./middle supp.bear. -0,25                                                                     | 1 1       |
| "                                                                      | 1610.099 904          | br.cent./middle supp.bear. -0,50                                                                     | 1 1       |
| B 39+                                                                  | 2816.052 435          | corona avviamento/crown gear                                                                         | 1 1       |
| B 42                                                                   | ex 9880.300 435 B     | -> da/from s.No.3053960-> CT 1814->                                                                  | v         |
|                                                                        | ->=9880.639 435 A     | VOLANO con CORONA/FLYWH.with CROWN<br>per/for 12LD 435-2 industr./gr.el.                             | 1 -       |
| "                                                                      | ex 9880.279 435 B     | -> da/from s.No.3053960-> CT 1814->                                                                  | v         |
|                                                                        | ->=9880.554 435 A     | VOLANO con CORONA/FLYWH.with CROWN<br>per/for 12LD 435-2 automotive<br>,, 12LD 475-2<br>(Pos. 39-42) | 1 1       |
| B 43                                                                   | 7565.011 9            | rondella/washer                                                                                      | 16 16     |
| B 44                                                                   | 1780.007 9            | bullone/bolt M 10 X 1,5 X 35                                                                         | 16 16     |
| B 45                                                                   | ex 6780.005 9 B       | -> fino a/until 3528961-> CT 120006                                                                  | v v       |
| B 46+                                                                  | 9732.075 9            | vite/screw M 8 X 1,25 X 50                                                                           | 2 2       |
| B 47                                                                   | 5111.069 560          | lamierino/safety plate                                                                               | 1 1       |
| B 48                                                                   | 1862.144 560          | bullone/bolt                                                                                         | 1 1       |
| B 49                                                                   | ex 1212.006 9 B       | -> da/from s.No.3574322-> CT 120007->                                                                | v v       |
|                                                                        | -> 1213.321 560 A     | anello OR/rubber oil seal                                                                            | 1 1       |
| B 50                                                                   | ex 8900.168 435 B     | -> da/from s.No.3053960-> CT 1814->                                                                  | v v       |
|                                                                        | ex 8900.291 - - - - - | sostituito da/superseded by - - - - -                                                                | v v       |
|                                                                        | -> 8900.470 475 A     | supporto/support                                                                                     | 1 1       |
| B 51                                                                   | 9732.074 9            | vite/screw M 8 X 1,25 X 20                                                                           | 2 2       |
| B 52                                                                   | 9730.035 9            | vite/screw M 8 X 1,25 X 65                                                                           | 2 2       |
| B 53+                                                                  | 8460.055 276          | spina/taper pin                                                                                      | 2 2       |
| B 55                                                                   | 4701.041 360          | guarnizione/gasket                                                                                   | 1 1       |
| B 56                                                                   | 2751.096 560          | coperchio/cover                                                                                      | 1 1       |
| B 57                                                                   | 6429.033 560          | piede/engine mount                                                                                   | 4 4       |
| B 58                                                                   | 2615.075 435          | coperchio/cover                                                                                      | 1 1       |
| B 59                                                                   | 1200.174 9            | anello OR/rubber oil seal                                                                            | 1 1       |
| B 60                                                                   | 4776.087 560          | guarnizione/gasket                                                                                   | 1 1       |
| B 61                                                                   | 7625.010 9            | rondella/washer                                                                                      | 3 3       |
| B 62                                                                   | 3240.018 9            | dado/nut                                                                                             | 3 3       |
| B 63                                                                   | 9730.034 9            | vite/screw M 8 X 1,25 X 55                                                                           | 1 1       |
| B 64                                                                   | .....                 | vedi/see Pos. F 90                                                                                   |           |
| B 65                                                                   | 6429.174 435          | piede speciale/eng.mount (KAESER)                                                                    | 4         |
| B 66                                                                   | 1198.097 360          | anello di flangiatura/flang.ring                                                                     | 1 1       |
| Motore/Engine 12LD 435-2                                               |                       |                                                                                                      |           |
| " " 12LD 475-2                                                         |                       |                                                                                                      |           |

| 12LD 435-2 - 12LD 475-2<br>vedi Tavola Ric./see Parts Table 1.5302.508 |                                               |                                                                                                                                                            |  | 12LD435-2 | 12LD475-2 |
|------------------------------------------------------------------------|-----------------------------------------------|------------------------------------------------------------------------------------------------------------------------------------------------------------|--|-----------|-----------|
| Pos.                                                                   | Matricola/Part No.                            | Note/Remarks                                                                                                                                               |  |           |           |
| B 67                                                                   | 6900.074 360                                  | prolunga conica/conical extension                                                                                                                          |  | 1         | 1         |
| B 68                                                                   | 1662.012 291                                  | bullone blocc.flangiatura/bolt M14                                                                                                                         |  | 1         | 1         |
| C 1                                                                    | 8506.003 904                                  | squadretta/angle bracket                                                                                                                                   |  | 2         | 2         |
| C 2                                                                    | 9732.075 9                                    | vite/screw M 8 X 1,25 X 50                                                                                                                                 |  | 4         | 4         |
| C 3                                                                    | ex 9032.064 560 B<br>->=9032.079 104 A        | -> da/from s.No.4055925-> CT 120011-><br>TAPPO RIF.OLIO/OIL FILLER CAP<br>(Pos. 3-4)                                                                       |  | v         | v         |
| C 4+                                                                   | 1200.015 9                                    | anello OR/rubber oil seal                                                                                                                                  |  | 1         | 1         |
| C 5                                                                    | ex 2125.093 560 E B<br>-> 2125.338 560 A      | -> da/from s.No.4055925-> CT 120011-><br>cappello con foro/cap with hole                                                                                   |  | v         | v         |
| C 6                                                                    | =2125.100 560 A                               | CAPPELLO CON FORO e compl.decompr.:<br>ROCKER COVER FRONT with compr.rel.<br>(Pos. 6-11-12-23-24-27-28-31-32)                                              |  | 1         | 1         |
| C 7                                                                    | =9032.064 560                                 | TAPPO RIFORNIMENTO/FILLER OIL CAP<br>(Pos. 7-8)                                                                                                            |  | 1         | 1         |
| C 8+                                                                   | 1200.015 9                                    | anello OR/rubber oil seal                                                                                                                                  |  | 1         | 1         |
| C 9                                                                    | 4670.014 276                                  | guarnizione rame/copper gasket                                                                                                                             |  | 1         | 1         |
| C 10                                                                   | 9000.064 9                                    | tappo/plug                                                                                                                                                 |  | 1         | 1         |
| C 11+                                                                  | .....                                         | vedi/see Pos. C 6/C 21                                                                                                                                     |  |           |           |
| C 12+                                                                  | 8430.005 9                                    | spina/lockpin                                                                                                                                              |  | 2         | 2         |
| C 13                                                                   | ex 2125.094 - - (npd) -><br>-> 2125.339 560 I | -> da/from s.No.4055925-> CT 120011-><br>cappello bil./rocker box cap                                                                                      |  | v         | v         |
| C 14                                                                   | 4400.061 560                                  | guarnizione/gasket 0,80                                                                                                                                    |  | 2         | 2         |
| C 15+                                                                  | 9730.100 9                                    | vite/screw M 8 X 1,25 X 25                                                                                                                                 |  | 4         | 4         |
| C 16+                                                                  | 7565.007 9                                    | rondella/washer                                                                                                                                            |  | 4         | 4         |
| C 17                                                                   | =4330.036 560<br>,, =4330.064 560             | GR.BILANC./ROCKER ARM ASS.Y std<br>GR.BIL./R.ARM ASS.Y 1500/1800 rpm<br>(Pos. 15-16-17-18-19-36-37-38)                                                     |  | 2         | 2         |
| C 18+                                                                  | 3240.010 9                                    | dado/nut                                                                                                                                                   |  | 4         | 4         |
| C 19+                                                                  | 9850.002 270                                  | vite/screw                                                                                                                                                 |  | 4         | 4         |
| C 20+                                                                  | 6410.018 260                                  | piattello/retainer with half-coll                                                                                                                          |  | 4         | 4         |
| C 21                                                                   | =2125.101 560 A                               | CAPPELLO compl.di decompressione<br>ROCKER COVER with compress.release<br>(Pos. 11-12-21-23-24-27-28-31-32)                                                |  | 1         | 1         |
| C 22                                                                   | 4400.061 560                                  | guarnizione/gasket 0,80                                                                                                                                    |  | 2         | 2         |
| C 23+                                                                  | 1200.034 9                                    | anello OR 105/rubber oil seal                                                                                                                              |  | 2         | 2         |
| C 24+                                                                  | 6095.010 560                                  | perno con eccentrico/shaft                                                                                                                                 |  | 2         | 2         |
| C 25                                                                   | =4330.037 560<br>,, =4330.063 560             | per decompress./for compr.release<br>per dec.(motori a 1500/1800 G/l)<br>for compr.rel. (1500/1800 rpm eng)<br>(Pos. 15-16-25-29-30-33-34-35-36-<br>37-38) |  | 2         | 2         |
| C 26                                                                   | 7625.108 625                                  | rondella/washer                                                                                                                                            |  | 2         | 2         |
| C 27+                                                                  | 9820.085 560                                  | vite fermo/fixing screw                                                                                                                                    |  | 2         | 2         |
| C 28+                                                                  | 8430.004 9                                    | spina/lockpin                                                                                                                                              |  | 2         | 2         |
| C 29+                                                                  | 6372.098 560                                  | piastrina/plate                                                                                                                                            |  | 2         | 2         |
| C 30+                                                                  | 9850.002 270                                  | vite/screw                                                                                                                                                 |  | 4         | 4         |
| Motore/Engine 12LD 435-2                                               |                                               |                                                                                                                                                            |  |           |           |
| ,, ,, 12LD 475-2                                                       |                                               |                                                                                                                                                            |  |           |           |



**12LD 435-2 - 12LD 475-2**  
**vedi Tavola Ric./see Parts Table 1.5302.508**

| Pos.  | Matricola/Part No.    | Note/Remarks                                                                                                                                | 12LD 435-2 | 12LD 475-2 |
|-------|-----------------------|---------------------------------------------------------------------------------------------------------------------------------------------|------------|------------|
| C 31+ | 5780.011 904          | molla/spring                                                                                                                                | 2          | 2          |
| C 32+ | 8245.005 9            | sfera/ball                                                                                                                                  | 2          | 2          |
| C 33+ | 3240.010 9            | dado/nut                                                                                                                                    | 4          | 4          |
| C 34+ | 8335.084 276          | spessore/shim                                                                                                                               | 2          | 2          |
| C 35+ | 8335.028 276          | spessore/shim                                                                                                                               | 8          | 8          |
| C 36+ | 6045.040 560          | perno/pin                                                                                                                                   | 2          | 2          |
| C 37+ | 1350.011 560          | anello/ring                                                                                                                                 | 2          | 2          |
| C 38+ | 9455.053 560          | tubo lubrificazione/lub.pipe                                                                                                                | 2          | 2          |
| C 39+ | ex 2135.072 500 B     | -> da/from s.No.3474289-> CT 120005->                                                                                                       | v          | v          |
|       | -> 1213.338 560 A     | anello tenuta/seal ring                                                                                                                     | 2          | 2          |
| C 40+ | 1160.021 710          | anello/sirclip                                                                                                                              | 4          | 4          |
| C 41+ | ex 4845.118 - - (npd) | -> dal/from 20.04.1988-> CT 1806->                                                                                                          | v          | v          |
|       | ex 4845.180 - - (npd) | -> da/from s.No.3014752-> CT 1812->                                                                                                         | v          | v          |
|       | ex 4845.182 560 B     | -> da/from s.No.3474289-> CT 120005->                                                                                                       | v          | v          |
|       | -> 4845.230 560 A     | guida v.asp./inlet v.guide std.                                                                                                             | 2          | 2          |
|       | ex 4845.181 629 E     | -> da/from s.No.3014752-> CT 1812->                                                                                                         | v          | v          |
|       | ex 4845.183 560 B     | -> da/from s.No.3474289-> CT 120005->                                                                                                       | v          | v          |
|       | -> 4845.231 560 A     | guida v.asp./inlet v.guide +0,50                                                                                                            | 2          | 2          |
| C 42+ | 9652.061 435          | valvola aspirazione/inlet valve                                                                                                             | 2          | 2          |
| C 43+ | ex 4845.114 (npd)     | -> dal/from 20.04.1988-> CT 1807->                                                                                                          | v          | v          |
|       | -> 4845.184 629 I     | guida v.scar./exh. v.guide std.                                                                                                             | 2          | 2          |
|       | ex .....              | -> dal/from 20.04.1988-> CT 1807->                                                                                                          | v          | v          |
|       | -> 4845.185 629 I     | guida v.scar./exh. v.guide +0,50                                                                                                            | 2          | 2          |
| C 44+ | 9685.067 435          | valvola scarico/exhaust valve                                                                                                               | 2          | 2          |
| C 45+ | ex 5755.065 - - - -   | sostituito da/superseded by - - ->                                                                                                          | v          | v          |
|       | -> 5755.004 260 I     | molla/spring                                                                                                                                | 4          | 4          |
| C 46  | 4740.029 625          | guarnizione/gasket                                                                                                                          | 2          | 2          |
| C 47+ | 3430.067 710          | dischetto/retainer                                                                                                                          | 4          | 4          |
| C 48  | 3240.124 9            | dado/nut                                                                                                                                    | 8          | 8          |
| C 49  | 7625.196 9            | rondella/washer                                                                                                                             | 8          | 8          |
| C 50  | ex 3300.100 - - - -   | sostituito da/superseded by - - ->                                                                                                          | v          | v          |
|       | -> 3300.227 560 I     | dado/nut                                                                                                                                    | 2          | 2          |
| C 51  | ex .....              | -> da/from s.No.3396161-> CT 120004->                                                                                                       | v          | v          |
|       | ->=5200.854 560 A     | LEVA COM.REG./GOVERNOR LEVER ASS.Y<br>(Pos. 51-52-62-67-68-72-85)                                                                           | 1          | 1          |
| C 52+ | 7626.040 9            | rondella/washer                                                                                                                             | 1          | 1          |
| C 53  | ex 9200.243 435 B     | -> da/from s.No.3917191-> CT 120008->                                                                                                       | v          | v          |
|       | ->=9200.245 629 A     | -> da/from s.No.3914324-> CT 120009-><br>TESTA COMPLETA/CYLINDER HEAD<br>(Pos. 20-39-40-41-42-43-44-45-47-<br>53-63-65-A 16-A 56-A 78-E 16) | 2          | 2          |
| C 54  | 9520.055 435          | tubo protez./guard tube                                                                                                                     | 2          | 2          |

Motore/Engine 12LD 435-2  
 " " 12LD 475-2

| 12LD 435-2 - 12LD 475-2<br>vedi Tavola Ric./see Parts Table 1.5302.508 |                       | 12LD435-2                                                                                                                                            | 12LD475-2 |
|------------------------------------------------------------------------|-----------------------|------------------------------------------------------------------------------------------------------------------------------------------------------|-----------|
| Pos.                                                                   | Matricola/Part No.    | Note/Remarks                                                                                                                                         |           |
| C 55                                                                   | ex 4730.384 395       | B -> da/from s.No.3917191-> CT 120008->                                                                                                              | v         |
|                                                                        | -> 4730.571 435       | A guarnizione testa/head gasket 0,50                                                                                                                 | v         |
|                                                                        | ex 4730.186 395       | B -> da/from s.No.3917191-> CT 120008->                                                                                                              | v         |
|                                                                        | -> 4730.572 435       | A guarnizione testa/head gasket 0,55                                                                                                                 | v         |
|                                                                        | ex 4730.089 395       | B -> da/from s.No.3917191-> CT 120008->                                                                                                              | v         |
|                                                                        | -> 4730.573 435       | A guarnizione testa/head gasket 0,60                                                                                                                 | v         |
|                                                                        | ex 4730.187 395       | B -> da/from s.No.3917191-> CT 120008->                                                                                                              | v         |
|                                                                        | -> 4730.574 435       | A guarnizione testa/head gasket 0,65                                                                                                                 | v         |
|                                                                        | ex 4730.090 395       | B -> da/from s.No.3917191-> CT 120008->                                                                                                              | v         |
|                                                                        | -> 4730.575 435       | A guarnizione testa/head gasket 0,70                                                                                                                 | v         |
|                                                                        | ex 4730.188 395       | B -> da/from s.No.3917191-> CT 120008->                                                                                                              | v         |
|                                                                        | -> 4730.576 435       | A guarnizione testa/head gasket 0,75                                                                                                                 | v         |
|                                                                        | ex 4730.091 395       | B -> da/from s.No.3917191-> CT 120008->                                                                                                              | v         |
|                                                                        | -> 4730.577 435       | A guarnizione testa/head gasket 0,80                                                                                                                 | v         |
|                                                                        | ex 4730.189 395       | B -> da/from s.No.3917191-> CT 120008->                                                                                                              | v         |
|                                                                        | -> 4730.578 435       | A guarnizione testa/head gasket 0,85                                                                                                                 | v         |
|                                                                        | ex 4730.092 395       | B -> da/from s.No.3917191-> CT 120008->                                                                                                              | v         |
|                                                                        | -> 4730.579 435       | A guarnizione testa/head gasket 0,90                                                                                                                 | v         |
|                                                                        | ex 4730.190 395       | D -> da/from s.No.3917191-> CT 120008->                                                                                                              | v         |
|                                                                        | -> 4730.580 435       | A guarnizione testa/head gasket 0,95                                                                                                                 | v         |
|                                                                        | ex 4730.246 560       | B -> da/from s.No.3914324-> CT 120009->                                                                                                              | v         |
|                                                                        | -> 4730.560 475       | A guarnizione testa/head gasket 0,50                                                                                                                 | v         |
|                                                                        | ex 4730.247 560       | B -> da/from s.No.3914324-> CT 120009->                                                                                                              | v         |
|                                                                        | -> 4730.561 475       | A guarnizione testa/head gasket 0,55                                                                                                                 | v         |
|                                                                        | ex 4730.054 560       | B -> da/from s.No.3914324-> CT 120009->                                                                                                              | v         |
|                                                                        | -> 4730.562 475       | A guarnizione testa/head gasket 0,60                                                                                                                 | v         |
|                                                                        | ex 4730.248 560       | B -> da/from s.No.3914324-> CT 120009->                                                                                                              | v         |
|                                                                        | -> 4730.563 475       | A guarnizione testa/head gasket 0,65                                                                                                                 | v         |
|                                                                        | ex 4730.071 560       | B -> da/from s.No.3914324-> CT 120009->                                                                                                              | v         |
|                                                                        | -> 4730.564 475       | A guarnizione testa/head gasket 0,70                                                                                                                 | v         |
|                                                                        | ex 4730.249 560       | B -> da/from s.No.3914324-> CT 120009->                                                                                                              | v         |
|                                                                        | -> 4730.565 475       | A guarnizione testa/head gasket 0,75                                                                                                                 | v         |
|                                                                        | ex 4730.050 560       | B -> da/from s.No.3914324-> CT 120009->                                                                                                              | v         |
|                                                                        | -> 4730.566 475       | A guarnizione testa/head gasket 0,80                                                                                                                 | v         |
|                                                                        | ex 4730.250 560       | B -> da/from s.No.3914324-> CT 120009->                                                                                                              | v         |
|                                                                        | -> 4730.567 475       | A guarnizione testa/head gasket 0,85                                                                                                                 | v         |
|                                                                        | ex 4730.070 560       | B -> da/from s.No.3914324-> CT 120009->                                                                                                              | v         |
|                                                                        | -> 4730.568 475       | A guarnizione testa/head gasket 0,90                                                                                                                 | v         |
|                                                                        | ex 4730.251 560       | B -> da/from s.No.3914324-> CT 120009->                                                                                                              | v         |
|                                                                        | -> 4730.569 475       | A guarnizione testa/head gasket 0,95                                                                                                                 | v         |
| C 56                                                                   | 4740.029 625          | guarnizione/gasket                                                                                                                                   | v         |
| C 57                                                                   | ex 1410.085 - - (npd) | -> da/from s.No.2809667-> CT 1804->                                                                                                                  | v         |
|                                                                        | -> 1410.088 435       | I asta punteria/pushrod                                                                                                                              | v         |
| C 58                                                                   | 7215.043 904          | punteria/tappet                                                                                                                                      | v         |
| C 59                                                                   | 1011.085 560          | albero camme/camshaft 3600 rpm                                                                                                                       | v         |
|                                                                        | 1011.110 435          | albero camme/camshaft 3000 rpm                                                                                                                       | v         |
| C 60                                                                   | ex 8180.062 395       | B -> da/from s.No.3917191-> CT 120008->                                                                                                              | v         |
|                                                                        | ->=8180.196 435       | A SERIE GUARNIZIONI/GASKET SET                                                                                                                       | v         |
|                                                                        | ex 8180.164 475       | B -> da/from s.No.3914324-> CT 120009->                                                                                                              | v         |
|                                                                        | ->=8180.197 475       | A SERIE GUARNIZIONI/GASKET SET<br>(Pos.A 31-A 52-A 76-B 10-B 55-<br>C 14-C 55-D 42-D 60-D126-<br>D 135)                                              | v         |
| C 61                                                                   | ex=8185.027 435       | B -> fino/until 3917190-> CT 120008<br>(Pos.A 31-A 32-A 52-A 76-B 55-<br>C 4-C 14-C 23-C 39-C 46-<br>C 56-E 2-E 4-E 18-E 19-<br>E 32-E 63-E111-E141) | v         |
| Motore/Engine 12LD 435-2                                               |                       |                                                                                                                                                      |           |
| " " 12LD 475-2                                                         |                       |                                                                                                                                                      |           |



**12LD 435-2 - 12LD 475-2**  
**vedi Tavola Ric./see Parts Table 1.5302.508**

| Pos.  | Matricola/Part No.    | Note/Remarks                                                   | 12LD 435-2 | 12LD 475-2 |
|-------|-----------------------|----------------------------------------------------------------|------------|------------|
| C 62+ | 1240.077 9            | anello seeger/snap ring                                        | 1          | 1          |
| C 63+ | 8000.065 560          | sede v.aspiraz./inlet v.seat                                   | 2          | 2          |
| C 64  | ex 1770.006 9 B       | -> da/from s.No.3528962-> CT 120006->                          | v          | v          |
|       | -> 1770.150 9 A       | bullone/bolt M 8 X 1,25 X 22                                   | 2          | 2          |
| C 65+ | 8000.066 560          | sede v.scarico/exhaust v.seat                                  | 2          | 2          |
| C 66  | ex 7555.029 9 B       | -> fino a/until 3528961-> CT 120006                            | v          | v          |
| C 67+ | 1240.005 9            | anello seeger/snap ring                                        | 1          | 1          |
| C 68+ | 7626.040 9            | rondella/washer                                                | 1          | 1          |
| C 69  | 2280.047 9            | chiavetta/key                                                  | 1          | 1          |
| C 70  | ex 7362.160 - - (npd) | -> da/from s.No.3396161-> CT 120004->                          | v          | v          |
|       | -> 7362.277 560 A     | REGOLAT.GIRI/SPEED GOV. < 3000 rpm                             | 1          | 1          |
|       | ex 7362.186 - - (npd) | -> da/from s.No.3396161-> CT 120004->                          | v          | v          |
|       | =7362.278 435         | REGOLAT.GIRI/SPEED GOV. > 3000 rpm<br>(Pos. 70-71-73)          | 1          | 1          |
| C 71+ | ex 2086.084 - - (npd) | -> da/from s.No.3396161-> CT 120004->                          | v          | v          |
|       | -> 2086.140 560 A     | campana/speed governor bell                                    | 1          | 1          |
| C 72+ | 7625.007 9            | rondella/washer                                                | 1          | 1          |
| C 73+ | 1160.022 560          | anello tenuta/circlip                                          | 1          | 1          |
| C 76  | ex 3110.058 9 B       | -> fino a/until 3396160-> CT 120004                            | v          | v          |
| C 77  | =8785.069 560         | SUPPORTO LEVA/GOV.YOKE SUPPORT<br>(Pos. 77-78)                 | 1          | 1          |
| C 78+ | 1585.025 9            | boccola/bushing                                                | 2          | 2          |
| C 79  | 7626.040 9            | rondella/washer                                                | 1          | 1          |
| C 80  | 1240.077 9            | anello seeger/snap ring                                        | 1          | 1          |
| C 83  | 1780.059 9            | bullone/bolt M 10 X 1,5 X 35                                   | 1          | 1          |
| C 84  | 7626.038 9            | rondella/washer                                                | 1          | 1          |
| C 85+ | 9730.107 9            | vite/screw M 6 X 1 X 14                                        | 1          | 1          |
| C 86  | ex 5200.300 - - (npd) | -> da/from s.No.3396161-> CT 120004->                          | v          | v          |
|       | -> vedi/see Pos. C 51 |                                                                |            |            |
| C 87+ | 7625.007 9            | rondella/washer                                                | 1          | 1          |
| C 88  | 6080.022 560          | perno/pin                                                      | 1          | 1          |
| C 89  | =8150.017 475         | SERIE ANELLI/O RING SET<br>(Pos.B 59-C 39-C 46-C 56-D 24-E136) | 1          | 1          |
| C 90  | .....                 | vedi/see Pos. D 29                                             |            |            |
| C 91  | 5801.153 625          | molla/spring                                                   | 2          | 2          |
| D 1   | 9060.008 500          | tappo/cap M 14                                                 | 1          | 1          |
| D 2   | 1770.042 9            | bullone/bolt M 8 X 1,25 X 10                                   | 1          | 1          |
| D 3   | 4670.058 9            | guarnizione/copper gasket                                      | 1          | 1          |
| D 4   | 9680.013 560          | valvola pressione/pressure valve                               | 1          | 1          |
| D 5   | 5755.049 500          | molla/spring                                                   | 1          | 1          |
| D 6   | 9070.012 500          | tappo/cap                                                      | 1          | 1          |

Motore/Engine 12LD 435-2 .....  
 ,, ,, 12LD 475-2 .....

| 12LD 435-2 - 12LD 475-2<br>vedi Tavola Ric./see Parts Table 1.5302.508 |                                                           |                                                                                                                                                                                                                                                            |             | 12LD435-2   | 12LD475-2 |
|------------------------------------------------------------------------|-----------------------------------------------------------|------------------------------------------------------------------------------------------------------------------------------------------------------------------------------------------------------------------------------------------------------------|-------------|-------------|-----------|
| Pos.                                                                   | Matricola/Part No.                                        | Note/Remarks                                                                                                                                                                                                                                               |             |             |           |
| D 7                                                                    | =2516.061 560                                             | COMANDO ACC.DISTANZA-STOP A MANO<br>per comando con molla regolatore<br>su gruppi elettrogeni<br>REMOTE ACCELER.CONTROL-HAND STOP<br>for engine with control spring<br>fitted on generating sets<br>(Pos. 7-14-15-16-17-21-22-47-48-<br>76-78-80-83-84-89) | 1           | 1           |           |
| ..                                                                     | =2516.109 560                                             | COMANDO ACC.DISTANZA-STOP A MANO<br>per comando con bilancino<br>REMOTE ACCELER.CONTROL-HAND STOP<br>for engine with equal.rocker arm<br>(Pos. 7-14-15-16-17-21-22-47-48-<br>107-109-112-116-117-118)                                                      | 1           | 1           |           |
| ..                                                                     | =2516.114 560                                             | COMANDO ACC. E STOP A DISTANZA<br>per comando con bilancino<br>REMOTE ACCELER.AND STOP CONTROL<br>for engine with equal.rocker arm<br>(Pos. 7-14-15-16-17-22-23-47-48-<br>107-109-112-116-117-118)                                                         | 1           | 1           |           |
| ..                                                                     | =2516.182 560                                             | COMANDO ACC. E STOP A DISTANZA<br>per comando con bilancino (WACKER)<br>REMOTE ACCELER.AND STOP CONTROL<br>for engine with equal.rocker arm<br>(Pos. 7-14-15-16-17-22-23-47-48-<br>107-109-112-116-117-118)                                                | 1           |             |           |
| ..                                                                     | =2516.183 560                                             | COMANDO ACC./STOP con EL.MAGNETE<br>per comando con bilancino<br>REMOTE ACC./STOP with ELECTROMAGN<br>for engine with equal.rocker arm<br>(Pos. 7-14-15-16-17-22-47-48-75-<br>107-109-112-116-117-118)                                                     |             | 1           |           |
| D 8                                                                    | 3240.019 9                                                | dado ottone/nut M 8                                                                                                                                                                                                                                        | 2           | 2           |           |
| D 9                                                                    | 9180.042 276                                              | terminale/cable end                                                                                                                                                                                                                                        | 2           | 2           |           |
| D 11                                                                   | ex 8576.018 360 * B<br>->=8576.065 435 I<br>=8576.029 435 | -> da/from s.No.3143616-> CT 120002-><br>SUPPLEMENTO/EXTRA FUEL DEVICE<br>SUPPLEMENTO per STOP con EL.MAGNET<br>EXT. F.DEVICE (STOP with EL.MAGNET<br>(Pos. 11-40)                                                                                         | v<br>1<br>1 | v<br>1<br>1 |           |
| D 12                                                                   | ex .....                                                  | -> dal/from 05.04.1988 -> CT 1805-><br>prigioniero/stud M 8 X 28 (45)                                                                                                                                                                                      | v           |             |           |
| D 13                                                                   | -> 6780.089 9 A                                           | -> dal/from 05.04.1988-> CT 1805->                                                                                                                                                                                                                         | 1           | 1           |           |
| D 14+                                                                  | -> 3240.018 9 A                                           | dado/nut                                                                                                                                                                                                                                                   | 1           | 1           |           |
| D 15+                                                                  | 3240.008 9                                                | dado/nut                                                                                                                                                                                                                                                   | 1           | 1           |           |
| D 16+                                                                  | 1760.041 9                                                | bullone/bolt M 6 X 1 X 40                                                                                                                                                                                                                                  | 1           | 1           |           |
| D 17+                                                                  | 3240.008 9                                                | dado/nut                                                                                                                                                                                                                                                   | 1           | 1           |           |
| D 18                                                                   | 1760.041 9                                                | bullone/bolt M 6 X 1 X 40                                                                                                                                                                                                                                  | 1           | 1           |           |
| D 19                                                                   | 4670.058 9                                                | guarnizione/copper gasket                                                                                                                                                                                                                                  | 1           | 1           |           |
| D 20                                                                   | 6000.021 9                                                | pastiglia/nut                                                                                                                                                                                                                                              | 2           | 2           |           |
| D 21+                                                                  | 9790.023 9                                                | vite/screw M 5 X 7                                                                                                                                                                                                                                         | 2           | 2           |           |
| D 22+                                                                  | 5200.108 560                                              | leva/lever                                                                                                                                                                                                                                                 | 1           | 1           |           |
| D 23+                                                                  | 3240.164 9                                                | dado/nut                                                                                                                                                                                                                                                   | 1           | 1           |           |
| D 24                                                                   | 5200.323 560                                              | leva com.regol.dist./control lever                                                                                                                                                                                                                         | 1           | 1           |           |
| D 25                                                                   | 1200.016 9                                                | anello OR 137/rubber oil seal                                                                                                                                                                                                                              | 1           | 1           |           |
| D 26                                                                   | 9730.012 9                                                | vite/screw M 6 X 1 X 20                                                                                                                                                                                                                                    | 4           | 4           |           |
| D 27                                                                   | 5725.032 500                                              | molla/spring                                                                                                                                                                                                                                               | 1           | 1           |           |
| D 28                                                                   | 4670.088 9                                                | guarnizione/copper gasket 18X24X1                                                                                                                                                                                                                          | 1           | 1           |           |
| D 28                                                                   | 2175.044 560                                              | cartuccia olio/oil filter element                                                                                                                                                                                                                          | 1           | 1           |           |
| Motore/Engine 12LD 435-2                                               |                                                           |                                                                                                                                                                                                                                                            |             |             |           |
| " " 12LD 475-2                                                         |                                                           |                                                                                                                                                                                                                                                            |             |             |           |

| 12LD 435-2 - 12LD 475-2<br>vedi Tavola Ric./see Parts Table 1.5302.508 |                       | 12LD 435-2                            | 12LD 475-2 |
|------------------------------------------------------------------------|-----------------------|---------------------------------------|------------|
| Pos.                                                                   | Matricola/Part No.    | Note/Remarks                          |            |
| D 29                                                                   | 9455.074 435          | tubo lubr./lub.pipe                   | 2 2        |
| D 30                                                                   | 1400.037 276          | asta liv.prolung./dipstick(mm 330)    | 1 1        |
| D 31                                                                   | 1400.077 7200         | asta livello/dipstick std (mm 210)    | 1 1        |
| ,,                                                                     | 1400.133 560          | asta livello/dipstick (mm 267)        | 1 1        |
| D 32                                                                   | ex .....              | -> da/from s.No.2809667-> CT 1804->   | v v        |
|                                                                        | -> 7555.004 9 A       | rondella/washer                       | 1 1        |
| D 33                                                                   | ex .....              | -> da/from s.No.2809667-> CT 1804->   | v v        |
|                                                                        | -> 6040.015 560 A     | perno/pin                             | 1 1        |
| D 36                                                                   | 1400.191 560          | asta liv.prolung./dipstick(mm 210)    | 1 1        |
| D 38                                                                   | ex .....              | -> dal/from 05.04.1988-> CT 1805->    | v v        |
|                                                                        | -> 5168.052 560 A     | lamierino/tabwasher                   | 1 1        |
| D 39                                                                   | ex .....              | -> dal/from 05.04.1988-> CT 1805->    | v v        |
|                                                                        | -> 3240.131 560 A     | dado/nut                              | 1 1        |
| D 40+                                                                  | 3240.058 9            | dado/nut                              | 1 1        |
| D 42                                                                   | ex 4776.083 - - - - - | sostituito da/superseded by - - ->    | v v        |
|                                                                        | -> 4775.526 560 I     | guarnizione/gasket                    | 1 1        |
| D 43                                                                   | 9730.018 9            | vite/screw M 6 X 1 X 45               | 1 1        |
| D 44                                                                   | 9765.122 9 B          | -> fino/until 04.1988 -> CT 1805      | v v        |
| D 45                                                                   | 3240.008 9 B          | -> fino/until 04.1988 -> CT 1805      | v v        |
| D 46                                                                   | 1770.042 9            | bullone/bolt M 8 X 1,25 X 10          | 1 1        |
| D 47+                                                                  | 5200.108 560          | leva/lever                            | 1 1        |
| D 48+                                                                  | 3240.164 9            | dado/nut                              | 1 1        |
| D 49+                                                                  | 5200.108 560          | leva/lever                            | 1 1        |
| D 50+                                                                  | ex 3203.047 - - - - - | sostituito da/superseded by - - ->    | v v        |
|                                                                        | -> 3240.164 9 I       | dado/nut                              | 1 1        |
| D 51+                                                                  | 2136.026 5600         | cappellotto/cap                       | 1 1        |
| D 52+                                                                  | ex 3203.047 - - - - - | sostituito da/superseded by - - ->    | v v        |
|                                                                        | -> 3240.164 9 I       | dado/nut                              | 1 1        |
| D 53+                                                                  | 1240.077 9            | anello seeqer/snap ring               | 1 1        |
| D 54+                                                                  | 7625.098 9            | rondella/washer                       | 1 1        |
| D 55+                                                                  | 6545.009 904          | pomello/knob                          | 1 1        |
| D 56+                                                                  | 4340.067 904          | guaina/jacket                         | 1 1        |
| D 57                                                                   | 7330.066 2760         | raccordo/head filter oil conn.        | 1 1        |
| D 58                                                                   | 2175.040 904          | cartuccia olio/oil filter elem.       | 1 1        |
| D 59                                                                   | 2605.019 560          | coperchio filtro/oil filter cover     | 1 1        |
| ,,                                                                     | 3902.052 5600         | flangia/ext.oil filt.flange           | 1 1        |
| D 60                                                                   | 4501.022 560          | guarnizione/gasket                    | 1 1        |
| D 61                                                                   | 3240.036 9            | dado/nut                              | 1 1        |
| D 62                                                                   | 7565.011 9            | rondella/washer                       | 1 1        |
| D 63                                                                   | 4936.009 560          | ingranaggio/gearwheel                 | 1 1        |
| D 64                                                                   | 6605.037 560          | pompa olio/lub.oil pump               | 1 1        |
| D 65                                                                   | 2200.001 9 B          | -> fino a/until 2984959 -> CT 1809    | v v        |
| D 66                                                                   | 9330.025 401          | tubo asta liv.(collett.std)/pipe      | 1 1        |
| ,,                                                                     | 9330.046 360          | tubo asta liv.(collett.2 ingr.)/p     | 1 1        |
| D 67+                                                                  | 7625.012 9            | rondella/washer                       | 1 1        |
| D 68+                                                                  | 9732.074 9            | vite/screw M 8 X 1,25 X 20            | 1 1        |
| D 69+                                                                  | ex 1240.001 9 * B     | -> da/from s.No.3090703-> CT 120001-> | v v        |
|                                                                        | -> 1165.010 9 A       | anello secur./circlip                 | 1 1        |
| D 70+                                                                  | 3240.008 9            | dado/nut                              | 1 1        |
| D 71+                                                                  | ex .....              | -> da/from s.No.2809667-> CT 1804->   | v v        |
|                                                                        | -> 7555.004 9 A       | rondella/washer                       | 1 1        |

\* (ancora valido per gruppi elettrogeni e motocompressori- escluso versioni Wacker e Kaeser/still supplied on generating sets and compressors-Wacker and Kaeser versions excluded)

Motore/Engine 12LD 435-2  
 ,, ,, 12LD 475-2

| 12LD 435-2 - 12LD 475-2<br>vedi Tavola Ric./see Parts Table 1.5302.508                                                                                                                        |                        |                                                                                                                                          |   | 12LD435-2 | 12LD475-2 |
|-----------------------------------------------------------------------------------------------------------------------------------------------------------------------------------------------|------------------------|------------------------------------------------------------------------------------------------------------------------------------------|---|-----------|-----------|
| Pos.                                                                                                                                                                                          | Matricola/Part No.     | Note/Remarks                                                                                                                             |   |           |           |
| D 72                                                                                                                                                                                          | ex 5200.265 560 * B    | -> da/from s.No.3090703-> CT 120001-><br>(Pos. 67-68-69-70-71-72-73-87-98-<br>100-101-105-106-111)                                       | v | v         |           |
|                                                                                                                                                                                               | ->=5200.605 560 A      | LEVA COMPL./LEVER ASS.Y(rpm > 3001                                                                                                       | 1 | 1         |           |
|                                                                                                                                                                                               | ex .....               | -> da/from s.No.3660013-> CT 120014->                                                                                                    | v | v         |           |
|                                                                                                                                                                                               | ->=5200.909 560 A      | LEVA COMPL./LEVER ASS.Y(rpm < 3000<br>(Pos. 67-68-70-71-72-73-85-98-100-<br>101-102-104-105-106-108-115-<br>127-128-129-130-131-132-133) | 1 | 1         |           |
| D 72+                                                                                                                                                                                         | 5200.200 560           | leva/lever                                                                                                                               | 1 | 1         |           |
| D 73+                                                                                                                                                                                         | 6140.100 560           | perno/pin                                                                                                                                | 1 | 1         |           |
| D 74                                                                                                                                                                                          | ex 2516.060 560 * B    | -> da/from s.No.3090703-> CT 120001-><br>(Pos.14-15-16-17-49-50-51-52-53-<br>54-55-56-74-76-78-80-81-82-<br>83-84-89)                    | v | v         |           |
|                                                                                                                                                                                               | ->=2690.287 560 A      | COMANDO ACCEL.A MANO/HAND CONTROL<br>(Pos.14-15-16-17-49-50-51-52-53-<br>54-55-56-74-81-82-107-109-<br>112-116-117-118)                  | 1 | 1         |           |
|                                                                                                                                                                                               | =2516.174 560          | speciale/special WACKER<br>senza leva acc./without acc.lever<br>(Pos.14-15-16-17-49-50-51-52-53-<br>74-76-78-80)                         |   | 1         |           |
|                                                                                                                                                                                               | =2516.176 560          | speciale/special KAESER<br>senza leva acc./without acc.lever<br>(Pos.14-15-16-17-49-50-51-52-53-<br>74-107-116-117)                      | 1 |           |           |
|                                                                                                                                                                                               | =2516.159 560          | speciale/special BOTTARINI<br>(Pos.14-15-16-17-49-50-51-52-53-<br>74-107-109-112-116-117-118-<br>137)                                    | 1 |           |           |
| D 75+                                                                                                                                                                                         | 5271.055 560           | leva com.stop con el.magenta/lever                                                                                                       |   | 1         |           |
| D 76+                                                                                                                                                                                         | ex 5200.194 560 * B    | -> da/from s.No.3090703-> CT 120001->                                                                                                    | v | v         |           |
|                                                                                                                                                                                               | -> vedi/see Pos. D 116 |                                                                                                                                          |   |           |           |
| D 77                                                                                                                                                                                          | 8460.055 276           | spina/taper pin                                                                                                                          | 2 | 2         |           |
| D 78+                                                                                                                                                                                         | 1200.034 9             | anello OR 105/rubber oil seal                                                                                                            | 1 | 1         |           |
| D 79                                                                                                                                                                                          | 9732.078 9             | vite/screw M 6 X 1 X 25                                                                                                                  | 5 | 5         |           |
| D 80+                                                                                                                                                                                         | 5680.077 560           | molla/spring                                                                                                                             | 1 | 1         |           |
| D 81+                                                                                                                                                                                         | 6870.021 904           | prigioniero/stud                                                                                                                         | 1 | 1         |           |
| D 82+                                                                                                                                                                                         | 5200.110 560           | leva/lever                                                                                                                               | 1 | 1         |           |
| D 83+                                                                                                                                                                                         | 1200.034 9             | anello OR 105/rubber oil seal                                                                                                            | 1 | 1         |           |
| D 84+                                                                                                                                                                                         | 5680.077 560           | molla/spring                                                                                                                             | 1 | 1         |           |
| D 85+                                                                                                                                                                                         | 1241.009 9             | anello coegee/snap ring                                                                                                                  | 2 | 2         |           |
| D 86                                                                                                                                                                                          | 5655.046 904           | molla regol./gov.spring (WACKER)                                                                                                         |   | 1         |           |
|                                                                                                                                                                                               | ex 5655.076 560 * B    | -> da/from s.No.3090703-> CT 120001->                                                                                                    | v | v         |           |
|                                                                                                                                                                                               | -> vedi/see Pos. D 113 |                                                                                                                                          |   |           |           |
|                                                                                                                                                                                               | 5655.077 560           | molla regol./gov.spring(rpm < 2200                                                                                                       |   | 1         |           |
| D 87+                                                                                                                                                                                         | ex 5200.271 - (npd)    | -> da/from s.No.3090703-> CT 120001->                                                                                                    | v | v         |           |
|                                                                                                                                                                                               | -> vedi/see Pos. D 127 |                                                                                                                                          |   |           |           |
| D 88                                                                                                                                                                                          | ex 9732.063 9 * B      | -> da/from s.No.3090703-> CT 120001->                                                                                                    | v | v         |           |
|                                                                                                                                                                                               | -> vedi/see Pos. D 114 |                                                                                                                                          |   |           |           |
| D 89+                                                                                                                                                                                         | 5200.154 560           | leva/lever                                                                                                                               | 1 | 1         |           |
| * (ancora valido per gruppi elettrogeni e motocompressori-<br>escluso versioni Wacker e Kaeser/still supplied on ge-<br>nerating sets and compressors-Wacker and Kaeser versions<br>excluded) |                        |                                                                                                                                          |   |           |           |
| Motore/Engine 12LD 435-2                                                                                                                                                                      |                        |                                                                                                                                          |   |           |           |
| " " 12LD 475-2                                                                                                                                                                                |                        |                                                                                                                                          |   |           |           |
| TOMBARDINI MOTORI F.I.M. S.p.a. Edizione del/Issue of 04.1999                                                                                                                                 |                        |                                                                                                                                          |   |           |           |



|  <b>12LD 435-2 - 12LD 475-2</b><br>vedi Tavola Ric./see Parts Table 1.5302.508                               |                        |      |                                           |    |    |  |
|-----------------------------------------------------------------------------------------------------------------------------------------------------------------------------------------------|------------------------|------|-------------------------------------------|----|----|--|
| Pos.                                                                                                                                                                                          | Matricola/Part No.     |      | Note/Remarks                              |    |    |  |
| D 90                                                                                                                                                                                          | 1770.009               | 9    | bullone/bolt M 8 X 1,25 X 35              | 2  | 2  |  |
| D 91                                                                                                                                                                                          | 7565.007               | 9    | rondella/washer                           | 2  | 2  |  |
| D 93                                                                                                                                                                                          | 1200.001               | 9    | anello OR 108/O ring                      | 1  | 1  |  |
| D 95+                                                                                                                                                                                         | 5090.010               | 560  | lamiera/filter panel                      | 1  | 1  |  |
| D 96+                                                                                                                                                                                         | 7565.004               | 9    | rondella/washer                           | 1  | 1  |  |
| D 97                                                                                                                                                                                          | 1400.095               | 360  | asta livello/dipstick (mm 441)            | 1  | 1  |  |
| D 98+                                                                                                                                                                                         | ex .....               |      | -> da/from s.No.3090703-> CT 120001->     | v  | v  |  |
|                                                                                                                                                                                               | -> 7625.106            | 9    | A rondella/washer                         | 2  | 2  |  |
| D 99+                                                                                                                                                                                         | 1760.001               | 9    | bullone/bolt M 6 X 1 X 10                 | 1  | 1  |  |
| D100+                                                                                                                                                                                         | ex 6140.101            | 560  | * B -> da/from s.No.3090703-> CT 120001-> | v  | v  |  |
|                                                                                                                                                                                               | -> 6140.370            | 560  | A perno/pin                               | 1  | 1  |  |
| D101+                                                                                                                                                                                         | ex 5200.250            | 395  | * B -> da/from s.No.3090703-> CT 120001-> | v  | v  |  |
|                                                                                                                                                                                               | -> 5200.587            | 560  | A leva/lever                              | 1  | 1  |  |
| D102+                                                                                                                                                                                         | ex 7625.103            | 9    | * B -> da/from s.No.3090703-> CT 120001-> | v  | v  |  |
|                                                                                                                                                                                               | ex 7625.104            | 9    | * B -> da/from s.No.3090703-> CT 120001-> | v  | v  |  |
|                                                                                                                                                                                               | -> 3527.246            | 560  | A distanziale/spacer                      | 1  | 1  |  |
| D103                                                                                                                                                                                          | ex 5801.088            | 560  | * B -> da/from s.No.2809667-> CT 1804->   | v  | v  |  |
|                                                                                                                                                                                               | -> 5550.026            | 3600 | A molla suppl./extra f.spr.(rpm>3001      | 1  | 1  |  |
|                                                                                                                                                                                               | ex .....               |      | -> da/from s.No.3660013-> CT 120014->     | v  | v  |  |
|                                                                                                                                                                                               | -> 5801.154            | 360  | A molla suppl./extra f.spr.(rpm<3000      | 1  | 1  |  |
|                                                                                                                                                                                               | 5801.159               | 560  | molla suppl./extra f.spr.(mtcompr.        | 1  | 1  |  |
| D104+                                                                                                                                                                                         | 1241.009               | 9    | anello seeger/snap ring                   | 1  | 1  |  |
| D105+                                                                                                                                                                                         | 3000.004               | 9    | cuscinetto/ball bearing                   | 2  | 2  |  |
| D106+                                                                                                                                                                                         | 3000.004               | 9    | cuscinetto/ball bearing                   | 1  | 1  |  |
| D107+                                                                                                                                                                                         | 1200.034               | 9    | anello OR/rubber oil seal                 | 1  | 1  |  |
| D108+                                                                                                                                                                                         | 1241.009               | 9    | anello seeger/snap ring                   | 1  | 1  |  |
| D109+                                                                                                                                                                                         | 1200.034               | 9    | anello OR/rubber oil seal                 | 1  | 1  |  |
| D110                                                                                                                                                                                          | ex 3521.038            | 560  | * B -> fino a/until 3090703-> CT 120001   | v  | v  |  |
| D111+                                                                                                                                                                                         | ex 8785.070            | 395  | * B -> da/from s.No.3090703-> CT 120001-> | v  | v  |  |
|                                                                                                                                                                                               | -> vedi/see Pos. D 128 |      |                                           |    |    |  |
| D112+                                                                                                                                                                                         | 5680.077               | 560  | molla/spring                              | 1  | 1  |  |
| D113+                                                                                                                                                                                         | ex .....               |      | -> da/from s.No.3090703-> CT 120001->     | v  | v  |  |
|                                                                                                                                                                                               | -> 9245.135            | 560  | A tirante/tie rod                         | 1  | 1  |  |
| D114+                                                                                                                                                                                         | ex .....               |      | -> da/from s.No.3090703-> CT 120001->     | v  | v  |  |
|                                                                                                                                                                                               | -> 9730.024            | 9    | A vite/screw M 8 X 1,25 X 16              | 2  | 2  |  |
| D115+                                                                                                                                                                                         | ex .....               |      | -> da/from s.No.3090703-> CT 120001->     | v  | v  |  |
|                                                                                                                                                                                               | -> 6370.281            | 560  | A piastra/plate                           | 1  | 1  |  |
| D116+                                                                                                                                                                                         | ex .....               |      | -> da/from s.No.3090703-> CT 120001->     | v  | v  |  |
|                                                                                                                                                                                               | -> 5200.583            | 560  | A leva/lever                              | 1  | 1  |  |
| D117+                                                                                                                                                                                         | 5680.077               | 560  | molla/spring                              | 1  | 1  |  |
|                                                                                                                                                                                               | 5680.078               | 560  | per com.stop con el.magn. o Wacker        | 1  | 1  |  |
| D118+                                                                                                                                                                                         | 5200.154               | 560  | leva/lever                                | 1  | 1  |  |
| D119                                                                                                                                                                                          | 8430.065               | 9    | spina/locking needle                      | 1  | 1  |  |
| D120                                                                                                                                                                                          | ex 7555.029            | 9    | B -> fino a/until 3528961-> CT 120006     | v  | v  |  |
| D121                                                                                                                                                                                          | ex 1770.039            | 9    | B -> da/from s.No.3528962-> CT 120006->   | v  | v  |  |
|                                                                                                                                                                                               | -> 1770.155            | 9    | A bullone/bolt M 8 X 1,25 X 30            | 14 | 14 |  |
| D122+                                                                                                                                                                                         | 9765.108               | 9    | vite/screw                                | 1  | 1  |  |
| * (ancora valido per gruppi elettrogeni e motocompressori-<br>escluso versioni Wacker e Kaeser/still supplied on ge-<br>nerating sets and compressors-Wacker and Kaeser versions<br>excluded) |                        |      |                                           |    |    |  |
| Motore/Engine 12LD 435-2                                                                                                                                                                      |                        |      |                                           |    |    |  |
| " " 12LD 475-2                                                                                                                                                                                |                        |      |                                           |    |    |  |

| 12LD 435-2 - 12LD 475-2<br>vedi Tavola Ric./see Parts Table 1.5302.508 |                       |                                       |  | 12LD435-2 | 12LD475-2 |
|------------------------------------------------------------------------|-----------------------|---------------------------------------|--|-----------|-----------|
| Pos.                                                                   | Matricola/Part No.    | Note/Remarks                          |  |           |           |
| D123                                                                   | ex 6647.051 - - - - - | sostituito da/superseded by - - ->    |  | v         | v         |
|                                                                        | -> 6645.466 360 I     | PORTINA DI FONDO/OIL PAN              |  | 1         | 1         |
|                                                                        | =6645.464 360         | PORTINA FONDO (scarico l.mot.avv.)    |  | 1         | 1         |
|                                                                        | =6645.469 360         | OIL PAN (start.mot.side disch.oil)    |  | 1         | 1         |
|                                                                        | =6645.466 435         | PORTINA FONDO (scarico in basso)      |  | 1         | 1         |
|                                                                        | =6645.470 360         | OIL PAN (downward discharging oil)    |  | 1         | 1         |
|                                                                        | =6645.460 360         | PORTINA FONDO/OIL PAN (Kaeser Vers)   |  | 1         | 1         |
|                                                                        | =6645.482 435         | PORTINA FONDO (scarico l.presa m.)    |  | 1         | 1         |
|                                                                        |                       | OIL PAN (PTO side discharging oil)    |  | 1         | 1         |
|                                                                        |                       | PORTINA FONDO media capac.(4,5 l.)    |  | 1         | 1         |
|                                                                        |                       | OIL PAN (medium capacity)             |  | 1         | 1         |
|                                                                        |                       | PORTINA FONDO alta capac. (7,5 l.)    |  | 1         | 1         |
|                                                                        |                       | OIL PAN (high capacity)               |  | 1         | 1         |
|                                                                        |                       | (Pos. 95-96-99-122-123-124-125)       |  |           |           |
| D124+                                                                  | 4670.016 9            | guarnizione/copper gasket             |  | 1         | 1         |
| D125+                                                                  | 8965.005 9            | tappo/oil drain plug                  |  | 1         | 1         |
| D126                                                                   | 4601.042 360          | guarnizione/gasket                    |  | 1         | 1         |
| D127+                                                                  | ex .....              | -> da/from s.No.3090703-> CT 120001-> |  |           |           |
|                                                                        | -> 5200.585 560 A     | leva/lever                            |  | 1         | 1         |
| D128+                                                                  | ex .....              | -> da/from s.No.3090703-> CT 120001-> |  |           |           |
|                                                                        | -> 8785.103 560 A     | supporto/support                      |  | 1         | 1         |
| D129+                                                                  | ex .....              | -> da/from s.No.3090703-> CT 120001-> |  | v         | v         |
|                                                                        | -> 5655.107 560 A     | molla regol./gov.spring(rpm > 3001)   |  | 1         | 1         |
|                                                                        | ex .....              | -> da/from s.No.3660013-> CT 120014-> |  | v         | v         |
|                                                                        | -> 5655.242 435 A     | molla regol./gov.spring(rpm < 3000)   |  | 1         | 1         |
| D130+                                                                  | ex .....              | -> da/from s.No.3090703-> CT 120001-> |  | v         | v         |
|                                                                        | -> 1541.106 560 A     | bilanciere/balance lever              |  | 1         | 1         |
| D131+                                                                  | ex .....              | -> da/from s.No.3090703-> CT 120001-> |  | v         | v         |
|                                                                        | -> 5655.107 560 A     | molla regol./gov.spring(rpm > 3001)   |  | 1         | 1         |
|                                                                        | ex .....              | -> da/from s.No.3660013-> CT 120014-> |  | v         | v         |
|                                                                        | -> 5655.242 435 A     | molla regol./gov.spring(rpm < 3000)   |  | 1         | 1         |
| D132+                                                                  | ex .....              | -> da/from s.No.3090703-> CT 120001-> |  | v         | v         |
|                                                                        | -> 1165.010 9 A       | anello/circlip                        |  | 1         | 1         |
| D133+                                                                  | ex .....              | -> da/from s.No.3090703-> CT 120001-> |  | v         | v         |
|                                                                        | -> 7625.010 9 A       | rondella/washer                       |  | 1         | 1         |
| D134                                                                   | 1200.002 9            | anello OR 117 per prolunga/O ring     |  | 1         | 1         |
| D135                                                                   | 6902.155              | prolunga scar.olio/disch.oil ext.     |  | 1         | 1         |
| D136                                                                   | 5151.075 560          | lamierino/plate                       |  | 1         | 1         |
| D137+                                                                  | .....                 | vedi/see Pos. D 74 (2516.159)         |  |           |           |
| D138                                                                   | 8900.167 560          | supporto elettromagnete/support       |  | 1         | 1         |
| D139                                                                   | 3240.008 9            | dado/nut M 6                          |  | 1         | 1         |
| D140                                                                   | 7200.093 560          | puntalino/drive rod                   |  | 1         | 1         |
| D141                                                                   | 3527.071 276          | distanziale/spacer                    |  | 1         | 1         |
| D142                                                                   | 3586.041 824          | elettromagnete per stop/el.magnet     |  | 1         | 1         |
| E 1                                                                    | ex 9571.077 - - - - - | sostituito da/superseded by - - ->    |  | v         | v         |
|                                                                        | -> 9571.087 5600 I    | tubo spurgo/bleeding pipe (mm 745)    |  | 1         | 1         |
|                                                                        | 9571.085 560          | tubo spurgo/bleeding pipe (mm 1150)   |  | 1         | 1         |
|                                                                        | 9571.069 560          | tubo spurgo/bleeding pipe (mm 1350)   |  | 1         | 1         |
|                                                                        | 9571.152 560          | tubo spurgo/bleeding pipe (mm 1550)   |  | 1         | 1         |
|                                                                        | 9571.095 360          | tubo spurgo/bleeding pipe (mm 2550)   |  | 1         | 1         |
| E 2                                                                    | 4670.058 9            | guarnizione/copper gasket             |  | 1         | 1         |
| E 3                                                                    | 1901.029 9            | bullone raccordo/connection bolt      |  | 1         | 1         |
| E 4                                                                    | 4670.058 9            | guarnizione/copper gasket             |  | 1         | 1         |
| E 5                                                                    | 1901.029 9            | bullone raccordo/connection bolt      |  | 1         | 1         |
| E 6                                                                    | 3616.082 904          | fascetta serbatoio/tank clamp         |  | 2         | 2         |
| E 7                                                                    | 9043.015 276          | tappo serbatoio/fuel tank cap         |  | 1         | 1         |
| Motore/Engine 12LD 435-2                                               |                       |                                       |  |           |           |
| " " 12LD 475-2                                                         |                       |                                       |  |           |           |



**12LD 435-2 - 12LD 475-2**  
**vedi Tavola Ric./see Parts Table 1.5302.508**

| Pos.                           | Matricola/Part No.    | Note/Remarks                                            | 12LD435-2 | 12LD475-2 |
|--------------------------------|-----------------------|---------------------------------------------------------|-----------|-----------|
| E 8+                           | 9043.025 530          | tappo serbatoio/tank cap                                | 1         | 1         |
| E 9+                           | 9761.001 9            | vite/screw M 4                                          | 5         | 6         |
| E 10+                          | 4776.040 276          | guarnizione/gasket                                      | 1         | 1         |
| E 11+                          | 5055.023 276          | lamiera chiusura/plate                                  | 1         | 1         |
| E 12                           | 4906.008 720          | indicatore livello/fuel gauge                           | 1         | 1         |
| E 13                           | ex 3790.042 - - - - - | sostituito da/superseded by - - ->                      | v         | v         |
|                                | -> 3790.074 500 I     | flangia/flange                                          | 2         | 2         |
| E 14                           | 3203.050 9            | dado/nut                                                | 4         | 4         |
| E 15                           | 7565.004 9            | rondella/washer                                         | 2         | 2         |
| E 16+                          | 6760.045 9            | prigioniero/stud M 6 X 65 (80)                          | 4         | 4         |
| F 17                           | 9375.279 435          | tubo alta press./high press.pipe                        | 1         | 1         |
| E 18                           | 4670.058 9            | guarnizione/copper gasket                               | 1         | 1         |
| E 19                           | 4670.058 9            | guarnizione/copper gasket                               | 1         | 1         |
| E 20                           | 1755.002 9            | bullone/bolt M 5 X 0,8 X 12                             | 2         | 2         |
| E 21                           | 3616.018 276          | fascetta/strip fixing                                   | 2         | 2         |
| E 22                           | 5400.046 276          | manicotto/rubber sheathing                              | 2         | 2         |
| E 23                           | 9730.139 9            | vite/screw M 6 X 1 X 60                                 | 2         | 2         |
| E 24                           | 1557.020 45           | blocchetto/nut                                          | 2         | 2         |
| E 25                           | 1557.019 45           | blocchetto/nut                                          | 2         | 2         |
| E 26                           | ex-8103.046 - - - - - | sostituite da/superseded by - - ->                      | v         | v         |
|                                | -> 8103.041 360 I     | serbatoio/f.tank 10 lt 370x170x140                      | 1         | 1         |
|                                | 8102.038 904          | serbatoio/f.tank 10 lt 410x190x140                      | 1         | 1         |
| E 27                           | =8103.021 904         | SERBATOIO/FUEL TANK 15 lt/liters<br>(Pos. 8-9-10-11-27) | 1         | 1         |
| E 28                           | ex 8430.036 9 B       | -> fino a/until 05.1993                                 | v         | v         |
| E 29                           | =6615.042 395         | PORTAPOLVER./NOZZLE HOLDER                              | 2         | 2         |
|                                | =6615.045 395         | PORTAPOLVER./NOZZLE-HOLDER Bosch<br>(Pos. 29-30)        | 2         | 2         |
| E 30+                          | 6531.104 395          | polverizzatore/nozzle                                   | 2         | 2         |
| E 31                           | 4650.037 260          | guarnizione/gasket                                      | 2         | 2         |
| E 32                           | 4670.064 9            | guarnizione/copper gasket 1,00                          | 2         | 2         |
|                                | 4670.065 9            | guarnizione/copper gasket 1,50                          | 2         | 2         |
| E 33                           | 7301.006 500          | raccordo/connection                                     | 2         | 2         |
| F 34                           | 9375.280 435          | tubo alta press./high press.pipe                        | 1         | 1         |
| E 35                           | 3617.077 360          | fascetta/fix.tank strap (mm 592)                        | 2         | 2         |
|                                | 3616.085 904          | fascetta/fix.tank strap (mm 625)                        | 2         | 2         |
| E 36                           | 9600.057 271          | tubetto/spacer                                          | 2         | 2         |
| E 37                           | 8315.016 904          | spessore/rubber shim                                    | 1         | 1         |
| E 38                           | 8042.024 904          | sella serbatoio/supporto                                | 1         | 1         |
| E 39+                          | 3586.058 560          | elettrostop/electric valve                              | 1         | 1         |
| E 40                           | =3440.030 560         | DISPOSIT.ARRESTO QSD/STOP DEVICE<br>(Pos. 30 40 31)     | 1         | 1         |
| E 41                           | ex 3617.073 - - - - - | sostituito da/superseded by - - ->                      | v         | v         |
|                                | ex 3617.199 435 B     | -> da/from s.No.4071886-> CT 120013->                   | v         | v         |
|                                | -> 3617.211 435 A     | fascetta/fix.tank strap (mm 345)                        | 2         | 2         |
| E 42                           | 7265.008 271          | raccordo/connection                                     | 2         | 2         |
| E 43                           | 1200.031 9            | anello OR/rubber oil seal                               | 2         | 2         |
| E 44                           | 4701.006 904          | guarnizione/gasket                                      | 1         | 1         |
| E 45                           | 8866.018 904          | supporto/support                                        | 1         | 1         |
| E 46                           | 7470.003 271          | riempitore/filler                                       | 2         | 2         |
| E 47                           | 8335.029 271          | spessore/shim                                           | 2         | 2         |
| E 48                           | 5755.034 271          | molla/spring                                            | 2         | 2         |
| E 49                           | =3730.036 283         | FILTRO COMBUSTIBILE/FUEL FILTER<br>(Pos. 49-82)         | 1         | 1         |
| Motore/Engine 12LD 435-2 ..... |                       |                                                         |           |           |
| ,, ,, 12LD 475-2 .....         |                       |                                                         |           |           |

| 12LD 435-2 - 12LD 475-2<br>vedi Tavola Ric./see Parts Table 1.5302.508 |                    |                                                                |   | 12LD435-2 | 12LD475-2 |
|------------------------------------------------------------------------|--------------------|----------------------------------------------------------------|---|-----------|-----------|
| Pos.                                                                   | Matricola/Part No. | Note/Remarks                                                   |   |           |           |
| E 50                                                                   | 9375.361 560       | tubo comb./fuel hose (mm 330)                                  | 1 | 1         |           |
| "                                                                      | 9375.357 560       | tubo comb./fuel pipe (mm 630)                                  | 1 | 1         |           |
| "                                                                      | 9375.368 360       | tubo comb./fuel hose (mm 800)                                  | 1 | 1         |           |
| "                                                                      | 9375.362 560       | tubo comb./fuel hose (mm 1030)                                 | 1 | 1         |           |
| "                                                                      | 9375.363 560       | tubo comb./fuel hose (mm 2030)                                 | 1 | 1         |           |
| E 51                                                                   | 4760.015 271       | guarnizione/gasket                                             | 2 | 2         |           |
| E 52                                                                   | 6578.042 435       | pompante/injection plunger                                     | 2 | 2         |           |
| E 53                                                                   | 9730.100 9         | vite/screw M 8 X 1,25 X 25                                     | 3 | 3         |           |
| E 54                                                                   | 7625.010 9         | rondella/washer                                                | 4 | 4         |           |
| E 55                                                                   | 9672.012 500       | valvolina/delivery valve                                       | 2 | 2         |           |
| E 56+                                                                  | 8400.048 9         | spina/taper pin                                                | 1 | 1         |           |
| E 57                                                                   | 1901.031 9         | bullone raccordo/connection bolt                               | 1 | 1         |           |
| E 58                                                                   | 1901.101 625       | bullone raccordo/union bolt l=60                               | 1 | 1         |           |
| "                                                                      | 1901.102 560       | bullone/bolt(Wacker version) l=43                              | 1 | 1         |           |
| E 59                                                                   | 3730.071 276       | filtrino combustibile/fuel filter                              | 1 |           |           |
| E 60                                                                   | 1901.033 9         | bullone raccordo/union bolt M 6                                | 1 | 1         |           |
| E 61                                                                   | 4775.196 9         | guarnizione/gasket                                             | 1 | 1         |           |
| E 62                                                                   | 9080.037 9         | tappo/deaeration plug                                          | 1 | 1         |           |
| F 63                                                                   | 4670.060 9         | guarnizione/copper gasket                                      | 2 | 2         |           |
| E 64                                                                   | 4670.060 9         | guarnizione/copper gasket d.12                                 | 2 | 2         |           |
| E 65                                                                   | 9730.139 9         | vite/screw M 6 X 1 X 60                                        | 2 | 2         |           |
| E 66                                                                   | 9080.037 9         | tappo/deaeration plug                                          | 1 | 1         |           |
| E 67                                                                   | 4775.196 9         | guarnizione/gasket                                             | 1 | 1         |           |
| E 68+                                                                  | 5575.006 273       | molla/spring                                                   | 1 | 1         |           |
| E 69+                                                                  | 3930.019 273       | fondello/tray                                                  | 1 | 1         |           |
| E 70+                                                                  | 1200.268 9         | anello OR/rubber oil seal                                      | 1 | 1         |           |
| F 71                                                                   | =3730.015 273      | FILTRO COMB./FUEL FILTER<br>(Pos. 68-69-70-71-72-73-98-99-100) | 1 | 1         |           |
| E 71+                                                                  | 2175.009 273       | cartuccia comb./f.filter element                               | 1 | 1         |           |
| E 72+                                                                  | 4490.017 273       | guarnizione/gasket                                             | 1 | 1         |           |
| E 73+                                                                  | 4430.071 260       | guarnizione/gasket                                             | 1 | 1         |           |
| E 74                                                                   | 6370.515 560       | piastra supporto/supporto                                      | 1 | 1         |           |
| E 75                                                                   | 8636.001 904       | supporto antivibr./vibr.isolator                               | 4 | 4         |           |
| E 76                                                                   | 9043.015 276       | tappo serbatoio/tank cap                                       | 1 |           |           |
| F 77                                                                   | 8866.067 276       | supporto/support                                               | 2 |           |           |
| E 78                                                                   | 4701.029 276       | spessore/shim                                                  | 2 |           |           |
| E 79                                                                   | 9245.076 276       | tirante/tie rod                                                | 4 |           |           |
| E 80                                                                   | 8760.038 560       | supporto filtro/filter support                                 | 1 | 1         |           |
| E 81+                                                                  | 2175.045 283       | cartuccia comb./f.filter element                               | 1 | 1         |           |
| E 82+                                                                  | 2175.045 283       | cartuccia combust./fuel cartridge                              | 1 | 1         |           |
| E 83                                                                   | =3730.068 104      | FILTRO COMBUSTIBILE/FUEL FILTER<br>(Pos. 83-124)               | 1 |           |           |
| E 84                                                                   | 6590.076 435       | pompa iniezione/injection pump                                 | 1 | 1         |           |
| E 85                                                                   | 6230.075 277       | piastrina/safety plate                                         | 2 | 2         |           |
| E 86                                                                   | 4580.002 276       | guarnizione/gasket 0,10                                        | 1 | 1         |           |
| "                                                                      | 4580.009 276       | guarnizione/gasket 0,50                                        | 1 | 1         |           |
| "                                                                      | 4580.068 672       | guarnizione/gasket 0,05                                        | 1 | 1         |           |
| E 87                                                                   | 1580.023 276       | boccola/bushing                                                | 1 | 1         |           |
| E 88                                                                   | 7626.017 9         | rondella/washer                                                | 1 | 1         |           |
| E 89                                                                   | 9375.351 560       | tubo comb./fuel pipe (mm 190)                                  | 1 | 1         |           |
| E 90                                                                   | 2900.903 9         | copiglia/cotter pin                                            | 1 | 1         |           |
| E 91                                                                   | 7270.104 9         | raccordo/banjo union d.10                                      | 1 | 1         |           |
| E 92                                                                   | 3587.103 560       | el.valvola su pm.iniez./el.valve                               | 1 | 1         |           |
| E 93                                                                   | 1901.040 9         | bullone/connect.bolt M 12                                      | 1 | 1         |           |
| E 94                                                                   | 4670.060 9         | guarniz.rame/copper gasket d.12                                | 2 | 2         |           |
| E 95                                                                   | 9375.627 435       | pm.al.->el.valv.pm.ini./fuel hose                              | 1 | 1         |           |
| E 96                                                                   | 9571.207 435       | tubo spurgo/bleeding pipe (KAESER)                             | 1 |           |           |
| Motore/Engine 12LD 435-2                                               |                    |                                                                |   |           |           |
| "                                                                      | "                  | 12LD 475-2                                                     |   |           |           |



**12LD 435-2 - 12LD 475-2**  
**vedi Tavola Ric./see Parts Table 1.5302.508**

| Pos.                            | Matricola/Part No.      | Note/Remarks                                      | 12LD435-2 | 12LD475-2 |
|---------------------------------|-------------------------|---------------------------------------------------|-----------|-----------|
| E 98+                           | 2605.033 273            | coperchio/filter cover                            | 1         | 1         |
| E 99+                           | 1202.052 9              | anello OR/rubber oil seal                         | 1         | 1         |
| E100+                           | 1760.076 9              | bullone/bolt                                      | 1         | 1         |
| E101                            | 3630.008 9              | fascetta/clamp                                    | 1         | 1         |
| E102                            | 1901.032 9              | bullone raccordo/union bolt M 14                  | 1         | 1         |
| E103                            | 4670.061 9              | guarniz. rame/copper gasket d.14                  | 2         | 2         |
| E104                            | 4850.009 260            | guida/guide                                       | 1         | 1         |
| E105                            | 7980.020 260            | scodellino/cup                                    | 2         | 2         |
| E106                            | 1415.006 261            | asta comando/control rod                          | 1         | 1         |
| E107                            | ex 8235.014 - - (npd) - | vedi/see Pos. E 84                                | v         | v         |
| E108                            | 9865.040 261            | vite/screw                                        | 1         | 1         |
| E109                            | 1901.030 9              | bullone raccordo/connection bolt                  | 1         | 1         |
| E110                            | 7200.078 560            | puntalino/drive rod                               | 1         | 1         |
| E111                            | 4670.059 9              | guarnizione/copper gasket                         | 2         | 2         |
| E112                            | ex 1970.055 - - (npd) - | vedi/see Pos. E 84                                | v         | v         |
| E113                            | 6230.069 260            | piastra/plate                                     | 1         | 1         |
| E114                            | ex 9375.278 - - - - -   | sostituito da/superseded by - - ->                | v         | v         |
|                                 | ex 9375.240 - - - - -   | sostituito da/superseded by - - ->                | v         | v         |
|                                 | -> 9375.276 904 I       | tubo comb./fuel pipe (mm 430)                     | 1         | 1         |
|                                 | 9375.310 904            | tubo comb./fuel pipe (mm 720)                     | 1         | 1         |
|                                 | 9375.859 107            | tubo comb./fuel pipe (mm 1000)                    | 1         | 1         |
|                                 | 9375.308 904            | tubo comb./fuel pipe (mm 2000)                    | 1         | 1         |
| E115                            | 9375.276 904            | tubo comb./fuel pipe (mm 430)                     | 1         | 1         |
| E116                            | 3587.105 500            | el.valvola su motore/electrovalve                 | 1         |           |
| E117                            | 4670.059 9              | guarnizione/copper gasket d.10                    | 4         | 4         |
| E118                            | 8103.031 276            | serbatoio/fuel tank 29 lt./liters                 | 1         |           |
| E119                            | 4701.030 276            | spessore/shim                                     | 2         |           |
| E120                            | 8866.066 276            | supporto/support                                  | 2         |           |
| E121                            | 8635.059 9              | supporto antivibr./vibr.isolator                  | 4         |           |
| E122                            | =3730.039 560           | FILTRO COMBUSTIBILE/FUEL FILTER<br>(Pos. 122-123) | 1         |           |
| E123+                           | 2175.053 560            | cartuccia combust./fuel cartridge                 | 1         |           |
| E124+                           | 2175.046 276            | cartuccia combust./fuel cartridge                 |           | 1         |
| E125                            | =3730.037 276           | FILTRO COMBUSTIBILE/FUEL FILTER<br>(Pos. 125-126) | 1         |           |
| E126+                           | 2175.046 276            | cartuccia combust./fuel cartridge                 | 1         |           |
| E127                            | 5625.002 260            | molla/spring                                      | 2         | 2         |
| E128                            | 4670.061 9              | guarniz. rame/copper gasket d.14                  | 2         | 2         |
| E129                            | 1901.032 9              | bullone raccordo/union bolt M 14                  | 1         | 1         |
| E130                            | 6230.068 260            | perno/pin                                         | 2         | 2         |
| E131                            | 6400.024 260            | piattello/retainer                                | 2         | 2         |
| E132                            | 7215.017 260            | punteria/tappet                                   | 2         | 2         |
| E133                            | ex 7770.020 - - (npd) - | vedi/see Pos. E 132                               | v         | v         |
| E134                            | ex 1970.054 - - (npd) - | vedi/see Pos. E 132                               | v         | v         |
| E135                            | ex 4580.047 - - - - -   | sostituito da/superseded by - - ->                | v         | v         |
|                                 | ex 4580.169 560 B ->    | da/from s.No.3528962-> CT 120006->                | v         | v         |
|                                 | ex 4580.170 560 B       | " " " "                                           | v         | v         |
|                                 | -> vedi/see Pos. E 136  |                                                   |           |           |
| E136                            | ex .....                | -> da/from s.No.3528962-> CT 120006->             |           |           |
|                                 | -> 1200.087 9 A         | anello OR/O ring                                  | 1         | 1         |
| E137+                           | 6780.008 9              | prigioniero/stud M 8 X 20 (32)                    | 2         | 2         |
| E138                            | 9375.690 104            | tubo filtro->pm.al./hose (mm 220)                 | 1         | 1         |
|                                 | 9375.854 107            | tubo filtro->pm.al./hose (mm 650)                 | 1         |           |
|                                 | 9375.029 904            | tubo filtro->pm.al./hose (mm 800)                 | 1         | 1         |
|                                 | 9375.853 107            | tubo filtro->pm.al./hose (mm 1000)                | 1         | 1         |
|                                 | 9375.022 560            | tubo filtro->pm.al./hose (mm 2000)                | 1         | 1         |
| <b>Motore/Engine 12LD 435-2</b> |                         |                                                   |           |           |
| <b>" " 12LD 475-2</b>           |                         |                                                   |           |           |

| 12LD 435-2 - 12LD 475-2  |                    | vedi Tavola Ric./see Parts Table 1.5302.508 |                                       | 12LD435-2 | 12LD475-2 |
|--------------------------|--------------------|---------------------------------------------|---------------------------------------|-----------|-----------|
| Pos.                     | Matricola/Part No. | Note/Remarks                                |                                       |           |           |
| E139                     | ex 6585.030 276    | B                                           | -> da/from s.No.3528962-> CT 120006-> | v         | v         |
|                          | -> 6585.079 625    | A                                           | pompa alimentazione/feed pump         | 1         | 1         |
| E140                     | 1901.030 9         |                                             | bullone raccordo/connection bolt      | 1         | 1         |
| E141                     | 4670.059 9         |                                             | guarnizione/copper gasket             | 2         | 2         |
| E142                     | 3240.164 9         |                                             | dado/nut M 8                          | 2         | 2         |
| E143                     | 9375.908 435       |                                             | el.valv.->pm al.->spurgo/fuel hose    | 1         | 1         |
| E144                     | 1901.030 9         |                                             | bullone racc./connection bolt M 10    | 2         | 2         |
| E145                     | 1557.019 45        |                                             | blocchetto/nut                        | 2         | 2         |
| E146                     | 1557.020 45        |                                             | blocchetto/nut                        | 2         | 2         |
| E147                     | 3521.043 3600      |                                             | distanziale/spacer                    | 2         | 2         |
| E148                     | 6780.016 9         |                                             | prigioniero/stud M 8 X 28 (40)        | 2         | 2         |
| E149                     | 3240.018 9         |                                             | dado/nut                              | 2         | 2         |
| E150                     | 4701.068 360       |                                             | guarnizione/gasket                    | 1         | 1         |
| E151                     | 7625.012 9         |                                             | rondella/washer                       | 2         | 2         |
| E152                     | 7565.007 9         |                                             | rondella/washer                       | 2         | 2         |
| E153                     | ex 8865.156 435    | B                                           | -> da/from s.No.4071886-> CT 120013-> | v         | v         |
|                          | -> 8865.191 435    | A                                           | supporto/support                      | 1         | 1         |
| E154                     | 1770.056 9         |                                             | bullone/bolt M 8 X 1,25 X 18          | 2         | 2         |
| E155                     | 7565.007 9         |                                             | rondella/washer                       | 2         | 2         |
| E156                     | 1901.052 625       |                                             | bullone raccordo/union bolt M 8       | 1         | 1         |
| E157                     | 1901.152 625       |                                             | bullone raccordo/union bolt l=51      | 1         | 1         |
| E158                     | 8866.092 360       |                                             | supporto serbatoio/tank support       | 1         | 1         |
| E159                     | 8900.318 435       |                                             | supporto elettrovalvola/support       | 1         | 1         |
| E160                     | 5140.014 360       |                                             | lamiera/panel                         | 1         | 1         |
| E161                     | 8545.616 475       |                                             | supporto filtro/filter support        | 1         | 1         |
| E162                     | 9370.046 532       |                                             | tubo pm.al.->QSD filt. (mm 275)       | 1         | 1         |
|                          | 9375.896 550       |                                             | tubo pm.al.->QSD filt. (mm 340)       | 1         | 1         |
|                          | 9375.945 550       |                                             | tubo pm.al.->QSD filt. (mm 1000)      | 1         | 1         |
| E163                     | 9372.091 276       |                                             | tubo serb.->pm.al./f.hose(mm 314)     | 1         | 1         |
|                          | 9373.044 276       |                                             | tubo serb.->pm.al./f.hose(mm 235)     | 1         | 1         |
|                          | 9375.856 107       |                                             | tubo serb.->pm.al./f.hose(mm 1000)    | 1         | 1         |
| F 1                      | 2920.104 435       |                                             | cuffia insonorizzata/denoised hood    | 1         | 1         |
| F 6                      | ex 2615.021 9040   | B                                           | -> fino a/until 02.93 -> CT D 050     | v         | v         |
| F 7                      | 7195.112 360       |                                             | pulsante avviam./starting button      | 1         | 1         |
| F 8                      | ex 2900.070 - - -  | - - -                                       | sostituito da/superseded by - - ->    | v         | v         |
|                          | -> 2900.110 5000   | I                                           | cruscotto/dashboard                   | 1         | 1         |
| F 9                      | ex 6612.063 9040   | B                                           | -> fino a/until 02.93 -> CT D 050     | v         | v         |
| F 10                     | 8506.043 4350      |                                             | squadretta/angle bracket              | 1         | 1         |
| F 11                     | ex 6612.064 9040   | B                                           | -> fino a/until 02.93 -> CT D 050     | v         | v         |
| F 12                     | 9195.015 283       |                                             | termometro temp.testa/thermometer     | 1         | 1         |
| F 13                     | 1780.003 9         |                                             | bullone/bolt M 10 X 18                | 1         | 1         |
| F 14                     | 7565.011 9         |                                             | rondella/washer d. 10                 | 1         | 1         |
| F 15                     | 7245.353 560       |                                             | quadretto 12V - 3 spie/dashboard      | 1         | 1         |
|                          | 7245.356 560       |                                             | quadretto 12V - 6 spie/dashboard      | 1         | 1         |
| F 16                     | 4062.238 560       |                                             | fusibile/fuse 100 A                   | 1         | 1         |
| F 17                     | 3300.227 560       |                                             | dado/elongated nut                    | 1         | 1         |
| F 18                     | 3527.018 904       |                                             | distanziale/spacer                    | 1         | 1         |
| F 19                     | 8506.116 360       |                                             | squadretta supp.quadr./dashb.supp.    | 1         | 1         |
| F 20                     | 8506.119 560       |                                             | squadretta supp.quadr./dashb.supp.    | 1         | 1         |
| F 21                     | 5040.098 276       |                                             | interrut.press./press.switch(M 14)    | 1         | 1         |
| F 22                     | 4670.061 9         |                                             | guarnizione/copper gasket d.14        | 1         | 1         |
| F 23                     | 7330.083 279       |                                             | raccordo/union                        | 1         | 1         |
| F 24                     | 4776.090 360       |                                             | guarnizione/gasket                    | 1         | 1         |
| F 25                     | 5450.009 276       |                                             | manometro/manometer                   | 1         | 1         |
| Motore/Engine 12LD 435-2 |                    |                                             |                                       |           |           |
| " " 12LD 475-2           |                    |                                             |                                       |           |           |



**12LD 435-2 - 12LD 475-2**  
**vedi Tavola Ric./see Parts Table 1.5302.508**

| Pos. | Matricola/Part No.  | Note/Remarks                          | 12LD435-2 | 12LD475-2 |
|------|---------------------|---------------------------------------|-----------|-----------|
| F 26 | ex 5175.119 9040    | B -> dal/from 15.02.1993-> CT D 050-> | v         | v         |
|      | -> 5175.162 5000    | A lampada/lamp                        | 2         | 2         |
| F 27 | 7555.004 9          | rondella/washer                       | 2         | 2         |
| F 28 | 1760.003 9          | bullone/bolt M 6 X 1 X 12             | 2         | 2         |
| F 29 | 5041.020 2760       | interruttore/key switch               | 1         | 1         |
| F 30 | 6491.005 2830       | pipetta/pipe elbow                    | 1         | 1         |
| F 31 | 5840.089 435        | mot.avv./start.motor 12 V 1,7 KW      | 1         | 1         |
| F 32 | 9730.045 9          | vite/screw M 10 X 1,5 X 30            | 2         | 2         |
| F 33 | 1770.002 9          | bullone/bolt M 8 X 1,25 X 16          | 1         | 1         |
| F 34 | 7565.007 9          | rondella/washer                       | 1         | 1         |
| F 35 | 3617.045 2790       | fascetta/clamp                        | 2         | 2         |
| F 36 | 2569.203 435        | convogliatore/shroud                  | 1         | 1         |
| F 37 | 6927.056 360        | protezione/guard                      | 1         | 1         |
| F 38 | 1901.030 9          | bullone raccordo/union bolt M 10      | 1         | 1         |
| F 39 | 7565.011 9          | rondella/washer                       | 2         | 2         |
| F 40 | 6491.013 3600       | pipetta/pipe elbow                    | 1         | 1         |
| F 41 | ex 6745.031 - - - - | sostituito da/superseded by - - - ->  | v         | v         |
|      | -> 6745.050 107     | I pressostato/pressure switch oil     | 1         | 1         |
| F 43 | 4776.089 360        | guarnizione/gasket                    | 1         | 1         |
| F 44 | 4670.060 9          | guarnizione/copper gasket             | 1         | 1         |
| F 45 | 9790.039 9          | vite/screw M 6 X 1 X 12               | 7         | 7         |
| F 46 | 9790.039 9          | vite/screw M 6 X 1 X 12               | 7         | 7         |
| F 47 | 5066.074 435        | lamiera insonor./denoised airtight    | 1         | 1         |
| F 48 | 3350.094 435        | deflettore/deflector                  | 1         | 1         |
| F 49 | 5066.070 435        | lamiera insonor./denoised airtight    | 1         | 1         |
| F 50 | 3617.021 5000       | fascetta/strip fixing                 | 1         | 1         |
| F 51 | 9731.092 9          | vite/screw M 8 X 1,25 X 14            | 1         | 1         |
| F 52 | 1760.003 9          | bullone/bolt M 6 X 1 X 12             | 1         | 1         |
| F 56 | ex 1156.090 - - - - | sostituito da/superseded by - - - ->  | v         | v         |
|      | ex 1157.153 283     | B -> da/from s.No.3053960-> CT 1814-> | v         | v         |
|      | -> 1157.154 629     | A alternatore/volt.altern. 12V 12A    | 1         | 1         |
|      | ex 1157.041 560     | B -> da/from s.No.3053960-> CT 1814-> | v         | v         |
|      | -> 1157.167 560     | A alternatore/volt.altern. 12V 16A    | 1         | 1         |
| F 58 | 3203.050 9          | dado/nut                              | 1         | 1         |
| F 59 | 2670.027 560        | coperchio puleggia/pulley cover       | 1         | 1         |
| F 60 | 1760.094 9          | bullone/bolt                          | 1         | 1         |
| F 61 | 6927.242 435        | protezione fissa/flywheel guard       | 1         | 1         |
| F 62 | 5096.039 360        | protezione rotante/flywheel guard     | 1         | 1         |
| F 64 | 9790.039 9          | vite/screw M 6 X 1 X 12               | 4         | 4         |
| F 69 | ex 1760.003 9       | B -> da/from s.No.3053960-> CT 1814-> | v         | v         |
|      | -> 9731.022 9       | A vite/screw M 5 X 0,8 X 20           | 4         | 4         |
| F 70 | ex 7555.004 9       | B -> fino a/until 3053959-> CT 1814   | v         | v         |
| F 71 | 1760.003 9          | bullone/bolt M 6 X 1 X 12             | 1         | 1         |
| F 72 | ex 5168.023 360     | B -> da/from s.No.3053960-> CT 1814-> | v         | v         |
|      | -> 3617.152 435     | A fascetta/strip fixing               | 1         | 1         |
| F 73 | 8300.052 360        | supporto regolatore/support           | 1         | 1         |
| F 78 | 7051.060 360        | puleggia 1 gola/pulley                | 1         | 1         |
| F 79 | 6961.048 292        | puleggia avv.2 gole/start pulley      | 1         | 1         |
| F 80 | 1770.009 9          | bullone/bolt M 8 X 35                 | 4         | 4         |
| F 81 | 7565.007 9          | rondella/washer d. 8                  | 4         | 4         |
| F 82 | 6961.061 395        | puleggia avviamento/start pulley      | 1         | 1         |
| F 83 | 8300.049 360        | supporto regolatore/support           | 1         | 1         |
| F 84 | 8300.048 360        | sostegno/bracket                      | 1         | 1         |
| F 85 | ex 9730.015 9       | B -> da/from s.no.3053960-> CT 1814-> | v         | v         |
|      | -> 9732.078 9       | A vite/screw m 6 x 1 x 25             | 5         | 5         |
| F 86 | 2145.014 270        | cappuccio/rubber cap                  | 1         | 1         |
| F 87 | ex 6740.088 276     | B -> dal/from 15.12.1988-> CT 5149->  | v         | v         |
|      | -> 6740.153 2830    | A presa/inlet regul.Saprisa           | 1         | 1         |
|      | ex 6740.090 276     | B -> dal/from 15.12.1988-> CT 5149->  | v         | v         |
|      | -> 6740.154 2830    | A presa/inlet regul.Ducati            | 1         | 1         |

Motore/Engine 12LD 435-2  
 ,, ,, 12LD 475-2



12LD 435-2 - 12LD 475-2  
vedi Tavola Ric./see Parts Table 1.5302.508

| Pos. | Matricola/Part No. | Note/Remarks                                 | 12LD435-2 | 12LD475-2 |
|------|--------------------|----------------------------------------------|-----------|-----------|
| F 88 | ex 7362.066        | - - - - - sostituito da/superseded by - - -> | v         | v         |
|      | ex 7362.238        | - - - - - sostituito da/superseded by - - -> | v         | v         |
|      | -> 7362.228        | 283 I regolat./v.regul.12V 14A-6 contact     | 1         | 1         |
|      | 7362.298           | 107 regolat./v.regul.12V 16A-5 contact       | 1         | 1         |
| F 89 | 9732.092           | 9 vite/screw M 6 X 1 X 18                    | 2         | 2         |
| F 90 | 4936.077           | 435 ingranaggio/gear                         | 1         | 1         |
| F 91 | 8780.015           | 560 supporto ingranaggio/gear support        | 1         | 1         |
| F 92 | 1213.173           | 9 anello tenuta/seal ring 20X35X7            | 1         | 1         |
| F 93 | 7475.018           | 560 rinvio ad angolo/angle gear              | 1         | 1         |
| F 94 | 8903.050           | 560 supporto/angle gear support              | 1         | 1         |
| F 95 | 2292.003           | 276 tubo flessibile/flexible line            | 1         | 1         |
| F 96 | 2529.007           | 276 contagiri/revolution counter             | 1         | 1         |
| F 97 | 2185.893           | 560 prolunga (quadr.a 3 spie)/ext.wire       | 1         | 1         |
|      | 2185.882           | 107 prolunga (quadr.a 6 spie)/ext.wire       | 1         | 1         |
| F 98 | 2185.891           | 560 cavo (qudretto a 3 spie)wire ass.y       | 1         | 1         |
|      | 2185.873           | 560 cavo (qudretto a 3 spie)wire ass.y       | 1         | 1         |

fine/end

Motore/Engine 12LD 435-2

" " 12LD 475-2