

TAVOLA RICAMBI
TABLEAU PIECES DETACHEES
SPARE PARTS TABLE
ERSATZTEILTAFEL
TABLA DE REPUESTOS
TÁBUA PEÇAS DE TROCA

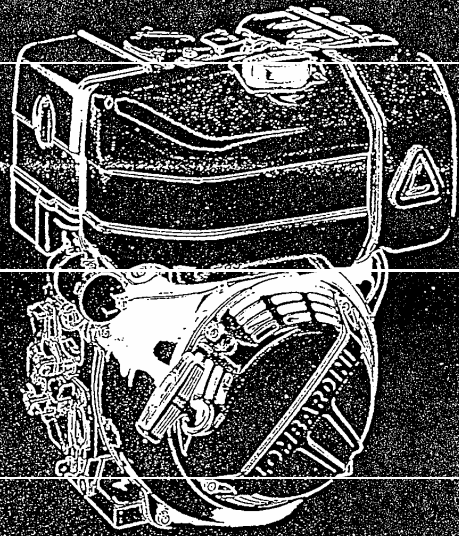

15LD225
15LD315
15LD350

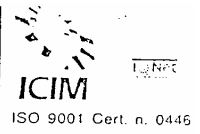

RICAMBI ORIGINALI



PEÇAS DE TROCA ORIGINAIS



PEÇAS DE TROCA ORIGINAIS



PEÇAS DE TROCA ORIGINAIS



PEÇAS DE TROCA ORIGINAIS



PEÇAS DE TROCA ORIGINAIS

A

15LD

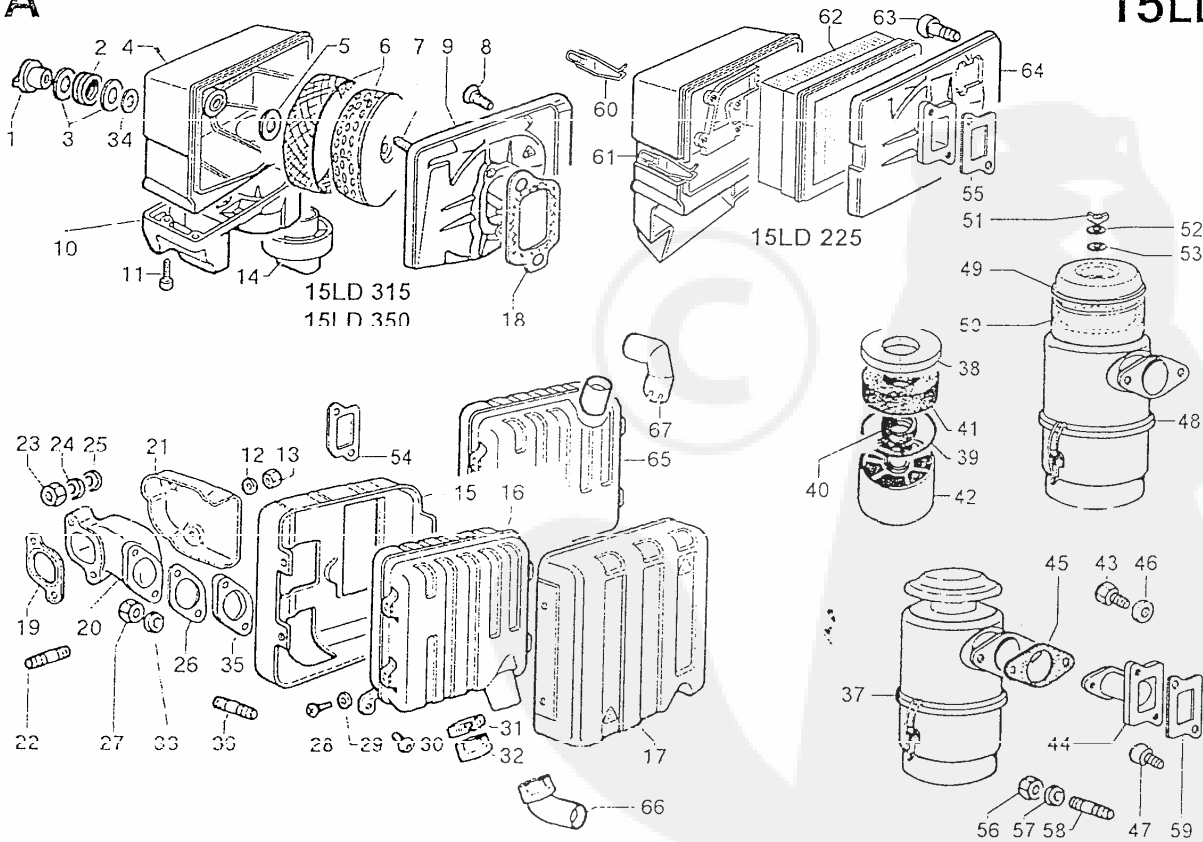

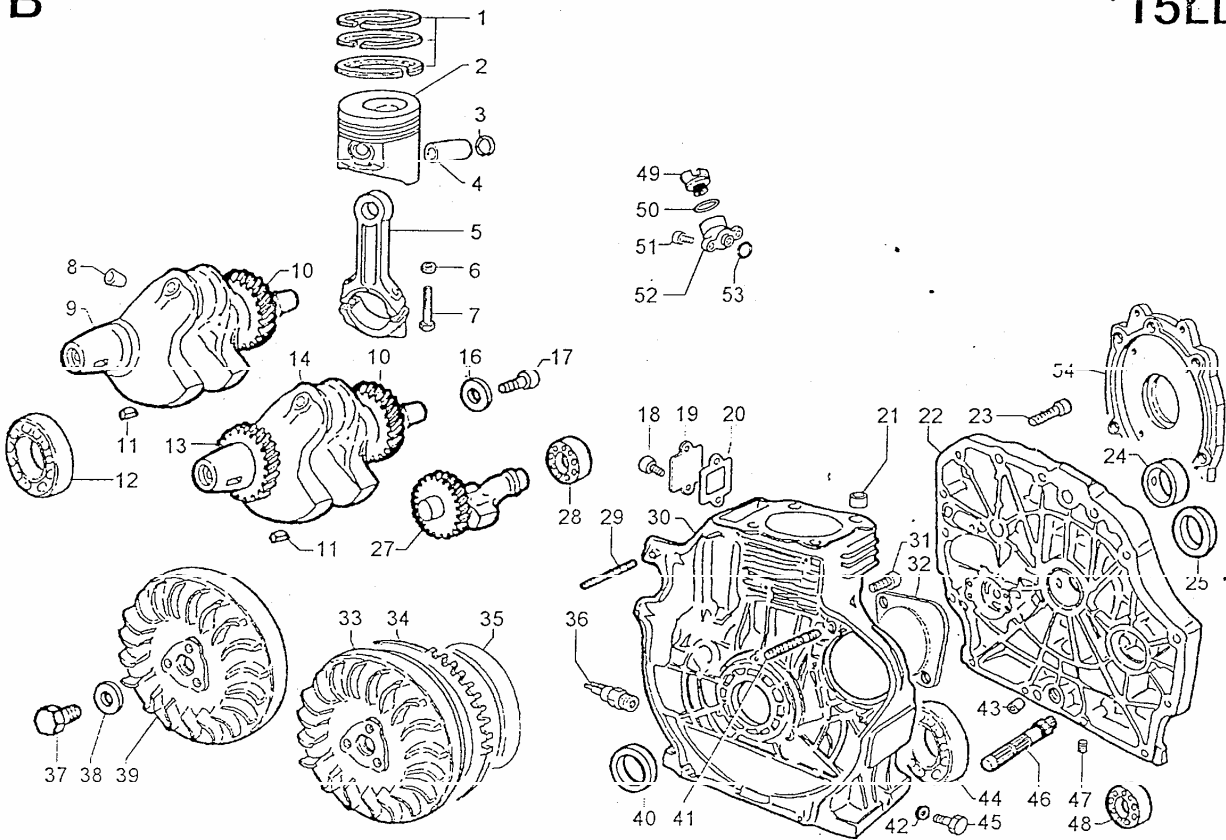
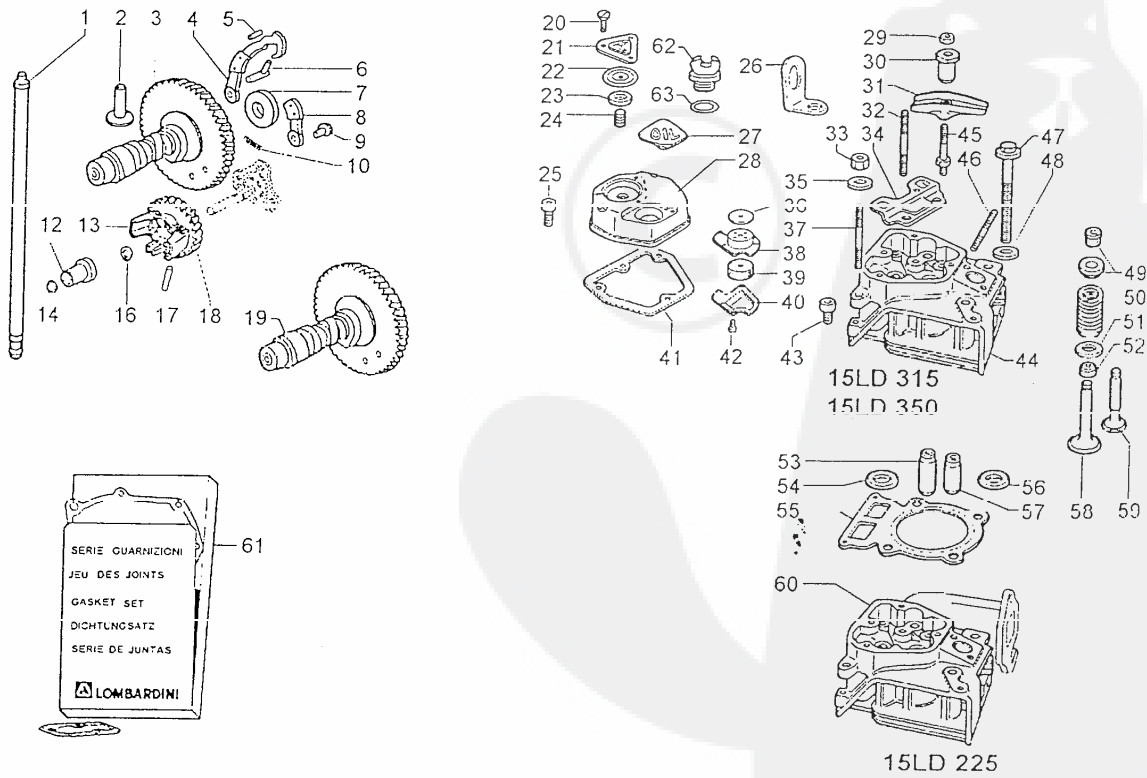
B**15LD****C****15LD**

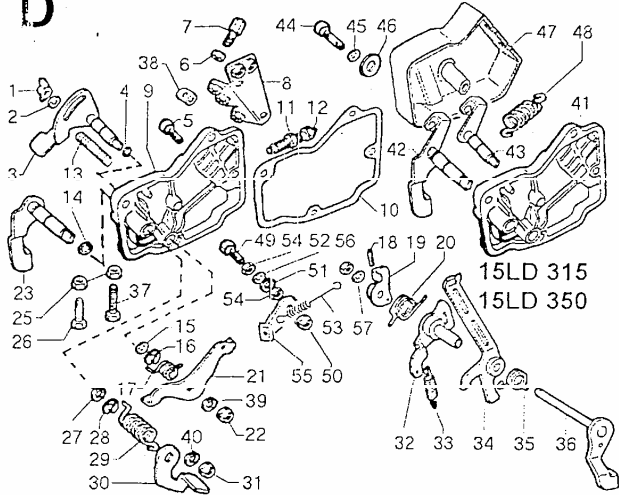
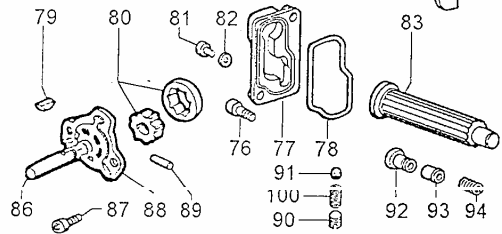
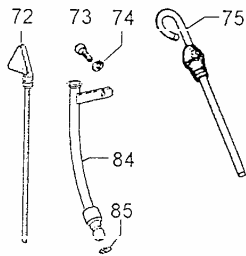
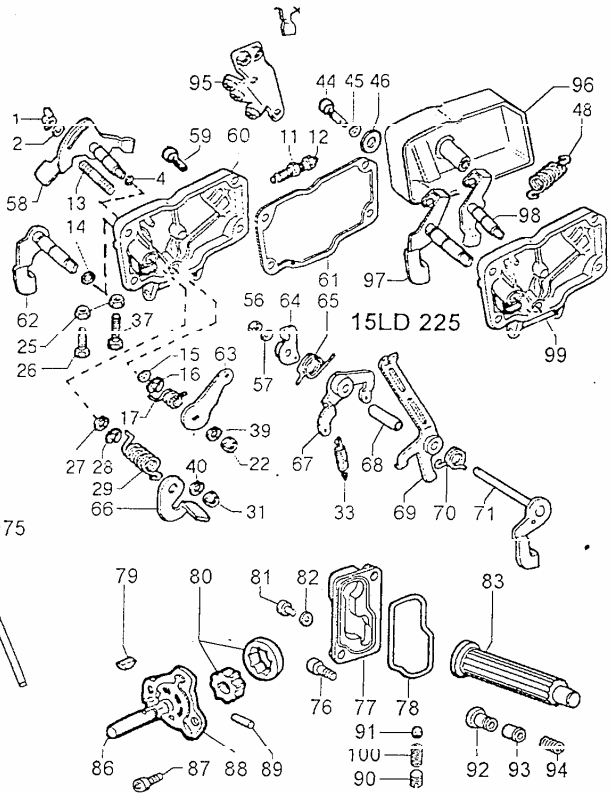
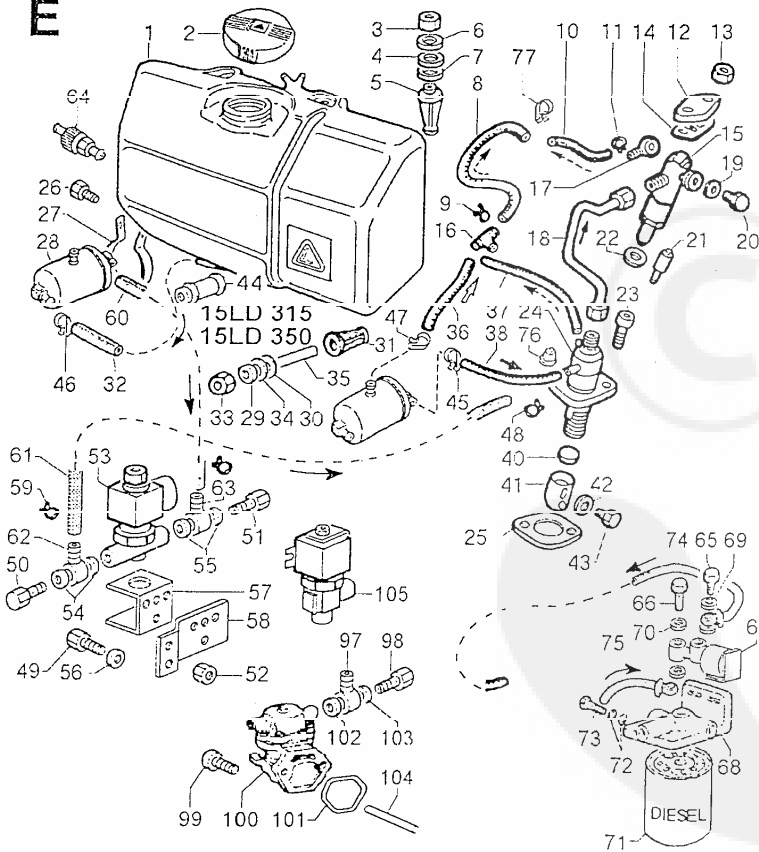
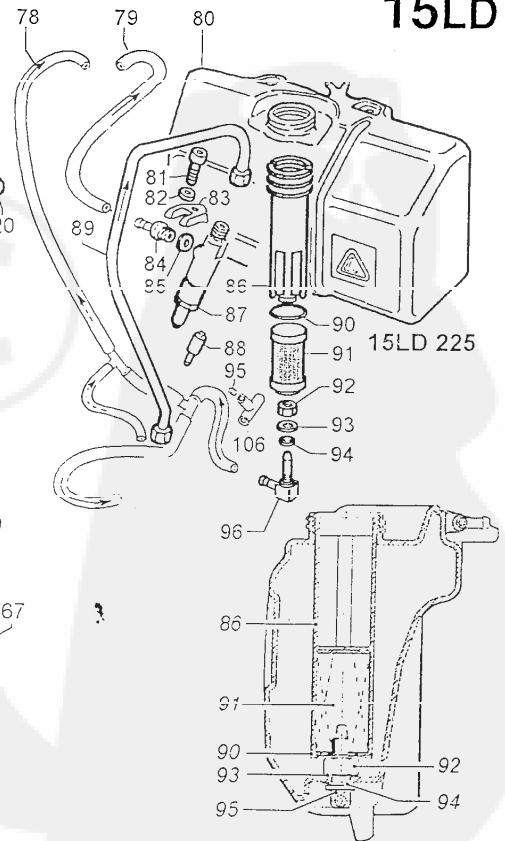
D**15LD****E****15LD**

F

15LD

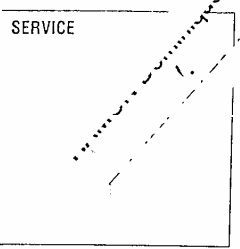
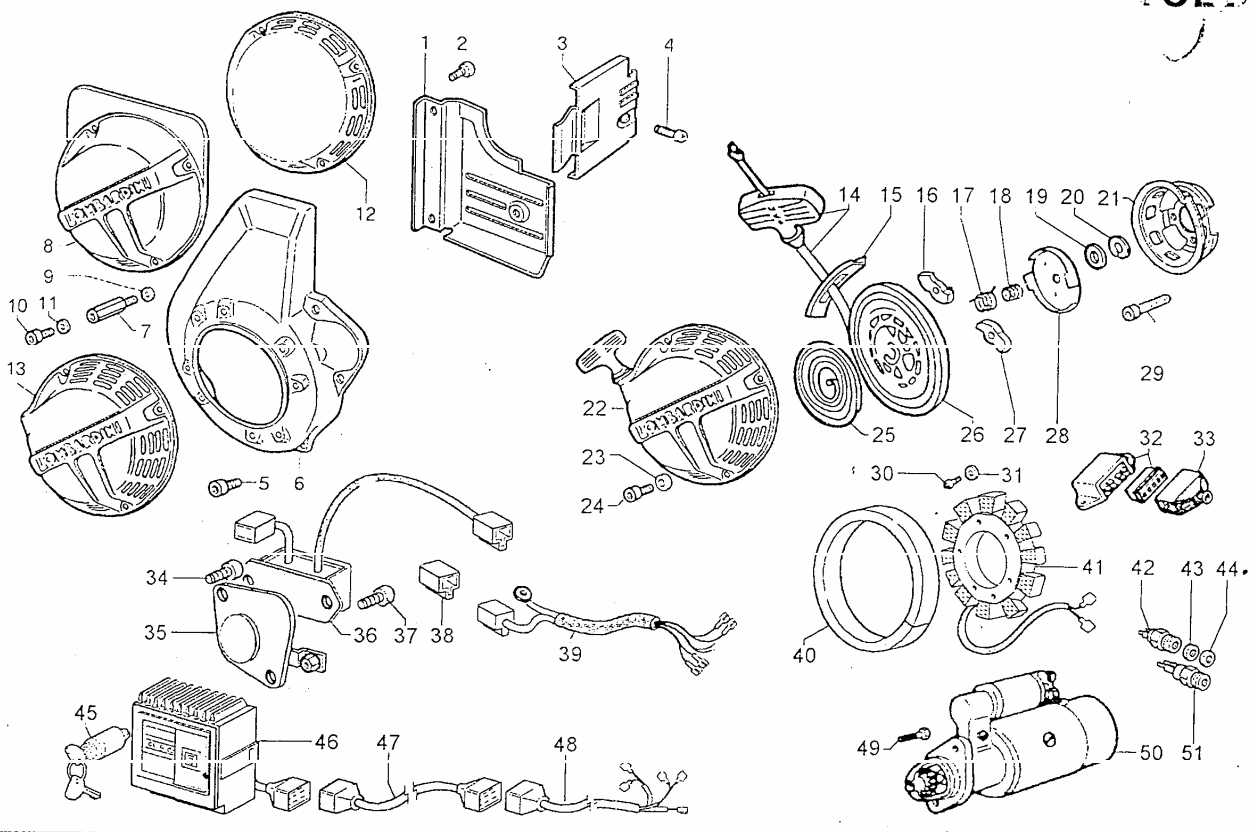

SERVICE

Per assistenza e ricambi rivolgersi a stazioni di servizio autorizzate Lombardini. N. tel. su libretto service e su pagine gialle.

Pour toute exigence de service après vente et pièces détachées s'adresser aux Stations de service du réseau Lombardini. N. de téléphone indiqué sur brochure relative au service après vente et annuaire catégorique.

For spare parts and after sale assistance contact authorized Lombardini service centers. Tel. No. appears on service booklet and telephone directory.

Für Service und Ersatzteile bitten wir, sich an autorisierte Werkstätte zu wenden. Telef. Nummer laut unserem Service - Büchlein und Fernsprechbuch.

Para asistencia y repuestos dirigirse a las estaciones de servicio autorizadas Lombardini. N. Tel. su libretto service y su hojas amarillas.

Para assistência e recâmbios dirigir-se às estações de serviço autorizadas Lombardini. Número telefone é sobre a caderneta de serviço e sobre as páginas amarelas.

ORDINI RICAMBI
 COMMANDES PIÉCES
 PART ORDERS
 E-TEIL BESTELLUNGEN
 PEDIDOS DE REPUESTOS
 PEDIDOS RECÂMBIOS

TIPO MOTORE - MATRICOLA
 TYPE DE MOTEUR - MATRICULE
 ENGINE TYPE - SERIAL NUMBER
 MOTOR TYP
 MOTORENNUMMER
 TIPO DEL MOTOR
 NUMERO DEL MOTOR
 TIPO DE MOTOR
 NUMERO DO MOTOR

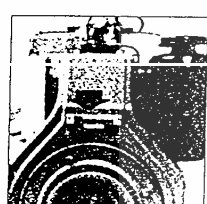

MATRICOLA DEL RICAMBIO
 REFERENCE DE LA PIÉCE
 SPARE PART NUMBER
 BESTELLNUMMER DES TEILES
 REFERENCIA DEL REPUESTO
 REFERÉNCIA DO RECÂMBIO

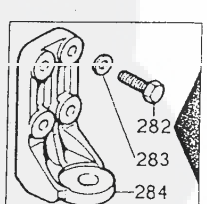
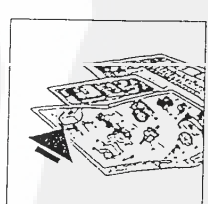

Disegni non impegnativi - Per applicazioni speciali consultare i Centri Assistenza e Ricambi.
 Les illustrations peuvent être modifiées - Pour les adaptations consulter les Agents Service.
 Drawings are subject to modifications - Pls contact Service Centers for special applications.
 Bildänderungen vorbehalten - Für Sonderanfertigungen sich an Service Werkstätten wenden.
 Ilustraciones pueden ser modificadas - Para aplicaciones especiales contactar a las Centros Repuestos.
 Desenhos podem ser alterados - Para aplicações especiais consultar os Centros de Assistência e Peças.

BERNARD
 SCRL Belg.-Lux. CVBA
 Rue E. Wautersstr. 126
 BRUX. 1020 BRUS.
 Tel. (02) 474 70 48 - Fax (02) 474 70 49



LOMBARDINI
 FABBRICA ITALIANA MOTORI S.p.A.
 42100 REGGIO EMILIA, ITALIA - CAS. POST. 1074
 Tel. (0522) 3891 - Teleg.: LOMBARMOTOR - Telex: 530003 MOTLOM I

LOMBARDINI USA INC.
 LOMBARDINI FRANCE S.A.
 LOMBARDINI MOTOREN GMBH
 LOMBARDINI (U.K.) LTD.
 HISPANOMOTOR S.A.

2150 Roggs Road, Bldg. 300, Suite 300 - Duluth, GA 30136, USA
 Zone Ind. Nord, Rue du Nizerland, Arnas - 69400 Villefranche S/Saône, France
 Bernerstr. 64 - 60437 Frankfurt/Main - Deutschland
 Unit 5, Ferry Mills, Osney Mead - Oxford OX2 0ES, U.K.
 Zona Industrial Cova Solera, s/n - 08191 RUBI-BARCELONA, España

ENTE COMPILATORE TECO ATL <i>fil</i>	COD. LIBRO 1.5302.498	MODELLI N° 50764	DATA EMISSIONE 10/04/1998	REVISIONE 00	DATA 10/04/1998	VISTO <i>P. M.</i>
---	--------------------------	---------------------	------------------------------	--------------	--------------------	-----------------------

vedi TAVOLA RIC./see SPARE P.TABLE/voir TABLEAU P.DETACH. 1.5302.498

 Aprile/April/Avril 1998

MOTORI/ENGINES/MOTEURS Gr.15

 Colonna/Column/Colonne 1 = 15LD 225
 " " " 2 = 15LD 315
 " " " 3 = 15LD 350

Vedi/See/Voir

 Libretto Uso e Man./Use-Maint.booklet/Livret Emploi-Entret. 1.5302.443
 Libretto Service/Service directory/Reseau S.A.V. 1.7968.002

-
- A - valido dal motore vedi Circolare Tecnica
 from engine S.No see Service Letter
 à partir du moteur voir Circulaire Technique
 - B - valido fino al motore vedi Circolare Tecnica
 up to engine s.No. see Service Letter
 jusqu'au moteur voir Circulaire Technique
 - I - intercambiabile vedi Circolare Tecnica
 interchangeable see Service Letter
 interchangeable voir Circulaire Technique
 - E - ad esaurimento/exhausting part/piece en epuisement.
 - npd non più disponibile/no longer available/non plus disponible
 - CT vedi circolare tecnica/see service letter/voir circulaire technique
-

 Descrizioni non impegnative/Subject to modifications/Modifications rùservées
 TECO/ATL/Assistenza Tecnica Lombardini/Aprile 1998

-
- Riquadro ASPIRAZIONE/SCARICO
 Drawing A INTAKE/EXHAUST
 Dessin A ADMISSION/ECHAPPEMENT

 - Riquadro BIELLA/PISTONE/ALBERO A GOMITO/VOLANO/BASAMENTO/FLANGIATURA
 Drawing B CONN.ROD/PISTON/CRANKSHAFT/FLYWHEEL/CRANKCASE/FLANGING
 Dessin B BIELLE/PISTON/VILEBREQUIN/VOLANT/CARTER/BRIDE

 - Riquadro TESTA/CAPPELLO BIL./VALVOLE/DISTRIBUZIONE/REG.GIRI
 Drawing C CYLINDER HEAD/ROCKER BOX/VALVES/TIMING/SPEED GOVERNOR
 Dessin C CULASSE/COUVERCLE CULB./SOUPAPES/DISTRIBUTION/REG.VITESSE

 - Riquadro COMANDI/CIRCUITO LUBRIFICAZIONE
 Drawing D CONTROLS/LUBRICATING SYSTEM
 Dessin D COMMANDES/CIRCUIT DE LUBIFICATION

 - Riquadro CIRCUITO COMBUSTIBILE
 Drawing E FUEL SYSTEM
 Dessin E CIRCUIT CARBURANT

 - Riquadro RAFFREDDAMENTO/AVVIAMENTO
 Drawing F COOLING SYSTEM/STARTING
 Dessin F CIRCUIT DE REFROIDISSEMENT/DEMARRAGE
-

 Tipo motore
 Engine type
 Type moteur

15LD 225

15LD 315

15LD 350

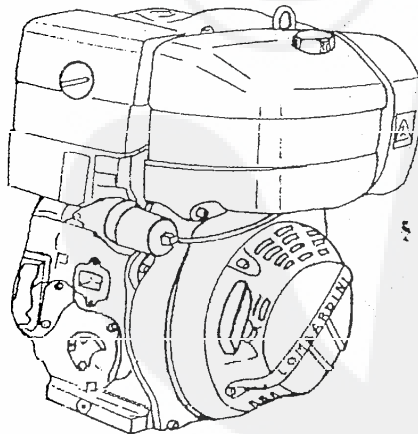
 Blocco motore
 Short block
 Bloc moteur

vedi ultima pagina

see last page

voir dernière page

 HAMON Dominique
 S.A.V.
 Tel. (02) 474 70 46



15LD 225 - 15LD 315 - 15LD 350
vedi Tavola Ric./see Parts Table 1.5302.498

Pos.	Matricola/Part No.	Note/Remarks	15LD 225	15LD 315	15LD 350
A 1+	6560.036 196	pomello chiusura filtro/knob	-	1	1
A 2+	5660.067 196	molla richiamo filtro/spring	-	1	1
A 3+	7625.271 196	rondella per molla/washer	-	2	2
A 4	ex 2750.310 - - - - -	sostituito da/superseded by - - - - - >	v	v	
	->=2750.326 196 I	COPERCHIO FILT.ARIA/AIR CLEAN.COVER (Pos. 1-2-3-4-10-11-14-34)	-	1	1
	->=2750.354 197	SPECIALE (senza prefiltro e deflett.) SPECIAL (without prefilter/deflector) (Pos. 1-2-3-4-14)			1
A 5	7626.047 9	rondella/washer d.6,2	-	1	1
A 6	ex 2175.128 - - - - -	sostituito da/superseded by - - - - - >	v	v	
	ex 2175.154 - - - - -	sostituito da/superseded by - - - - - >	v	v	
	ex 2175.173 - - - - -	sostituito da/superseded by - - - - - >	v	v	
	-> 2175.176 196 I	cartuccia aria/air cleaner element	-	1	1
A 7	6760.085 9	prigioniero/stud M 6 X 20	-	1	1
A 8	9800.112 986	vite/screw M 8 X 16	-	2	2
A 9	8836 228 196	supporto filtro aria/support	-	1	1
A 10+	ex 6727.041 - - - - -	non disp./not avail. vedi/see Pos. 4			
A 11+	9730.004 9 or	vite/screw M 5 X 16	-	5	5
	9820.172 9	vite autofil./screw 4 X 20	-	5	5
A 12	4480.003 9	guarnizione in fibra/fibre gasket	-	2	2
A 13	ex 3203.047 - - - - -	sostituito da/superseded by - - - - - >	v	v	
	-> 3240.164 9 I	dado/nut M 8	-	2	2
A 14+	ex 3350.127 - - (npd) - -	vedi/see Pos. A 4	-	v	v
A 15	6927.318 196	protez.l.entrata gas/muffler guard	1	1	1
A 16	5460.493 194	marmitta/muffler	1	-	-
	ex 5460.448 - - - - -	sostituito da/superseded by - - - - - >	-	v	v
	-> 5460.496 196 I	marmitta/muffler	-	1	1
A 17	6927.319 196	protez.l.uscita gas/muffler guard	1	1	1
A 18	4490.084 196	guarn.filt.aria/air cleaner gasket	-	1	1
A 19	4501.101 196	guarnizione/gasket	-	1	1
A 20	2486.315 196	collettore scarico/exhaust manifold	-	1	1
A 21	6927.345 196	protez.collett.scar./exh.manif.guard	-	1	1
A 22	6780 084 9	prigioniero/stud M 8 X 40	-	2	2
A 23	ex 3203.095 - - - - -	sostituito da/superseded by - - - - - >	-	v	v
	-> 3240.163 9 I	dado/nut M 8	-	2	2
A 24	7625.010 9	rondella/washer d.8	-	2	2
A 25	4480.003 9	guarnizione in fibra/fibre gasket	-	2	2
A 26	4501.113 196	guarnizione/gasket	-	1	1
A 27	ex 3203.095 - - - - -	sostituito da/superseded by - - - - - >	-	v	v
	-> 3240.163 9 I	dado/nut M 8	-	2	2
A 28+	9790.037 9	vite/screw M 6 x 8	4	4	4
A 29+	7555.027 9	rondella/washer d.6,4	4	4	4
A 30	9732.074 9	vite/screw M 8 X 20	1	1	1
A 31	3630.156 9	fascetta/clamp 20-32	1	1	1
A 32	9602.151 196	tubo parafiamma/spark arrestor guard	1	1	1
A 33	ex 7555.007 - - - - -	sostituito da/superseded by - - - - - >	v	v	
	-> 7555.029 9	rondella/washer d.8	-	2	2
A 34+	7625.277 196	rondella per pomello/washer	-	1	1
A 35	3815.079 196	flangia/exhaust flange	-	1	1
A 36	6780.012 9	prigioniero/stud M 8 X 25	-	2	2
A 37	=3700.386 194	FILTRO ARIA/AIR CLEANER (diam.105)	1	-	-
	ex=3700.360 283 E ->	da/from s.No. 3958584 -> CT 150005 ->	v	v	
	->=3700.373 292 I	FILTRO ARIA/AIR CLEANER (diam.122) (Pos. 37-38-39-40-41-42)	-	1	1
A 38+	5496.220 283	massa filtr.sup.spugna/filt.element	1	-	-
	ex 5496.220 283 B ->	da/from s.No. 3958584 -> CT 150005 ->	v	v	
	-> 5496.333 292 A	massa filtr.sup.spugna/filt.element	-	1	1
Motore/Engine	15LD 225			
Motore/Engine	15LD 315			
Motore/Engine	15LD 350			



15LD 225 - 15LD 315 - 15LD 350
vedi Tavola Ric./see Parts Table 1.5302.498

Pos.	Matricola/Part No.	Note/Remarks	15LD 225	15LD 315	15LD 350
A 39+	1261.097 283	distanziale/spacer	1	-	-
	ex 1261.097 283 B	-> da/from s.No. 3958584 -> CT 150005 ->	-	v	v
	-> 1261.072 500 A	distanziale/spacer	-	1	1
A 40+	4775.522 283	anello tenuta/seal ring	1	-	-
	ex 4775.522 283 B	-> da/from s.No. 3958584 -> CT 150005 ->	-	v	v
	-> 4775.120 500 A	anello tenuta/seal ring	-	1	1
A 41+	5496.342 283	massa filt.inferiore/filt.element	1	-	-
	ex 5496.221 283 B	-> da/from s.No. 3958584 -> CT 150005 ->	-	v	v
	-> 5496.071 500 A	massa filt.inferiore/filt.element	-	1	1
A 42+	5496.225 283	massa filtr.sup.feltro/filt.element	1	-	-
	ex 5496.225 283 B	-> da/from s.No. 3958584 -> CT 150005 ->	-	v	v
	-> 5496.334 292 A	massa filtr.sup.feltro/filt.element	-	1	1
A 43	1770.005 9	bullone/bolt M 8 X 22	2	2	2
A 44	3902.331 194	flangia/flange	1	-	-
	ex 3902.318 - - - - -	sostituito da/superseded by - - - - ->	-	v	v
	-> 3902.326 196 I	flangia/flange	-	1	1
A 45	4500.067 271	guarnizione/gasket	1	1	1
A 46	7565.007 9	rondella/washer d.8	-	2	2
A 47	9732.074 9	vite/screw M 8 X 20	-	2	2
A 48	3700.374 222	FILTRO ARIA/AIR CLEANER (diam.122), (Pos. 38-39-40-41-42-48-49-50-51-52-53)	-	1	1
A 49+	2125.055 500	cappellotto/cap	-	1	1
A 50+	1301.053 500	prefiltro/cyclonic prefilter	-	1	1
A 51+	3200.002 9	dado ad alette/nut	-	1	1
A 52+	7625.092 9	rondella/washer	-	1	1
A 53+	4775.137 914	guarnizione/joint	-	1	1
A 54	4501.129 194	guarnizione/gasket	1	-	-
A 55	4490.088 194	guarn.filt.aria/air cleaner gasket	1	-	-
A 56	3240.164 9	dado/nut M 8	2	-	-
A 57	7565.007 9	rondella/washer d.8	2	-	-
A 58	6780.159 9	prigioniero/stud M 8	2	-	-
A 59	4490.088 194	guarn.filt.aria/air cleaner gasket	1	-	-
A 60	4115.070 194	gancio/hook	2	-	-
A 61	2750.358 194	coperchio filtro aria/air cl. cover	1	-	-
A 62	2175.167 194	cartuccia aria/air cleaner element	1	-	-
A 63	9732.074 9	vite/screw M 8 X 20	2	-	-
A 64	8836.267 194	supporto filtro aria/air cl. support	1	-	-
A 65	5460.509 194	marmitta scarico in alto/upward muff	1	-	-
	5460.477 196	marmitta scarico in alto/upward muff	-	1	1
A 66	9170.104 196	terminale scarico/exhaust pipe	1	1	1
A 67	9170.110 196	terminale scarico/exhaust pipe	1	1	1
B 1+	8211.251 194	serie segmenti/ring set std.	1	-	-
	8211.252 194	serie segmenti/ring set +0,50	1	-	-
	8211.253 194	serie segmenti/ring set +1,00	1	-	-
	8211.227 196	serie segmenti/ring set std.	-	1	-
	8211.228 196	serie segmenti/ring set +0,50	-	1	-
	8211.229 196	serie segmenti/ring set +1,00	-	1	-
	8211.239 197	serie segmenti/ring set std.	-	-	1
	8211.240 197	serie segmenti/ring set +0,50	-	-	1
	8211.241 197	serie segmenti/ring set +1,00	-	-	1

Motore/Engine 15LD 225
 Motore/Engine 15LD 315
 Motore/Engine 15LD 350



15LD 225 - 15LD 315 - 15LD 350
vedi Tavola Ric./see Parts Table 1.5302.498

Pos.	Matricola/Part No.	Note/Remarks	15LD 225	15LD 315	15LD 350
B 2	=6501.538 194	PISTONE COMPLETO/PISTON SET std.	1	-	-
	=6501.539 194	PISTONE COMPLETO/PISTON SET +0,50	1	-	-
	=6501.540 194	PISTONE COMPLETO/PISTON SET +1,00	1	-	-
	=6501.250 196	PISTONE COMPLETO/PISTON SET std.	-	1	-
	=6501.251 196	PISTONE COMPLETO/PISTON SET +0,50	-	1	-
	=6501.252 196	PISTONE COMPLETO/PISTON SET +1,00	-	1	-
	=6501.337 196	std per vettoretta/for minicar	-	1	-
	=6501.338 196	+0,50 per vettoretta/for minicar-	-	1	-
	=6501.339 196	+1,00 per vettoretta/for minicar	-	1	-
	=6501.487 197	PISTONE COMPLETO/PISTON SET std.	-	-	1
	=6501.489 197	PISTONE COMPLETO/PISTON SET +0,50	-	-	1
	=6501.489 197	PISTONE COMPLETO/PISTON SET +1,00 (Pos. 1-2-3-4)	-	-	1
B 3+	1160.057 196	anello/circlip	2	2	-
	1160.061 197	anello/circlip	-	-	2
B 4+	8480.099 194	spinotto/piston pin	1	-	-
	8480.089 196	spinotto/piston pin	-	1	-
	8480.098 197	spinotto/piston pin	-	-	1
B 5	=1526.196 194	BIELLA COMPLETA/CONNECT.ROD std.	1	-	-
	=1526.207 194	BIELLA COMPLETA/CONNECT.ROD -0,25	1	-	-
	=1526.208 194	BIELLA COMPLETA/CONNECT.ROD -0,50	1	-	-
	=1526.155 196	BIELLA COMPLETA/CONNECT.ROD std.	-	1	-
	=1526.163 196	BIELLA COMPLETA/CONNECT.ROD -0,25	-	1	-
	=1526.164 196	BIELLA COMPLETA/CONNECT.ROD -0,50	-	1	-
	=1526.204 196	BIELLA COMPLETA/CONNECT.ROD std.	-	-	1
	=1526.205 196	BIELLA COMPLETA/CONNECT.ROD -0,25	-	-	1
	=1526.206 196	BIELLA COMPLETA/CONNECT.ROD -0,50 (Pos. 5-6-7)	-	-	1
B 6+	7626.048 9	rondella/connect.rod washer	-	2	2
B 7+ ex	1770.148 - - - - -	non disp./not avail. vedi/see Pos. 5	-	-	-
B 8+	9080.132 9	tappo/plug d.6	1	1	1
B 9	=1050.986 194	ALBERO GOMITO/CRANKSHAFT std.	1	-	-
	=1050.855 196	ALBERO GOMITO/CRANKSHAFT std. (Pos. 8-9-10-11)	-	1	1
B 10+ ex	4936.219 - - - - -	non disp./not avail.vedi/see Pos.9/14	-	-	-
B 11+	2280.067 9	chiavetta/key 5 X 7,5 X 19	1	1	1
B 12	3002.079 9	cuscinetto/ball bearing 6207-C3	1	-	-
	3002.058 9	cuscinetto/ball bearing 6307-C3	-	1	1
B 13+ ex	4936.222 - - - - -	non disp./not avail. vedi/see Pos.14	-	-	-
B 14	=1050.987 194	ALBERO GOMITO COMPLETO per motore	1	-	-
	=1050.856 196	con equilibratore CRANKSHAFT ASS.Y for engine with equalizer device (Pos. 8-10-11-13-14)	-	1	1
B 16	7625.060 9	rondella/washer	1	1	1
B 17	1770.039 9	bullone/bolt M 8 X 28	1	1	1
B 18	9730.024 9	vite/screw M 8 X 16	2	2	2
B 19	3800.037 196	flangia/flange	1	1	1
B 20	4400.059 196	guarnizione/gasket	1	1	1
B 21	1970.140 107	bussola centraggio/sleeve	2	2	2
B 22	=6645.567 194	PORTINA/CRANKCASE COVER	1	-	-
	ex 6645.472 - - - - -	sostituito da/superseded by - - - - - >	-	v	v
	->=6645.566 196 I	PORTINA/CRANKCASE COVER (Pos. 22-24 std-47)	-	1	1
Motore/Engine	15LD 225			
Motore/Engine	15LD 315			
Motore/Engine	15LD 350			



15LD 225 - 15LD 315 - 15LD 350
vedi Tavola Ric./see Parts Table 1.5302.498

Pos.	Matricola/Part No.	Note/Remarks	15LD 225	15LD 315	15LD 350
B 23	9732.063 9	vite/screw M 8 X 35	14	-	-
	9730.031 9	vite/screw M 8 X 40	-	14	14
B 24+	-> 1611.196 194	bronzina/bearing std.	1	-	-
	1611.197 194	bronzina/bearing 0,25	1	-	-
	1611.198 194	bronzina/bearing -0,50	1	-	-
	1611.199 194	bronzina/bearing -1,00	1	-	-
	ex 1611.175 - - - - -	sostituito da/superseded by - - - - ->	-	v	-
	-> 1611.185 196 I	bronzina/bearing std.	-	1	1
	1611.180 196	bronzina/bearing -0,25	-	1	1
	1611.181 196	bronzina/bearing -0,50	-	1	1
	1611.186 196	bronzina/bearing -1,00	-	1	1
B 25	1213.345 196	anello paraol./seal ring 28x40x7	1	1	1
B 27	1111.206 194	albero equil.compl./equalizer shaft	1	-	-
	1111.177 196	albero equil.compl./equalizer shaft	-	1	1
B 28	vedi/see Pos. 48	-	-	-
B 29	6780.175 194	prigioniero/stud M 8 X 52	1	-	-
	6760.099 196	prigioniero/stud M 6 X 48	-	1	1
	6780.169 196	prigioniero/stud M 8 X 48	-	1	1
B 30	1510.820 194	basamento/crankcase	1	-	-
	1510.821 194	basamento rif.olio laterale/crankcase	1	-	-
	1510.704 196	basamento/crankcase	-	1	-
	1510.784 197	basamento/crankcase	-	-	1
B 31	9732.041 9	vite/screw M 10 X 18	-	2	2
B 32	3800.036 196	flangia chiusura foro/flange	-	1	1
B 33	=9881.217 194	VOLANO CON CORONA-predisp.per rotore FLYWHEEL WITH CROWN-suitable for alternator rotor	1	-	-
	ex 9880.886 196 B	-> da/from s.No. 3582963 -> CT 150001 ->	-	v	-
	->=9881.118 196 A	VOLANO CON CORONA-predisp.per rotore FLYWHEEL WITH CROWN-suitable for alternator rotor	-	1	1
	ex 9880.995 196 B	-> da/from s.No. 3582963 -> CT 150001 ->	-	v	-
	->=9881.120 196 A	VOLANO CON CORONA-per minivetture predisposto per rotore FLYWHEEL WITH CROWN-for minicars/suitable for alternator rotor (Pos. 33-34)	-	1	1
B 34+	-> 2816.107 194	corona avviamento/crown gear Z=91	1	-	-
	ex 2816.172 196 B	-> da/from s.No. 3582963 -> CT 150001 ->	-	v	-
	-> 2816.102 196 A	corona avviamento/crown gear Z=94	-	1	1
B 35	vedi/see Pos. F 40	-	-	-
B 36	vedi/see Pos. F 51	-	-	-
B 37	1800.030 9	bullone/bolt M 14 X 35 sin.	1	1	1
B 38	7626.043 9	rondella/waher d.14.5	1	1	1
B 39	9881.216 194	volano/flywheel (standard)	1	-	-
	9880.863 196	volano/flywheel (standard)	-	1	1
	9880.900 196	volano predisp.per rotore alternat. flywheel suitable for altern.rotor	-	1	1
	ex	-> da/from s.No. 3582963 -> CT 150001 ->	-	v	-
	-> 9881.134 196 A	volano alleggerito pred. per rotore lit flywheel suitable for alt.rotor	-	1	1
B 40	ex 1213.344 - - - - -	sostituito da/superseded by - - - - ->	-	v	-
	-> 1213.361 196 I	anello paraol./seal ring 35X52X7	1	1	1
B 41	6780.175 194	prigioniero/stud M 8 X 52	1	-	-
	6760.099 196	prigioniero/stud M 6 X 48	-	1	1
	6780.170 196	prigioniero/stud M 8 X 48	-	1	1
B 42	4350.007 9	guarnizione/gasket	2	2	2
B 43	1970.338 196	boccola/bushing	2	2	2
B 44	vedi/see Pos. 12	-	-	-
B 45	9040.012 183	tappo/plug M 14	2	2	2

Motore/Engine 15LD 225
Motore/Engine 15LD 315
Motore/Engine 15LD 350



15LD 225 - 15LD 315 - 15LD 350
vedi Tavola Ric./see Parts Table 1.5302.498

Pos.	Matricola/Part No.	Note/Remarks	15LD 225	15LD 315	15LD 350
B 46	3740.109 196	filtro aspiraz. olio/oil filter	1	1	1
B 47+	9765.108 9	vite/screw M 10 X 1,5	2	1	1
B 49	3002.077 9	cusc.alb.controrot./equal.shaft bear.	2	2	2
B 49	9032.086 196	anello OR 3106/O ring	1	-	-
B 50	1200.082 9	anello OR 3106/O ring	1	-	-
B 51	9730.010 9	vite/screw M 6 X 16	2	-	-
B 52	1570.059 194	bocchettone riempimento/oil pipe	1	-	-
B 53	1201.084 9	anello OR 132/O ring	1	-	-
B 54	6260.038 183	piastra flangiatura/flanging plate	1	-	-
C 1	1410.144 194	asta punteria/tie rod	2	-	-
	1410.124 - - - - -	sostituito da/superseded by - - - - - >	-	v	v
	1410.143 196	asta punteria/tie rod	-	2	2
C 2	7215.098 196	punteria/push rod	2	2	2
C 3	=1011.448 194	ALBERO A CAMME COMPL. DI DECOMPRESS.	1	-	-
	=1011.360 196	CAMSHAFT WIHT COMPRESSION RELEASE	-	1	1
		(Pos. 3-4-5-6-7-8-9-10)			
C 4+	vedi/see pos. 3			
C 5+	vedi/see pos. 3			
C 6+	vedi/see pos. 3			
C 7+	1301.245 147	anello rasam/thrust-washer d.14	1	1	1
C 8+	vedi/see pos. 3			
C 9+	vedi/see pos. 3			
C 10+	5660.064 196	molla/spring			
C 12	=7200.156 196	PUNTALINO COMPLETO/DRIVE ROD ASS.Y (Pos. 12-14)	1	1	1
C 13	ex 5496.212 - - - - -	non disp./not avail. vedi/sec Pos. 16			
C 14+	vedi/see Pos. 12			
C 16	1240.002 9	anello seeger/snap ring d.8	1	1	1
C 17+	7770.171 196	rullino/roller 3 X 27,8	2	2	2
C 18	ex 4936.220 - - - - -	sostituito da/superseded by - - - - - >		v	v
	->=4896.328 196 I	GRUPPO REGOLATORE/GOVERNOR ASS.Y (Pos. 13-17-18)	1	1	1
C 19	1011.447 194	albero camme (senza decompressione)	1	-	-
	1011.359 196	camshaft (without compress. release)	-	1	1
C 20+	vedi/see Pos. 28			
C 21+	vedi/see Pos. 28			
C 22+	vedi/see Pos. 28			
C 23+	vedi/see Pos. 28			
C 24+	vedi/see Pos. 28			
C 25	9732.016 9	vite/screw M 6 X 10	3	3	3
C 26	8506.003 904	squadretta/lift eye	1	1	1
C 27	9032.068 196	tappo olio/filler oil cap	1	1	1
C 28	=2125.252 196	CAPPELLO COMPL./ROCK.ARM COVER ASS.Y (Pos. 20-21-22-23-24-36-38-39-40-42)	1	1	1
C 29	3240.161 196	dado/safety nut	2	2	2
C 30	3300.222 196	dado/special nut	2	2	2
C 31	1541.176 196	bilancere/rocker arm	2	2	2

Motore/Engine 15LD 225
 Motore/Engine 15LD 315
 Motore/Engine 15LD 350



15LD 225 - 15LD 315 - 15LD 350
vedi Tavola Ric./see Parts Table 1.5302.498

Pos.	Matricola/Part No.	Note/Remarks	15LD 225	15LD 315	15LD 350
C 32	6780.175 194	prigioniero/stud M 8 X 52	1	-	-
	6780.027 9	prigioniero/stud M 8 X 50	-	1	1
C 33	ex 3203.047 - - - - -	sostituito da/superseded by - - - - - >	-	v	-
	-> 3240.164 9 I	dado/nut M 8	-	2	2
C 34	5151.111 194	lamiera guida aste/panel	1	-	-
	5151.100 196	lamiera guida aste/panel	-	1	1
C 35	7625.061 9	rondella/washer d.8,4	1	1	1
C 36+	vedi/see Pos. 28	-	-	-
C 37	ex 6780.028 - - - - -	sostituito da/superseded by - - - - - >	-	v	-
	-> 6780.164 9 I	prigioniero/stud M 8 X 55	1	1	1
C 38+	vedi/see Pos. 28	-	-	-
C 39+	vedi/see Pos. 28	-	-	-
C 40+	vedi/see Pos. 28	-	-	-
C 41	4400.058 196	guarniz.cappel./gasket	1	1	1
C 42+	9820.077 90	vite/screw M 2,9 X 6,5	5	5	5
C 43	9732.078 9	vite/screw M 6 X 25	-	2	2
C 44	=9200.487 196	TESTA CON SEDI E GUIDE CYLINDER HEAD WITH SEATS AND GUIDES (Pos. 44-53-54-56-57)	-	1	1
C 45	9850.116 196	vite registro/adjustment screw	2	2	2
C 46	6760.100 9	prigioniero/stud M 6 X 45	-	2	2
C 47	1862.151 194	bullone/fixing head bolt	4	-	-
	1862.146 196	bullone/fixing head bolt	-	4	4
C 48	7625.130 105	rondella/washer	4	4	4
C 49	6410.111 194	piattello semic./cup-half colletts	2	-	-
	6410.108 196	piattello semic./cup-half colletts	-	2	2
C 50	5755.117 196	molla valvola/valve spring	2	2	2
C 51	3430.114 196	dischetto/cup	2	2	2
C 52	1261.101 210	anello tenuta/valve seal	2	-	-
	4535.015 107	guarnizione/valve gasket	-	2	2
C 53+	4845.240 194	guida valv.asp./inlet valve guide	1	-	-
	4845.218 196	guida valv.asp./inlet valve guide	-	1	1
C 54+	8000.207 194	sede valv.aspir./inlet valve seat	1	-	-
	8000.174 196	sede valv.aspir./inlet valve seat	-	1	1

Motore/Engine 15LD 225
Motore/Engine 15LD 315
Motore/Engine 15LD 350



15LD 225 - 15LD 315 - 15LD 350
vedi Tavola Ric./see Parts Table 1.5302.498

Pos.	Matricola/Part No.	Note/Remarks	15LD 225	15LD 315	15LD 350
C 55	4730.606 194	guarn.testa/head gask.0,9 d.69,5 (0)	1	-	-
	4730.607 194	guarn.testa/head gask.1,0 d.69,5 (1)	1	-	-
	4730.608 194	guarn.testa/head gask.1,1 d.69,5 (2)	1	-	-
	4730.609 194	guarn.testa/head gask.1,2 d.69,5 (3)	1	-	-
	4730.473 196	guarn.testa/head gask.0,9 d.78,5 (0)	-	1	-
	4730.474 196	guarn.testa/head gask.1,0 d.78,5 (1)	-	1	-
	4730.475 196	guarn.testa/head gask.1,1 d.78,5 (2)	-	1	-
	4730.476 196	guarn.testa/head gask.1,2 d.78,5 (3)	-	1	-
	4730.650 196	guarn.testa/head gask.0,9 d.79,5 (0)*	-	1	-
	4730.652 196	guarn.testa/head gask.1,0 d.79,5 (1)*	-	1	-
	4730.654 196	guarn.testa/head gask.1,1 d.79,5 (2)*	-	1	-
	4730.656 196	guarn.testa/head gask.1,2 d.79,5 (3)*	-	1	-
	4730.551 197	guarn.testa/head gask.1,0 d.82,5 (0)	-	-	1
	4730.552 197	guarn.testa/head gask.1,1 d.82,5 (1)	-	-	1
	4730.553 197	guarn.testa/head gask.1,2 d.82,5 (2)	-	-	1
	4730.554 197	guarn.testa/head gask.1,3 d.82,5 (3)	-	-	1
	4730.667 197	guarn.testa/head gask.1,0 d.83,5 (0)*	-	-	1
	4730.668 197	guarn.testa/head gask.1,1 d.83,5 (1)*	-	-	1
	4730.669 197	guarn.testa/head gask.1,2 d.83,5 (2)*	-	-	1
	4730.670 197	guarn.testa/head gask.1,3 d.83,5 (3)*	-	-	1
		(0) senza intagli/no semicircular cut			
		(1) 1 intaglio/semicircular cut			
		(2) 2 intagli/semicircular cuts			
		(3) 3 intagli/semicircular cuts			
		* + 1 mm sul diam.interno per rettificata camicia cilindro I° e II° maggiorazione.			
		* + 1 mm on the internal diameter - to be used for 1st and 2nd oversized cylinder liner.			
C 56+	8000.208 194	sede valv.scar./exh.valve seat	1	-	-
	8000.175 196	sede valv.scar./exh.valve seat	-	1	1
C 57+	4845.241 194	guida valv.scar./exh.valve guide	1	-	-
	4845.219 196	guida valv.scar./exh.valve guide	-	1	1
C 58	9652.148 194	valvola aspirazione/inlet valve	1	-	-
	9652.130 196	valvola aspirazione/inlet valve	-	1	1
C 59	9652.149 194	valvola scarico/exhaust valve	1	-	-
	9685.133 196	valvola scarico/exhaust valve	-	1	1
C 60	=9200.695 194	TESTA CON SEDI E GUIDE CYLINDER HEAD WITH SEATS AND GUIDES (Pos. 53-54-56-57-60)	1	-	-
C 61	=8180.201 194	SERIE GUARNIZIONI/GASKET SET	1	-	-
	=8180.179 196	SERIE GUARNIZIONI/GASKET SET	-	1	-
	=8180.199 197	SERIE GUARNIZIONI/GASKET SET (Pos. A 18-A 19-A 26-C 41-C 52-C 55-D 10-D 78- E 25)	-	-	1
C 62	ex > 9032.036 196 A	-> da/from s.No. -> CT 150007 -> tappo olio/filler oil cap	v	v	v
C 63	ex > 1200.082 9 A	-> da/from s.No. -> CT 150007 -> anello OR 3106/O ring	1	1	1
			-	v	v
			-	1	1
D 1	3200.002 9	dado/nut M 6	1	1	1
D 2+	7625.007 9	rondella/washer d.6	1	1	1

Motore/Engine 15LD 225
 Motore/Engine 15LD 315
 Motore/Engine 15LD 350



15LD 225 - 15LD 315 - 15LD 350
vedi Tavola Ric./see Parts Table 1.5302.498

Pos.	Matricola/Part No.	Note/Remarks	15LD 225	15LD 315	15LD 350
D 3+	vedi/see Pos. 9			
D 4+	1200.041 9	anello OR/O ring 103/2018	1	1	1
D 5	9730.012 9	vite/screw M 6 X 20	-	4	4
D 6	3240.009 9	dado/nut M 6	-	2	2
D 7	9180.011 70	terminale/cable-end	-	2	2
D 8	ex 8510.134 - - - - -	sostituito da/superseded by - - - - -	-	v	v
	-> 8510.143 196 A	squadretta/bracket	-	1	1
D 9	=2750.312 196	COPERCHIO ACCEL. E STOP COMPLETO ACCEL.- STOP GOVERNOR COVER ASS.Y (Pos. 3-4-9-13-14-15-16-17-21-22- 23-27-29-29-30-31-32-10)	-	1	1
	=2750.332 196	COPERCHIO ACCEL. E STOP per minivett. ACCEL.- STOP GOV.COVER for microcar (Pos. 3-4-9-14-15-16-17-21-22-23- 27-28-29-30-31-39-40-49-50-51-52- 53-54-55)	-	1	1
D 10	4431.143 196	guarnizione/gasket	-	1	1
D 11	3240.063 9	dado/nut M 10	1	1	1
D 12	8576.072 196	supplemento/extra fuel device	1	1	1
D 13+	6760.047 9	prigioniero/stud M 6 X 16	1	1	1
D 14+	1200.041 9	anello OR/O ring 103/2018	1	1	1
D 15+	7625.105 9	rondella/washer d.8,2	1	1	1
D 16+	1240.002 9	anello seeger/circlip diam.8	1	1	1
D 17+	vedi/see Pos. 9/41/60			
D 18	ex 8430.074 9	B -> fino a/until -> CT 150006	-	v	v
D 19	ex 5200.873 196 (npd)->	A -> da/from s.No. -> CT 150006 ->	-	v	v
	-> 5200.954 196	leva regolatore/governor lever	-	1	1
D 20	5801.534 196	molla supplemento/extra fuel spring	-	1	1
D 21+	vedi/see Pos. 9/41/60			
D 22+	3240.008 9	dado/nut M 6	1	1	1
D 23+	vedi/see Pos. 9			
D 24	ex 7625.274 196	non più montata/no longer fitted			
D 25	3240.153 9	dado/nut M 6	2	2	2
D 26	1760.027 9	bullone/bolt M 6 X 40 (max.)	1	1	1
D 27+	7625.105 9	rondella/washer d.8,2	1	1	1
D 28+	1240.002 9	anello seeger/circlip diam.8	1	1	1
D 29+	vedi/see Pos. 9/41/60			
D 30+	vedi/see Pos. 9/41/60			
D 31+	3240.008 9	dado/nut M 6	1	1	1
D 32	5200.871 196	leva regol./governor lever	-	1	1
D 33	5655.220 196	molla reg./gover.spring 3600 R.P.M.	1	1	1
	5655.245 196	molla reg./gover.spring 1500 R.P.M.	-	1	1
	5655.191 196	molla reg./gover.spring 3000 R.P.M.	1	1	1
D 34	5200.872 196	leva comando portata/lever	-	1	1
D 35	5600.040 196	molla/spring	-	1	1
D 36	ex 5200.870 196 (npd)->	A -> da/from s.No. -> CT 150006 ->	-	v	v
	-> 5200.954 196	leva regolatore interna/control lever	-	1	1
D 37	1760.029 9	bullone/bolt M 6 X 40 (min.)	1	1	1
D 38	5830.119 9	morsetto/nut	-	1	1
D 39+	7565.004 9	rondella/washer d.6	1	1	1
D 40+	7565.004 9	rondella/washer d.6	1	1	1
D 41	=2750.327 196	COMANDO A DISTANZA COMPLETO REMOTE CONTROL ASS.Y (Pos. 4-14-15-16-17-21-22-27-28-29- 30-31-39-40-41-42-43)	-	1	1
D 42+	vedi/see Pos. 41			
D 43+	vedi/see Pos. 41			
D 44	9790.030 9	vite/screw M 6 X 30	-	1	1

Motore/Engine 15LD 225
Motore/Engine 15LD 315
Motore/Engine 15LD 350



15LD 225 - 15LD 315 - 15LD 350
vedi Tavola Ric./see Parts Table 1.5302.498

Pos.	Matricola/Part No.	Note/Remarks	15LD 225	15LD 315	15LD 350
D 45	7565.004 9	rondella/washer d.6	-	1	1
D 46	7626.047 9	rondella/washer d.6	-	1	1
D 47	6927.373 196	protezione/guard	-	1	1
D 48	5655.230 196	molla ritorno leva stop/spring	1	1	1
D 49+	1760.034 9	bullone/bolt M 6 X 25	-	1	1
D 50+	3203.050 9	dado autoblocc./nut M 6	-	1	1
D 51+	5715.060 9	molla a tazza/washer	-	1	1
D 52+	7625.274 196	rondella tenuta/washer	-	1	1
D 53+	5655.244 196	molla registr.minimo/minimum spring	-	1	1
D 54+	3240.008 9	dado/nut M 6	-	2	2
D 55+	vedi/see Pos. 2			
D 56	ex -> 3240.008 9 A	-> da/from s.No. -> CT 150006 -> dado/nut M 6	1	1	1
D 57	ex -> 7565.004 9 A	-> da/from s.No. -> CT 150006 -> rondella/washer d.6	1	1	1
D 58+	vedi/see Pos. 60			
D 59	9730.337 194	vite/screw M 6 X 16	4	-	-
D 60	=2750.348 194	COPERCHIO ACCEL. E STOP COMPLETO ACCEL.- STOP GOVERNOR COVER ASS.Y (Pos. 4-9-13-14-15-16-17-22-27-28- 29-31-39-40-58-60-62-63-66)	1	-	-
D 61	4431.157 194	guarnizione coperchio/gasket	1	-	-
D 62+	vedi/see Pos. 60			
D 63+	vedi/see Pos. 60			
D 64	5200.373 194	leva regolatore/control lever	1	-	-
D 65	5801.581 194	molla supplemento/extra fuel spring	1	-	-
D 66+	vedi/see Pos. 60			
D 67	5200.977 194	leva regol./governor lever	1	-	-
D 68	1585.204 194	boccola/sleeve	1	-	-
D 69	5200.973 194	leva comando portata/lever	1	-	-
D 70	5600.042 194	molla/spring	1	-	-
D 71	5200.975 194	leva regolatore interna/control lever	1	-	-
D 72	1400.233 196	asta livello/oil dipstick	-	1	1
D 73	9732.084 9	vite/screw M 6 X 12	-	1	1
D 74	7565.004 9	rondella/washer d.6	-	1	1
D 75	1400.285 194	asta livello/oil dipstick	1	-	-
D 76	1400.232 196	asta livello/oil dipstick	-	1	1
D 76	9730.010 9	vite/screw M 6 X 16	2	2	2
D 77	=9220.113 194	TESTINA FILTRO/OIL FILTER HEAD	1	-	-
D 77	ex 9220.089 196	E -> da/from s.No. 3882887 -> CT 150003 ->	-	v	v
D 77	ex 9220.090 196	E -> da/from s.No. 3882887 -> CT 150003 ->	-	v	v
D 77	->=9220.107 196	A TESTINA FILTRO/OIL FILTER HEAD (Pos. 77-81-82)	-	1	1
D 77	9220.099 196	per ft.olio a dist./for remote oil f.	-	1	1
D 78	4400.072 194	guarnizione/gasket	1	-	-
D 78	1200.234 9	anello OR/O ring 53,70 X 1,78	-	1	1
D 78	4400.071 196	per ft.olio a dist./for remote oil f.	-	1	1
D 79	2280.061 9	chiavetta/key 3X3,7X10	1	1	1
D 80	6605.090 196	pompa olio/oil pump	1	1	1
D 81+	8965.048 9	tappo/plug M 10	1	1	1
D 82+	4670.059 9	guarniz.rame/copper gasket d.10	1	1	1
D 83	2175.171 194	cartuccia/oil filter element	1	-	-
D 83	ex 2175.129 - - - - -	sostituito da/superseded by - - - - -	-	v	v
D 83	-> 2175.155 196 I	cartuccia/oil filter element	-	1	1
D 84	9330.078 196	tubo/dipstick tube	-	1	1
D 85	1200.034 9	anello OR/O ring	-	1	1
D 86	1111.165 196	alb. pompa olio/oil pump shaft	1	1	1

Motore/Engine 15LD 225
 Motore/Engine 15LD 315
 Motore/Engine 15LD 350



15LD 225 - 15LD 315 - 15LD 350
vedi Tavola Ric./see Parts Table 1.5302.498

Pos.	Matricola/Part No.	Note/Remarks	15LD 225	15LD 315	15LD 350
D 87	9730.012	9 vite/screw M 6 X 20	2	2	2
D 88	8836.210	196 supporto/oil pump support	1	1	1
D 89	7770.172	196 rullino/roller 3X15,8	1	1	1
D 90	2765.000	2 vite/screw M 8 X 10	1	-	-
D 91	8245.003	9 sfera/ball d.4,8 3/16"	1	-	-
D 92	9015.008	196 tappo/pressure valve plug	-	1	1
D 93	6495.056	196 pistoncino/drive rod	-	1	1
D 94	5625.008	107 molla valvola/press.valve spring	-	1	1
D 95	8510.152	194 squadretta/bracket	1	-	-
D 96	6927.424	194 protezione/guard	1	-	-
D 97+	vedi/see Pos. 99			
D 98+	vedi/see Pos. 99			
D 99	=2750.359	194 COPERCHIO ACCEL. E STOP COMPLETO ACCEL.- STOP GOVERNOR COVER ASS.Y (Pos. 4-9-13-14-15-16-17-22-27-28- 29-31-39-40-62-63-66-97-98-99)	1	-	-
D100	5625.021	194 molla valvola/press.valve spring	1	-	-
E 1	8103.269	196 serbatoio/fuel tank	-	1	1
E 2	9043.079	183 tappo serb./fuel tank cap std.	1	1	1
	9043.089	196 tappo serb./fuel tank cap spec.Weber	-	1	1
E 3	ex 3203.047	- - - - - sostituito da/superseded by - - - - -			
	-> 3240.164	9 I dado/nut M 8	2	2	2
E 4	7701.154	9 rondella gomma/rubber washer	2	2	2
E 5	3527.384	196 distanziale/spacer	2	2	2
E 6	7670.118	196 rondella/washer	2	-	-
	7625.272	196 rondella/washer d.8,2	-	2	2
E 7	7701.154	9 rondella gomma/rubber washer	2	2	2
E 8	9375.846	196 tubo/fuel pipe 5x10 mm.165	-	1	1
E 9	3630.113	9 fascetta/clamp	-	2	2
E 10	9375.847	196 tubo/fuel pipe 5x10 mm. 75	-	1	1
E 11	3630.050	9 fascetta/clamp	-	1	1
E 12	3902.310	196 flangia/injector flange	-	1	1
E 13	3203.050	9 dado/nut M 6	-	2	2
E 14	6370.512	196 piastra/injector plate	-	1	1
E 15	5010.040	196 iniettore/injector 15LD 315	-	1	-
	5010.043	197 iniettore/injector 15LD 350	-	-	1
E 16	2527.082	196 connettore/pipe fitting	-	1	1
E 17	7270.108	9 raccordo/banjo union d.6	-	1	1
E 18	9375.807	196 tubo alta pressione/high press.pipe	-	1	1
E 19	4670.001	9 guarniz.rame/copper gasket d.6	-	2	2
E 20	1901.146	9 bullone raccordo/union bolt M 6	-	1	1
E 21	6531.435	196 polverizzatore/nozzle 15LD 315	-	1	-
	6531.447	197 polverizzatore/nozzle 15LD 350	-	-	1
E 22	4670.099	550 guarnizione iniettore/gasket	1	1	1
E 23	9730.012	9 vite/screw M 6 X 20	2	2	2
E 24	6590.324	194 pompa iniez./injection pump std.	1	-	-
	6590.259	196 pompa iniez./injection pump std.	-	1	1
	6590.281	196 per minivetture/special for minicar	1	1	1
E 25	4580.180	194 guarn.pomp.inez./gasket	1	-	-
	4580.160	196 guarn.pomp.inez./gasket 0,05	-	1	1
	4580.161	196 guarn.pomp.inez./gasket 0,10	-	1	1
	4580.162	196 guarn.pomp.inez./gasket 0,30	-	1	1
	4580.163	196 guarn.pomp.inez./gasket 0,50	-	1	1
E 26	9730.319	9 vite/screw M 6 X 12	-	1	1

Motore/Engine 15LD 225
 Motore/Engine 15LD 315
 Motore/Engine 15LD 350



15LD 225 - 15LD 315 - 15LD 350
vedi Tavola Ric./see Parts Table 1.5302.498

Pos.	Matricola/Part No.	Note/Remarks	15LD 225	15LD 315	15LD 350
E 27	3617.197 196	fascetta/fuel filter clamp	-	1	1
E 28	ex 3730.088 - - - - -	sostituito da/superseded by - - - - - >	-	v	-
	-> 3730.096 196 I	filtro comb./fuel filter	-	1	1
E 29	7670.118 196	rondella/washer	2	-	-
	7626.047 9	rondella/washer d.6,2	-	2	2
	7625.272 196	rondella/washer d.8,2	-	2	2
E 30	7701.154 9	rondella gomma/rubber washer	2	2	2
E 31	3527.384 196	distanziale/spacer	-	1	1
E 32	9375.842 196	tubo/fuel pipe 5x10 mm. 95	-	1	1
E 33	3203.050 9	dado/nut M 6	-	2	2
	3240.164 9	dado/nut M 8	2	2	2
E 34	7701.154 9	rondella gomma/rubber washer	2	2	2
E 35	9602.132 196	tubetto distanziale/spacer	-	1	1
E 36	9375.844 196	tubo comb./fuel pipe 5x10 mm. 85	-	1	1
E 37	ex 9375.883 - - - - -	sostituito da/superseded by - - - - - >	-	v	-
	-> 9375.845 196 I	tubo comb./fuel pipe 8x6 mm 155	-	1	1
E 38	9375.891 196	tubo comb./fuel pipe 9,5x4,5 mm.80	-	1	1
E 40	6000.072 104	registro/adj.spacer (lilla/viol) 4,00	1	-	-
	6000.073 104	registro/adj.spacer (bianc/white) 4,10	1	-	-
	6000.074 104	registro/adj.spacer (giall/yello) 4,20	1	-	-
	6000.075 104	registro/adj.spacer (aranc/orang) 4,30	1	-	-
	6000.076 104	registro/adj.spacer (azzur/l.blu) 4,40	1	-	-
	6000.077 104	registro/adj.spacer (verde/green) 4,50	1	-	-
	6000.078 104	registro/adj.spacer (blu/blue) 4,60	1	-	-
	6000.079 104	registro/adj.spacer (rosso/red) 4,70	1	-	-
	ex 6000.050 - - - - -	sostituito da/superseded by - - - - - >	-	v	-
	-> 6000.072 104 I	pastiglia/sleeve	-	1	1
E 41	7215.097 196	punteria/push rod	1	1	1
E 42	7625.092 9	rondella/washer d.6,5	1	1	1
E 43	9865.221 196	vite/screw M 6 X 1	1	1	1
E 44	ex 3527.403 - - - - -	sostituito da/superseded by - - - - - >	-	v	-
	-> 3527.419 196 I	distanziale/spacer	2	1	1
E 45	3630.160 9	fascetta/clamp d.10,5	-	1	1
E 46	3630.159 9	fascetta/clamp d.10-12,5	-	1	1
E 47	3630.159 9	fascetta/clamp d.10-12,5	-	1	1
E 48	3630.113 9	fascetta/clamp	1	1	1
E 49	1760.001 9	bullone/bolt M 6 X 10	-	2	2
E 50	1901.037 9	bullone racc./union bolt	-	1	1
E 51	1901.037 9	bullone racc./union bolt	-	1	1
E 52	3240.008 9	dado/nut M 6	-	2	2
E 53	3587.144 196	elettrovalvola/electro-valve	-	1	1
E 54	4670.057 9	guarniz.rame/copper gasket	-	2	2
E 55	4670.057 9	guarniz.rame/copper gasket	-	2	2
E 56	7555.004 9	rondella/washer d.6	-	2	2
E 57	8510.145 196	squadretta/bracket	-	1	1
E 58	8836.258 196	supporto/support	-	1	1
E 59	3630.113 9	fascetta/clamp	-	4	4
E 60	9375.919 196	tubo comb./fuel hose mm 225	-	1	1
E 61	9375.920 196	tubo comb./fuel hose mm 210	-	1	1
E 62	7270.100 9	raccordo/banjo union	-	1	1
E 63	7270.100 9	raccordo/banjo union	-	1	1
E 64	7755.106 196	rubinetto/shut off valve	-	1	1
E 65	1901.030 9	bullone raccordo/union bolt M 10	1	1	1
E 66	1570.045 107	bocchettone/filler cap M 14	1	1	1
E 67	3587.119 107	elettrovalvola/electrovalve	1	1	1
E 68	=3730.073 107	FILTRO COMBUSTIBILE/FUEL FILTER (Pos. 68-71)	1	1	1
E 69	4670.059 9	guarnizione rame/copper gasket	2	2	2
E 70	4670.061 9	guarnizione rame/copper gasket	2	2	2
E 71+	2175.045 2830	cartuccia comb./fuel filter elem.	1	1	1

Motore/Engine 15LD 225
 Motore/Engine 15LD 315
 Motore/Engine 15LD 350



15LD 225 - 15LD 315 - 15LD 350
vedi Tavola Ric./see Parts Table 1.5302.498

Pos.	Matricola/Part No.	Note/Remarks	15LD 225	15LD 315	15LD 350	
E 72	4670.061	9	guarnizione rame/copper gasket	2	2	2
E 73	1901.032	9	bullone raccordo/union bolt M 14	1	1	1
E 74	9375.903	196	tubo el.valv.-pm iniez./fuel hose	-	1	1
E 75	9375.904	196	tubo a el.valv./fuel hose	-	1	1
E 76	9672.138	194	valvol.mand./del.valve (6590.324)	1	-	-
	9672.116	196	valvol.mand./del.valve (6590.259/281)	1	1	1
E 77	3630.160	9	fascetta/clamp	-	2	2
E 78	9375.977	194	tubo comb.completo/fuel hose ass.y	1	-	-
E 79	9375.974	194	tubo disaerazione/bleeding pipe mm 80	1	-	-
E 80	8103.300	194	serbatoio combust./fuel tank	1	-	-
E 81	9730.015	9	vite/screw M 6 X 30	1	-	-
E 82	7555.027	9	rondella/washer d.6	1	-	-
E 83	8545.610	194	staffa iniettore/bracket	1	-	-
E 84	7270.196	194	raccordo iniettore/connection	1	-	-
E 85	4670.001	9	guarniz.rame/copper gasket d.6	1	-	-
E 86	2110.058	194	canotto cartuccia/cartridge guide	1	-	-
E 87	5010.049	194	iniettore/injector 15LD 225	1	-	-
E 88	6531.459	194	polverizzatore/nozzle 15LD 225	1	-	-
E 89	9375.933	194	tubo alta pressione/high press.pipe	1	-	-
E 90	1160.062	194	anello a filo/safety ring	1	-	-
E 91	2175.162	194	cartuccia combust./fuel cartridge	1	-	-
E 92	3240.132	9	dado/nut M 10	1	-	-
E 93	7625.130	105	rondella/washer	1	-	-
E 94	4580.076	183	guarnizione tenuta/seal gasket	1	-	-
E 95	7458.008	194	riduzione per connettore/reduction	1	-	-
E 96	7270.191	194	raccordo per serbatoio/connection	1	-	-
E 97	7270.138	9	raccordo orient./banjo union d.10	1	1	1
E 98	1901.030	9	bullone raccordo/union bolt M 10	2	2	2
E 99	9732.092	9	vite/screw M 8 X 18	2	2	2
EL00	6585.066	104	pompa alim./fuel feed pump	1	1	1
E101	1200.087	9	anello OR 3150/O ring	1	1	1
E102	4670.059	9	guarnizione rame/copper gasket d.10	2	2	2
E103	4670.059	9	guarnizione rame/copper gasket d.10	2	2	2
E104	7200.193	194	puntalino pompa alim./feed pump rod	1	-	-
	7200.165	196	puntalino pompa alim./feed pump rod	-	1	1
E105	3587.138	196	elettrovalvola/electro-valve	1	1	1
E106	2527.082	196	connettore/pipe fitting	2	-	-
F 1	5066.276	194	lamiera conv.post./rear panel	1	-	-
	5066.250	196	lamiera conv.post./rear panel	-	1	1
F 2	9790.037	9	vite/screw M 6 X 8	2	2	2
F 3	5066.275	194	lamiera conv.lat./side panel	1	-	-
	5066.249	196	lamiera conv.lat./side panel	-	1	1
F 4	9790.037	9	vite/screw M 6 X 8	1	1	1
F 5	9732.084	9	vite/screw M 6 X 12	5	5	5
F 6	2569.654	194	convogliatore/shroud	1	-	-
	2569.498	196	convogliatore/shroud	-	1	1
F 7	2501.130	196	colonna/hollowstud	-	4	4
F 8	7986.028	196	scudo insonorizz./denoised guard	-	1	1
F 9	7625.007	9	rondella/washer d.6	-	4	4
F 10	9732.091	9	vite/screw M 6 X 12	-	4	4
F 11	7625.007	9	rondella/washer d.6	-	4	4
F 12	ex 3855.130	- (npd) - -	vedi/see Pos. F 13	-	v	v
F 13	7951.173	196	scatola senza autoavvolg./house	1	1	1
F 14+	4904.038	196	impugnatura completa/handgrip	1	1	1
F 15+		vedi/see Pos. 22			
F 16+	5025.094	196	dente/tooth	1	1	1
F 17+	5660.066	196	molla/spring	1	1	1
Motore/Engine	15LD 225					
Motore/Engine	15LD 315					
Motore/Engine	15LD 350					



15LD 225 - 15LD 315 - 15LD 350
vedi Tavola Ric./see Parts Table 1.5302.498

Pos.	Matricola/Part No.	Note/Remarks	15LD 225	15LD 315	15LD 350
F 18+	5590.026 196	molla/spring	1	1	1
F 19+	vedi/see Pos. 22			
F 20+	1165.006 9	anello tenuta/circlip	1	1	1
F 21	6961.108 194	puleggia/pulley	1	-	-
'	6961.104 196	puleggia/pulley	-	1	1
F 22	=1471.089 196	AVVIATORE AUTOAVV./REWIND STARTER	1	1	1
'	=1471.091 196	per mot.1500 g/for engine 1500 RPM (Pos. 14-15-16-17-18-19-20-22-25-26-27-28)	-	1	1
F 23	7625.007 9	rondella/washer d.6	4	4	4
F 24	9730.309 9	vite/screw M 6 X 8	4	4	4
F 25+	5801.539 196	molla/spring	1	1	1
F 26+	7100.371 196	puleggia/pulley	1	1	1
F 27+	5025.094 196	dente/tooth	1	1	1
F 28+	vedi/see Pos. 22			
F 29	9732.064 9	vite/screw M 8 X 30	3	3	3
F 30	9730.012 9	vite/screw M 6 X 20	3	3	3
F 31	7565.007 9	rondella/washer d.8	3	3	3
F 32	ex	-> da/from s.No. 3582963 -> CT 150001 ->		v	
'	-> 7362.255 1830 A	regol.tens./voltage regul.12 V 12 A	1	1	1
'	7362.298 107	regol.tens./voltage regul.12 V 20 A	1	1	1
F 33	2145.014 276	cappuccio/rubber cap	1	1	1
F 34	9732.041 9	vite/screw M 10 X 18	-	2	2
F 35	3800.039 196	flangia/flange	-	1	1
F 36	3440.034 196	dispos.protezione/guard device	-	1	1
F 37	9732.074 9	vite/screw M 8 X 20	-	2	2
F 38	1557.103 107	blocchetto cavi/wire connection	1	1	1
F 39	2185.914 196	cavo collegamento/wire	-	1	1
F 40	7750.109 194	rotore/electrical rotor 12 V 12/20 A	1	-	-
'	ex	-> da/from s.No. 3582963 -> CT 150001 ->		v	
'	-> 2002.019 196 A	rotore/electrical rotor 12 V 12/20 A	-	1	1
F 41	ex 8565.077 107 B	-> da/from s.No. 3582963 -> CT 150001 ->		v	
'	-> 8565.078 196 A	statore/alternator stator 12 V 12 A	1	1	1
'	ex 8565.076 107 B	-> da/from s.No. 3582963 -> CT 150001 ->		v	
'	-> 8565.080 107 A	statore/alternator stator 12 V 20 A	1	1	1
F 42	ex 6745.044 - - -	sostituito da/superseded by - - - ->	-	v	v
'	ex 6745.050 107 B	-> da/from s.No. 3882887 -> CT 150003 ->	-	v	v
'	-> 6745.052 107 A	pressostato/pressure oil switch M 10	1	1	1
F 43	ex 4670.060 9 B	-> da/from s.No. 3882887 -> CT 150003 ->	-	v	v
'	-> 4670.059 9 A	guarn.rame/copper gasket diam.10	-	1	1
F 44	4670.055 9	guarn.rame/copper gasket diam.12,5	-	1	1
F 45	5041.020 276	interruttore/key switch	-	1	1
F 46	7245.359 196	quadretto/electr.panel 12 V	-	1	1
F 47	2185.882 107	prolunga/wire extension	-	1	1
F 48	2185.908 196	cavo per solo spia carica batteria	-	1	1
'	2185.907 196	el.wire for battery light only	-	1	1
'		cavo per spia c.batt.e spia olio	-	1	1
'		el.wire for batt.light and oil warn.	-	1	1
F 49	9730.044 9	vite/screw M 10 X 25	2	2	2
F 50	5840.186 194	motorino avv./starting motor 12 V	1	-	-
'	ex 5840.170 - - (nrd) >	-> da/from s.No. 3582963 -> CT 150001 ->		v	
'	-> 5840.176 196 A	motorino avv./starting motor 12 V	-	1	1
'	5840.178 196	motorino avv./starting motor 24 V	-	1	1
F 51	9195.085 196	termostato/oil thermostat	-	1	1

Motore/Engine 15LD 225
 Motore/Engine 15LD 315
 Motore/Engine 15LD 350



15LD 225 - 15LD 315 - 15LD 350
vedi Tavola Ric./see Parts Table 1.5302.498

Pos. Matricola/Part No. Note/Remarks

15LD 225
15LD 315
15LD 350

TABELLA ALBERI A GOMITO e BLOCCHI MOTORE/CRANKSHAFT and SHORT BLOCK

tipo albero gom. crankshaft type	per motori senza equilibratore for engines without equalizer device				
	15LD 225 alb.gom. crkshaft	15LD 315 15LD 350 alb.gom. crkshaft	bloc.mot sh.block 15LD 225	bloc.mot sh.block 15LD 315	bloc.mot sh.block 15LD 350
conico std conical PTO	1050.986	1050.855	1560.279	1560.275	1560.278
Ext 4 SAE	1050.988	1050.889	-	-	-
Ext 6 SAE	1050.990	1050.891	-	1560.277	-
Ext 3 SAE	1050.992	1050.911	1560.281	-	-
Ext 9 SAE	1050.994	1050.913	-	-	-
Ext a 4	-	1050.915	-	-	-
Ext 7 SAE	-	1050.933	-	-	-
Ext M 8 interc.B & S	-	1050.945	-	-	-

tipo albero gom. crankshaft type	per motori con equilibratore for engines with equalizer device				
	15LD 225 alb.gom. crkshaft	15LD 315 15LD 350 alb.gom. crkshaft	bloc.mot sh.block 15LD 225	bloc.mot sh.block 15LD 315	bloc.mot sh.block 15LD 350
conico std conical PTO	1050.987	1050.856	1560.280	1560.276	-
Ext 4 SAE	1050.989	1050.890	-	-	-
Ext 6 SAE	1050.991	1050.892	-	-	-
Ext 3 SAE	1050.993	1050.912	-	-	-
Ext 9 SAE	1050.995	1050.914	-	-	-
Ext a 4	-	1050.916	-	-	-
Ext 7 SAE	-	-	-	-	-
Ext M 8 interc.B & S	-	-	-	-	-

Motore/Engine 15LD 225
Motore/Engine 15LD 315
Motore/Engine 15LD 350

