

**TAVOLA RICAMBI
TABLEAU PIECES DETACHEES
SPARE PARTS TABLE
ERSATZTEILTAFEL
TABLA DE REPUESTOS
TÁBUA PEÇAS DE TROCA**

**4LD640
4LD705
4LD820**

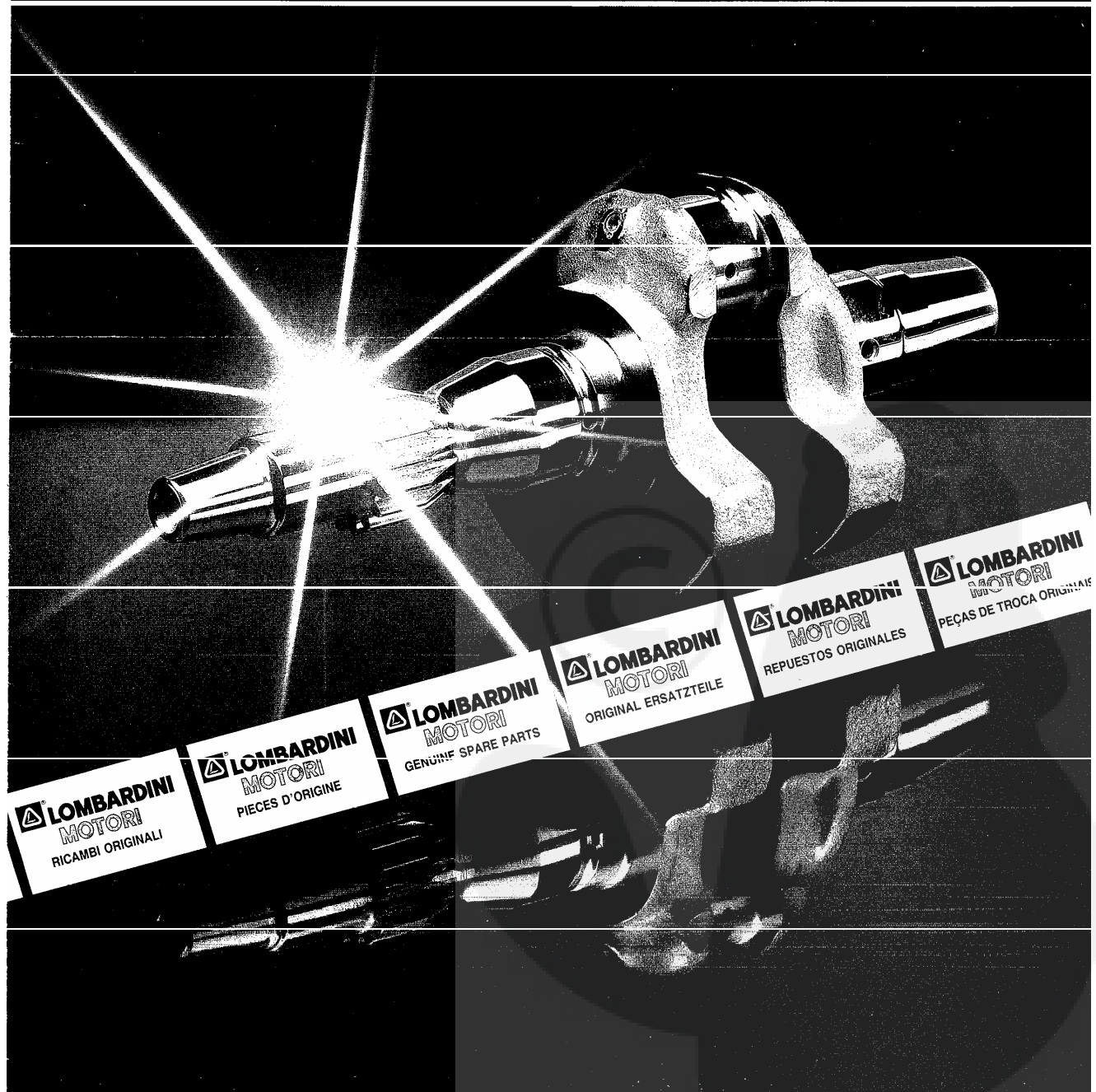

**LOMBARDINI
MOTORI**
RICAMBI ORIGINALI

**LOMBARDINI
MOTORI**
PIECES D'ORIGINE

**LOMBARDINI
MOTORI**
GENUINE SPARE PARTS

**LOMBARDINI
MOTORI**
ORIGINAL ERSATZTEILE

**LOMBARDINI
MOTORI**
REPUESTOS ORIGINALES

**LOMBARDINI
MOTORI**
PEÇAS DE TROCA ORIGINALES

RICAMBI
PIECES
SPARE PARTS
ERSATZTEILE
REPUESTOS
RECAMBIOS

RICAMBI PER MOTORE STANDARD.
PER APPLICAZIONI SPECIALI
CONSULTARE IL CATALOGO PRESSO I
CENTRI ASSISTENZA E RICAMBI.

PIECES POUR DES MOTEURS
STANDARD.
POUR LES ADAPTATIONS CONSULTER
LE CATALOGUE AUPRES DES AGENTS
SERVICE.

SPARE PARTS FOR STANDARD
ENGINE.
FOR SPECIAL APPLICATIONS SEE
MASTER CATALOG AT SERVICE
CENTERS.

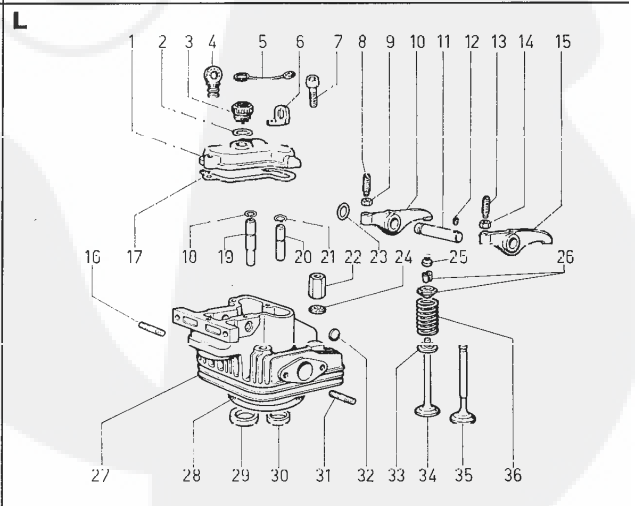
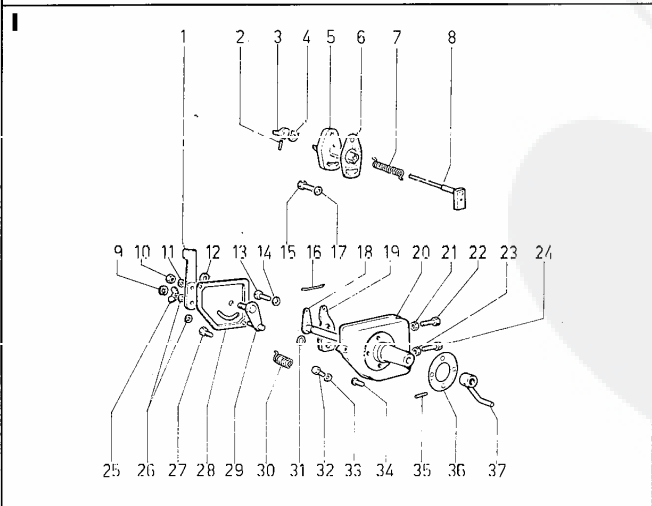
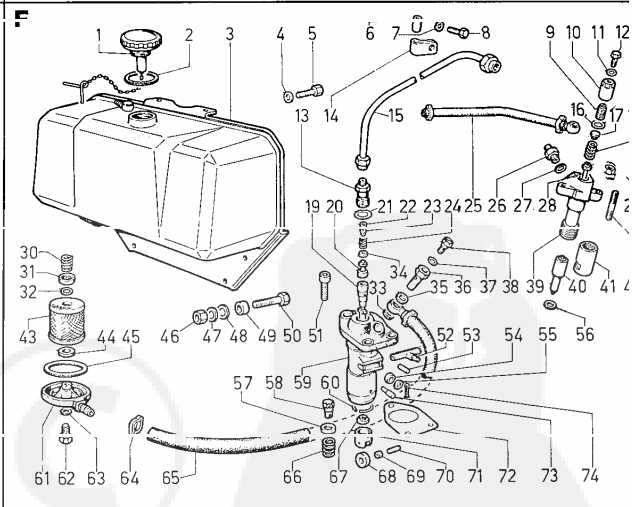
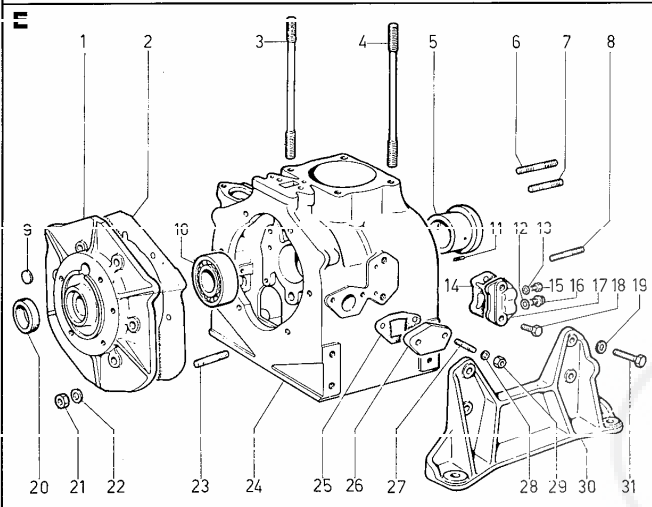
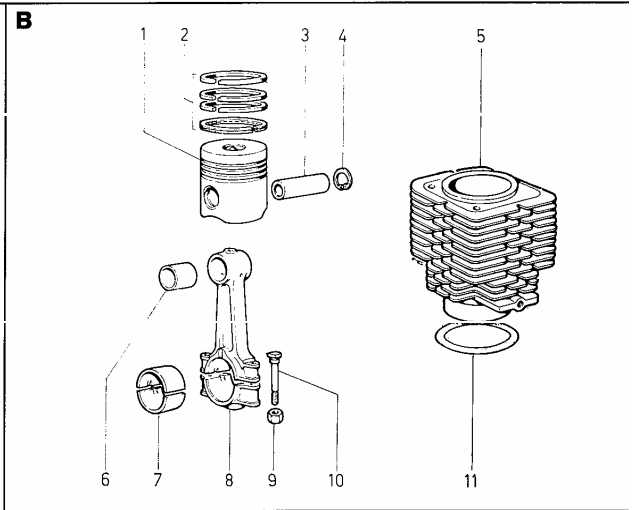
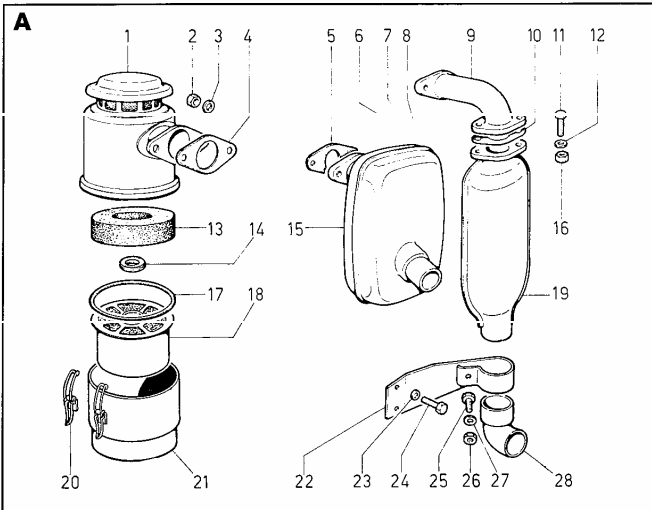

ERSATZTEILE FÜR STANDARD-
MOTOREN.
FÜR SONDERANFERTIGUNGEN SIEHE
ERSATZTEILKATALOG BEI SERVICE
WERKSTÄTTEN.

REPUESTOS PARA MOTORES
STANDARD.
PARA APLICACIONES VEASE
CATALOGO EN LAS ESTACIONES
SERVICE.

PEÇAS DE TROCA PARA MOTOR
STANDARD.
PARA APLICAÇÕES ESPECIAIS
CONSULTAR O CATÁLOGO NOS
CENTROS DE ASSISTÊNCIA E PEÇAS
DE TROCA.

GRUPPO

4

Matricola 1.5302.316

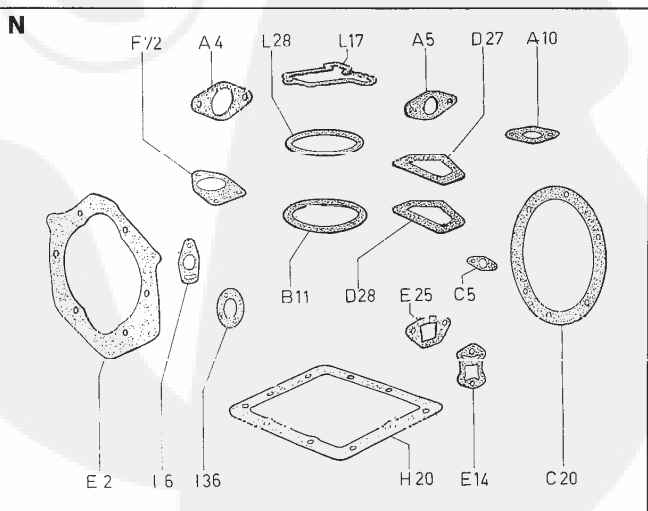
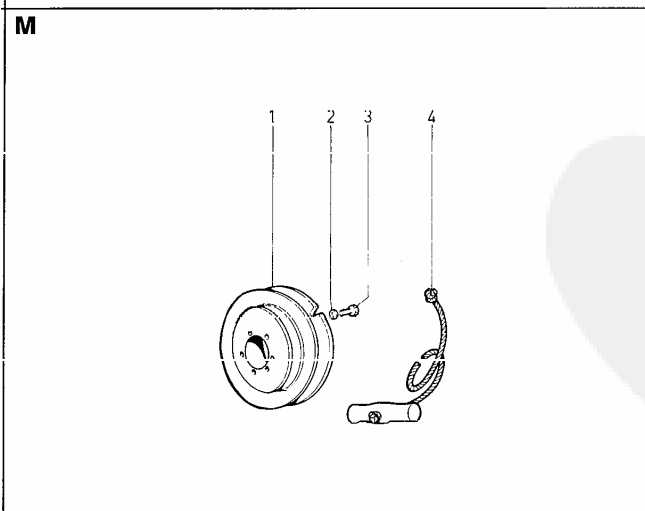
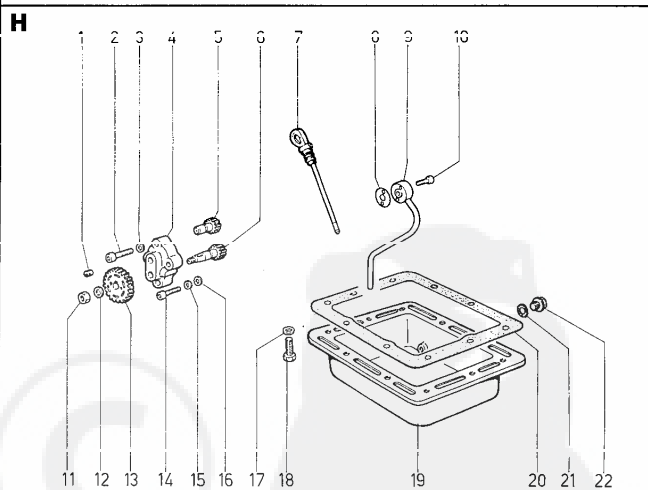
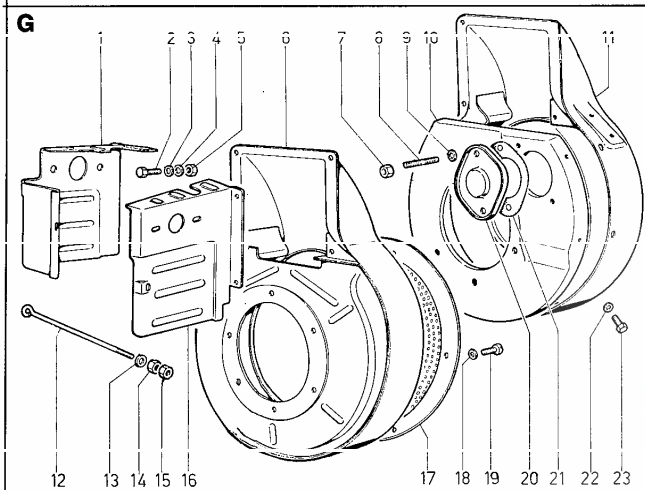
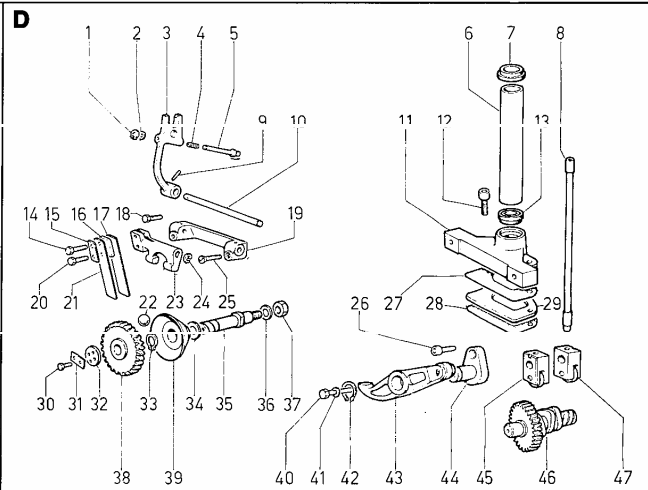
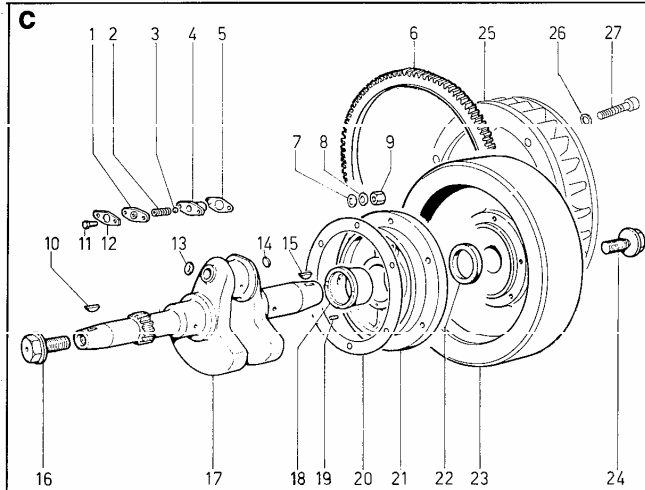

SERVICE



4

Per assistenza e ricambi rivolgersi a stazioni di servizio autorizzate Lombardini. N. tel. su libretto service e su pagine gialle.
 Pour toute exigence de service après-vente et pièces détachées, s'adresser aux Stations de service du réseau Lombardini. N. de téléphone indiqué sur brochure relative au service après-vente et annuaire catégorique.
 For spare parts and after sale assistance contact authorized Lombardini service centers. Tel. No. appears on service booklet and telephone directory.
 Für Service und Ersatzteile bitten wir, sich an autorisierte Werkstätte zu wenden. Telef. Nummer laut unserem Service-Büchlein und Fernsprechbuch.
 Para asistencia y repuestos, dirigirse a las estaciones de servicio autorizadas Lombardini. N. Tel. su libretto service y su hojas amarillas.
 Para assistência e recâmbios dirigir-se às estações de serviço autorizadas Lombardini. Número telefone é sobre a caderneta de serviço e sobre as páginas amarelas.

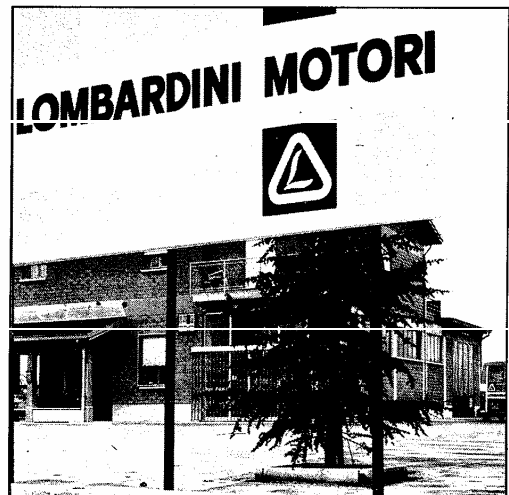
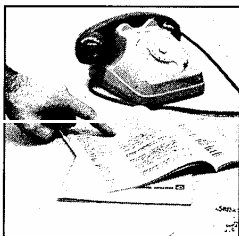
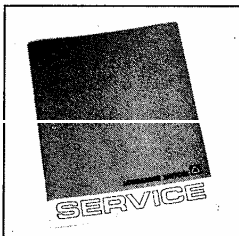

**ORDINI RICAMBI
 COMMANDES PIÈCES
 PART ORDERS
 E-TEIL BESTELLUNGEN
 PEDIDOS DE REPUESTOS
 PEDIDOS RECÂMBIOS**

**TIPO MOTORE
 TYPE DE MOTEUR
 ENGINE TYPE
 MOTORTYP
 TIPO DEL MOTOR
 TIPO DE MOTOR**

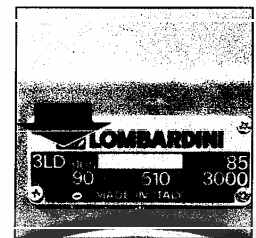
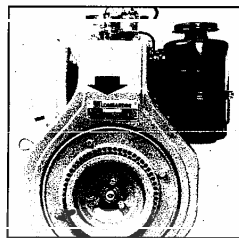

**MATRICOLA
 MATRICULE
 SERIAL NUMBER
 MOTORENNUMMER
 NUMERO DEL MOTOR
 NUMERO DO MOTOR**

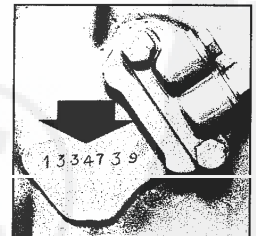
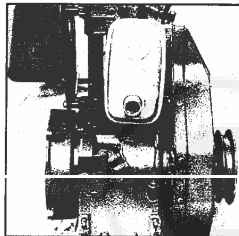
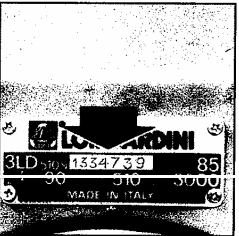
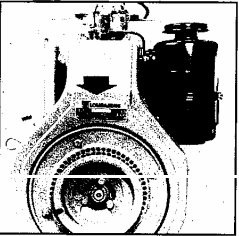

**TIPO DELLA MACCHINA
 TYPE DE MACHINE
 EQUIPMENT TYPE
 MASCHINENTYP
 MODELO DE LA MAQUINA
 TIPO DA MÁQUINA**

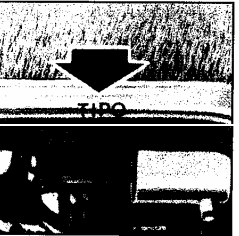
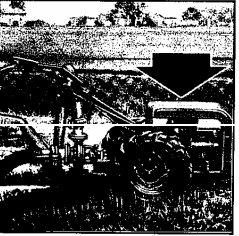

**MATRICOLA del ricambio
 REFERENCE de la pièce
 SPARE PART number
 BESTELLNUMMER des Teiles
 REFERENCIA del repuesto
 REFERÊNCIA do recâmbio**

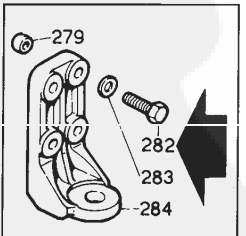
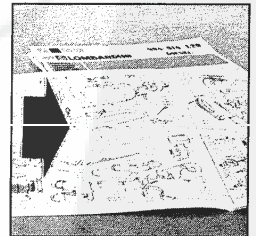

LOMBARDINI

FABBRICA ITALIANA MOTORI S.p.A.
 42100 REGGIO EMILIA, ITALIA - CAS. POST. 105 - Tel. (0522) 58011 - Teleg.: LOMBARMOTOR - Telex: 530003 MOTLOM I

LOMBARDINI USA: 2150 Boggs Road Bldg. 300, Suite 300 - Duluth, GA 30136, USA
 LOMBARDINI FRANCE: Zone Industr. Nord Arnas - Villefranche S/Saône, France
 LOMBARDINI MOTOREN GMBH: Berner Str. 54, 6000 Frankfurt/Main 56, Deutschland
 LOMBARDINI MOTORES: Zona Cova Solera - Rubi/Barcelona, España

Matricola 1:5302:316

Mod. 50539
12-1990
Subject to alteration

Printed in Italy

 LEGENDA TAVOLA RICAMBI MATR.
 SPARE PARTS TABLE P.NO. ... 1.5302.316
 TABLEAU PIECES DETACHEES REF.

 Dicembre/December/Décembre 1990

MOTORI/ENGINES/MOTEURS Gr. 4
 Colonna/Column/Colonne 1 = 4LD 640 Versione/Version std. 710170
 " " 2 = 4LD 705 " " " 710390
 " " 3 = 4LD 820 " " " 710320

Vedi/See/Voir

Libretto Uso e Manutenzione
 Use-Maintenance booklet 1.5302.075
 Livret Emploi-Entretien
 Libretto Service
 Service directory 1.7968.002
 Réseau S.A.V.
 Serie accessori
 Accessory set 283.8140.080
 Jeu accessoires

note/remarks/remarques

- F - alta movimentazione/fast moving part/haut mouvement.
 S - media movimentazione/medium moving part/moyen mouvement.
 D - bassa movimentazione/slow moving part/bas mouvement.
 E - ad esaurimento/exhausting part/piece en epuïsement.
 N - particolare nuovo o fornito su richiesta/
 -new part or part supplied upon request/
 -pièce nouvelle ou fournie sur demande.
 A - valido dal motore.../from eng.S.No.../à partir du moteur...
 (vedi Circolare Tecnica/see Service Letter/voir Circ.Techn.)
 B - valido fino al motore.../up to eng.S.No.../jusqu'au moteur...
 (vedi circolare tecnica/see Service Letter/voir circ.techn.)
 I - intercambiabile/interchangeable
 (vedi Circolare Tecnica/see Service Letter/voir Circ.Techn.)
 V - stock vitale per Officine Service.
 vital stock for Service Dealer.
 stock vital pour Stations Service.
 C - stock vitale per Costruttori, Esportatori, Enti di Stato.
 vital stock for Producers, Exporters, State Companies.
 stock vital pour Constructeurs, Export., Institut.de l'Etat.
 R - stock vitale per Rettifica.
 vital stock for Grinding Workshops.
 stock vital pour Usines de Rectification.
 10/50/2-g ta minima fornibile/min supplied q.ty/q.te min.fournie.
 = gruppo completo/assembly/groupe complet.
 + componente del gruppo/assembly component/composant du groupe.

 Serie guarnizioni/Gasket set 272.8180.024 4LD 640
 279.8180.027 4LD 705
 291.8180.038 4LD 820

Tipo motore/Engine type Blocco motore/Short block
 4LD 640 Industr. 2720.1560.033
 4LD 705 Industr. 2790.1560.016
 4LD 820 Industr. 2910.1560.049

TECO/ATL/Assistenza Tecnica Lombardini/Dicembre 1990
 Descrizioni non impegnative/Subject to modifications



ASPIRAZIONE E SCARICO/INTAKE AND EXHAUST

Pos.	Matricola/Part No.	Note/Remarks	Q.ty/Eng.
A 1	=3700.139 272 FVIC	FILTRO ARIA/AIR CLEANER	1 1
"	=3700.141 291 FVIC	FILTRO ARIA/AIR CLEANER (Pos. 1-13-14-17-18-20-21)	1
A 2	3240.037 9 F 10	dado/nut	2 2 2
A 3	7555.008 9 FV C 10	rondella/washer	2 2 2
A 4	4501.003 710 FV C 50	guarnizione/gasket	2 2 2
A 5	4500.007 710 FV C 10	guarnizione/gasket	2 2 2
A 6	7625.019 9 S 10	rondella/washer	2 2 2
A 7	7565.011 9 F C 10	rondella/washer	2 2 2
A 8	3240.053 9 FV C 10	dado/nut	2 2 2
A 9	2941.002 2790 F C C	curva/elbow	1 1 1
A 10	4500.079 276 FV C 10	guarnizione/gasket	1 1 1
A 11	1770.006 9 S 10	bullone/bolt M 8 X 1,25 X 25	2 2 2
A 12	7565.007 9 F C 10	rondella/washer	1 1 1
A 13+	5496.110 292 SVAC	massa filtrante/upper filtering elem.	1 1 1
A 14+	1261.073 292 DVAC	anello tenuta/seal ring diam.= 62,5	1 1 1
A 15	5460.090 270 F C C	marmitta/muffler	1 1 2
A 16	3240.032 9 FV C 10	dado/nut	1 1 1
A 17+	4776.032 291 FV C 10	guarnizione/gasket	1 1 1
A 18+	5496.111 292 FVIC	massa filtrante/filtering element	1 1 1
"	5496.118 291 FVIC	massa filtrante/filtering element	1 1 1
A 19	5461.047 2830 F C C	marmitta/muffler	2 2 2
A 20+	4115.048 276 F C 10	gancio/hook	1 1 1
A 21+	vedi/see Pos. 1 ...	1 1 1
A 22	8545.040 2790 D	staffa/brace	1 1 1
A 23	7625.020 9 D C 10	rondella/washer	1 1 1
A 24	1780.007 9 S 10	bullone/bolt M 10 X 1,5 X 35	1 1 1
A 25	1780.031 9 FV 10	bullone/bolt M 10 X 1,5 X 25	1 1 1
A 26	3240.033 9 FV 10	dado/nut	1 1 1
A 27	7565.011 9 F C 10	rondella/washer	1 1 1
A 28	9170.028 2910 F C	terminale/muffler end	1

Motore/Engine	4LD 640	Versione/Version	710170
"	4LD 705	"	710390
"	4LD 820	"	710320
"	"	"	"

LOMBARDINI MOTORI F.I.M. S.p.a.



CILINDRO, BIELLA E PISTONE/CYLINDER, CONNECTING ROD AND PISTON SET

Pos.	Matricola/Part No.	Note/Remarks	Q.ty/Eng.
B 1	=6500.919 272 FVAC	PISTONE COMPLETO/PISTON SET std.	1
"	=6500.920 272 F ACR	" " "+0,50	1
"	=6500.921 272 F ACR	" " "+1,00	1
"	=6500.922 279 FVAC	" " std.	1
"	=6500.923 279 F ACR	" " "+0,50	1
"	=6500.924 279 F ACR	" " "+1,00	1
"	=6500.925 291 FVAC	" " std.	1
"	=6500.926 291 F ACR	" " "+0,50	1
"	=6500.927 291 F ACR	" " "+1,00	1
(Pos. 1-2-3-4)			
B 2+	8210.052 276 FV C	serie segm./ring set std.	1
"	8210.053 276 F CR	" " "+0,50	1
"	8210.054 276 F CR	" " "+1,00	1
"	8210.049 279 FV C	" " std.	1
"	8210.050 279 F CR	" " "+0,50	1
"	8210.051 279 F CR	" " "+1,00	1
"	8210.058 291 FV C	" " std.	1
"	8210.059 291 F CR	" " "+0,50	1
"	8210.060 291 F CR	" " "+1,00	1
B 3+	8480.010 272 F C	spinotto/gudgeon pin	1
"	8480.021 279 S C	" "	1
"	8480.082 291 D AC	" "	1
B 4+	1240.026 9 FV C 10	anello seeger/snap ring	2
B 5	2380.010 272 FV C	cilindro/cylinder	1
"	2380.055 279 FV C	" "	1
"	2380.082 291 FV C	" "	1
B 6+	1630.006 270 FV CR10	bronz.piede biella/small end bearing	1
B 7	1640.024 262 FV C	br.biella/bearing std.	1
"	1640.025 262 FV CR10	" " -0,25	1
"	1640.026 262 FV CR10	" " -0,50	1
"	1640.045 291 FV C	" " std.	1
"	1640.048 291 F CR	" " -0,25	1
"	1640.049 291 F CR	" " -0,50	1
B 8	=1526.002 270 F C	BIELLA COMPLETA/CONNECTING ROD ASS.Y (Pos. 6-8-9-10)	1
B 9+	3203.034 9 FVIC 10	dado/nut	2
B 10+	1860.007 270 FV C 10	bullone/bolt	2
B 11	4410.061 272 D A 50	guarnizione/gasket	1
"	4410.062 279 D A 50	" "	1
"	4410.063 291 D A 50	" "	1

Motore/Engine 4LD 640 Versione/Version 710170
 " " 4LD 705 " " 710390
 " " 4LD 820 " " 710320



ALBERO A GOMITO, SUPPORTO F VOLANO/CRANKSHAFT, FLYWH.SIDE SUPPORT AND FLYWHEEL

Pos.	Matricola/Part No.	Note/Remarks	Q.ty/Eng.
C 1+	vedi/see Pos. 4 ...	
C 2+	vedi/see Pos. 4 ...	
C 3+	8245.005 9 D C 10	sfera/ball	1 1 1
C 4	=9680.010 273 FV C	VALVOLA DI PRESSIONE/PRESSION VALVE (Pos. 1-2-3-4-5-11-12)	1 1 1
C 5+	4760.007 271 DV C 10	quarnizione/gasket	1 1 1
C 6+	2816.011 270 F C	corona avviamento/crown gear	1 1 1
C 7	7565.011 9 F C 10	rondella/washer	6 6 6
C 8	7625.019 9 S 10	rondella/washer	6 6 6
C 9	3240.033 9 FV 10	dado/nut	6 6 6
C 10+	2280.049 9 FV 10	chiavetta/key	1 1 1
C 11+	1760.003 9 F 10	bullone/bolt M 6 X 1 X 12	2 2 2
C 12+	5110.084 271 D C 10	lamierino/tabwasher	1 1 1
C 13+	8990.019 9 S C 10	tappo/plug	1 1 1
C 14+	8990.002 9 F AC 10	tappo/plug	1 1 1
C 15+	2280.056 9 FV C 10	chiavetta/key	1 1 1
C 16	1862.012 291 S C	bullone/bolt	1 1 1
C 17	=1051.091 272 F IC	ALBERO A GOMITO/CRANKSHAFT	1 1 1
"	=1051.092 291 F IC	"	1
		(Pos. 10-13-14-15-17)	
C 18	1610.025 272 FV C	bronz.l.volano/flywh.side bear. std.	1 1 1
"	1610.057 272 FV CR10	" " -0,50	1 1 1
"	1610.026 272 F CR	" " -1,00	1 1 1
C 19	8430.055 9 S IC 10	spina/locking needle	1 1 1
C 20	4700.008 270 FV C 50	quarnizione/gasket 0,30	1 1 1
"	4700.074 279 N 50	" " 0,10	1 1 1
C 21	8675.067 270 F C	supporto/support	1 1 1
C 22	1210.078 9 FV C 10	anello tenuta/seal ring std.	1 1 1
"	1210.083 9 FV CR10	" " -1,00	1 1 1
C 23	9880.779 272 S IC	volano/flywheel std.	1 1 1
C 23	9880.726 272 S IC	VOLANO COMPLETO/FLYWHEEL ASS.Y (Pos. 6-23)	1
C 24	1860.011 270 S C	bullone/bolt	1 1 1
C 25	9718.216 272 S AC	ventola/fan	1 1 1
C 26	7625.008 9 D AC 10	rondella/washer	8 8 8
C 27	9730.016 9 FVAC 10	vite/screw M 6 X 35	8 8 8

Motore/Engine	4LD 640	Versione/Version	710170
"	4LD 705	"	710390
"	4LD 820	"	710320



DISTRIBUZIONE E REGOLATORE DI GIRI/TIMING AND SPEED GOVERNOR

Pos.	Matricola/Part No.	Note/Remarks	Q.ty/Eng.
D 1+	1165.001 9 S 10	anello/circlip	1 1 1
D 2+	7625.074 9 N 10	rondella/washer	1 1 1
D 3	=4882.001 270 S C	FORCELLA COMPLETA/YOKE ASS.Y (Pos. 1-2-3-4-5-9-10-14-15-16-17-19-20-21-23-24)	1 1 1
D 3+	5199.008 270 S C	leva/lever	1 1 1
D 4+	5800.015 270 D C 10	molla/spring	1 1 1
U 5+	8231.037 270 D C 10	perno/pin	1 1 1
D 6	9520.023 270 S C	tubo prot./guard tube	1 1 1
D 7	4740.017 292 FV C 10	guarnizione/gasket	1 1 1
D 8	1410.011 270 FV C	asta punteria/push rod	1 1 1
D 9+	8420.012 9 D C 10	spina/locating pin	2 2 2
D 10+	6140.013 270 D C 10	perno/pin	1 1 1
D 11	4840.008 270 FV C	guida/guide	1 1 1
D 12	9730.028 9 F 10	vite/screw M 8 X 1,25 X 30	2 2 2
D 13	4740.017 292 FV C 10	guarnizione/gasket	1 1 1
D 14+	1755.004 9 D C 10	bullone/bolt M 5 X 0,8 X 18	1 1 1
D 15+	6330.061 285 D 10	piastrina/safety plate	1 1 1
U 16+	1557.021 270 D C 10	blocchetto/spacer	1 1 1
D 17+	5655.005 270 FV C 10	molla/spring	1 1 1
D 18	1760.012 9 D C 10	bullone/bolt M 6 X 1 X 35	1 1 1
D 19+	8615.020 270 D C	supporto/support	1 1 1
D 20+	1755.002 9 D 10	bullone/bolt M 5 X 0,8 X 12	1 1 1
D 21+	5655.005 270 FV C 10	molla/spring	1 1 1
D 22	8245.011 9 F C 10	sfera/ball	6 6 6
D 23+	3945.027 270 S C	forcella/yoke	1 1 1
D 24+	1165.006 9 D C 10	anello/circlip	1 1 1
D 25	9800.082 9 N 10	vite/screw M 6 X 1 X 35	1 1 1
D 26	9732.092 9 F C 10	vite/screw M 8 X 1,25 X 18	1 1 1
U 27	4535.013 270 FV C 10	guarnizione/gasket	1 1 1
D 28	4535.013 270 FV C 10	guarnizione/gasket	1 1 1
D 29	5168.005 270 D C 10	lamierino/tabwasher	1 1 1
D 30	1750.035 9 S C 10	bullone/bolt M 4 X 0,7 X 12	2 2 2
D 31	6275.038 270 DV C 10	piastra/plate	1 1 1
D 32	6370.428 292 N I	piastrina/safety plate	1 1 1
D 33	1240.006 9 FV C 10	anello seeger/snap ring	1 1 1
D 34	7700.069 270 S C 10	rondella/washer	1 1 1
D 35	6130.016 271 S C	perno/governor shaft	1 1 1
D 36	7625.019 9 S 10	rondella/washer	1 1 1
D 37	3240.033 9 FV 10	dado/nut	1 1 1
U 38	4936.168 292 N I	ingranaggio/gearwheel	1 1 1
D 39	2085.029 270 F	campana regol./governor bell	1 1 1
D 40	1770.015 9 F 10	bullone/bolt M 8 X 1,25 X 55	1 1 1
D 41	7565.007 9 F C 10	rondella/washer	1 1 1
D 42	1240.013 9 D 10	anello seeger/snap ring	1 1 1
D 43	4330.028 270 F C	bilanc.pompa iniez./inj.pump rocker	1 1 1
D 44	6045.009 271 F C C	perno/pin	1 1 1
D 45	4887.002 270 FV C	punteria/tappet	1 1 1
D 46	1010.060 291 F C	albero a camme/camshaft	1 1 1
D 47	4887.001 270 FV C	punteria/tappet	1 1 1

Motore/Engine 4LD 640 Versione/Version 710170
 " " 4LD 705 " " 710390
 " " 4LD 820 " " 710320

LOMBARDINI MOTORI F.I.M. S.p.a.



BASAMENTO, PORTINA LATO DISTRIBUZIONE E PIEDI/CRANKCASE, COVER GEAR AND MOUNTS

Pos.	Matricola/Part No.	Note/Remarks	Q.ty/Eng.
E 1	=6646.091 272 D IC	PORTINA DISTR./GEAR SIDE CASE COVER (Pos. 1-9)	1 1 1
E 2	4431.004 270 SV C 50	guarnizione/gasket 0,40	1 1 1
E 3+	6850.024 270 SV C	prigioniero/stud	2 2 2
E 4+	6850.040 270 S C	prigioniero/stud	2 2 2
E 5	1610.009 270 FV C	bronz.l.distr./gear side bear. std.	1 1 1
"	1610.058 270 FV CR10	" " -0,50	1 1 1
"	1610.010 270 T CR	" " 1,00	1 1 1
E 6+	6800.059 9 D 10	prigioniero/stud M 10 X 30 (39)	1 1 1
E 7+	6800.018 9 D 10	prigioniero/stud M 10 X 32 (47)	1 1 1
E 8+	6800.010 9 S C 10	prigioniero/stud M 10 X 25 (40)	5 5 5
"	6800.010 9 S C 10	prigioniero/stud M 10 X 25 (40)	3 3 3
E 9+	8990.008 9 S 10	tappo/plug	1 1 1
E 10	3021.029 9 FVIC	cuscinetto/ball bearing	1 1 1
E 11+	8430.055 9 S IC 10	spina/locking needle	1 1 1
E 12+	4670.060 9 FV C 10	guarnizione/copper gasket	1 1 1
E 13+	4670.058 9 FV C 10	guarnizione/copper gasket	1 1 1
E 14+	4730.021 270 SV C 10	guarnizione/gasket	1 1 1
E 15+	1770.001 9 FV 10	Bullone/bolt M 9 X 1,25 X 12	1 1 1
E 16+	8965.003 9 FV C 10	tappo/plug	1 1 1
E 17	=3901.041 270 S C	FLANGIA OLIO/OIL FLANGE (Pos. 12-13-14-15-16-17-18)	1 1 -1
E 18+	9732.064 9 S 10	vite/screw M 8 X 1,25 X 30	2 2 2
E 19	7565.011 9 F C 10	rondella/washer	8 8 8
E 20	1210.031 9 FV C 10	anello tenuta/seal ring	1 1 1
E 21	3240.033 9 FV 10	dado/nut	6 6 6
E 22	7565.011 9 F C 10	rondella/washer	6 6 6
E 23+	6800.053 9 S C 10	prigioniero/stud M 10 X 10 (33)	5 5 5
E 24	=1511.069 272 D IC	BASAMENTO COMPLETO/CRANKCASE ASS.Y	1 1 1
"	=1511.081 279 S IC	" " " "	1 1 1
"	=1512.004 291 D IC	" " " "	1 1 1
		(Pos. 3-4-6-7-8-11-12-13-14-15-16-17-18-23-24-25-26-27-28-29)	
E 25+	4580.047 560 FVIC 10	guarnizione/gasket 1,00	1 1 1
"	4580.049 560 FV C 10	" " 0,50	1 1 1
"	4580.050 560 FV C 10	" " 0,80	1 1 1
E 26+	6780.012 255 S C	portina/pan	1 1 1
E 27+	6780.012 9 DV C 10	prigioniero/stud M 8 X 25 (37)	2 2 2
E 28+	7555.007 9 DV C 10	rondella/washer	2 2 2
E 29+	3240.018 9 FV 10	dado/nut	2 2 2
E 30	6426.010 270 D C	piede/engine mount	2 2 2
E 31	1780.005 9 FV 10	bullone/bolt M 10 X 1,5 X 28	8 8 7

Motore/Engine 4LD 640 Versione/Version 710170
 " " 4LD 705 " " 710390
 " " 4LD 820 " " 710320



CIRCUITO COMBUSTIBILE/FUEL SYSTEM

Pos.	Matricola/Part No.	Note/Remarks	Q.ty/Eng.
F 1	=9043.037 285 FV C	TAPPO SERBATOIO/TANK CAP (Pos.1-2)	1 1 1
F 2+	1200.015 9 FV C 10	anello tenuta/seal ring	1 1 1
F 3	=8101.018 270 F C	SERBATOIO COMPLETO/FUEL TANK (Pos. 1-2-3)	1 1 1
F 4	7565.007 9 F C 10	rondella/washer	2 2 2
F 5	1770.007 9 F C 10	bullone/bolt	2 2 2
F 6	5390.006 260 S C 10	manicotto/rubber sheating	1 1 1
F 7	7565.007 9 F C 10	rondella/washer	1 1 1
F 8	1770.042 9 D C 10	bullone/bolt	1 1 1
F 9+	1570.016 260 DV C	bocchettone/filler cap	1 1 1
F 10+	4130.053 260 SV C	ghiera/ring nut	1 1 1
F 11	4670.058 9 FV C 10	guarnizione/copper gasket	2 2 2
F 12+	1901.029 9 FVIC 10	bullone raccordo/connection bolt	1 1 1
F 13+	7265.008 271 FV C 10	raccordo/connection	1 1 1
F 14	3617.016 2830 S C 10	fascetta/strip fixing	1 1 1
F 15	9370.002 270 FV C	tubo comb./fuel pipe	1 1 1
F 16+	4370.007 260 DV C 10	guarnizione/gasket	1 1 1
F 17+	5800.038 260 SV C	molla/spring	1 1 1
F 18+	6578.013 283 FV C	pompante/injection plunger	1 1 1
F 20+	9672.013 273 F C	valvolina mandata/delivery valve	1 1 1
F 21+	1200.031 9 FV C 10	anello OR/rubber oil seal	1 1 1
F 22+	8335.029 271 SV C 10	spessore/shim	1 1 1
F 23+	7470.003 271 FV C 10	riempitore/filler	1 1 1
F 24+	5755.034 271 SV C 10	molla/spring	1 1 1
F 25	9570.067 270 FV C 10	tubo spurgo in./bleeding pipe	1 1 1
F 26+	7301.006 500 D I	raccordo/connection	1 1 1
F 27+	4650.037 260 DV C 10	guarnizione/gasket	1 1 1
F 28+	1420.012 260 DV C	asta comando/control rod	1 1 1
F 29	3240.095 9 FV C 10	dado/nut	2 2 2
F 30+	5575.006 273 FV C 10	molla/spring	1 1 1
F 31+	3930.019 273 F C 10	fondello/cup	1 1 1
F 32+	1200.032 9 FV C 10	anello OR/rubber oil seal	1 1 1
F 33	4670.060 9 FV C 10	guarnizione/copper gasket	1 1 1
F 34+	4760.015 271 FV C 10	guarnizione/gasket	1 1 1
F 35	4670.060 9 FV C 10	guarnizione/copper gasket	1 1 1
F 36	1901.031 9 FVIC 10	bullone raccordo/connection bolt	1 1 1
F 37	4775.196 9 SV C 10	guarnizione/gasket	1 1 1
F 38	9080.037 9 FV C 10	tappo/deaeration cap	1 1 1
F 39	=6615.015 291 F C	PORTAPOLVERIZZATORE/NOZZLE-HOLDER (Pos. 9-10-12-16-17-18-26-27-28-39-40-41)	1 1 1
F 40+	6531.265 710 FVIC	polverizzatore/nozzle	1 1 1
F 41+	4130.052 260 SV C	ghiera/ring nut	1 1 1
F 42+	6780.018 9 FV C 10	prigioniero/stud M 8 X 28 (43)	2 2 2
F 43	=2730.015 273 FV C	FILTRO COMBUSTIBILE/FUEL FILTER (Pos. 30-31-32-43-44-45-61-62-63)	1 1 1
F 43+	2175.009 273 FV C	cartuccia comb./f.filter element	1 1 1
F 44+	4490.017 273 FV C 10	guarnizione/gasket	1 1 1
F 45+	4430.071 260 FV C 10	guarnizione/gasket	1 1 1
F 46	3240.018 9 FV 10	dado/nut	2 2 2
F 47	7565.007 9 F C 10	rondella/washer	2 2 2
F 48	7625.012 9 FV C 10	rondella/washer	2 2 2
F 49	3525.093 270 S C 10	distanziale/spacer	2 2 2
F 50	1770.011 9 S C 10	bullone/bolt M 8 X 1,25 X 40	2 2 2
F 51	9732.074 8 S C 10	vite/screw M 8 X 1,25 X 20	3 3 3
F 52+	1415.007 270 DV C	asta comando/control rod	1 1 1
F 53+	6230.075 277 S 10	perno/pin	1 1 1
F 54	1580.016 270 F C 10	boccola/bushing	1 1 1
F 55	7626.017 9 N 10	rondella/washer	1 1 1
F 56	4670.009 9 FV C 10	guarnizione/copper gasket 0,50	1 1 1
"	4670.010 9 FV C 10	" " 1,00	1 1 1
"	4670.011 9 FV C 10	" " 1,50	1 1 1
F 57+	7980.020 260 SV C	scodellino/cup	1 1 1
F 58+	4850.009 260 FV C	guida/guide	1 1 1

Motore/Engine	4LD 640	Versione/Version	710170
"	4LD 705	"	710390
"	4LD 820	"	710320

LOMBARDINI MOTORI F.I.M. S.p.a.



Segue riquadro/Continues F

Pos.	Matricola/Part No.	Note/Remarks	Q.ty/Eng.
F 59	=6590.033 283 F C	POMPA INIEZIONE/INJECTION PUMP (Pos. 13-19-20-21-22-23-24-34-52-53-57-58-59-50-66-67-68-69-70-71-73)	1 1 1
F 60+	1260.084 9 DV C 10	anello/ring	1 1 1
F 61+	2605.033 273 F AC	coperchio/filter cover	1 1 1
F 62+	1760.076 9 D A	bullone/bolt	1 1 1
F 63+	1202.052 9 FVAC 10	anello OR/rubber oil seal	1 1 1
F 64	3630.008 9 F C 10	fascetta/clamp	1 1 1
F 65	9375.274 273 FVAC	tubo da serb.lato dist.a pompa in.	1 1 1
F 66+	5625.002 260 SV C	molla/spring	1 1 1
F 67+	6400.024 260 D	piattello/retainer	1 1 1
F 68+	7770.020 260 SV C	rullo/roller	1 1 1
F 69+	1970.054 260 DV C	bussola/sleeve	1 1 1
F 70+	6230.068 260 SV C	perno/pin	1 1 1
F 71+	7215.017 260 FV C	punteria/tappet	1 1 1
F 72	4580.001 283 D 50	guarnizione/gasket 0,10	1 1 1
"	4580.008 283 N 50	" " 0,50	1 1 1
"	4580.012 283 N 50	" " 0,30	1 1 1
"	4580.039 283 N 10	" " 0,05	1 1 1
F 73+	6230.069 260 DV C	perno/pin	1 1 1
F 74	2800.003 9 F C 10	copiglia/cotter pin	1 1 1

Motore/Engine	4LD 640	Versione/Version	710170
"	4LD 705	"	710390
"	4LD 820	"	710320



RAFFREDDAMENTO/COOLING SYSTEM

Pos.	Matricola/Part No.	Note/Remarks	Q.ty/Eng.
G 1	5065.009 270 F C	lamiera/airtight plate	1 1 1
G 2	1760.003 9 F 10	bullone/bolt M 6 X 1 X 12	4 4 4
G 3	7565.004 9 F C 10	rondella/washer	4 4 4
G 4	7625.007 9 S C 10	rondella/washer	4 4 4
G 5	3240.008 9 FV 10	dado/nut	3 3 3
G 6	2565.076 270 F IC	convogliatore/shroud	1 1
G 7	3203.059 9 N 10	dado/nut	2
G 8	6820.014 9 D 10	prigioniero/stud M 12 X 30 (48)	2
G 9	7625.026 9 S 10	rondella/washer	2
G 10	6371.039 291 F C	piastra/shroud plate	1
G 11	2565.070 270 F C C	convogliatore/shroud	1
G 12	9245.025 270 S C 10	tirante/tie rod	1 1 1
G 13	7625.005 9 FV C 10	rondella/washer	1 1 1
G 14	3240.003 9 FV C 10	dado/nut	1 1 1
G 15	3240.003 9 FV C 10	dado/nut	1 1 1
G 16	5065.012 270 F C	lamiera/airtight plate	1 1 1
G 17			
G 18	5065.057		
G 19	6685.045 270 S	portina/cover	1
G 21	4775.042 422 N 50	guarnizione/gasket	1
G 22	7500.018 271 SV C 10	rondella/washer	7
G 23	1755.001 9 FV 10	bullone/bolt M 5 X 0,8 X 8	7

Motore/Engine	4LD 640	Versione/Version	710170
"	4LD 705	"	710390
"	4LD 820	"	710320
"	"	"	"

LOMBARDINI MOTORI F.I.M. S.p.a.



CIRCUITO DI LUBRIFICAZIONE/LUBRICATING SYSTEM

Pos.	Matricola/Part No.	Note/Remarks	Q.ty/Eng.
H 1+	9765.001 9 S C 10	vite/screw M 6 X 1 X 8	1 1 1
H 2	9730.030 9 S C 10	vite/screw M 8 X 1,25 X 35	2 2 2
H 3	7625.010 9 FV C 10	rondella/washer	2 2 2
H 4	=4336.023 272 F IC	POMPA OLIO/LUBR.OIL PUMP ASS.Y (Pos. 1-4-5-6)	1 1 1
H 5+	vedi/see Pos. 4 ...	
H 6+	vedi/see Pos. 4 ...	
H 7	1400.005 270 F C 10	asta liv./dipstick	1 1 1
H 8	7700.014 270 N 10	rondella/washer	1 1 1
H 9	9320.046 270 S C	tubo/pipe	1 1 1
H 10	9730.010 9 S 10	vite/screw M 6 X 1 X 16	2 2 2
H 11	3203.014 9 FV C 10	dado/nut	1 1 1
H 12	7625.010 9 FV C 10	rondella/washer	1 1 1
H 13	4975.018 272 F IC	ingranaggio/gearwheel	1 1 1
H 14	9730.015 9 F C 10	vite/screw M 6 X 1 X 30	1 1 1
H 15	7565.004 9 F C 10	rondella/washe	1 1 1
H 16	7625.007 9 S C 10	rondella/washe	1 1 1
H 17	7625.010 9 FV C 10	rondella/washer	10 10 10
H 18	1770.002 9 FV 10	bullone/bolt M 8 X 1,25 X 16	10 10 10
H 19	6645.040 270 S C	portina/oil pan	1 1 1
H 20	4600.091 270 FV C 10	guarnizione/gasket	1 1 1
H 21	4670.016 9 FV C 10	guarnizione/copper gasket	1 1 1
H 22	8965.005 9 FV C 10	tappo/oil drain plug	1 1 1

Motore/Engine	4LD 640	Versione/Version	710170
"	4LD 705	"	710390
"	4LD 820	"	710320



COMANDI/CONTROLS

Pos.	Matricola/Part No.	Note/Remarks	Q.ty/Eng.	
I 1+	5200.159	283 F AC 10	leva/lever	1 1 1
I 2+	8420.001	9 D C 10	spina/locating pin	1 1 1
I 3+			vedi/see Pos. 5 ...	
I 4+	1200.041	9 FV 10	anello OR/rubber oil seal	1 1 1
I 5	=2516.045	272 F IC	COMANDO SUPPLEMENTO/DEVICE CONTROL (Pos. 2-3-4-5-7-8)	1 1 1
I 6+	4700.070	270 N 50	guarnizione/gasket 0,25	1 1 1
I 7+	5550.007	270 SV C 10	molla/spring	1 1 1
I 8+			vedi/see Pos. 5 ...	
I 9+	1165.001	9 S 10	anello/circlip	1 1 1
I 10+	3240.004	9 FV C 10	dado/nut	1 1 1
I 11+	6330.057	90 F C 10	piastrina/safety plate	1 1 1
I 12+	7625.019	9 S 10	rondella/washer	1 1 1
I 13+	9820.109	272 D AC 10	vite/fixing screw	1 1 1
I 14+	7625.007	9 S C 10	rondella/washer	1 1 1
I 15	1760.005	9 FV 10	bullone/bolt M 6 X 1 X 16	2 2 2
I 16+	9245.031	270 S C 10	tirante/tie rod	1 1 1
I 17	7625.059	9 D C 10	rondella/washer	2 2 2
I 18+			vedi/see Pos. 37 ...	
I 19+	5200.254	272 D AC	leva/lever	1 1 1
I 20+	7865.088	272 D AC	scatola comando/control housing	1 1 1
I 21+	3240.008	9 FV 10	dado/nut	1 1 1
I 22+	1760.029	9 D A 10	bullone/bolt M 6 X 1 X 30	1 1 1
I 23+	3240.008	9 FV 10	dado/nut	1 1 1
I 24+	1760.029	9 D C 10	bullone/bolt M 6 X 1 X 30	1 1 1
I 25+	3200.015	9 FVIC 10	dado/nut	1 1 1
I 26+	7626.054	9 S AC 10	rondella/washer	2 2 2
I 27+	9790.037	9 FV C 10	vite/screw M 6 X 1 X 8	2 2 2
I 28	=2515.029	273 F C	COMANDO ACCELERATORE/ACCELER. CONTROL (Pos. 1-9-10-11-12-13-14-16-18-19-20- 21-22-23-24-25-26-27-28-29-30-31-32- 33-35-37)	1 1 1
I 28+	2690.122	283 F AC 10	coperchio/cover	1 1 1
I 29+	6370.114	283 S AC 10	piastra/plate	1 1 1
I 30+	5680.025	270 SV C 10	molla/spring	1 1 1
I 31+	1200.041	9 FV 10	anello OR/rubber oil seal	1 1 1
I 32+	1770.042	9 D C 10	bullone/bolt M 8 X 1,25 X 10	1 1 1
I 33+	7555.007	9 FV C 10	rondella/washer	1 1 1
I 34	9800.061	9 F C 10	vite/screw M 6 X 1 X 16	3 3 3
I 35+	8420.012	9 D C 10	spina/locating pin	1 1 1
I 36	4700.069	270 N 50	guarnizione/gasket	1 1 1
I 37	=5200.292	283 S C	LEVA COMPLETA/LEVER ASS.Y (Pos. 18-35-37)	1 1 1

Motore/Engine 4LD 640 Versione/Version 710170
 " " 4LD 705 " " 710390
 " " 4LD 820 " " 710320



TESTA, CAPPELLO BILANCIERI E VALVOLE/CYLINDER HEAD, ROCKER ARM BOX AND VALVES

Pos.	Matricola/Part No.	Note/Remarks	Q.ty/Eng.
L 1	=2125.083 272 S IC	COPERCHIO BILANC./ROCKER BOX CAP (Pos. 1-6-7)	1 1 1
L 2+	1200.014 9 FVIC 10	anello OR/rubber oil seal	1 1 1
L 3	=9050.050 530 FVIC	TAPPO SFIATO/BREATHER CAP (Pos. 2-3)	1 1 1
L 4	9055.003 270 FV C 10	tappo/starter cap	1 1 1
L 5	3695.038 500 F C 10	filo/wire	1 1 1
L 6+	8506.003 904 S AC 10	squadretta/angle bracket	1 1 1
L 7+	9732.063 9 S AC 10	vite/screw M 8 X 1,25 X 35	2 2 2
L 8+	9850.002 270 F C 10	vite/screw	1 1 1
L 9+	3240.010 9 FV C 10	dado/nut	1 1 1
L 10	=4330.023 291 F C	GRUPPO BILANC./ROCKER ARM ASS.Y (Pos. 8-9-10-11-12-13-14-15-23)	1 1 1
L 11+	6045.029 291 FV C 10	perno bil./rocker shaft	1 1 1
L 12+	9765.051 9 F C 10	vite/screw M 6 X 1 X 8	1 1 1
L 13+	9850.002 270 F C 10	vite/screw	1 1 1
L 14+	3240.010 9 FV C 10	dado/nut	1 1 1
L 15+	6800.050 9 S I 10	vedi/see Pos. 10	1 1 1
L 16+	4400.007 270 FV C 50	prigioniero/stud M 10 X 23 (38)	2 2 2
L 17	1160.013 291 FV C 10	guarnizione/gasket 0,50	1 1 1
L 18+	4845.158 291 FVICR10	anello/circlip	1 1 1
L 19+	4845.159 291 FVICR10	guida v., aspir./inlet v., guide std.	1 1 1
L 20+	4845.160 291 FVACR10	guida v., scar./exhaust v., guide +0,50 std.	1 1 1
L 21+	4845.161 291 FVACR10	guida v., scar./exhaust v., guide :0,50 std.	1 1 1
L 22	1160.013 291 FV C 10	anello/circlip	1 1 1
L 23+	3206.015 270 FV C 10	dado/nut	4 4 4
L 24	1200.027 9 FV C 10	anello OR/rubber oil seal	1 1 1
L 25+	7625.227 9 N 10	rondella/washer	4 4 4
L 26+	2135.067 270 FV C 10	cappellotto/cap	1 1 1
L 26+	6410.018 260 F C 10	piattello/retainer with half-colletts	2 2 2
L 27	=9201.003 291 F C	TESTA COMPLETA/CYLINDER HEAD ASS.Y (Pos. 8-9-10-11-12-13-14-15-16-18-19-20-21-23-25-26-27-29-30-31-32-33-34-35-36-F 42)	1 1 1
L 27	=9201.004 291 F C	TESTA SEMICOMPLETA/CYLINDER HAED (Pos. 16-18-19-20-21-27-29-30-31-F 42)	1 1 1
L 28+	4730.107 272 SVAC 10	guarnizione/head gasket 0,70	1 1 1
"	4730.108 272 SVAC 10	" " 0,80	1 1 1
"	4730.109 272 DVAC 10	" " 0,90	1 1 1
"	4730.110 272 DVAC 10	" " 1,00	1 1 1
"	4730.111 272 DVAC 10	" " 1,10	1 1 1
"	4730.112 279 S A 50	" " 0,70	1 1 1
"	4730.113 279 S A 50	" " 0,80	1 1 1
"	4730.114 279 S A 50	" " 0,90	1 1 1
"	4730.115 279 S A 50	" " 1,00	1 1 1
"	4730.116 279 S A 50	" " 1,10	1 1 1
L 29+	8000.046 291 FV CR10	sede v. aspirazione/inlet v. seat	1 1 1
L 30+	8000.047 291 FV CR10	sede v. scarico/exhaust v. seat	1 1 1
L 31+	6800.050 9 S I 10	prigioniero/stud M 10 X 23 (38)	2 2 2
L 32+	8990.017 9 F C 10	tappo/plug	1 1 1
L 33+	6410.037 291 F IC 10	piattello/retainer	2 2 2
L 34+	9652.019 291 FV CR	valvola aspirazione/inlet valve	1 1 1
L 35+	9685.031 291 FV CR	valvola scarico/exhaust valve	1 1 1
L 36+	5755.004 260 FV C	molla/spring	2 2 2

" " 4LD 705 " " 710390
 " " 4LD 820 " " 710320



AVVIAMENTO/STARTING

Pos.	Matricola/Part No.	Note/Remarks	Q.ty/Eng.
M 1	6960.061 270 FV C	puleggia avv./st.pulley	1 1 1
M 2	7555.007 9 DV C 10	rondella/washer	6 6 6
M 3	1770.006 9 S 10	bullone/bolt M 8 X 1,25 X 25	6 6 6
M 4	4055.003 283 F C	fune avviamento/rope starting	1 1 1

Motore/Engine	4LD 640	Versione/Version	710170
"	4LD 705	"	710390
"	4LD 820	"	710320

LOMBARDINI MOTORI F.I.M. S.p.a.



COMPOSIZIONE SERIE GUARNIZIONI/GASKET SET COMPOSITION

Pos.	Matricola/Part No.	Note/Remarks	Q.ty/Eng.
xxx	=8180.024 272 FV CR	SERIE GUARNIZIONI/GASKET SET	1
"	=8180.027 279 FV CR	" "	1
"	=8180.038 291 FV CR	" "	1
A 4	4501.003 710 FV C 50	guarnizione/gasket	2 2 2
A 5	4500.097 710 FV C 10	guarnizione/gasket	2 2 2
A 10	4500.079 276 FV C 10	guarnizione/gasket	1
B 11	4410.361 272 D A 50	guarnizione/gasket	1
"	4410.062 279 D A 50	" "	1
"	4410.063 291 D A 50	" "	1
C 5	4760.007 271 DV C 10	guarnizione/gasket	1 1 1
C 20	4700.008 270 FV C 50	guarnizione/gasket	1 1 1
"	4700.074 279 N 50	" " 0,30	1 1 1
D 27	4535.013 270 FV C 10	guarnizione/gasket	1 1 1
D 28	4535.013 270 FV C 10	guarnizione/gasket	1 1 1
E 2	4431.004 270 SV C 50	guarnizione/gasket	2 2 2
E 14	4730.021 270 SV C 10	guarnizione/gasket	1 1 1
E 25	4580.047 560 FVIC 10	guarnizione/gasket	1 1 1
F 72	4580.001 283 D 50	guarnizione/gasket	1 1 1
"	4580.008 283 N 50	" " 0,50	1 1 1
"	4580.012 283 N 50	" " 0,30	1 1 1
H 20	4600.091 270 FV C 10	guarnizione/gasket	1 1 1
I 6	4700.070 270 N 50	guarnizione/gasket	1 1 1
I 36	4700.069 270 N 50	guarnizione/gasket	1 1 1
L 17	4400.007 270 FV C 50	guarnizione/gasket	1 1 1
L 28	4730.108 272 SVAC 10	" " 0,80	1
"	4730.109 272 DVAC 10	" " 0,90	1
"	4730.113 279 S A 50	" " 0,80	1 1
"	4730.114 279 S A 50	" " 0,90	1 1

Motore/Engine	4LD 640	Versione/Version	710170
"	4LD 705	"	710390
"	4LD 820	"	710320

INDICE DELLE MODIFICHE/IMPROVEMENTS INDEX

Motori/Engines Gr. 4



Pos.	Nuova matricola New Part No.	vecchia matricola Old Part.No.	Vedi Circ.Tec. See Serv.Lett.	Q.ty/Eng.
A 1	=3700.139 272 FVIC	3702.026 272	1250	1 1
A 13	=3700.141 291 FVIC	3702.016 291	1251	1 1 1
A 14	5496.110 292 SVAC	1250/1251	1 1 1
A 18	1261.073 292 DVAC 10	3525.080 270	1250/1251	1 1 1
"	5496.111 292 FVIC	5496.052 272	1250	1 1
"	5496.118 291 FVIC	5496.018 291	1251	1
B 1	=6500.919 272 FVAC	6500.070 272	40002	1
"	=6500.920 272 F ACR	6500.071 272	40002	1
"	=6500.921 272 F ACR	6500.072 272	40002	1
"	=6500.922 279 FVAC	6501.021 279	40002	1
"	=6500.923 279 F ACR	6501.022 279	40002	1
"	=6500.924 279 F ACR	6501.023 279	40002	1
"	=6500.925 291 FVAC	6501.070 291	40002	1
"	=6500.926 291 F ACR	6501.071 291	40002	1
"	=6500.927 291 F ACR	6501.072 291	40002	1
B 2	8211.176 272 FVAC	8210.052 276	40002	1
"	8211.177 272 F ACR	8210.053 276	40002	1
"	8211.178 272 F ACR	8210.054 276	40002	1
"	8211.179 279 FVAC	8210.049 279	40002	1
"	8211.180 279 F ACR	8210.050 279	40002	1
"	8211.181 279 F ACR	8210.051 279	40002	1
"	8211.182 291 FVAC	8210.058 291	40002	1
"	8211.183 291 F ACR	8210.059 291	40002	1
"	8211.184 291 F ACR	8210.060 291	40002	1
B 3	8480.082 291 D AC	8480.025 291	40002	1
BB 9	3203.134 9 FVIC 10	3240.032 9	1245	2 2 2
BB 11	4410.061 272 D A 50	4410.008 272	1243	1
"	4410.062 279 D A 50	4410.023 279	1240	1
"	4410.063 291 D A 50	4410.037 291	1242	1
C 14	8990.002 9 F AC 10	8990.019 9	1241	1 1 1
C 17	=1051.091 272 F IC	1050.007 270	1232	1 1 1
C 19	=1051.092 291 F IC	1051.011 291	1232	1
C 23	8430.055 9 S IC 10	8460.054 270	5153	1 1 1
"	9880.779 272 S IC	9881.006 270	40002	1 1 1
"	=9880.726 272 S IC	"	40002	1
C 25	9718.216 272 S AC	40002	1 1 1
C 26	7625.008 9 D AC 10	40002	1 1 1
C 27	9730.016 9 FVAC 10	40002	1 1 1
DD 32	6370.428 292 N I	6370.038 270	40001	1 1 1
DD 38	4936.168 292 N I	4935.068 270	40001	1 1 1
E 1	=6646.091 272 D IC	6645.068 270	1232	1 1 1
E 10	3021.029 9 FVIC	1710.032 271	1232	1 1 1
E 11	8430.055 9 S IC 10	8460.054 270	5153	1 1 1
E 24	=1511.069 272 D IC	1511.063 272	5153	1
"	=1511.081 279 S IC	1511.075 279	5153	1
"	=1512.004 291 D IC	1511.096 291	5153	1
E 25	4580.047 560 FVIC 10	4580.006 272	5153	1 1 1
F 17	8010.002 260	D. . .	1 1 1
F 12	1901.029 9 FVIC 10	1900.002 9	5153	1 1 1
F 26	7301.006 500 D I	7300.035 260	5153	1 1 1
F 36	1901.031 9 FVIC 10	1900.067 9	5153	1 1 1
F 40	6531.265 710 FVIC	6531.033 710	5153	1 1 1
F 61	2695.033 273 F AC	2695.023 273	1248	1 1 1
F 62	1760.076 9 D A	1760.006 9	5007	1 1 1
F 63	1202.052 9 FVAC 10	4670.001 9	5007	1 1 1
F 65	9375.274 273 FVAC	9371.071 2830	1248	1 1 1
G 6	2565.076 270 F IC	2566.071 6035	5153	1 1 1
G 17	5095.057 270	40002	1 1 1
"	5095.081 291	40002	1
G 18	7540.006 9	40002	4 4 4
G 19	9810.012 9	40002	4 4 4
H 4	=4336.023 272 F IC	6605.003 270	5153	1 1 1
H 13	4975.018 272 F IC	4975.003 272	5153	1 1 1
I 1	5200.159 293 F AC 10	5200.099 270	1236	1 1 1
I 5	=2516.045 272 F IC	4875.002 271	5153	1 1 1
I 13	9820.109 272 D AC 10	9820.073 270	1244	1 1 1
I 19	5200.254 272 D AC	5200.086 270	1244	1 1 1
I 20	7865.088 272 D AC	7865.018 270	1244	1 1 1
I 22	1760.029 9 D A	1760.082 9	1244	1 1 1
I 25	3200.015 9 FVIC 10	3200.001 9	1236	1 1 1
I 26	7626.054 9 S AC 10	7625.005 9	1236	2 2 2
I 28	2690.122 283 F AC 10	2690.043 270	1236	1 1 1
I 29	6370.114 283 S AC 10	6140.071 270	1236	1 1 1
L 1	=2125.083 272 S IC	2125.024 270	596	1 1 1

Motore/Engine	4LD 640	Versione/Version	710170
"	4LD 705	"	710390
"	4LD 820	"	710320

LOMBARDINI MOTORI F.I.M. S.p.a.

INDICE DELLE MODIFICHE/IMPROVEMENTS INDEX
(segue/continues)

Motori/Engines Gr. 4



Pos.	Nuova matricola New Part No.	Vecchia matricola Old Part.No.	Vedi Circ.Tec. See Serv.Lett.	Q.ty/Eng.
L 2	1200.014 9 FVIC 10	1202.043 9	5153	1 1 1
L 3	=9050.050 530 FVIC	9050.021 270	5153	1 1 1
L 6	8506.003 904 S AC 10	4260.003 270	596	1 1 1
L 7	9732.063 9 S AC 10	1770.007 9	596	2 2 2
L 16	6800.050 9 S I 10	6800.051 9	5153	2 2 2
L 19	4845.158 291 FVICR10	4845.054 291	1254	1 1 1
	4845.159 291 FVICR10	4845.060 291	1254	1 1 1
L 20	4845.160 291 FVACR10	4845.055 291	1255	1 1 1
	4845.161 291 FVACR10	4845.061 291	1255	1 1 1
L 28	4730.107 272 SVAC 10	1243	1
"	4730.108 272 SVAC 10	1243	1
"	4730.109 272 DVAC 10	1243	1
"	4730.110 272 DVAC 10	1243	1
"	4730.111 272 DVAC 10	1243	1
"	4730.112 279 S A 50	1240, 1242	1 1
"	4730.113 279 S A 50	1240, 1242	1 1
"	4730.114 279 S A 50	1240, 1242	1 1
"	4730.115 279 S A 50	1240, 1242	1 1
"	4730.116 279 S A 50	1240, 1242	1 1
L 31	6800.050 9 S I 10	6800.051 9	5153	2 2 2
L 33	6410.037 291 F IC 10	1220	2 2 2

Motore/Engine 4LD 640 Versione/Version 710170
 " " 4LD 705 " " 710390
 " " 4LD 820 " " 710320

LOMBARDINI MOTORI F.I.M. S.p.a.