

TAVOLA RICAMBI
TABLEAU PIECES DETACHEES
SPARE PARTS TABLE
ERSATZTEILTAFEL
TABLA DE REPUESTOS
TÁBUA PEÇAS DE TROCA

4LD640
4LD705
4LD820

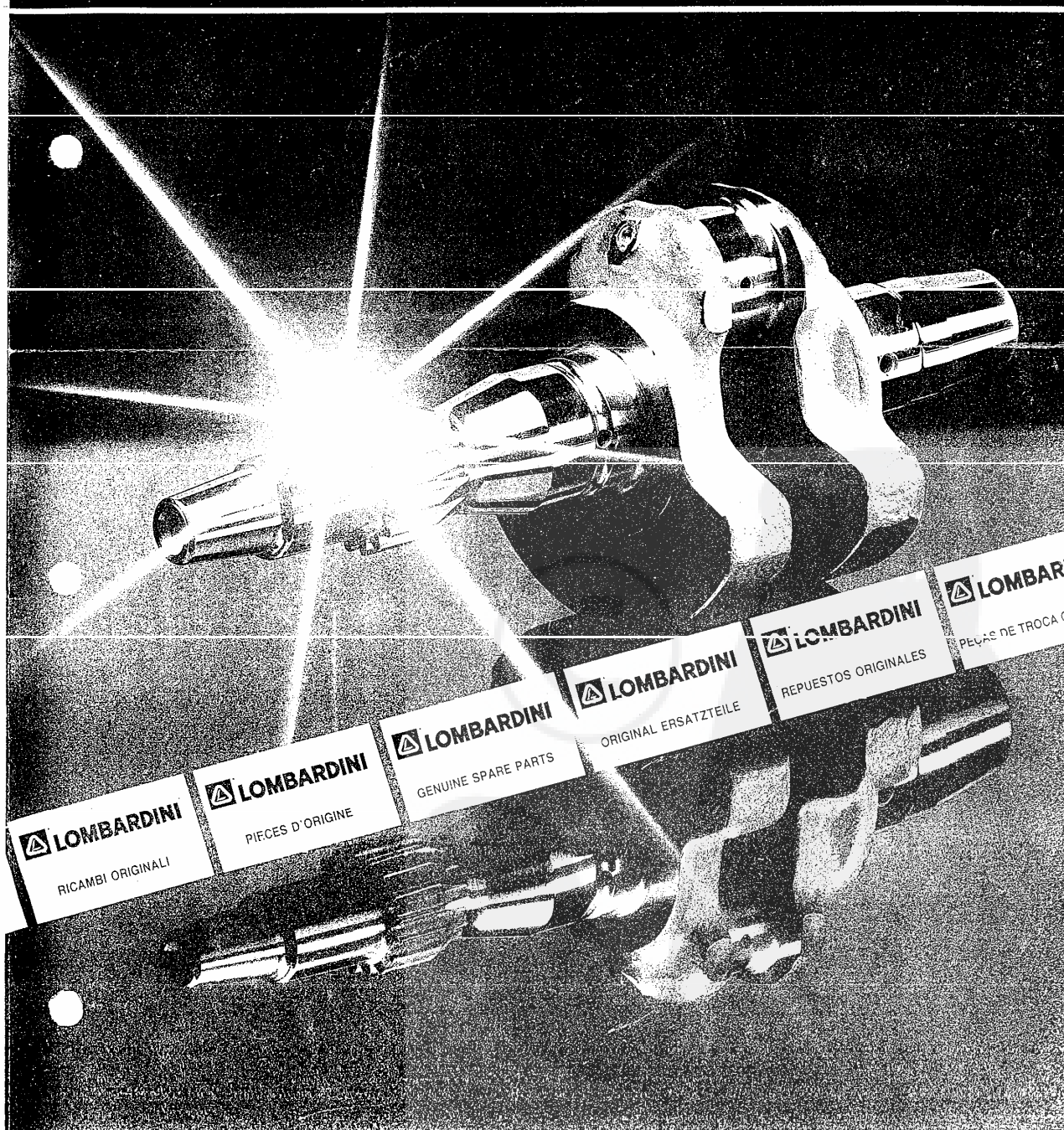

RICAMBI
PIECES
SPARE PARTS
ERSATZTEILE
REPUESTOS
RECÁMBIOS

RICAMBI PER MOTORE STANDARD.
PER APPLICAZIONI SPECIALI
CONSULTARE IL CATALOGO PRESSO I
CENTRI ASSISTENZA E RICAMBI.

PIECES POUR DES MOTEURS
STANDARD.
POUR LES ADAPTATIONS CONSULTER
LE CATALOGUE AUPRES DES AGENTS
SERVICE.

SPARE PARTS FOR STANDARD
ENGINE.
FOR SPECIAL APPLICATIONS SEE
MASTER CATALOG AT SERVICE
CENTERS.

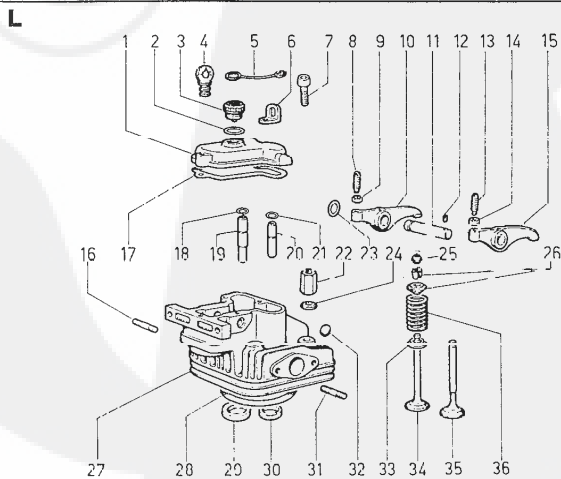
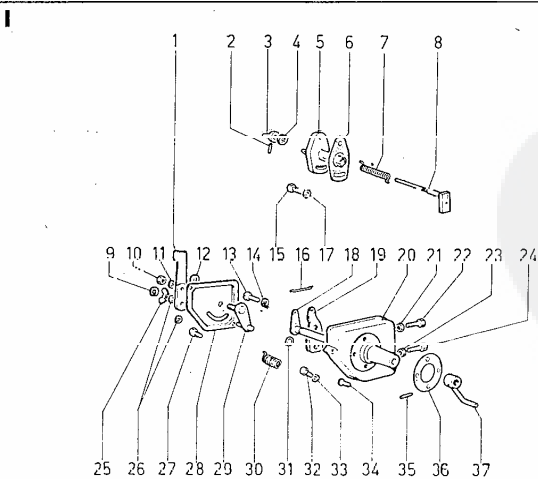
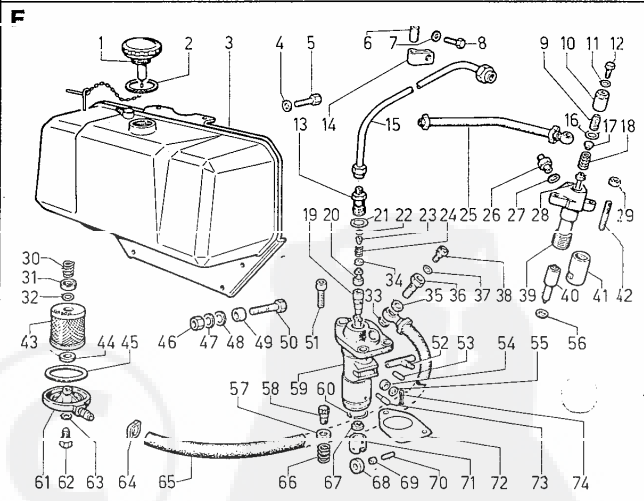
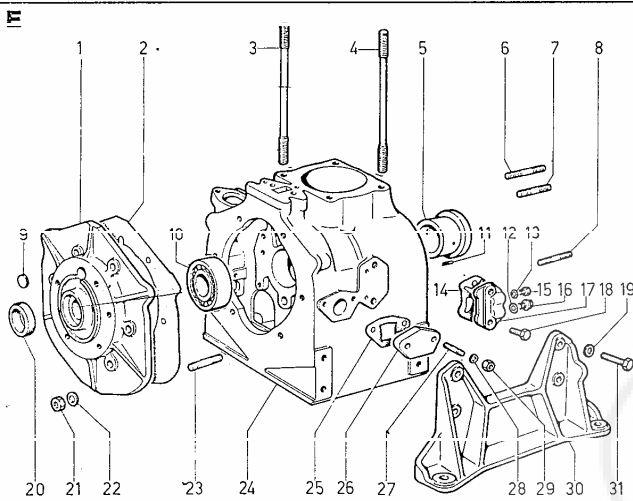
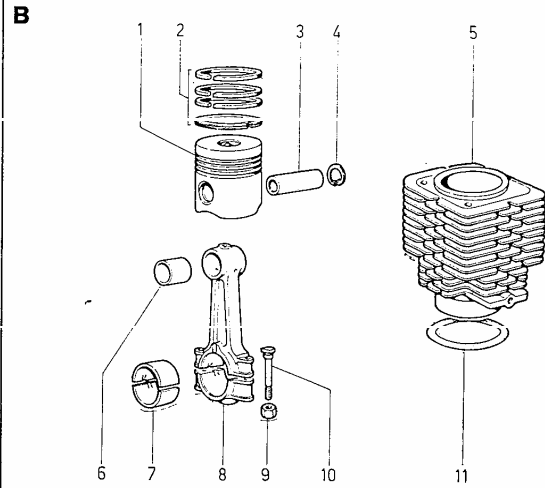
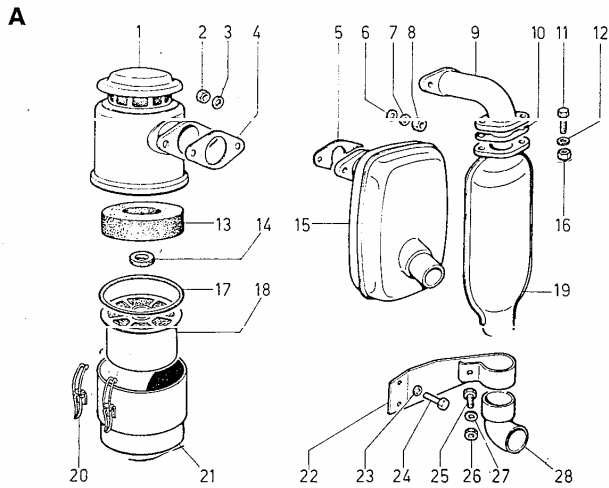

ERSATZTEILE FÜR STANDARD-
MOTOREN.
FÜR SONDERANFERTIGUNGEN SIEHE
ERSATZTEILKATALOG BEI SERVICE
WEF. ÄTTEN.

REPUESTOS PARA MOTORES
STANDARD.
PARA APLICACIONES VEASE
CATALOGO EN LAS ESTACIONES
SERVICE.

PEÇAS DE TROCA PARA MOTOR
STANDARD.
PARA APLICAÇÕES ESPECIAIS
CONSULTAR O CATÁLOGO NOS
CENTROS DE ASSISTÊNCIA E PEÇAS
DE TROCA.

GRUPPO

4

Matricola 1.5302.316

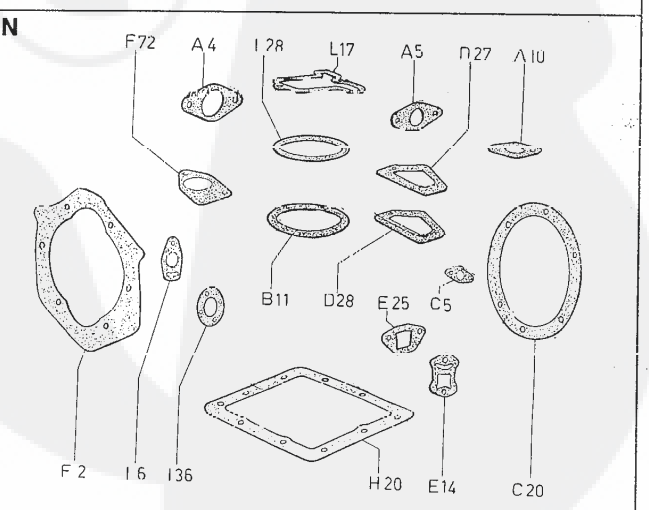
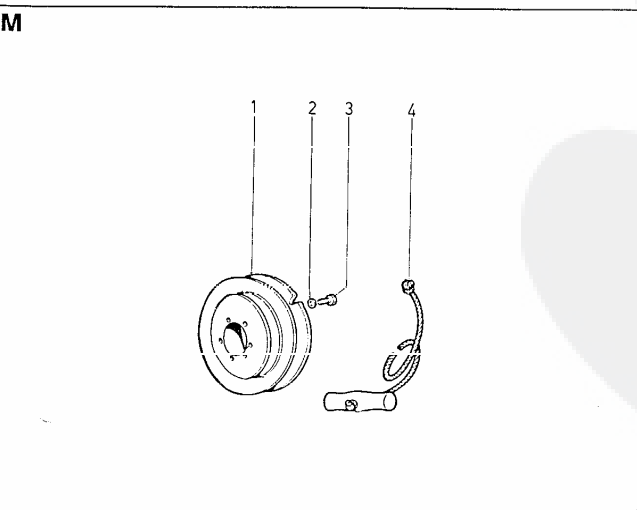
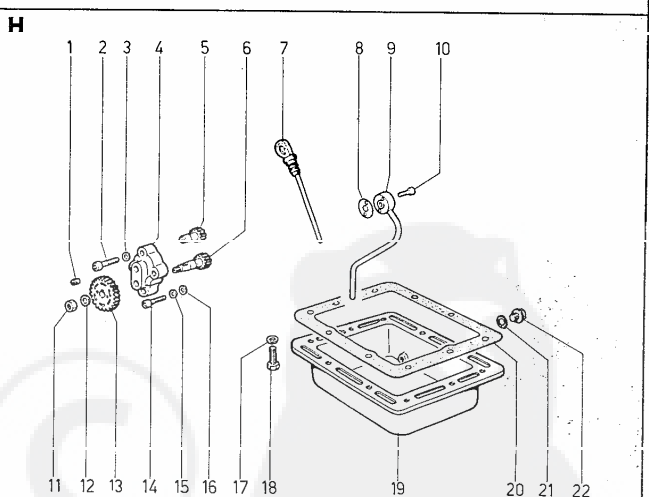
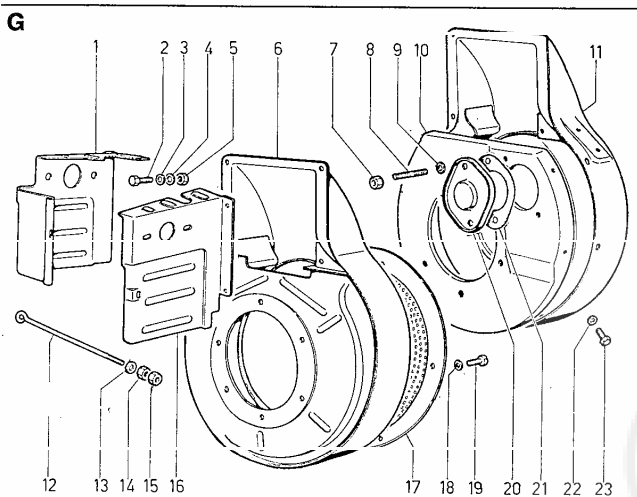
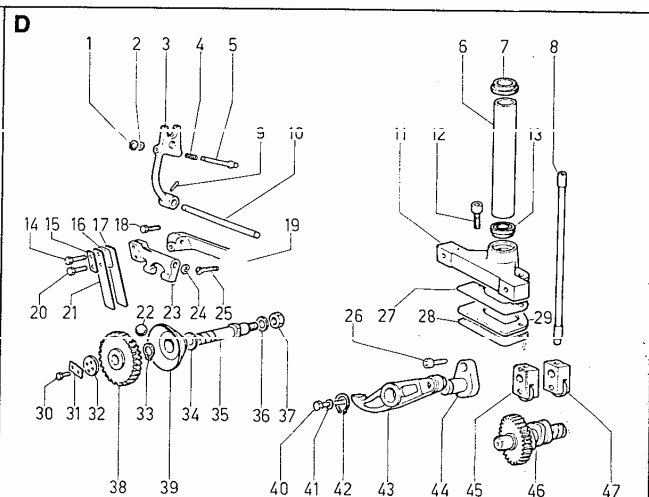
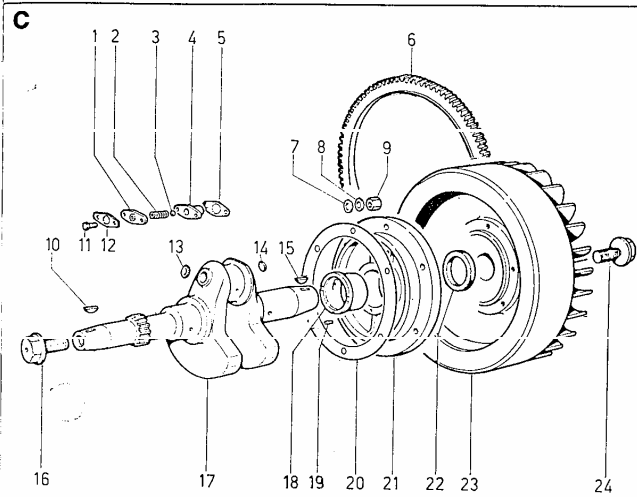

SERVICE

Per assistenza e ricambi rivolgersi a stazioni di servizio autorizzate Lombardini. N. tel. su libretto service e su pagine gialle.
 Pour toute exigence de service après vente et pièces détachées, s'adresser aux Stations de service du réseau Lombardini. N. de téléphone indiqué sur brochure relative au service après vente et annuaire catégorique.
 For spare parts and after sale assistance contact authorized Lombardini service centers. Tel. No. appears on service booklet and telephone directory.
 Für Service und Ersatzteile bitten wir, sich an autorisierte Werkstätte zu wenden. Telef. Nummer laut unserem Service - Büchlein und Fernsprechbuch.
 Para asistencia y repuestos, dirigirse a las estaciones de servicio autorizadas Lombardini. N. Tel. su libretto service y su hojas amarillas.
 Para assistência e recâmbios dirigir-se às estações de serviço autorizadas Lombardini. Número telefone é sobre a caderneta de serviço e sobre as páginas amarelas.

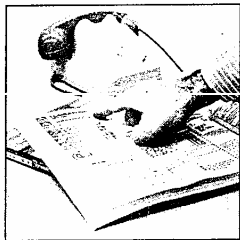
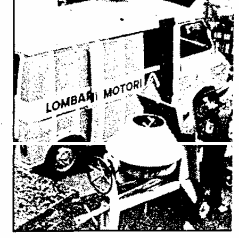
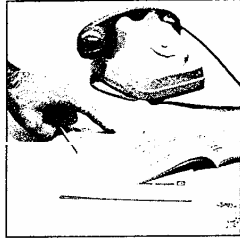
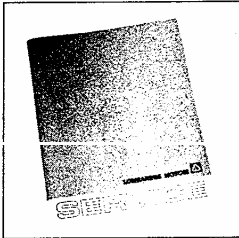

ORDINI RICAMBI
COMMANDES PIECES
PART ORDERS
E-TEIL BESTELLUNGEN
PEDIDOS DE REPUESTOS
PEDIDOS RECÂMBIOS

TIPO MOTORE
TYPE DE MOTEUR
ENGINE TYPE
MOTORTYP
TIPO DEL MOTOR
TIPO DE MOTOR

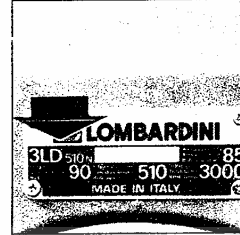
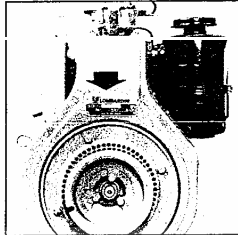

MATRICOLA
MATRICULE
SERIAL NUMBER
MOTORENNUMMER
NUMERO DEL MOTOR
NUMERO DO MOTOR

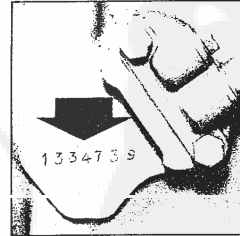
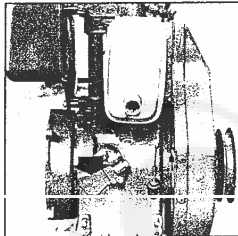
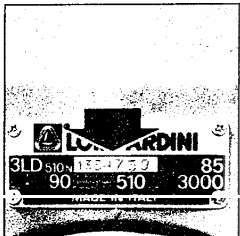
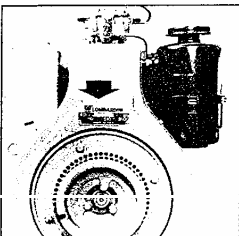

TIPO DELLA MACCHINA
TYPE DE MACHINE
EQUIPMENT TYPE
MASCHINENTYP
MODELO DE LA MAQUINA
TIPO DA MÁQUINA

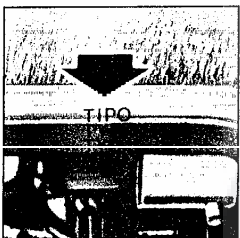
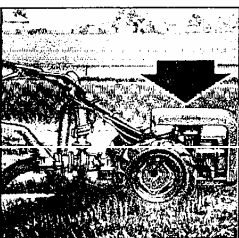

MATRICOLA del ricambio
REFERENCE de la pièce
SPARE PART number
BESTELLNUMMER des Teiles
REFERENCIA del repuesto
REFERÈNCIA do recâmbio

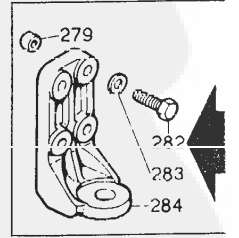
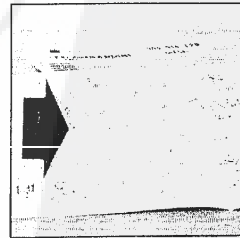

LOMBARDINI

FABBRICA ITALIANA MOTORI S.p.A.
 42100 REGGIO EMILIA, ITALIA - CAS. POST. 105 - Tel. (0522) 58011 - Telegr.: LOMBARMOTOR - Telex: 530003 MOTLOM I

BRIGGS & STRATTON -
 LOMBARDINI DIESEL INC.
 LOMBARDINI FRANCE
 LOMBARDINI MOTOREN
 LOMBARDINI MOTORES

3402 Oakliff Road B-2 Doraville, GA. 30340, USA
 Zone Industr. Nord Arnas - Villefranche S/Saône, France
 Genfer Str. II - 6 Frankfurt/Main 56, Deutschland
 Zona Cova Solera - Rubí/Barcelona, España

Matricola 1.5302.

Mod. 50539
7-1989
Subject to alteration
Printed in Italy



Gr. 4

-----	TAVOLA RICAMBI	MATR.
LEGENDA	SPARE PARTS TABLE	P.NO. ... 1.5302.316
-----	TABLEAU PIECES DETACHEES	REF.

Luglio/July/Juillet 1989

	MOTORI/ENGINES/MOTEURS	Gr. 4
Colonna/Column/Colonne 1	= 4LD 640	Versione/Version std. 710170
" " " 2	= 4LD 705	" " " 710390
" " " 3	= 4LD 820	" " " 710320

Vedi/See/Voir

Libretto Uso e Manutenzione	
Use-Maintenance booklet	1.5302.075
Livret Emploi-Entretien	
Libretto Service	
Service directory	1.7968.002
Reseau S.A.V.	
Serie accessori	
Accessory set	283.8140.080
Jeu accessoires	

note/remarks/remarques

- F - alta movimentazione/fast moving part/haut mouvement.
- S - media movimentazione/medium moving part/moyen mouvement.
- D - bassa movimentazione/slow moving part/bas mouvement.
- E - ad esaurimento/exhausting part/piece en epuisement.
- N - particolare nuovo o fornito su richiesta/
-new part or part supplied upon request/
-piece nouvelle ou fournie sur demande.
- A - valido dal motore.../from eng.S.No.../{ partir du moteur...
(vedi Circolare Tecnica/see Service Letter/voir Circ.Techn.)
- B - valido fino al motore.../up to eng.S.No.../jusqu'au moteur...
(vedi circolare tecnica/see Service Letter/voir circ.techn.)
- I - intercambiabile/interchangeable.
(vedi Circolare Tecnica/see Service Letter/voir Circ.Techn.)
- V - stock vitale per Officine Service.
vital stock for Service Dealer.
stock vital pour Stations Service.
- C - stock vitale per Costruttori, Esportatori, Enti di Stato.
vital stock for Producers, Exporters, State Companies.
stock vital pour Constructeurs, Export., Institut. de l'Etat.
- R - stock vitale per Rettifica.
vital stock for Grinding Workshops.
stock vital pour Usines de Rectification.
- 10/50/2-q.ta minima fornibile/min.supplied q.ty/q.te min.fournie.
- = gruppo completo/assembly/groupe complet.
- + componente del gruppo/assembly component/composant du groupe.

Serie guarnizioni/Gasket set	272.8180.024	4LD 640
	279.8180.027	4LD 705
	291.8180.038	4LD 820

Tipo motore/Engine type	Blocco motore/Short block
4LD 640 Industr.	2720.1560.033
4LD 705 Industr.	2790.1560.016
4LD 820 Industr.	2910.1560.049

TECO/ATL/Assistenza Tecnica Lombardini
DESCRIZIONI NON IMPEGNATIVE/SUBJECT TO MODIFICATIONS



ASPIRAZIONE E SCARICO/INTAKE AND EXHAUST

Pos.	Matricola/Part No.	Note/Remarks	Q. ty/Eng.		
A 1	=272.3700.139 FVIC	FILTRO ARIA/AIR CLEANER (Pos. 1-13-14-17-18-20-21)	1	1	1
A 2	9.3240.037 F 10	dado/nut	2	2	2
A 3	9.7555.008 FV C 10	rondella/washer	2	2	2
A 4	710.4501.003 FV C 50	guarnizione/gasket	2	2	2
A 5	710.4500.097 FV C 10	guarnizione/gasket	2	2	2
A 6	9.7625.019 S 10	rondella/washer	2	2	2
A 7	9.7565.011 F C 10	rondella/washer	2	2	2
A 8	9.3240.053 FV C 10	dado/nut	2	2	2
A 9	2790.2941.002 F C	curva/elbow			1
A 10	276.4500.079 FV C 10	guarnizione/gasket			1
A 11	9.1770.006 S 10	bullone/bolt M 8 X 1,25 X 25			2
A 12	9.7565.007 F C 10	rondella/washer			2
A 13+	292.5496.110 SVAC	massa filtrante/upper filtering elem.	1	1	1
A 14+	292.1261.073 DVAC 10	anello tenuta/seal ring diam.= 62,5	1	1	1
A 15	270.5460.090 F C	marmitta/muffler	1	1	
A 16	9.3240.019 FV C 10	dado/nut			2
A 17+	291.4776.032 FV C 10	guarnizione/gasket	1	1	1
A 18+	292.5496.111 FVIC	massa filtrante/filtering element	1	1	1
A 19	2830.5461.047 F C	marmitta/muffler			1
A 20+	276.4115.048 F C 10	gancio/hook	2	2	2
A 21+	vedi/see Pos. 1 ...			
A 22	2790.8545.040 D	staffa/brace			1
A 23	9.7625.020 D C 10	rondella/washer			2
A 24	9.1780.007 S 10	bullone/bolt M 10 X 1,5 X 35			1
A 25	9.1780.031 FV 10	bullone/bolt M 10 X 1,5 X 25			1
A 26	9.3240.033 FV 10	dado/nut			1
A 27	9.7565.011 F C 10	rondella/washer			1
A 28	2910.9170.028 F C	terminale/muffler end			1

Motore/Engine	4LD 640	Versione/Version	710170
"	4LD 705	"	710390
"	4LD 820	"	710320

LOMBARDINI MOTORI F.I.M. S.p.a.



CILINDRO, BIELLA E PISTONE/CYLINDER, CONNECTING ROD AND PISTON SET

Pos.	Matricola/Part No.	Note/Remarks	Q.ty/Eng.		
B 1	=272.6500.070 FV C	PISTONE COMPLETO/PISTON SET std.	1	1	1
"	=272.6500.071 F CR	" " +0,50	1	1	1
"	=272.6500.072 F CR	" " +1,00	1	1	1
"	=279.6501.021 FV C	" " std.	1	1	1
"	=279.6501.022 F CR	" " +0,50	1	1	1
"	=279.6501.023 F CR	" " +1,00	1	1	1
"	=291.6501.070 FV C	" " std.	1	1	1
"	=291.6501.071 F CR	" " +0,50	1	1	1
"	=291.6501.072 F CR	" " +1,00	1	1	1
		(Pos. 1-2-3-4)			
D 2:	270.8210.052 FV C 10	serie segm./ring set std.	1	1	1
"	276.8210.053 F CR10	" " +0,50	1	1	1
"	276.8210.054 F CR10	" " +1,00	1	1	1
"	279.8210.049 FV C 10	" " std.	1	1	1
"	279.8210.050 F CR10	" " +0,50	1	1	1
"	279.8210.051 F CR10	" " +1,00	1	1	1
"	291.8210.058 FV C 10	" " std.	1	1	1
"	291.8210.059 F CR10	" " +0,50	1	1	1
"	291.8210.060 F CR10	" " +1,00	1	1	1
B 3+	272.8480.010 F C	spinotto/gudgeon pin	1	1	1
"	279.8480.021 S C	" " "	1	1	1
"	291.8480.025 D C	" " "	1	1	1
B 4+	9.1240.026 FV C 10	anello seeger/snap ring	2	2	2
B 5	272.2380.010 FV C	cilindro/cylinder	1	1	1
"	279.2380.055 FV C	" " "	1	1	1
"	291.2380.082 FV C	" " "	1	1	1
B 6+	270.1630.006 FV CR10	bronz.piede biella/small end bearing	1	1	1
B 7	262.1640.024 FV C	br.biella/bearing std.	1	1	1
"	262.1640.025 FV CR10	" " -0,25	1	1	1
"	262.1640.026 FV CR10	" " -0,50	1	1	1
"	291.1640.045 FV C	" " std.	1	1	1
"	291.1640.048 F CR	" " -0,25	1	1	1
"	291.1640.049 F CR	" " -0,50	1	1	1
B 8	=270.1526.002 F C	BIELLA COMPLETA/CONNECTING ROD ASS.Y (Pos. 6-8-9-10)	1	1	1
B 9+	9.3203.034 FVIC 10	dado/nut	2	2	2
B 10+	270.1860.007 FV C 10	bullone/bolt	2	2	2
B 11	272.4410.061 D A 50	guarnizione/gasket	1	1	1
"	279.4410.062 D A 50	" " "	1	1	1
"	291.4410.063 D A 50	" " "	1	1	1

Motore/Engine	4LD 640	Versione/Version	710170
"	4LD 705	"	710390
"	4LD 820	"	710320

LOMBARDINI MOTORI F.I.M. S.p.a.



ALBERO A GOMITO, SUPPORTO E VOLANO/CRANKSHAFT, FLYWH.SIDE SUPPORT AND FLYWHEEL

Pos.	Matricola/Part No.	Note/Remarks	Q. ty/Eng.		
C 1+	vedi/see Pos. 4 ...			
C 2+	vedi/see Pos. 4 ...			
C 3+	9.8245.005 D C 10	sfera/ball	1	1	1
C 4	=273.9680.010 FV C	VALVOLA DI PRESSIONE/PRESSION VALVE (Pos. 1-2-3-4-5-11-12)	1	1	1
C 5+	271.4760.007 DV C 10	guarnizione/gasket	1	1	1
C 6	270.2816.011 F C	corona avviamento/crown gear			1
C 7	9.7565.011 F C 10	rondella/washer	6	6	6
C 8	9.7625.019 S 10	rondella/washer	6	6	6
C 9	9.3240.033 FV 10	dado/nut	6	6	6
C 10+	9.2280.049 FV 10	chiavetta/key	1	1	1
C 11+	9.1760.003 F 10	bullone/bolt M 6 X 1 X 12	2	2	2
C 12+	271.5110.084 D C 10	lamierino/tabwasher	1	1	1
C 13+	9.8990.019 S C 10	tappo/plug	1	1	1
C 14+	9.8990.002 F AC 10	tappo/plug	1	1	1
C 15+	9.2280.056 FV C 10	chiavetta/key	1	1	1
C 16	291.1862.012 S C	bullone/bolt	1	1	1
C 17	=272.1051.091 F IC	ALBERO A GOMITO/CRANKSHAFT	1	1	
"	=291.1051.092 F IC	" " " "			1
		(Pos. 10-13-14-15-17)			
C 18	272.1610.025 FV C	bronz. l.volano/flywh.side bear. std.	1	1	1
"	272.1610.057 FV CR10	" " " -0,50	1	1	1
"	272.1610.026 F CR	" " " -1,00	1	1	1
C 19	9.8430.055 S IC 10	spina/locking needle	1	1	1
C 20	270.4700.008 FV C 50	guarnizione/gasket 0,30	1	1	1
"	279.4700.074 N 50	" " " 0,10	1	1	1
C 21	270.8675.067 F C	supporto/support	1	1	1
C 22	9.1210.078 FV C 10	anello tenuta/seal ring std.	1	1	1
"	9.1210.083 FV CR10	" " " -1,00	1	1	1
C 23	270.3331.333 S C	volano/flywheel	1	1	1
C 24	270.1860.011 S C	bullone/bolt	1	1	1

Motore/Engine	4LD 640	Versione/Version	710170
"	4LD 705	"	710390
"	4LD 820	"	710320

LOMBARDINI MOTORI F.I.M. S.p.a.

DISTRIBUZIONE E REGOLATORE DI GIRI/TIMING AND SPEED GOVERNOR

Pos.	Matricola/Part No.	Note/Remarks	Q. ty/Eng.		
D 1+	9.1165.001 S	anello/circlip	1	1	1
D 2+	9.7625.074 N	rondella/washer	1	1	1
D 3	=270.4882.001 S C	FORCELLA COMPLETA/YOKE ASS.Y (Pos. 1-2-3-4-5-9-10-14-15-16-17-19-20-21-23-24)	1	1	1
D 3+	270.5199.008 S C	leva/lever	1	1	1
D 4+	270.5800.015 D C 10	molla/spring	1	1	1
D 5+	270.6231.037 D C 10	perno/pin	1	1	1
D 6	270.9520.023 S C	tubo prot./guard tube	1	1	1
D 7	292.4740.017 FV C 10	guarnizione/gasket	1	1	1
D 8	270.1410.011 FV C	asta punteria/push rod	2	2	2
D 9+	9.8420.012 D C 10	spina/locating pin	1	1	1
D 10+	270.6140.013 D C 10	perno/pin	1	1	1
D 11	270.4840.008 FV C	guida/guide	1	1	1
D 12	9.9730.028 F	vite/screw M 8 X 1,25 X 30	2	2	2
D 13	292.4740.017 FV C 10	guarnizione/gasket	1	1	1
D 14+	9.1755.004 D C 10	bullone/bolt M 5 X 0,8 X 18	1	1	1
D 15+	285.6330.061 D	piastrina/safety plate	1	1	1
D 16+	270.1557.021 D C 10	bloccetto/spacer	1	1	1
D 17+	270.5655.005 FV C 10	molla/spring	1	1	1
D 18	9.1760.012 D C 10	bullone/bolt M 6 X 1 X 35	1	1	1
D 19+	270.8615.020 D C	supporto/support	1	1	1
D 20+	9.1755.002 D	bullone/bolt M 5 X 0,8 X 12	1	1	1
D 21+	270.5655.005 FV C 10	molla/spring	1	1	1
D 22	9.8245.011 F C 10	sfera/ball	6	6	6
D 23+	270.3945.027 S C	forcella/yoke	1	1	1
D 24+	9.1165.006 D C 10	anello/circlip	1	1	1
D 25	9.9800.013 S C 10	vite/screw M 6 X 1 X 35	1	1	1
D 26	9.9732.092 F C 10	vite/screw M 8 X 1,25 X 18	1	1	1
D 27	270.4535.013 FV C 10	guarnizione/gasket	1	1	1
D 28	270.4535.013 FV C 10	guarnizione/gasket	1	1	1
D 29	270.5168.005 D C 10	lamierino/tabwasher	1	1	1
D 30	9.1750.035 S C 10	bullone/bolt M 4 X 0,7 X 12	2	2	2
D 31	270.6275.038 DV C 10	piastra/plate	1	1	1
D 32	270.6370.038 D C 10	piastrina/safety plate	1	1	1
D 33	9.1240.006 FV C 10	anello seeger/snap ring	1	1	1
D 34	270.7700.069 S C 10	rondella/washer	1	1	1
D 35	271.6130.016 S C	perno/governor shaft	1	1	1
D 36	9.7625.019 S	rondella/washer	1	1	1
D 37	9.3240.033 FV	dado/nut	1	1	1
D 38	270.4935.068 F C	ingranaggio/gearwheel	1	1	1
D 39	270.2085.029 F	campana regol./governor bell	1	1	1
D 40	9.1770.015 F	bullone/bolt M 8 X 1,25 X 55	1	1	1
D 41	9.7565.007 F C 10	rondella/washer	1	1	1
D 42	9.1240.013 D	anello seeger/snap ring	1	1	1
D 43	270.4330.028 F C	bilanc.pompa iniez./inj.pump rocker	1	1	1
D 44	271.6045.009 F C	perno/pin	1	1	1
D 45	270.4887.002 FV C	punteria/tappet	1	1	1
D 46	291.1010.060 F C	albero a camme/camshaft	1	1	1
D 47	270.4887.001 FV C	punteria/tappet	1	1	1

Motore/Engine	4LD 640	Versione/Version	710170
"	4LD 705	"	710390
"	4LD 820	"	710320

LOMBARDINI MOTORI F.I.M. S.p.a.



BASAMENTO, PORTINA LATO DISTRIBUZIONE E PIEDI/CRANKCASE, COVER GEAR AND MOUNTS

Pos.	Matricola/Part No.	Note/Remarks	Q.ty/Eng.		
E 1	=272.6646.091 D IC	PORTINA DISTR./GEAR SIDE CASE COVER (Pos. 1-9)	1	1	1
E 2	270.4431.004 SV C 50	guarnizione/gasket 0,40	1	1	1
E 3+	270.6850.024 SV C	prigioniero/stud	2	2	2
E 4+	270.6850.040 S C	prigioniero/stud	2	2	2
E 5	270.1610.009 FV C	bronz.1.distr./gear side bear. std.	1	1	1
"	270.1610.058 FV CR10	"	1	1	1
"	270.1610.010 F CR	" -0,50	1	1	1
E 6+	9.6800.059 D 10	" -1,00	1	1	1
E 7+	9.6800.018 D 10	prigioniero/stud M 10 X 30 (39)	1	1	1
E 8+	9.6800.010 S C 10	prigioniero/stud M 10 X 32 (47)	1	1	2
"	9.6800.010 S C 10	prigioniero/stud M 10 X 25 (40)	5	5	
E 9+	9.8990.008 S 10	prigioniero/stud M 10 X 25 (40)			3
E 10	9.3021.029 FVIC	tappo/plug	1	1	1
E 11+	9.8430.055 S IC 10	cuscinetto/ball bearing	1	1	1
E 12+	9.4670.060 FV C 10	spina/locking needle	1	1	1
E 13+	9.4670.058 FV C 10	guarnizione/copper gasket	1	1	1
E 14+	270.4730.021 SV C 10	guarnizione/copper gasket	1	1	1
E 15+	9.1770.001 FV 10	guarnizione/gasket	1	1	1
E 16+	9.8965.003 FV C 10	bullone/bolt M 8 X 1,25 X 12	1	1	1
"		tappo/plug	1	1	1
E 17	=270.3901.041 S C	FLANGIA OLIO/DIL FLANGE (Pos. 12-13-14-15-16-17-18)	1	1	1
E 18+	9.9732.064 S 10	vite/screw M 8 X 1,25 X 30	2	2	2
E 19	9.7565.011 F C 10	rondella/washer	8	8	8
E 20	9.1210.031 FV C 10	anello tenuta/seal ring	1	1	1
E 21	9.3240.033 FV 10	dado/nut	6	6	6
E 22	9.7565.011 F C 10	rondella/washer	6	6	6
E 23+	9.6800.053 S C 10	prigioniero/stud M 10 X 18 (33)	6	6	6
E 24	=272.1511.069 D IC	BASAMENTO COMPLETO/CRANKCASE ASS.Y	1		
"	=279.1511.081 S IC	"		1	
"	=291.1512.004 D IC	"			1
		(Pos. 3-4-6-7-8-11-12-13-14-15-16-17-18-23-24-25-26-27-28-29)			
E 25+	560.4580.047 FVIC 10	guarnizione/gasket 1,00	1	1	1
"	560.4580.049 FV C 10	" 0,50	1	1	1
"	560.4580.050 FV C 10	" 0,80	1	1	1
E 26+	255.6700.012 S C	portina/pan	1	1	1
E 27+	9.6780.012 DV C 10	prigioniero/stud M 8 X 25 (37)	2	2	2
E 28+	9.7555.007 DV C 10	rondella/washer	2	2	2
E 29+	9.3240.018 FV 10	dado/nut	2	2	2
E 30	270.6426.010 D C	piede/engine mount	2	2	2
E 31	9.1780.005 FV 10	bullone/bolt M 10 X 1,5 X 28	8	8	7

Motore/Engine	4LD 640	Versione/Version	710170
"	4LD 705	"	710390
"	4LD 820	"	710320

LOMBARDINI MOTORI F.I.M. S.p.a.

CIRCUITO COMBUSTIBILE/FUEL SYSTEM

Pos.	Matricola/Part No.	Note/Remarks	Q. ty/Eng.		
F 1	=285.9043.037 FV C	IAPPU SERBATOIO/TANK CAP (Pos.1-2)	1	1	1
F 2+	9.1200.015 FV C 10	anello tenuta/seal ring	1	1	1
F 3	=270.8101.018 F C	SERBATOIO COMPLETO/FUEL TANK (Pos. 1-2-3)	1	1	1
F 4	9.7565.007 F C 10	rondella/washer	2	2	2
F 5	9.1770.007 F C 10	bullone/bolt	2	2	2
F 6	260.5390.006 S C 10	manicotto/rubber sheathing	1	1	1
F 7	9.7565.007 F C 10	rondella/washer	1	1	1
F 8	9.1770.042 D C 10	bullone/bolt	1	1	1
F 9+	260.1570.016 DV C	bocchettone/filler cap	1	1	1
F 10+	260.4130.053 SV C	ghiera/ring nut	1	1	1
F 11	9.4670.058 FV C 10	guarnizione/copper gasket	2	2	2
F 12+	9.1901.029 FVIC 10	bullone raccordo/connection bolt	1	1	1
F 13+	271.7265.008 FV C 10	raccordo/connection	1	1	1
F 14	2830.3617.016 S C 10	fascetta/strip fixing	1	1	1
F 15	270.9370.009 FV C	tubo comb./fuel pipe	1	1	1
F 16+	260.4370.007 DV C 10	guarnizione/gasket	1	1	1
F 17:	260.6010.002 DV C	sede/seat	1	1	1
F 18+	260.5800.038 SV C	molla/spring	1	1	1
F 19+	283.6578.013 FV C	pompante/injection plunger	1	1	1
F 20+	273.9672.013 F C	valvolina mandata/delivery valve	1	1	1
F 21+	9.1200.031 FV C 10	anello OR/rubber oil seal	1	1	1
F 22+	271.8335.029 SV C 10	spessore/shim	1	1	1
F 23+	271.7470.003 FV C 10	riempitore/filler	1	1	1
F 24+	271.5755.034 SV C 10	molla/spring	1	1	1
F 25	270.9570.067 FV C 10	tubo spurgo in./bleeding pipe	1	1	1
F 26+	500.7301.006 D I	raccordo/connection	1	1	1
F 27+	260.4650.037 DV C 10	guarnizione/gasket	1	1	1
F 28+	260.1420.012 DV C	asta comando/control rod	1	1	1
F 29	9.3240.095 FV C 10	dado/nut	2	2	2
F 30+	273.5575.006 FV C 10	molla/spring	1	1	1
F 31+	273.3930.019 F C 10	fondello/cup	1	1	1
F 32+	9.1200.032 FV C 10	anello OR/rubber oil seal	1	1	1
F 33	9.4670.060 FV C 10	guarnizione/copper gasket	1	1	1
F 34+	271.4760.015 FV C 10	guarnizione/gasket	1	1	1
F 35	9.4670.060 FV C 10	guarnizione/copper gasket	1	1	1
F 36	9.1901.031 FVIC 10	bullone raccordo/connection bolt	1	1	1
F 37	9.4775.196 SV C 10	guarnizione/gasket	1	1	1
F 38	9.9080.037 FV C 10	tappo/deaeration cap	1	1	1
F 39	=291.6615.015 F C	PORTAPOLVERIZZATORE/NOZZLE-HOLDER (Pos. 9-10-12-16-17-18-26-27-28-39-40-41)	1	1	1
F 40+	710.6531.265 FVIC	polverizzatore/nozzle	1	1	1
F 41+	260.4130.052 SV C	ghiera/ring nut	1	1	1
F 42+	9.6780.018 FV C 10	prigioniero/stud M 8 X 28 (43)	2	2	2
F 43	=273.3730.015 FV C	FILTRO COMBUSTIBILE/FUEL FILTER (Pos. 30-31-32-43-44-45-61-62-63)	1	1	1
F 43+	273.2175.009 FV C	cartuccia comb./f.filter element	1	1	1
F 44+	273.4490.017 FV C 10	guarnizione/gasket	1	1	1
F 45+	260.4430.071 FV C 10	guarnizione/gasket	1	1	1
F 46	9.3240.018 FV 10	dado/nut	2	2	2
F 47	9.7565.007 F C 10	rondella/washer	2	2	2
F 48	9.7625.012 FV C 10	rondella/washer	2	2	2
F 49	270.3525.093 S C 10	distanziale/spacer	2	2	2
F 50	9.1770.011 S C 10	bullone/bolt M 8 X 1,25 X 40	2	2	2
F 51	9.9732.074 S C 10	vite/screw M 8 X 1.25 X 20	3	3	3
F 52+	270.1415.007 DV C	asta comando/control rod	1	1	1
F 53+	277.6230.075 S 10	perno/pin	1	1	1
F 54	270.1580.016 F C 10	boccola/bushing	1	1	1
F 55	9.7626.017 N 10	rondella/washer	1	1	1
F 56	9.4670.009 FV C 10	guarnizione/copper gasket 0,50	1	1	1
"	9.4670.010 FV C 10	" " 1,00	1	1	1
"	9.4670.011 FV C 10	" " 1,50	1	1	1
F 57+	260.7980.020 SV C	scodellino/cup	1	1	1
F 58+	260.4850.009 FV C	guida/guide	1	1	1

Motore/Engine	4LD 640	Versione/Version	710170
"	4LD 705	"	710390
"	4LD 820	"	710320

LOMBARDINI MOTORI F.I.M. S.p.a.



Segue riquadro/Continues F

Pos.	Matricola/Part No.	Note/Remarks	Q. ty/Eng.		
F 59	=283.6590.033 F C	POMPA INIEZIONE/INJECTION PUMP (Pos. 13-19-20-21-22-23-24-34-52-53-57-58-59-50-66-67-68-69-70-71-73)	1	1	1
F 60+	9.1260.084 DV C 10	anello/ring	1	1	1
F 61+	273.2605.033 F AC	coperchio/filter cover	1	1	1
F 62+	9.1760.076 D A	bullone/bolt	1	1	1
F 63+	9.1202.052 FVAC 10	anello OR/rubber oil seal	1	1	1
F 64	9.3630.008 F C 10	fascetta/clamp	1	1	1
F 65	273.9375.274 FVAC	tubo da serb. lato dist. a pompa in.	1	1	1
F 66+	260.5625.002 SV C	molla/spring	1	1	1
F 67+	260.6400.024 D	piattello/retainer	1	1	1
F 68+	260.7770.020 SV C	rullo/roller	1	1	1
F 69+	260.1970.054 DV C	bussola/sleeve	1	1	1
F 70+	260.6230.068 SV C	perno/pin	1	1	1
F 71+	260.7215.017 FV C	punteria/tappet	1	1	1
F 72	283.4580.001 D 50	guarnizione/gasket 0,10	1	1	1
"	283.4580.008 N 50	" " 0,50	1	1	1
"	283.4580.012 N 50	" " 0,30	1	1	1
"	283.4580.039 N 10	" " 0,05	1	1	1
F 73+	260.6230.069 DV C	perno/pin	1	1	1
F 74	9.2800.003 F C 10	copiglia/cotter pin	1	1	1

Motore/Engine	4LD 640	Versione/Version	710170
"	4LD 705	"	710390
"	4LD 820	"	710320

LOMBARDINI MOTORI F.I.M. S.p.a.

COPIATO DATA 11/1989



RAFFREDDAMENTO/COOLING SYSTEM

Pos.	Matricola/Part No.	Note/Remarks	Q. ty/Eng.		
G 1	270.5065.009 F C	lamiera/airtight plate	1	1	1
G 2	9.1760.003 F 10	bullone/bolt M 6 X 1 X 12	4	4	4
G 3	9.7565.004 F C 10	rondella/washer	4	4	4
G 4	9.7625.007 S C 10	rondella/washer	4	4	4
G 5	9.3240.008 FV 10	dado/nut	3	3	3
G 6	270.2565.076 F IC	convogliatore/shroud	1	1	
G 7	9.3203.059 N 10	dado/nut			2
G 8	9.6820.014 D 10	prigioniero/stud M 12 X 30 (48)			2
G 9	9.7625.026 S 10	rondella/washer			2
G 10	291.6371.039 F C	piastra/shroud plate			1
G 11	270.2565.070 F C	convogliatore/shroud			1
G 12	2/0.9245.025 S L 10	tirante/tie rod	1	1	1
G 13	9.7625.005 FV C 10	rondella/washer	1	1	1
G 14	9.3240.003 FV C 10	dado/nut	1	1	1
G 15	9.3240.003 FV C 10	dado/nut	1	1	1
G 16	270.5065.012 F C	lamiera/airtight plate	1	1	1
G 17	270.5095.057 F C	lamiera/panel guard	1	1	
"	291.5095.081 S C	lamiera/panel			1
G 18	9.7540.006 D C 10	rondella/washer	4	4	4
G 19	9.9810.012 S 10	vite/screw	4	4	4
G 20	270.6685.045 S	portina/cover			1
G 21	422.4775.042 N 50	guarnizione/gasket			1
G 22	271.7500.018 SV C 10	rondella/washer			7
G 23	9.1755.001 FV 10	bullone/bolt M 5 X 0,8 X 8			7

Motore/Engine	4LD 640	Versione/Version	710170
"	4LD 705	"	710390
"	4LD 820	"	710320



CIRCUITO DI LUBRIFICAZIONE/LUBRICATING SYSTEM

Pos.	Matricola/Part No.	Note/Remarks	Q. ty/Eng.		
H 1+	9.9765.001 S C 10	vite/screw M 6 X 1 X 8	1	1	1
H 2	9.9730.030 S C 10	vite/screw M 8 X 1,25 X 35	2	2	2
H 3	9.7625.010 FV C 10	rondella/washer	2	2	2
H 4	=272.4336.023 F IC	POMPA OLIO/LUBR.OIL PUMP ASS.Y (Pos. 1-4-5-6)	1	1	1
H 5+	vedi/see Pos. 4 ...			
H 6+	vedi/see Pos. 4 ...			
H 7	270.1400.005 F C 10	asta liv./dipstick	1	1	1
H 8	270.7700.014 N 10	rondella/washer	1	1	1
H 9	270.9320.046 S C	tubo/pipe	1	1	1
H 10	9.9730.010 S 10	vite/screw M 6 X 1 X 16	2	2	2
H 11	9.3203.014 FV C 10	dado/nut	1	1	1
H 12	9.7625.010 FV C 10	rondella/washer	1	1	1
H 13	272.4975.018 F IC	ingranaggio/gearwheel	1	1	1
H 14	9.9730.015 F C 10	vite/screw M 6 X 1 X 30	1	1	1
H 15	9.7565.004 F C 10	rondella/washer	1	1	1
H 16	9.7625.007 S C 10	rondella/washer	1	1	1
H 17	9.7625.010 FV C 10	rondella/washer	1	1	1
H 18	9.1770.002 FV 10	bullone/bolt M 8 X 1,25 X 16	10	10	10
H 19	270.6645.040 S C	portina/oil pan	1	1	1
H 20	270.4600.091 FV C 10	guarnizione/gasket	1	1	1
H 21	9.4670.016 FV C 10	guarnizione/copper gasket	1	1	1
H 22	9.8965.005 FV C 10	tappo/oil drain plug	1	1	1

Motore/Engine	4LD 640	Versione/Version	710170
"	4LD 705	"	710390
"	4LD 820	"	710320

LOMBARDINI MOTORI F.I.M. S.p.a.



COMANDI/CONTROLS

Pos.	Matricola/Part No.	Note/Remarks	Q.ty/Eng.		
I 1+	283.5200.159 F AC 10	leva/lever	1	1	1
I 2+	9.8420.001 D C 10	spina/locating pin	1	1	1
I 3+	vedi/see Pos. 5 ...			
I 4+	9.1200.041 FV 10	anello OR/rubber oil seal	1	1	1
I 5	=272.2516.045 F IC	COMANDO SUPPLEMENTO/DEVICE CONTROL (Pos. 2-3-4-5-7-8)	1	1	1
I 6+	270.4700.070 N 50	guarnizione/gasket 0,25	1	1	1
I 7+	270.5550.007 SV C 10	molla/spring	1	1	1
I 8+	vedi/see Pos. 5 ...			
I 9+	9.1165.001 S 10	anello/circlip	1	1	1
I 10+	9.3240.004 FV C 10	dado/nut	1	1	1
I 11+	90.6330.057 F C 10	piastrina/safety plate	1	1	1
I 12+	9.7625.019 S 10	rondella/washer	1	1	1
I 13+	272.9820.109 D AC 10	vite/fixing screw	1	1	1
I 14+	9.7625.007 S C 10	rondella/washer	1	1	1
I 15	9.1760.005 FV 10	bullone/bolt M 6 X 1 X 16	2	2	2
I 16+	270.9245.031 S C 10	tirante/tie rod	1	1	1
I 17	9.7625.059 D C 10	rondella/washer	2	2	2
I 18+	vedi/see Pos. 37 ...			
I 19+	272.5200.254 D AC	leva/lever	1	1	1
I 20+	272.7865.088 D AC	scatola comando/control housing	1	1	1
I 21+	9.3240.008 FV 10	dado/nut	1	1	1
I 22+	9.1760.029 D A 10	bullone/bolt M 6 X 1 X 30	1	1	1
I 23+	9.3240.008 FV 10	dado/nut	1	1	1
I 24+	9.1760.029 D C 10	bullone/bolt M 6 X 1 X 30	1	1	1
I 25+	9.3200.015 FVIC 10	dado/nut	1	1	1
I 26+	9.7626.054 S AC 10	rondella/washer	2	2	2
I 27+	9.9790.037 FV C 10	vite/screw M 6 X 1 X 8	2	2	2
I 28	=275.2515.029 F C	COMANDO ACCELERATORE/THROTTLE CONTROL (Pos. 1-9-10-11-12-13-14-16-18-19-20- 21-22-23-24-25-26-27-28-29-30-31-32- 33-35-37)	1	1	1
I 28+	283.2690.122 F AC 10	coperchio/cover	1	1	1
I 29+	283.6370.114 S AC 10	piastra/plate	1	1	1
I 30+	270.5680.025 SV C 10	molla/spring	1	1	1
I 31+	9.1200.041 FV 10	anello OR/rubber oil seal	1	1	1
I 32+	9.1770.042 D C 10	bullone/bolt M 8 X 1,25 X 10	1	1	1
I 33+	9.7555.007 DV C 10	rondella/washer	1	1	1
I 34	9.9800.061 F C 10	vite/screw M 6 X 1 X 16	3	3	3
I 35+	9.8420.012 D C 10	spina/locating pin	1	1	1
I 36	270.4700.069 N 50	guarnizione/gasket	1	1	1
I 37	=283.5200.292 S C	LEVA COMPLETA/LEVER ASS.Y (Pos. 18-35-37)	1	1	1

Motore/Engine	4LD 640	Versione/Version	710170
"	4LD 705	"	710390
"	4LD 820	"	710320



TESTA, CAPPELLO BILANCIERI E VALVOLE/CYLINDER HEAD, ROCKER ARM BOX AND VALVES

Pos.	Matricola/Part No.	Note/Remarks	Q.ty/Eng.		
L 1	=272.2125.083 S IC	COOPERCHIO BILANC./ROCKER BOX CAP (Pos. 1-6-7)	1	1	1
L 2+	9.1200.014 FVIC 10	anello OR/rubber oil seal	1	1	1
L 3	=530.9050.050 FVIC	TAPPO SFIATO/BREATHING CAP (Pos. 2-3)	1	1	1
L 4	270.9055.003 FV C 10	tappo/starter cap	1	1	1
L 5	500.3695.038 F C 10	filo/wire	1	1	1
L 6+	904.8506.003 S AC 10	squadretta/angle bracket	1	1	1
L 7+	9732.062 S AC 10	vite/screw M 6 X 1,25 X 35	2	2	2
L 8+	270.9850.002 F C 10	vite/screw	1	1	1
L 9+	9.3240.010 FV C 10	dado/nut	1	1	1
L 10	=291.4330.023 F C	GRUPPO BILANC./ROCKER ARM ASS.Y (Pos. 8-9-10-11-12-13-14-15-23)	1	1	1
L 11+	291.6045.029 FV C 10	perno bil./rocker shaft	1	1	1
L 12+	9.9765.051 F C 10	vite/screw M 6 X 1 X 8	1	1	1
L 13+	270.9850.002 F C 10	vite/screw	1	1	1
L 14+	9.3240.010 FV C 10	dado/nut	1	1	1
L 15+	vedi/see Pos. 10 ...	1	1	1
L 16+	9.6800.050 S I 10	prigioniero/stud M 10 X 23 (38)	2	2	2
L 17	270.4400.007 FV C 50	guarnizione/gasket 0,50	1	1	1
L 18+	291.1160.013 FV C 10	anello/circlip	1	1	1
L 19+	291.4845.158 FVICR10	guida v.aspir./inlet v.guide std.	1	1	1
"	291.4845.159 FVICR10	guida v.aspir./inlet v.guide +0,50	1	1	1
L 20+	291.4845.160 FVACR10	guida v.scar./exhaust v.guide std.	1	1	1
"	291.4845.161 FVACR10	guida v.scar./exhaust v.guide +0,50	1	1	1
L 21+	291.1160.013 FV C 10	anello/circlip	1	1	1
L 22	270.3206.015 FV C 10	dado/nut	4	4	4
L 23+	9.1200.027 FV C 10	anello OR/rubber oil seal	1	1	1
L 24	9.7625.197 N 10	rondella/washer	4	4	4
L 25+	270.2135.067 FV C 10	cappellotto/cap	1	1	1
L 26+	260.6410.018 F C 10	piattello/retainer with half-collets	2	2	2
L 27	=291.9201.003 F C	TESTA COMPLETA/CYLINDER HEAD ASS.Y (Pos. 8-9-10-11-12-13-14-15-16-18-19- 20-21-23-25-26-27-29-30-31-32-33-34- 35-36-F 42)	1	1	1
L 27	=291.9201.004 F C	TESTA SEMICOMPLETA/CYLINDER HAED (Pos. 16-18-19-20-21-27-29-30-31- F 42)	1	1	1
L 28+	272.4730.107 SVAC 10	guarnizione/head gasket 0,70	1	1	1
"	272.4730.108 SVAC 10	" " 0,80	1	1	1
"	272.4730.109 DVAC 10	" " 0,90	1	1	1
"	272.4730.110 DVAC 10	" " 1,00	1	1	1
"	272.4730.111 DVAC 10	" " 1,10	1	1	1
"	279.4730.112 S A 50	" " 0,70	1	1	1
"	279.4730.113 S A 50	" " 0,80	1	1	1
"	279.4730.114 S A 50	" " 0,90	1	1	1
"	279.4730.115 S A 50	" " 1,00	1	1	1
"	279.4730.116 S A 50	" " 1,10	1	1	1
L 29+	291.8000.046 FV CR10	sede v.aspirazione/inlet v.seat	1	1	1
L 30+	291.8000.047 FV CR10	sede v.scarico/exhaust v.seat	1	1	1
L 31+	9.6800.050 S I 10	prigioniero/stud M 10 X 23 (38)	2	2	2
L 32+	9.8990.017 F C 10	tappo/plug	1	1	1
L 33+	291.6410.037 F IC 10	piattello/retainer	2	2	2
L 34+	291.9652.019 FV CR10	valvola aspirazione/inlet valve	1	1	1
L 35+	291.9685.031 FV CR10	valvola scarico/exhaust valve	1	1	1
L 36+	260.5755.004 FV C	molla/spring	2	2	2

Motore/Engine	4LD 640	versione/version	710170
"	4LD 705	"	710390
"	4LD 820	"	710320

LOMBARDINI MOTORI F.I.M. S.p.a.



AVVIAMENTO/STARTING

Pos.	Matricola/Part No.	Note/Remarks	Q.ty/Eng.		
M 1	270.6960.061 FV C	puleggia avv./st.pulley	1	1	1
M 2	9.7555.007 DV C 10	rondella/washer	6	6	6
M 3	9.1770.006 S 10	bullone/bolt M 8 X 1,25 X 25	6	6	6
M 4	283.4055.003 F C	fune avviamento/rope starting	1	1	1

Motore/Engine	4LD 640	Versione/Version	710170
"	4LD 705	"	710390
"	4LD 820	"	710320

PUBBLICAZIONE DATA 11/11/88

LOMBARDINI MOTORI F.I.M. S.p.a.



COMPOSIZIONE SERIE GUARNIZIONI/GASKET SET COMPOSITION

Pos.	Matricola/Part No.	Note/Remarks	Q. ty/Eng.		
xxx	=272.8180.024 FV CR	SERIE GUARNIZIONI/GASKET SET	1		
"	=279.8180.027 FV CR	"		1	
"	=291.8180.038 FV CR	"			1
A 4	710.4501.003 FV C 50	guarnizione/gasket	2	2	2
A 5	710.4500.097 FV C 10	guarnizione/gasket	2	2	2
A 10	276.4500.079 FV C 10	guarnizione/gasket			1
B 11	272.4410.061 D A 50	guarnizione/gasket	1		
"	279.4410.062 D A 50	"		1	
"	291.4410.063 D A 50	"			1
C 5	271.4760.007 DV C 10	guarnizione/gasket	1	1	1
C 20	270.4700.008 FV C 50	guarnizione/gasket	1	1	1
"	279.4700.074 N 50	" 0,30	1	1	1
"		" 0,10	1	1	1
D 27	270.4535.013 FV C 10	guarnizione/gasket	1	1	1
D 28	270.4535.013 FV C 10	guarnizione/gasket	1	1	1
E 2	270.4431.004 SV C 50	guarnizione/gasket 0,40	2	2	2
E 14	270.4730.021 SV C 10	guarnizione/gasket	1	1	1
E 25	560.4580.047 FVIC 10	guarnizione/gasket 1,00	1	1	1
F 72	283.4580.001 D 50	guarnizione/gasket 0,10	1	1	1
"	283.4580.008 N 50	" 0,50	1	1	1
"	283.4580.012 N 50	" 0,30	1	1	1
H 20	270.4600.091 FV C 10	guarnizione/gasket	1	1	1
I 6	270.4700.070 N 50	guarnizione/gasket 0,25	1	1	1
I 36	270.4700.069 N 50	guarnizione/gasket	1	1	1
L 17	270.4400.007 FV C 50	guarnizione/gasket 0,50	1	1	1
L 28	272.4730.108 SVAC 10	" 0,80	1		
"	272.4730.109 DVAC 10	" 0,90	1		
"	279.4730.113 S A 50	" 0,80		1	1
"	279.4730.114 S A 50	" 0,90		1	1

Motore/Engine	4LD 640	Versione/Version	710170
"	4LD 705	"	710390
"	4LD 820	"	710320

LOMBARDINI MOTORI F.I.M. S.p.a.

P. 1030 2011 1.1.1

INDICE DELLE MODIFICHE/IMPROVEMENTS INDEX

Motori/Engines Gr. 4



Pos.	Nuova matricola New Part No.	Vecchia matricola Old Part.No.	Vedi Circ.Tec. See Serv.Lett.	Q. ty/Eng.		
A 1	=272.3700.139 FVIC	272.3702.026	1250	1	1	1
A 13	292.5496.110 SVAC	1250	1	1	1
A 14	292.1261.073 DVAC 10	270.3525.080	1250	1	1	1
A 18	292.5496.111 FVIC	272.5496.052	1250	1	1	1
B 9	9.3203.034 FVIC 10	9.3240.032	1245	2	2	2
B 11	272.4410.061 D A 50	272.4410.008	1243	1		
"	279.4410.062 D A 50	279.4410.023	1240		1	
"	291.4410.063 D A 50	291.4410.037	1242			1
C 14	9.8990.002 F AC 10	9.8990.019	1241	1	1	1
C 17	=272.1051.001 F IC	270.1050.007	1222	1	1	
"	=291.1051.092 F IC	291.1051.011	1232			1
C 19	9.8430.055 S IC 10	270.8460.054	5153	1	1	1
E 1	=272.6646.091 D IC	270.6645.068	1232	1	1	1
E 10	9.3021.029 FVIC	271.1710.032	1232	1	1	1
E 11	9.8430.055 S IC 10	270.8460.054	5153	1	1	1
E 24	=272.1511.069 D IC	272.1511.063	5153	1		
"	=279.1511.081 S IC	279.1511.075	5153		1	
"	=291.1512.004 D IC	291.1511.096	5153			1
E 25	560.4580.047 FVIC 10	272.4580.006	5153	1	1	1
F 12	9.1901.029 FVIC 10	9.1900.002	5153	1	1	1
F 26	500.7301.006 D I	260.7300.035	5153	1	1	1
F 36	9.1901.031 FVIC 10	9.1900.067	5153	1	1	1
F 40	710.6531.265 FVIC	710.6531.033	5153	1	1	1
F 61	273.2605.033 F AC	273.2605.023	1248	1	1	1
F 62	9.1760.076 D A	9.1760.006	5007	1	1	1
F 63	9.1202.052 FVAC 10	9.4670.001	5007	1	1	1
F 65	273.9375.274 FVAC	2830.9371.071	1248	1	1	1
G 6	270.2565.076 F IC	6035.2566.071	5153	1	1	
H 4	=272.4336.023 F IC	270.6605.003	5153	1	1	1
H 13	272.4975.018 F IC	272.4975.003	5153	1	1	1
T 1	283.5200.159 F AC 10	270.5200.088	1236	1	1	1
I 5	=272.2516.045 F IC	271.4875.002	5153	1	1	1
I 13	272.9820.109 D AC 10	270.9820.073	1244	1	1	1
I 19	272.5200.254 D AC	270.5200.086	1244	1	1	1
I 20	272.7865.088 D AC	270.7865.018	1244	1	1	1
I 22	9.1760.029 D A 10	9.1760.082	1244	1	1	1
I 25	9.3200.015 FVIC 10	9.3200.001	1236	1	1	1
I 26	9.7626.054 S AC 10	9.7625.005	1236	2	2	2
I 28	283.2690.122 F AC 10	270.2690.043	1236	1	1	1
I 29	283.6370.114 S AC 10	270.6140.071	1236	1	1	1
L 1	=272.2125.083 S IC	270.2125.024	596	1	1	1
L 2	9.1200.014 FVIC 10	9.1200.040	5153	1	1	1
L 3	=530.9050.050 FVIC	270.9050.021	5153	1	1	1
L 6	904.8506.003 S AC 10	270.4260.003	596	1	1	1
L 7	9.9732.063 S AC 10	9.1770.007	596	2	2	2
L 16	9.6800.050 S I 10	9.6800.051	5153	2	2	2
L 19	291.4845.158 FVICR10	291.4845.054	1254	1	1	1
"	291.4845.159 FVICR10	291.4845.060	1254	1	1	1
L 20	291.4845.160 FVACR10	291.4845.055	1255	1	1	1
"	291.4845.161 FVACR10	291.4845.061	1255	1	1	1
L 28	272.4730.107 SVAC 10	1243	1		
"	272.4730.108 SVAC 10	1243	1		
"	272.4730.109 DVAC 10	1243	1		
"	272.4730.110 DVAC 10	1243	1		
"	272.4730.111 DVAC 10	1243	1		
"	279.4730.112 S A 50	1240, 1242		1	1
"	279.4730.113 S A 50	1240, 1242		1	1
"	279.4730.114 S A 50	1240, 1242		1	1
"	279.4730.115 S A 50	1240, 1242		1	1
"	279.4730.116 S A 50	1240, 1242		1	1
L 31	9.6800.050 S I 10	9.6800.051	5153	2	2	2
L 33	291.6410.037 F IC 10	1220	2	2	2

Motore/Engine	4LD 640	Versione/Version	710170
"	4LD 705	"	710390
"	4LD 820	"	710320

LOMBARDINI MOTORI F.I.M. S.p.a.

