

**TAVOLA RICAMBI
TABLEAU PIECES DETACHEES
SPARE PARTS TABLE
ERSATZTEILTAFEL
TABLA DE REPUESTOS
TÁBUA PEÇAS DE TROCA**

**5LD675-3
5LD824-3/B
5LD825-3
5LD930-3**

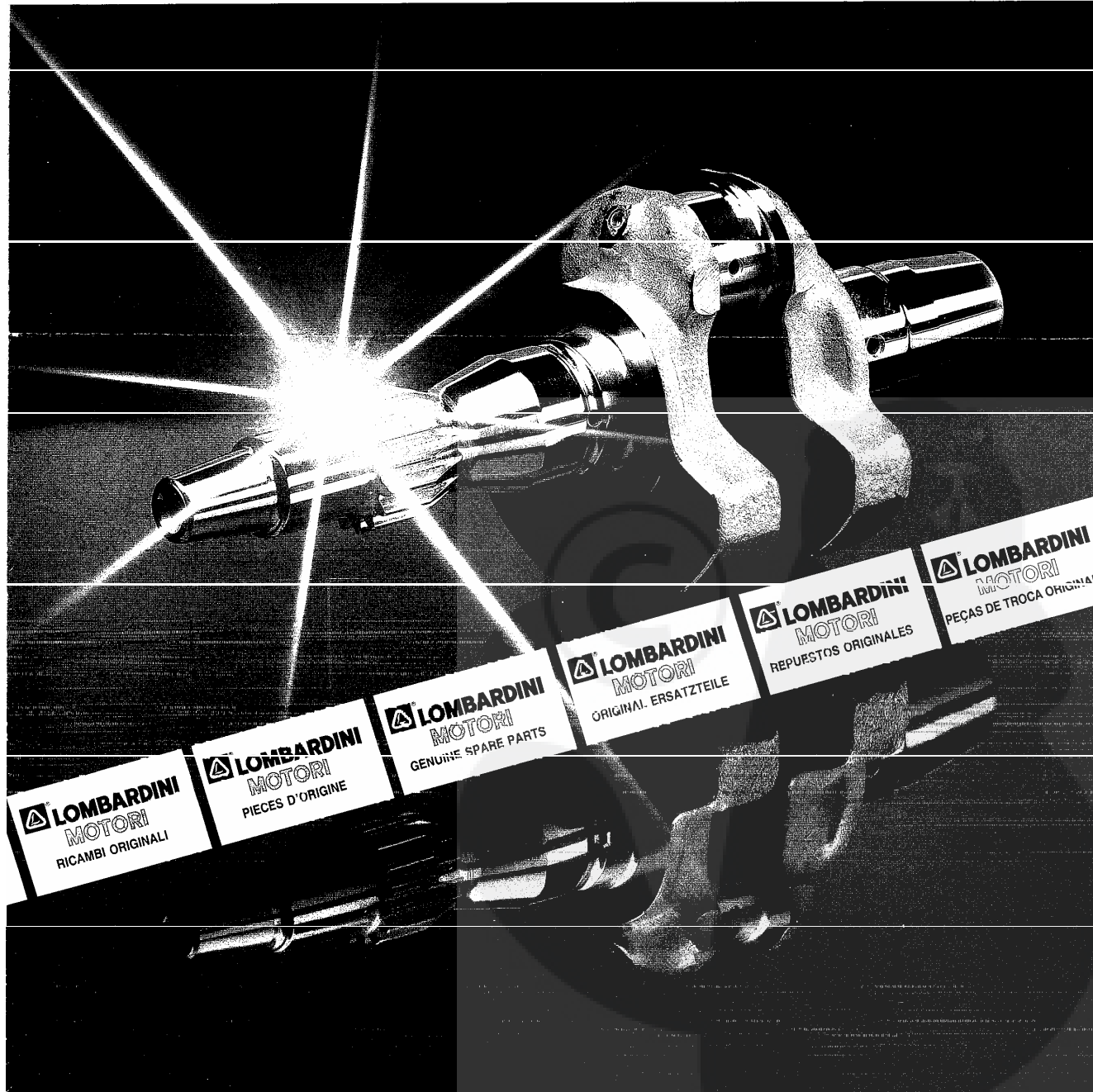

RICAMBI
PIECES
SPARE PARTS
ERSATZTEILE
REPLACEMENTS
RECAMBIOS

RICAMBI PER MOTORE STANDARD.
PER APPLICAZIONI SPECIALI
CONSULTARE IL CATALOGO PRESSO I
CENTRI ASSISTENZA E RICAMBI.

PIECES POUR DES MOTEURS
STANDARD.
POUR LES ADAPTATIONS CONSULTER
LE CATALOGUE AUPRES DES AGENTS
SERVICE.

SPARE PARTS FOR STANDARD
ENGINE.
FOR SPECIAL APPLICATIONS SEE
MASTER CATALOG AT SERVICE
CENTERS.

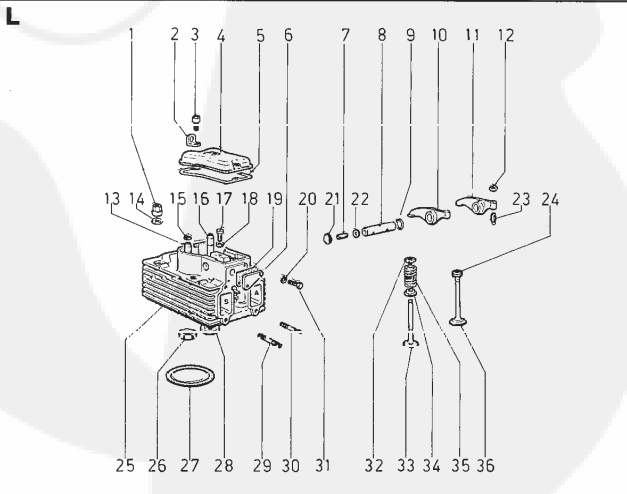
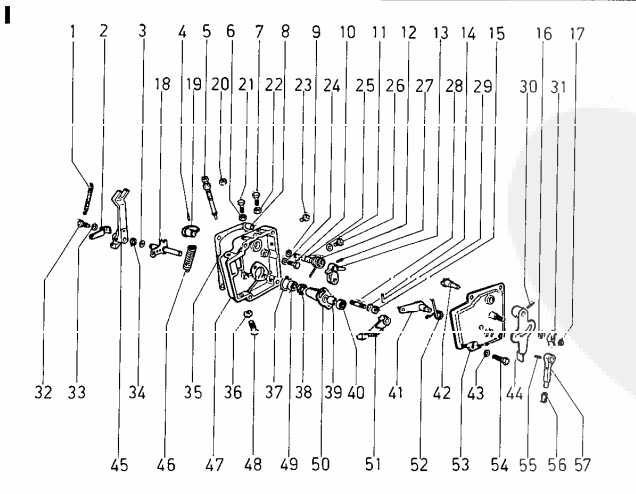
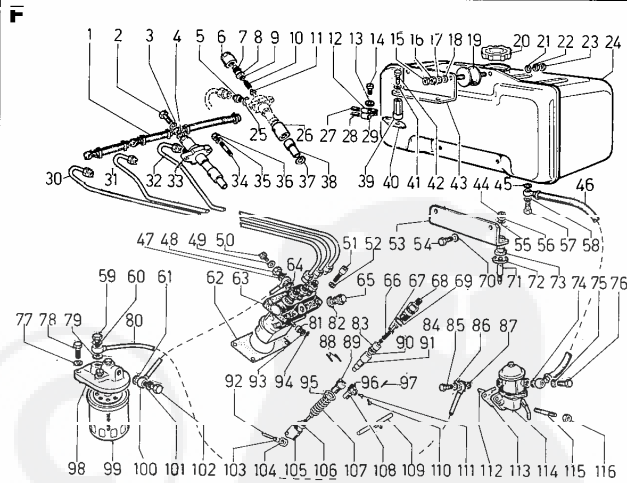
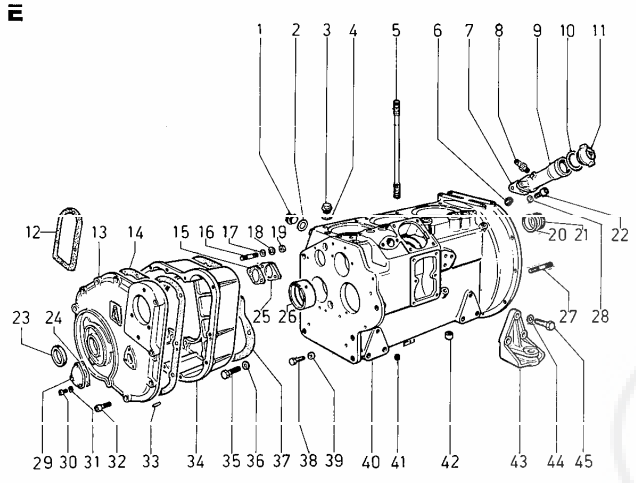
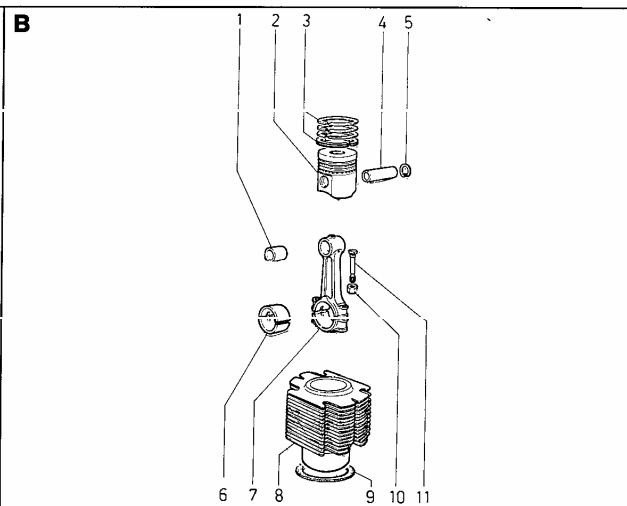
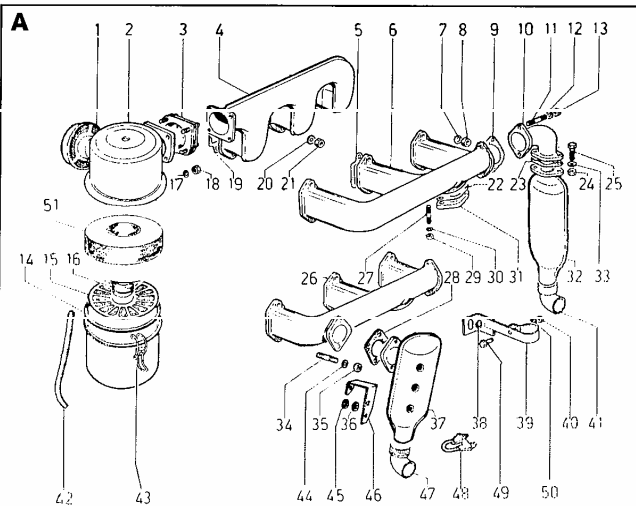

ERSATZTEILE FÜR STANDARD-MOTOREN.
FÜR SONDERANFERTIGUNGEN SIEHE
ERSATZTEILKATALOG BEI SERVICE
WERKSTÄTTEN.

REPUESTOS PARA MOTORES
STANDARD.
PARA APLICACIONES VEASE
CATALOGO EN LAS ESTACIONES
SERVICE.

PEÇAS DE TROCA PARA MOTOR
STANDARD.
PARA APLICAÇÕES ESPECIAIS
CONSULTAR O CATÁLOGO NOS
CENTROS DE ASSISTÊNCIA E PEÇAS
DE TROCA.

GRUPPO

5/3

Matricola 1.5302.421

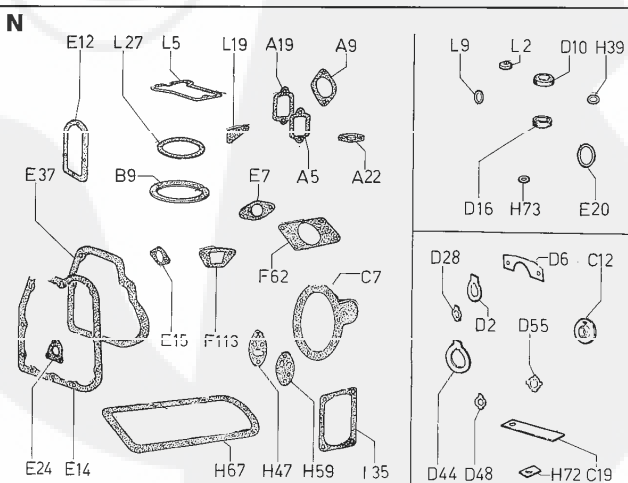
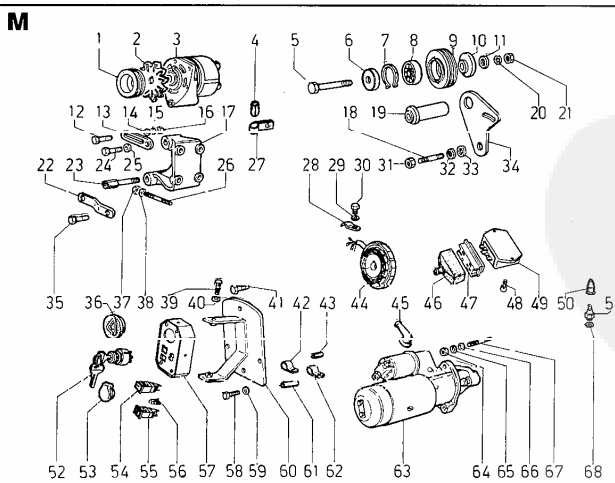
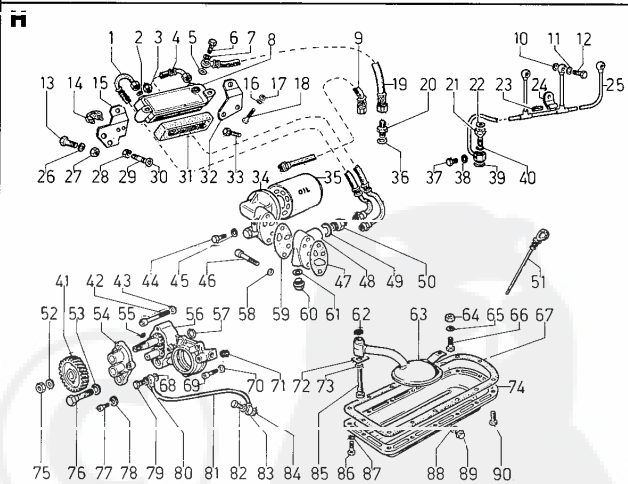
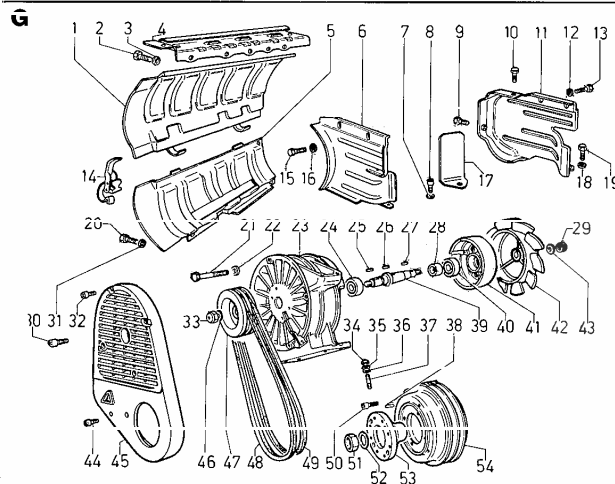
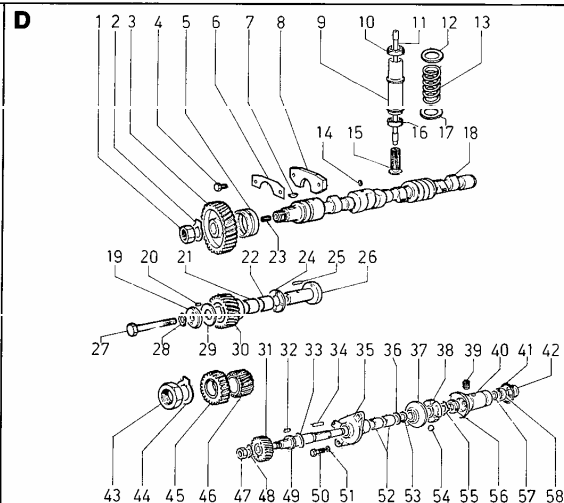
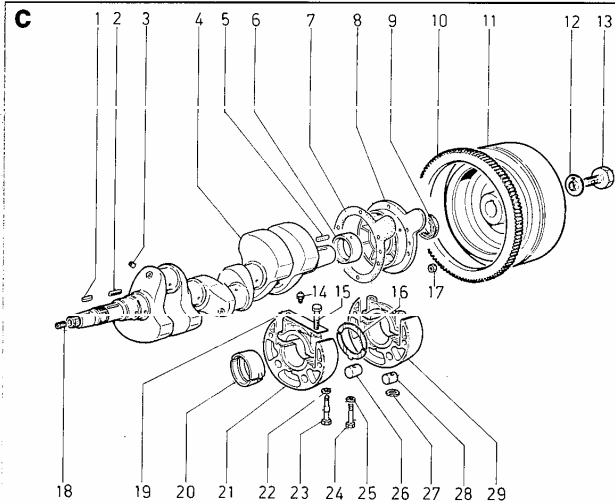

SERVICE

Per assistenza e ricambi rivolgersi a stazioni di servizio autorizzate Lombardini. N. tel. su libretto service e su pagine gialle.
 Pour toute exigence de service après-vente et pièces détachées, s'adresser aux Stations de service du réseau Lombardini. N. de téléphone indiqué sur brochure relative au service après-vente et annuaire catégorique.
 For spare parts and after-sale assistance contact authorized Lombardini service centers. Tel. No. appears on service booklet and telephone directory.
 Für Service und Ersatzteile bitten wir, sich an autorisierte Werkstätte zu wenden. Telef. Nummer laut unserem Service - Büchlein und Fernsprechbuch.
 Para asistencia y repuestos, dirigirse a las estaciones de servicio autorizadas Lombardini. N. Tel. su libretto service y su hojas amarillas.
 Para assistência e recâmbios dirigir-se às estações de serviço autorizadas Lombardini. Número telefone é sobre a caderneta de serviço e sobre as páginas amarelas.

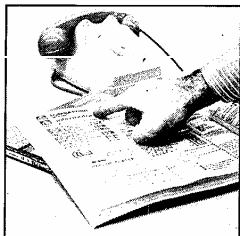
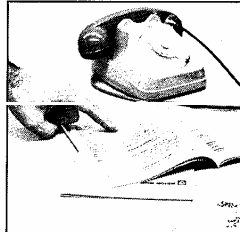
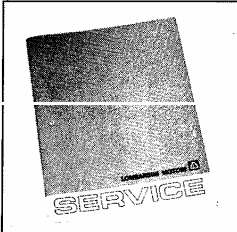

**ORDINI RICAMBI
 COMMANDES PIECES
 PART ORDERS
 E-TEIL BESTELLUNGEN
 PEDIDOS DE REPUESTOS
 PEDIDOS RECÂMBIOS**

**TIPO MOTORE
 TYPE DE MOTEUR
 ENGINE TYPE
 MOTORTYP
 TIPO DEL MOTOR
 TIPO DE MOTOR**

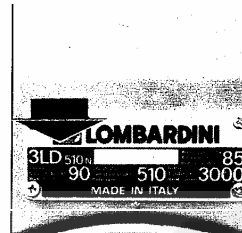
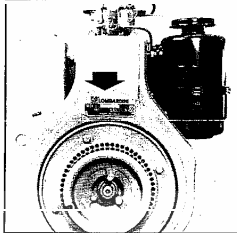

**MATRICOLA
 MATRICULE
 SERIAL NUMBER
 MOTORENNUMMER
 NUMERO DEL MOTOR
 NUMERO DO MOTOR**

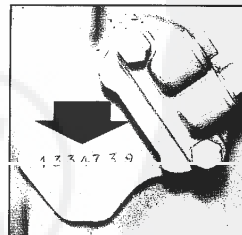
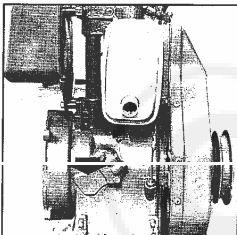
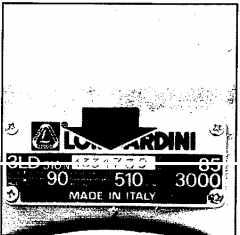
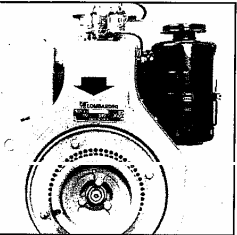

**TIPO DELLA MACCHINA
 TYPE DE MACHINE
 EQUIPMENT TYPE
 MASCHINENTYP
 MODELO DE LA MAQUINA
 TIPO DA MÁQUINA**

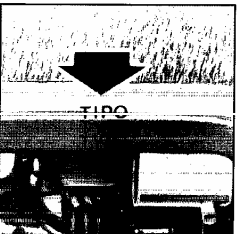
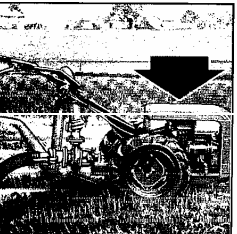

**MATRICOLA del ricambio
 REFERENCE de la pièce
 SPARE PART number
 BESTELNUMMER des
 Teiles
 REFERENCIA del repuesto
 REFERÈNCIA do recâmbio**

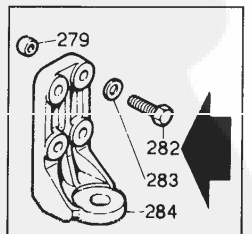
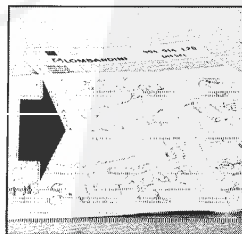

FABBRICA ITALIANA MOTORI S.p.A.
 42100 REGGIO EMILIA, ITALIA - CAS. POST. 106 - Tel. (0522) 3891 - Telegr.: LOMBARMOTOR - Telex: 530003 MOTLOM I

LOMBARDINI USA: 2150 Boggs Road Bldg. 300, Suite 300 - Duluth, GA 30136, USA
 LOMBARDINI FRANCE: Zone Industri. Nord, Arnas - Villefranche S/Saône, France
 LOMBARDINI MOTOREN GMBH: Berner Str. 54, 6000 Frankfurt/Main 56, Deutschland
 LOMBARDINI MOTORES: Zona Covà Solera - Rubí/Barcelona, España

Matricola 1.5302.421

Mod. 508B3
5-1992
Subject to alteration

Printed in Italy



LOMBARDINI

Gr. 5/3

TAVOLA RICAMBI SPARE PARTS TABLE TABLEAU PIECES DETACHEES. 1.5302.421

Maggio/May/Mai 1992

MOTORI/ENGINES/MOTEURS Gr. 5/3 cil./cyl.			
Colonna/Column/Colonne	1 =	5LD 824-3/B Versione/Version std.	726780
"	"	2 = 5LD 825-3	" 710503
"	"	3 = 5LD 930-3	" 718372

Vedi/See/Voir

Libretto Uso e Man./Use-Maint.booklet/Livret Emploi-Entret. 1.5302.152
 Libretto Service/Service directory/Reseau S.A.V. 1.7968.002
 Serie accessori/Accessory set/Jeu accessoires 2830.8140.081

note/remarks/remarques

- F - alta movimentazione/fast moving part/haut mouvement.
- S - media movimentazione/medium moving part/moyen mouvement.
- D - bassa movimentazione/slow moving part/bas mouvement.
- E - ad esaurimento/exhausting part/piece en epuisement.
- N - particolare nuovo o fornito su richiesta/
-new part or part supplied upon request/
-piece nouvelle ou fournie sur demande.
- A - valido dal motore.../from eng.S.No.../à partir du moteur... *
- B - valido fino al motore.../up to eng.S.No.../jusqu'au moteur... *
- I - intercambiabile/interchangeable.
* (vedi Circolare Tecnica/see Service Letter/voir Circ.Techn.)
- V - stock per Off.Service/stock for Service Dealer/stock pour Stations Service
- C - stock vitale per Costruttori, Esportatori, Enti di Stato.
vital stock for Producers, Exporters, State Companies.
stock vital pour Constructeurs, Export., Institut. de l'Etat.
- R - stock Rettif./Grinding Workshops stock/stock pour Usines de Rectification
10/50/2-q.ta minima fornibile/min.supplied q.ty/q.te min.fournie.
- = gruppo completo/assembly/groupe complet.
- + componente del gruppo/assembly component/composant du groupe.

Serie guarnizioni/Gasket set/Jeu de joints	5LD 675-3	672.8180.066
"	5LD 824-3 - 5LD 825-3	822.8180.068
"	5LD 930-3	933.8180.069
Serie anelli/O ring set/Jeu de bagues		672.8150.011
Serie lamierini/Lock set/Jeu de plaquettes		830.8190.011

Tipo mot./Eng.type/Type mot. Blocco motore/Short block/Bloc moteur

5LD 824-3 - 5LD 825-3	8230.1560.076
5LD 930-3	9330.1560.078

Descrizioni non impegnative/Subject to modifications/Modifications réservées
TECC/AMI/Assistenza Tecnica Lombardini/Maggio 1992

Riquadro/Drawing/Dessin A ASPIRAZIONE E SCARICO INTAKE AND EXHAUST ADMISSION ET ECHAPPEMENT	Riquadro/Drawing/Dessin G RAFFREDDAMENTO COOLING SYSTEM CIRCUIT DE REFROIDISSEMENT
Riquadro/Drawing/Dessin B CILINDRO, BIELLA E PISTONE CYLINDER, CONNECTING ROD AND PISTON SET CYLINDRE, BIELLE ET PISTON	Riquadro/Drawing/Dessin H CIRCUITO DI LUBRIFICAZIONE LUBRICATING SYSTEM CIRCUIT DE LUBRIFICATION
Riquadro/Drawing/Dessin C ALBERO A GOMITO, SUPPORTO E VOLANO CRANKSHAFT, FLYWH.SIDE SUPPORT AND FLYWHEEL VILEBREQUIN, PALIER ET VOLANT	Riquadro/Drawing/Dessin I COMANDI CONTROLS COMMANDES
Riquadro/Drawing/Dessin D DISTRIBUZIONE E REGOLATORE DI GIRI TIMING AND SPEED GOVERNOR DISTRIBUTION ET REGULATEUR DE VITESSE	Riquadro/Drawing/Dessin L TESTA, CAPPELLO BILANCIERI E VALVOLE CYLINDER HEAD, ROCKER ARM BOX AND VALVES CULASSE, COUV. COURTEURS ET SOUPAPES
Riquadro/Drawing/Dessin E BASAMENTO, PORTINA LATO DISTRIBUZIONE E PIEDI CRANKCASE COVER GEAR AND MOUNTS CARTER MOTEUR, CARTER COTE DISTRIB., PIEDS	Riquadro/Drawing/Dessin M AVVIAMENTO STARTING DEMARREUR
Riquadro/Drawing/Dessin F CIRCUITO COMBUSTIBILE FUEL SYSTEM CIRCUIT CARBURANT	Riquadro/Drawing/Dessin N COMPOSIZIONE SERIE GUARNIZIONI/ANELLI GASKET/O RING SET COMPOSITION COMPOSITION SERIE JOINTS/BAGUES



Pos.	Matricola/Part No.	Note/Remarks	Q.ty/Eng.
A 1+	2135.093 276 F C	cappello/air inlet cover	1 1 1 1
A 2	=3700.346 832 SVIC	FILTRO ARIA/AIR CLEANER (Pos. 1-2-14-15-16-43-51)	1 1 1 1
A 3	8636.028 824 SV C	supporto antivibr./vibration isolator	1 1 1 1
A 4	2486.041 823 S C	collettore aspirazione/inlet manifold	1 1 1 1
A 5	4420.007 276 FV C 10	guarnizione/gasket	3 3 3 3
A 6	2486.013 2770 S	collettore scar./exh.manifold	1 1 1 1
A 7	-	-
A 8	3240.095 9 FV C 10	dado/nut	6 6 6 6
A 9	4500.079 276 FV C 10	guarnizione/gasket	1 1 1 1
A 10	2940.087 2760 F C	curva scarico/exhaust elbow	1 1 1 1
A 11	6780.008 9 FV C 10	prigioniero/stud M 8 X 20 (32)	2 2 2 2
A 12	-	-
A 13	3240.095 9 FV C 10	dado/nut	2 2 2 2
A 14+	4776.029 276 S C 10	guarnizione/gasket	1 1 1 1
A 15+	5496.074 276 FV C	massa filtrante/filtering element	1 1 1 1
A 16+	1261.056 9 FV C 10	anello tenuta/seal ring	1 1 1 1
A 17	7555.007 9 DV C 10	rondella/washer	8 8 8 8
A 18	3240.018 9 FV 10	dado/nut	8 8 8 8
A 19	4420.008 276 FV C 10	guarnizione/gasket	3 3 3 3
A 20	7565.007 9 FV C 10	rondella/washer	6 6 6 6
A 21	3240.018 9 FV 10	dado/nut	6 6 6 6
A 22	4500.079 276 FV C 10	guarnizione/gasket	1 1 1 2
A 23	4500.079 276 FV C 10	guarnizione/gasket	1 1 1 1
A 24	3240.095 9 FV C 10	dado/nut	2 2 2 2
A 25	1770.006 9 S 10	bullone/bolt M 8 X 1,25 X 25	2 2 2 2
A 26	2485.072 2770 D	collettore scarico/exhaust manifold	1 1 1 1
A 27	6780.008 9 FV C 10	prigioniero/stud M 8 X 20 (32)	2 2 2 4
A 28	4500.079 276 FV C 10	guarnizione/gasket	1 1 1 1
A 29	3240.095 9 FV C 10	dado/nut	2 2 2 4
A 30	-	-
A 31	5300.010 277 S C	piastra/plate	1 1 1 2
A 32	5461.047 2830 F C	marmitta/muffler	1 1 1 1
A 33	-	-
A 34	6780.008 9 FV C 10	prigioniero/stud M 8 X 20 (329)	2 2 2 2
A 35	3240.095 9 FV C 10	dado/nut	2 2 2 2
A 36	7565.013 9 F C 10	rondella/washer	1 1 1 1
A 37	5460.219 2760 N	marmitta/muffler	1 1 1 1
A 38	7625.055 9 SV C 10	rondella/washer	1 1 1 1
A 39	8546.014 2760 F C	staffa/brace	1 1 1 1
A 40	3240.033 9 FV 10	dado/nut	1 1 1 1
A 41	9170.028 2910 F C	terminale/muffler-end	1 1 1 1
A 42	9400.056 822 S C	tubo depressione/suction line	1 1 1 1
A 43+	4115.048 276 F C 10	gancio/hook	2 2 2 2
A 44	-	-
A 45	7626.018 9 N 10	rondella/washer	1 1 1 1
A 46	8545.121 9330 N	staffa/muffler brace	1 1 1 1
A 47	9170.046 2760 N	terminale/muffler end	1 1 1 1
A 48	3617.081 2760 N	fascetta/clamp	1 1 1 1
A 49	1780.031 9 FV 10	bullone/bolt M 10 X 1,5 X 25	1 1 1 1
A 50	7565.011 9 F C 10	rondella/washer	1 1 1 1
A 51+	5496.180 276 SVAC	massa poliuret./polyureth.element	1 1 1 1
B 1+	1630.006 270 FV CR	bronz.piede biella/small end bearing	3 3 3 3
"	1630.011 832 FV CR	"	3 3 3 3
B 2	=6500.153 672 FV C	PISTONE COMPLETO/PISTON SET std.	3 3 3 3
"	=6500.156 672 F CR	" " +0,50	3 3 3 3
"	=6500.157 672 F CR	" " +1,00	3 3 3 3
"	=6500.664 822 FVAC	" " std.	3 3 3 3
"	=6500.665 822 F ACR	" " +0,50	3 3 3 3
"	=6500.698 822 F ACR	" " +1,00	3 3 3 3
"	=6500.159 933 FV C	" " std.	3 3 3 3
"	=6500.160 933 F CR	" " +0,50	3 3 3 3
"	=6500.161 933 F CR	" " +1,00	3 3 3 3
		(Pos. 2-3-4-5)	
Motore/Engine	5LD 675-3	Versione/Version	710212
"	5LD 824-3/B	"	726780
"	5LD 825-3	"	710503
"	5LD 930-3	"	718372



Pos.	Matricola/Part No.	Note/Remarks	Q.ty/Eng.
B 3+	8210.052 276 FV C	serie segmenti/ring set std.	3
"	8211.053 276 F CR	" " +0,50	3
"	8211.054 276 F CR	" " +1,00	3
"	8211.212 822 FVAC	" " std.	3 3
"	8211.139 822 F ACR	" " +0,50	3 3
"	8211.140 822 F ACR	" " +1,00	3 3
"	8211.014 933 FV C	" " std.	3
"	8211.015 933 F CR	" " +0,50	3
"	8211.016 933 F CR	" " +1,00	3
B 4+	8480.021 279 S C	spinotto/gudgeon pin	3
"	8480.027 832 S C	" " "	3 3 3
R 5+	1240.026 9 FV C 10	anello seeger/snap ring	6
"	1240.031 9 FV C 10	" " "	6 6 6
B 6	1640.045 291 FV C	bronz.biella/large end bushing std.	3 3 3 3
"	1640.048 291 F CR	" " -0,25	3 3 3 3
"	1640.049 291 F CR	" " -0,50	3 3 3 3
B 7	=1526.004 276 F C	BIELLA COMPLETA/CONNECTING ROD	3
"	=1525.096 832 F C	" " "	3 3 3
		(Pos. 1-7-10-11)	
B 8	2380.101 672 FV C	cilindro/cylinder diam. 95	3
"	2380.095 932 FV C	" " diam.100	3 3
"	2380.134 933 FV C	" " diam.106	3
B 9	4410.055 822 FV C 10	guarnizione cilindro/cyl.gasket 0,50	3 3 3 3
"	4410.054 933 FV C 10	" " 0,50	3 3 3 3
B 10+	3203.034 9 FVIC 10	dado/nut	6 6 6 6
B 11+	1860.007 270 FV C 10	bullone/bolt	6 6 6 6
C 1+	2280.056 9 FV C 10	chiavetta/key	1 1 1 1
C 2+	2280.056 9 FV C 10	chiavetta/key	1 1 1 1
C 3+	2000.020 276 F C 10	tappo/expansion plug	6 6 6 6
C 4	=1050.189 673 S C	ALBERO A GOMITO/CRANKSHAFT	1
"	=1050.186 823 S C	" " "	1 1 1
		(Pos. 1-2-3-4-5-18)	
C 5+	2280.056 9 FV C 10	chiavetta/key	1 1 1 1
C 6	1611.078 822 FV C	br.l.volano/flywheel side bear. std.	1 1 1 1
"	1611.062 822 F CR	" " -0,25	1 1 1 1
"	1611.063 822 F CR	" " -0,50	1 1 1 1
"	1611.064 822 F CR	barenabile/bearing reamed	1 1 1 1
C 7	4701.013 276 S C 50	guarnizione/gasket	1 1 1 1
C 8	=8676.095 822 S C	SUPPORTO L.VOL./FLYWHEEL SIDE SUPPORT	1
"	=8676.094 824 S C	" " "	1 1 1
		(Pos. 8-9-14)	
C 9+	1213.135 9 FV C	anello tenuta/seal ring	1 1 1 1
C 10+	2816.010 276 F C	corona avviamento/crown gear	1 1 1 1
C 11	=9881.054 276 S C	VOLANO con CORONA/FLYWHEEL with CROWN	1 1 1 1
		(Pos. 10-11)	
C 12	5111.005 276 F C 10	lamierino/tabwasher	1 1 1 1
C 13	1861.045 276 S C	bullone/bolt	1 1 1 1
C 14+	8980.025 277 FV C 10	tappo/plug	3
"	8485.001 823 DV C	spruzzatore/sprayer	3 3 3
C 15+	1780.029 9 D C 10	bullone/bolt M 10 X 1,5 X 75	4 4 4 4
C 16	1257.012 832 FV C	anello reggispinta/thrust washer	2 2 2 2
C 17	3203.047 9 FV C 10	dado/nut	6 6 6 6
C 18+	9765.108 9 N 10	vite/screw	1 1 1 1
C 19+	5111.074 822 DV C 10	lamierino/safety plate	2 2 2 2
C 20	1611.061 822 FV C	br.supp.cent./middle supp.bear. std.	2 2 2 2
"	1611.073 822 F CR	" " -0,25	2 2 2 2
"	1611.074 822 F CR	" " -0,50	2 2 2 2
"	1611.075 822 F CR	barenabile/bearing reamed	2 2 2 2
C 21	=8660.037 672 S C	SUPPORTO CENTRALE/MIDDLE SUPPORT	1
"	=8660.039 823 S C	" " "	1 1 1
		(Pos. 14-15-19-21-22-23-24-25-26-27-28)	
C 22+	7625.020 9 D C 10	rondella/washer	2 2 2 2
C 23+	1861.042 276 F C 10	bullone/bolt	2 2 2 2
Motor/Engine		5LD 675-3	Versione/Version 710212
"		5LD 824-3/B	" " 726780
"		5LD 825-3	" " 710503
"		5LD 930-3	" " 718372



Pos.	Matricola/Part No.	Note/Remarks	Q.ty/Eng.
C 24+	1790.051 9 D C 10	bullone/bolt M 12 X 1,75 X 95	2 2 2 2
C 25+	7625.026 9 S 10	rondella/washer	2 2 2 2
C 26+	5957.003 822 SV C 10	nottolino/lockpin	2 2 2 2
C 27+	7565.013 9 S C 10	rondella/washer	2 2 2 2
C 28+	5957.011 822 DV C 10	nottolino/lockpin	2 2 2 2
C 29	=8660.038 673 S C	SUPPORTO/FLYWHEEL SIDE MIDDLE SUPPORT	1
"	=8660.040 823 S C	" " " "	1 1 1
		(Pos. 14-15-19-22-23-24-25-26-27-28-29)	
D 1	3260.059 9 SV C 10	dado/nut	1 1 1 1
D 2	5111.025 276 D C 10	lamierino/tabwasher	1 1 1 1
D 3	4910.019 276 S	ingranaggio/timing gearwheel	1 1 1 1
D 4	1770.005 9 F 10	bullone/bolt M 8 X 1,25 X 22	2 2 2 2
D 5+	1600.055 276 FV C	bronz.alb.camme/camshaft bearing std.	1 1 1 1
"	1600.056 276 F CR	" " -0,25	1 1 1 1
"	1600.057 276 F CR	" " -0,50	1 1 1 1
"	1600.058 276 F CR	" " -1,00	1 1 1 1
"	1600.059 276 F CR	+1,00 su diam.esterno/on ext.diameter	1 1 1 1
D 6	5111.007 276 S C 10	lamierino/safety plate	1 1 1 1
D 7	2280.056 9 FV C 10	chiavetta/key	1 1 1 1
D 8	6275.057 276 S C	piastra/plate	1 1 1 1
D 9	9520.049 672 FVAC	tubo protezione/guard tube	6
"	9520.050 822 FVAC	" "	6 6 6 6
D 10	1261.069 672 FVAC 10	anello tenuta/seal ring	6 6 6 6
D 11	1410.028 276 FV C	asta punteria/pushrod	6
"	1410.029 832 FV C	" "	6 6 6 6
D 12	7625.100 672 S AC 10	rondella/washer	6 6 6 6
D 13	5801.135 672 SVAC 10	molla/spring	6 6 6 6
D 14	9765.053 9 D C 10	vite/screw M 5 X 0,8 X 10	1 1 1 1
D 15	7215.020 276 FV C	punteria/tappet	2 2 2 2
D 16	1261.069 672 FVAC 10	anello tenuta/seal ring	6 6 6 6
D 17	7625.100 672 S AC 10	rondella/washer	6 6 6 6
D 18	1011.070 823 S C	albero camme/camshaft	1 1 1 1
D 19	7670.084 276 N	rondella/washer	1 1 1 1
D 20	8430.036 9 D C 10	spina/locking needle	1 1 1 1
D 21+	1685.024 276 SV C	bronzina/bearing	1 1 1 1
D 22+	1685.024 276 SV C	bronzina/bearing	1 1 1 1
D 23	9765.018 9 D C 10	vite/screw M 10 X 1,5 X 16	1 1 1 1
D 24	1300.067 276 DV C 10	anello reggispinta/thrust washer	1 1 1 1
D 25	4320.021 276 S 10	grano/dowel	1 1 1 1
D 26	6130.025 276 D C	perno/gear shaft	1 1 1 1
D 27	1861.044 9 D C 10	bullone/bolt	1 1 1 1
D 28	5111.003 276 S C 10	lamierino/tabwasher	1 1 1 1
D 29	3495.040 276 S C 10	distanziale/spacer	1 1 1 1
D 30	=4935.048 276 F C	INGRANAGGIO/INTERMEDIATE GEARWHEEL (Pos. 21-22-30)	1 1 1 1
D 31	4935.037 276 S	ingranaggio/speed governor gearwheel	1 1 1 1
D 32	2200.011 9 D C 10	chiavetta/key	1 1 1 1
D 33+	1300.073 276 D C 10	anello reggispinta/thrust washer	1 1 1 1
D 34+	2200.010 9 D 10	chiavetta/key	1 1 1 1
D 35	=7362.120 823 S C	REGOLATORE DI GIRI/SPEED GOVERNOR (Pos. 33-34-35-36-37-38-39-40-41-42-49-52-53-54-55-56-57-58)	1 1 1 1
D 35	=8590.018 276 D C	SUPPORTO PERNO/GOVERN.LHAFT SUPPORT (Pos. 35-52)	1 1 1 1
D 36+	1300.074 276 D C 10	anello reggispinta/thrust washer	1 1 1 1
D 37+	2085.041 276 D	campana/governor bell	1 1 1 1
D 38+	2471.045 823 D C	collare/collar	1 1 1 1
D 39+	9765.009 9 N 10	vite/screw M 8 X 1,25 X 10	1 1 1 1
D 40+	2086.029 276 D	campana/governor bell	1 1 1 1
D 41+	1160.015 276 D C 10	anello/circlip	1 1 1 1
D 42+	6000.042 276 D C 10	pastiglia/drive rod	1 1 1 1
D 43	3206.018 276 SV C	dado/nut	1 1 1 1
D 44	5111.004 276 D C 10	lamierino/tabwasher	1 1 1 1
D 45	4936.081 823 N A	ingranaggio/gearwheel	1 1 1 1
D 46	4936.080 823 N A	ingranaggio/gearwheel	1 1 1 1
D 47	3260.004 9 DV C 10	dado/nut	1 1 1 1
D 48	5111.027 276 D C 10	lamierino/tabwasher	1 1 1 1
Motore/Engine	5LD 675-3	Versione/Version	710212
"	5LD 824-3/B	"	726780
"	5LD 825-3	"	710503
"	5LD 930-3	"	718372



Pos.	Matricola/Part No.	Note/Remarks	Q.ty/Eng.			
D 49+	1085.004 276 D C	albero/speed governor shaft	1	1	1	1
D 50	1770.004 9 F C 10	bullone/boit M 8 X 1,25 X 20	2	2	2	2
D 51	7565.007 9 F C 10	rondella/washer	2	2	2	2
D 52+	1702.008 276 SV C 10	bronzina/bearing	2	2	2	2
D 53+	1240.018 9 D 10	anello seeger/snap ring	1	1	1	1
D 54+	8245.017 9 S 10	sfera/ball	8	8	8	8
D 55+	5111.022 276 D C 10	lamierino/tabwasher	1	1	1	1
D 56+	4130.063 276 SV C 10	ghiera/ring nut	1	1	1	1
D 57+	1240.007 9 FV C 10	anello seeger/snap ring	1	1	1	1
D 58+	3100.032 9 S C	cuscinetto/ball bearing	1	1	1	1
E 1+	8965.021 9 S C 10	tappo/plug	1	1	1	1
E 2+	4670.058 9 FV C 10	guarnizione/copper gasket	1	1	1	1
E 3+	8965.023 9 D C 10	tappo/plug	1	1	1	1
E 4+	4670.058 9 FV C 10	guarnizione/copper gasket	1	1	1	1
E 5	6850.065 276 S C	prigioniero/head stud	12			
"	6850.082 832 S C	" "		12	12	12
E 6+	9765.009 9 N 10	vite/screw M 8 X 1,25 X 10	1	1	1	1
E 7	4775.080 276 N 50	guarnizione/gasket	1	1	1	1
E 8	7301.036 822 S C 10	raccordo/connection	1	1	1	1
E 9	6902.036 823 SV C	prolunga/extension	1	1	1	1
E 10+	4775.250 822 DV C 10	guarnizione/gasket	1	1	1	1
E 11	=9032.027 822 FV C	TAPPO RIF.OLIO/FILLER OIL CAP (Pos. 10-11)	1	1	1	1
E 12	4601.046 276 S 10	guarnizione/gasket	1	1	1	1
E 13	=2690.332 822 S C	COPERCHIO DISTR./TIMING HOUSING COVER (Pos. 13-23)	1	1	1	1
E 14	4431.000 276 SV C 10	guarnizione/gasket	1	1	1	1
E 15+	4560.017 822 DV C 10	guarnizione/gasket	1	1	1	1
E 16	6800.055 9 D C 10	prigioniero/stud M 10 X 25 (37)	2	2	2	2
E 17	7565.011 9 F C 10	rondella/washer	2	2	2	2
E 18	7555.008 9 FV C 10	rondella/washer	2	2	2	2
E 19	3240.033 9 FV 10	dado/nut	2	2	2	2
E 20+	1200.036 9 FV C 10	anello OR/rubber oil seal	1	1	1	1
E 21+	2710.039 276 S C 10	coperchio/cover	1	1	1	1
E 22	9732.074 9 S C 10	vite/screw M 8 X 1,25 X 20	2	2	2	2
E 23+	1210.087 9 FV C 10	anello tenuta/seal ring	1	1	1	1
E 24	4431.013 276 D 10	guarnizione/gasket	1	1	1	1
E 25	2615.037 822 D C	coperchio/cover	1	1	1	1
E 26+	1611.079 822 FV C	bronz.l.distr./gear side bearing std.	1	1	1	1
"	1611.070 822 F CR	" " -0,25	1	1	1	1
"	1611.071 822 F CR	" " -0,50	1	1	1	1
"	1611.072 822 F CR	barenabile/bearing reamed	1	1	1	1
E 27+	6780.015 9 SV C 10	prigioniero/stud M 8 X 21 (40)	6	6	6	6
E 28	7555.007 9 DV C 10	rondella/washer	2	2	2	2
E 29	2615.018 276 S C	coperchio/cover	1	1	1	1
E 30	9730.009 9 D 10	vite/screw M 6 X 1 X 12	3	3	3	3
E 31	7555.004 9 FV C 10	rondella/washer	3	3	3	3
E 32	9732.092 9 F C 10	vite/screw M 8 X 1,25 X 18	12	12	12	12
E 33+	8460.055 276 D C 10	spina/caper pin	2	2	2	2
E 34	=7885.022 822 D C	SCATOLA DISTR./GEAR TIMING HOUSING (Pos. 33-34-G 37)	1	1	1	1
E 35	1770.006 9 S 10	bullone/bolt M 8 X 1,25 X 25	9	9	9	9
E 36	7555.007 9 DV C 10	rondella/washer	12	12	12	12
F 37	4680.037 276 N 50	guarnizione/gasket	1	1	1	1
E 38	1770.010 9 N 10	bullone/bolt M 8 X 1,25 X 35	2	2	2	2
E 39	1970.073 276 D C 10	bussola/sleeve	2	2	2	2
E 40	=1510.176 823 D C	BASAMENTO/CRANKCASE	1	1	1	1
"	=1510.179 933 S C	" "				
		(Pos. 1-2-3-4-6-20-21-26-27-40-41- D 5-F115-H 20-H 36-M 67)				
E 41+	9765.104 9 D C 10	vite/screw M 14 X 1,5 X 10	2	2	2	2
E 42	1970.084 276 N 10	bussola/sleeve	2	2	2	2
E 43	6428.028 276 D C	piede/engine mount	4			
"	6428.039 832 S C	" "		4	4	4
E 44	7565.013 9 S C 10	rondella/washer	11	11	11	11
"	7626.018 9 N 10	rondella/washer	1	1	1	1
Motore/Engine 5LD 675-3			Versione/Version 710212			
" " 5LD 824-3/B			" " 726780			
" " 5LD 825-3			" " 710503			
" " 5LD 930-3			" " 718372			



Pos.	Matricola/Part No.	Note/Remarks	Q.ty/Eng.			
E 45	1790.026 9 D C 10	bullone/bolt M 12 X 1,25 X 35	12	12	12	12
F 1	9571.015 277 FV C	tubo spurgo/bleeding pipe	1	1	1	1
F 2	1901.029 9 FV C 10	bullone raccordo/connection bolt	3	3	3	3
F 3	4670.058 9 FV C 10	guarnizione/copper gasket	3	3	3	3
F 4	4670.058 9 FV C 10	guarnizione/copper gasket	3	3	3	3
F 5	7301.006 500 D	raccordo/connection	3	3	3	3
F 6	4130.053 260 SV C	ghiera/ring nut	3	3	3	3
F 7	1570.016 260 DV C	bocchettone/filler	3	3	3	3
F 8	4370.007 260 DV C 10	guarnizione/gasket	3	3	3	3
F 9					
F 10	5800.038 260 SV C	molla/spring	3	3	3	3
F 11	1420.012 260 DV C	asta comando/control rod	3	3	3	3
F 12	3616.018 276 S C 10	fascetta/strip fixing	2	2	2	2
F 13	7555.004 9 FV C 10	rondella/washer	3	3	3	3
F 14	9730.003 9 D 10	vite/screw M 5 X 0,8 X 10	2	2	2	2
F 15	3240.020 9 SV C 10	dado/nut	2	2	2	2
F 16	3240.018 9 FV 10	dado/nut	2	2	2	2
F 17	7565.007 9 F C 10	rondella/washer	2	2	2	2
F 18	7625.012 9 FV C 10	rondella/washer	2	2	2	2
F 19	8635.059 9 FV C	supporto antivib./vibration isolator	2	2	2	2
F 20+	9043.015 276 FV C	tappo serbatoio/fuel tank cap	1	1	1	1
F 21	7565.007 9 F C 10	rondella/washer	2	2	2	2
F 22	3240.018 9 FV 10	dado/nut	2	2	2	2
F 23	3240.020 9 SV C 10	dado/nut	2	2	2	2
F 24	=8101.032 276 S C	SERBATOIO COMB./FUEL TANK (Pos. 20-24)	1	1	1	1
F 25	4650.037 260 DV C 10	guarnizione/gasket	3	3	3	3
F 26	4130.062 276 SV C	ghiera/ring nut	3	3	3	3
T 27	5400.046 276 F C 10	manicotto/rubber sheathing	1	1	1	1
F 28	5400.046 276 F C 10	manicotto/rubber sheathing	2	2	2	2
F 29	3616.018 276 S C 10	fascetta/strip fixing	1	1	1	1
F 30	9372.018 277 FV C	tubo mandata/delivery pipe	1	1	1	1
"	9375.687 930 SVIC	"	1	1	1	1
F 31	9372.007 276 FV C	tubo mandata/delivery pipe	1	1	1	1
"	9375.689 930 FVIC	"	1	1	1	1
F 32	9372.006 276 FV C	tubo mandata/delivery pipe	1	1	1	1
"	9375.688 930 FVIC	"	1	1	1	1
F 33	6615.011 276 F C	portapolverizzatore/nozzle holder	3	3	3	3
F 34+	6780.057 9 FV C 10	prigioniero/stud M 8 X 30 (45)	6	6	6	6
T 35	7565.007 9 F C 10	rondella/washer	6	6	6	6
F 36	3240.018 9 FV 10	dado/nut	6	6	6	6
F 37	4670.009 9 FV C 10	guarnizione/copper gasket 0,50	3	3	3	3
"	4670.010 9 FV C 10	" " 1,00	3	3	3	3
"	4670.011 9 FV C 10	" " 1,50	3	3	3	3
F 38	6531.010 276 FV C	polverizzatore/nozzle	3	3	3	3
F 39	3206.045 276 SV C 10	dado/nut	2	2	2	2
F 40	8545.031 276 D C	staffa/brace	2	2	2	2
F 41	7565.013 9 S C 10	rondella/washer	2	2	2	2
F 42	1790.027 9 D C 10	bullone/bolt M 12 X 1,25 X 20	2	2	2	2
F 43	8865.091 2760 D C	supporto serbatoio/tank support	1	1	1	1
F 44	3240.020 9 SV C 10	dado/nut	2	2	2	2
F 45	4670.059 9 FV C 10	guarnizione/copper gasket	1	1	1	1
F 46	9372.003 276 SV C 10	tubo combustibile/fuel pipe	1	1	1	1
F 47	4670.060 9 FV C 10	guarnizione/copper gasket	1	1	1	1
F 48	1901.031 9 FV C 10	bullone raccordo/connection bolt	1	1	1	1
F 49	4775.196 9 SV C 10	guarnizione/gasket	1	1	1	1
F 50	9080.037 9 FV C 10	tappo/deaeration plug	1	1	1	1
F 51	9732.074 9 S C 10	vite/screw M 8 X 1,25 X 20	4	4	4	4
F 52	7625.010 9 FV C 10	rondella/washer	4	4	4	4
F 53	8865.090 2760 D C	supporto/tank support	1	1	1	1
"	8866.002 8320 D C	"	1	1	1	1
F 54	1780.003 9 D 10	bullone/bolt M 10 X 1,5 X 18	2	2	2	2
F 55	7625.012 9 FV C 10	rondella/washer	2	2	2	2
F 56	7565.007 9 F C 10	rondella/washer	2	2	2	2
F 57	1901.045 9 FV C 10	bullone raccordo/connection bolt	1	1	1	1
F 58	4670.059 9 FV C 10	guarnizione/copper gasket	1	1	1	1
F 59	1901.032 9 FV C 10	bullone raccordo/connection bolt	1	1	1	1
F 60	4670.061 9 FV C 10	guarnizione/copper gasket	1	1	1	1
F 61	4670.061 9 FV C 10	guarnizione/copper gasket	1	1	1	1
F 62	4580.020 277 D C 50	guarnizione/gasket 0,10	4	4	4	4
"	4580.021 277 N 50	" " 0,50	2	2	2	2
"	4580.069 673 N 50	" " 0,05	1	1	1	1
Motore/Engine 5LD 675-3		Versione/Version 710212				
" " 5LD 824-3/B		" " 726780				
" " 5LD 825-3		" " 710503				
" " 5LD 930-3		" " 718372				



Pos.	Matricola/Part No.	Note/Remarks	Q.ty/Eng.
F 63	6590.051 823 F C	pompa iniezione/injection pump	1 1 1
"	6590.058 933 F C	"	1 1 1
F 64	4670.060 9 FV C 10	guarnizione/copper gasket	1 1 1
F 65	9080.035 277 SV C 10	tappo/cap	1 1 1
F 66	5755.034 271 SV C 10	molla/spring	3 3 3
F 67	8335.029 271 SV C 10	spessore/shim	3 3 3
F 68	7265.008 271 FV C 10	raccordo/connection	3 3 3
F 69	1200.031 9 FV C 10	anello OR/rubber oil seal	3 3 3
F 70	7565.011 9 F C 10	rondella/washer	2 2 2
F 71	6487.004 276 S C 10	piolo/pivot	2 2 2
F 72	7980.042 276 S C 10	scodellino/cup	2 2 2
F 73	8440.012 276 FV C 10	tampone/buffer	2 2 2
F 74	4670.059 9 FV C 10	guarnizione/copper gasket	1 1 1
F 75	4670.059 9 FV C 10	guarnizione/copper gasket	1 1 1
F 76	1901.030 9 FV C 10	bullone raccordo/connection bolt	1 1 1
F 77	7555.008 9 FV C 10	rondella/washer	2 2 2
F 78	1780.005 9 FV 10	bullone/bolt M 10 X 1,5 X 28	2 2 2
F 79	4670.061 9 FV C 10	guarnizione/copper gasket	1 1 1
F 80	9375.183 823 S	tubo combustibile/fuel pipe	1 1 1
F 81	1580.023 276 F C 10	boccola/bushing	1 1 1
F 82	4650.052 277 DV C 10	guarnizione/gasket	1 1 1
F 83	9672.012 500 F C	valvola mandata/delivery valve	3 3 3
F 84	7470.003 271 FV C 10	riempitore/filler	3 3 3
F 85	1901.030 9 FV C 10	bullone raccordo/connection bolt	1 1 1
F 86	4670.059 9 FV C 10	guarnizione/copper gasket	1 1 1
F 87	4670.059 9 FV C 10	guarnizione/copper gasket	1 1 1
F 88	6230.075 277 SV C 10	perno/pin	2 2 2
F 89	4850.009 260 FV C	guida/guide	2 2 2
F 90	4760.015 271 FV C 10	guarnizione/gasket	3 3 3
F 91	6578.026 673 FV C	pompante/injection plunger	3 3 3
"	6578.028 933 FV C	"	3 3 3
F 92	6230.068 260 SV C	perno/pin	3 3 3
F 93	7626.017 9 N	rondella/washer	1 1 1
F 94	2000.000 2 F C 10	copiglia/cotter pin	1 1 1
F 95	7980.020 260 SV C	scodellino/cup	3 3 3
F 96		
F 97	8400.048 9 D 10	spina/taper pin	1 1 1
F 98	=3730.038 823 SV C	FILTRO COMBUST./FUEL FILTER (Pos. 98-99)	1 1 1
F 99+	2175.046 276 FV C	cartuccia comb./fuel filter element	1 1 1
F100	9375.153 823 SV C	tubo combustibile/fuel pipe	1 1 1
F101	4670.061 9 FV C 10	guarnizione/copper gasket	1 1 1
F102	1901.032 9 FV C 10	bullone raccordo/connection bolt	1 1 1
F103	1970.054 260 DV C	bussola/sleeve	3 3 3
F104	7770.020 260 SV C	rullo/roller	3 3 3
F105	7215.017 260 FV C	punteria/tappet	3 3 3
F106	6400.024 260 D	piattello/retainer	3 3 3
F107	5625.002 260 SV C	molla/spring	3 3 3
F108		
F109	1415.009 277 DV C	asta comando/control rod	1 1 1
F110	6230.069 260 DV C	perno/pin	3 3 3
F111		
F112	7200.042 276 SV C 10	puntalino/drive rod	1 1 1
F113	4580.041 560 FV C 10	guarnizione/gasket 1,00	1 1 1
"	4580.049 560 FV C 10	" " 0,50	1 1 1
"	4580.050 560 FV C 10	" " 0,80	1 1 1
F114	6585.030 276 FV C	pompa alimentazione/feed pump	1 1 1
F115+	6780.007 9 S 10	prigioniero/stud M 8 X 20 (32)	2 2 2
F116	3203.047 9 FV C 10	dado/nut	2 2 2
G 1	5066.052 673 D C	lamiera intermedia/middle panel	1 1 1
"	5066.043 823 D C	"	1 1 1
G 2	1760.001 9 FV 10	bullone/bolt M 6 X 1 X 10	1 1 1
G 3	7625.059 9 D C 10	rondella/washer	7 7 7
G 4	5066.049 823 D C	lamiera/panel	1 1 1
G 5	5066.162 821 N	lamiera/panel	1 1 1
"	5066.164 823 N A	"	1 1 1
G 6	5066.041 823 D C	lamiera/airtight plate	1 1 1
G 7	7565.007 9 F C 10	rondella/washer	2 2 2
G 8	9731.092 9 S 10	vite/screw M 8 X 1,25 X 14	2 2 2
G 9	1760.001 9 FV 10	bullone/bolt M 6 X 1 X 10	1 1 1
G 10	1760.001 9 FV 10	bullone/bolt M 6 X 1 X 10	1 1 1
G 11	5066.042 823 D C	lamiera/airtight plate	1 1 1
Motore/Engine	5LD 675-3	Versione/Version 710212	
"	5LD 824-3/B	" " 726780	
"	5LD 825-3	" " 710503	
"	5LD 930-3	" " 718372	



Pos.	Matricola/Part No.	Note/Remarks	Q.ty/Eng.				
G 12	7625.061	9 D C 10	rondella/washer	2	2	2	2
G 13	1760.003	9 F 10	bullone/bolt M 6 X 1 X 12	2	2	2	2
G 14	4115.051	823 D C 10	gancio/hook	2	2	2	2
G 15	1760.003	9 F 10	bullone/bolt M 6 X 1 X 12	2	2	2	2
G 16	7625.061	9 D C 10	rondella/washer	2	2	2	2
G 17	3350.021	276 D	deflettore/deflector	2			
"	3350.031	832 S C	"		2	2	2
G 18	7565.007	9 F C 10	rondella/washer	2	2	2	2
G 19	1770.002	9 FV 10	bullone/bolt M 8 X 1,25 X 16	2	2	2	2
G 20	1770.001	9 FV 10	bullone/bolt M 8 X 1,25 X 12	2	2	2	2
G 21	1760.068	9 S C 10	bullone/bolt M 6 X 1 X 90	4	4	4	4
C 22	7565.004	9 F C 10	rondella/washer	4	4	4	4
G 23	8565.034	823 S C	statore/stator	1	1	1	1
G 24	3003.052	9 SV C	cuscinetto/ball bearing	1	1	1	1
G 25	2200.004	9 FV C 10	chiavetta/key	1	1	1	1
G 26	2200.004	9 FV C 10	chiavetta/key	1	1	1	1
G 27	2200.004	9 FV C 10	chiavetta/key	1	1	1	1
G 28	3450.047	823 D 10	distanziale/spacer	1	1	1	
"	3450.048	823 S C 10	"				1
G 29	3203.015	9 FV C 10	dado/nut	1	1	1	1
G 30	9730.100	9 F 10	vite/screw M 8 X 1,25 X 25				1
G 31	7565.007	9 F C 10	rondella/washer	2	2	2	2
G 32	9732.375	9 S C 10	vite/screw M 8 X 1,25 X 50	4	4	4	
G 33	3203.015	9 FV C 10	dado/nut	1	1	1	1
G 34	3240.033	9 FV 10	dado/nut	4	4	4	4
G 35	7565.011	9 F C 10	rondella/washer	4	4	4	4
G 36	7625.019	9 S 10	rondella/washer	4	4	4	4
G 37+	6800.010	9 S C 10	prigioniero/stud M 10 X 25 (40)	4	4	4	4
G 38	8430.038	9 D C 10	spina/locking needle	4	4	4	4
G 39	1105.016	823 F C	albero ventola/fan spindle	1	1	1	1
G 40	3003.047	9 FV C	cuscinetto/ball bearing	1	1	1	1
G 41	2086.066	276 S	campana alternatore/alternator bell	1	1	1	1
G 42	9718.077	823 S C	ventola/blaster fan	1	1	1	1
G 43	7625.035	9 SV C 10	rondella/washer	1	1	1	1
G 44	9730.110	9 D C 10	vite/screw M 6 X 1 X 60	2	2	2	
G 45	6927.070	823 D C	protezione cinghie/belt guard	1	1	1	
"	6927.224	8330 S IC	"				1
G 46	7625.055	9 SV C 10	rondella/washer	1	1	1	1
G 47	6975.109	673 D C	puleggia/pulley	1			
"	6975.110	823 D C	"		1	1	
"	6975.117	933 D C	"				1
G 48	2440.089	673 FV C 2	cinghia/belt	1			
"	2440.088	823 FV C 2	"		1	1	
"	2440.139	933 FV C 2	"				1
G 49	2440.089	673 FV C 2	cinghia/belt	1			
"	2440.088	823 FV C 2	"		1	1	
"	2440.139	933 FV C 2	"				1
G 50	9731.092	9 S 10	vite/screw M 8 X 1,25 X 14	4	4	4	4
G 51	3260.057	9 SV C 10	dado/nut	1	1	1	1
G 52	7530.020	276 S C 10	rondella/washer	1	1	1	1
G 53	5885.047	822 S C	mozzo/hub	1	1	1	1
G 54	6975.111	823 S C	puleggia/fan driving pulley	1	1	1	1
H 1	9485.092	823 N A	tubo lubrificazione/lubric.pipe			1	1
H 2	4670.022	9 N A 10	guarnizione/copper gasket			2	2
H 3	5953.060	824 N A	nipplo/nipple			2	2
H 4	9485.096	823 N A	tubo lubrificazione/lubric.pipe			1	1
H 5	4670.060	9 FVAC 10	guarnizione/copper gasket			1	1
H 6	1901.040	9 SVAC 10	bullone raccordo/connection bolt			1	1
H 7	4670.060	9 FVAC 10	guarnizione/copper gasket			1	1
H 8	7350.034	823 N A	radiatore/oil cooler			1	1
H 9	9485.072	673 S C	tubo lubrificazione/lub.pipe	1	1		
H 10	4670.058	9 FV C 10	guarnizione/copper gasket	3	3	3	3
H 11	4670.058	9 FV C 10	guarnizione/copper gasket	3	3	3	3
H 12	1901.054	9 FV C 10	bullone raccordo/connection bolt	3	3	3	3
H 13	1770.004	9 F C 10	bullone/bolt M 8 X 1,25 X 20			2	2
H 14	5401.098	821 N	manicotto/rubber sheating	1	1		
"	5401.073	823 N A	"			1	1
H 15	8545.130	824 N A	staffa/brace	1	1		
H 16	7625.020	9 S AC 10	rondella/washer			2	2
H 17	3240.033	9 FVA 10	dado/nut			2	2
H 18	1780.015	9 FVA 10	bullone/bolt M 10 X 1,5 X 70			2	2
H 19	9485.185	825 N I	tubo lubrificazione/lub.pipe			1	1
H 20+	4160.011	823 SV C 10	ghiera/ring nut	2	2	1	1
H 21	7330.128	822 SV C	raccordo/connection	1	1	1	1
Motore/Engine	5LD 675-3	Versione/Version	710212				
"	5LD 824-3/B	"	726780				
"	5LD 825-3	"	710503				
"	5LD 930-3	"	718372				



Pos.	Matricola/Part No.	Note/Remarks	Q.ty/Eng.
H 22	4670.058 9 FV C 10	guarnizione/copper gasket	1 1 1 1
H 23	5400.093 2760 N 10	manicotto/rubber sheathing	2 2 2 2
H 24	3617.023 2760 D C 10	fascetta/strip fixing	2 2 2 2
H 25	9455.062 823 D C	tubo lubrificazione/lub.pipe	1 1 1 1
H 26	7555.008 9 FV C 10	rondella/washer	1 1 4 4
H 27	3240.020 9 SV C 10	dado/nut	1 1 2 2
H 28	3240.018 9 FV 10	dado/nut	1 1 3 3
H 29	6780.045 9 S 10	prigioniero/stud M 8 X 12 (24)	1 1 3 3
H 30	7565.007 9 F C 10	rondella/washer	1 1 3 3
H 31	4775.255 824 N A	guarnizione/rubber gasket	1 1 1 1
H 32	8545.138 823 N A	staffa/brace	1 1 1 1
H 33	1770.005 9 F 10	bullone/bolt M 8 X 1,25 X 22	1 1 2 2
H 34	=3740.032 276 FV C	FILTRO OLIO/OIL FILTER (Pos. 34-35)	1 1 1 1
H 35+	2175.036 276 FV C	cartuccia olio/oil filter element	1 1 1 1
H 36+	4670.016 9 FV C 10	guarnizione/copper gasket	1 1 1 1
H 37	8965.037 9 F C 10	tappo/plug	1 1 1 1
H 38	4670.058 9 FV C 10	guarnizione/copper gasket	1 1 1 1
H 39	1200.038 9 FV C 10	anello OR/rubber oil seal	1 1 1 1
H 40	4670.036 9 FV C 10	guarnizione/copper gasket	1 1 1 1
H 41	4936.082 823 N A	ingranaggio/gearwheel	1 1 1 1
H 42	9730.034 9 F C 10	vite/screw M 8 X 1,25 X 55	1 1 1 1
H 43	7555.007 9 DV C 10	rondella/washer	2 2 2 2
H 44	8965.021 9 S C 10	tappo/plug	1 1 1 1
H 45	4670.058 9 FV C 10	guarnizione/copper gasket	1 1 1 1
H 46	9730.040 9 D 10	vite/screw M 8 X 1,25 X 80	2 2 2 2
H 47	4730.024 832 DV C 10	guarnizione/gasket	1 1 1 1
H 48	6370.124 673 N	piastra interm./intermediate plate	1 1 1 1
"	6370.187 824 N A	" " " "	1 1 1 1
H 49	4670.022 9 N A 10	guarnizione/copper gasket	2 2 2 2
H 50	5953.060 824 N A	nipplo/nipple	2 2 2 2
H 51	1400.027 276 F C 10	asta livello/dipstick	1 1 1 1
"	1400.055 832 F C 10	" " " "	1 1 1 1
"	1400.122 9330 D C	" " " "	1 1 1 1
H 52	7701.009 9 N 10	rondella/washer	1 1 1 1
H 53	4670.016 9 FV C 10	guarnizione/copper gasket	1 1 1 1
H 54+	vedi/see Pos. 56	1 1 1 1
H 55+	2200.002 9 S C 10	chiavetta/key	1 1 1 1
H 56	=6605.051 824 S C	POMPA OLIO/OIL PUMP std.	1 1 1 1
"	=6605.072 824 N	" " " -1,00 (Pos. 54-55-56-57-69-70-71)	1 1 1 1
H 57+	1200.038 9 FV C 10	anello OR/rubber oil seal	1 1 1 1
H 58	7555.007 9 DV C 10	rondella/washer	2 2 2 2
H 59	4730.024 832 DV C 10	guarnizione/gasket	1 1 1 1
H 60	9027.007 9 N	tappo/plug	1 1 1 1
H 61	4670.014 276 SV C 10	guarnizione/copper gasket	1 1 1 1
H 62	4670.051 822 DV C 10	guarnizione/copper gasket	1 1 1 1
H 63	3740.057 673 D C	filtro olio/oil filter	1 1 1 1
"	3740.054 823 D C	" " " "	1 1 1 1
"	3740.062 9330 D C	" " " "	1 1 1 1
H 64	3240.018 9 FV 10	dado/nut	1 1 1 1
H 65	7625.012 9 FV C 10	rondella/washer	1 1 1 1
H 66	1770.002 9 FV 10	bullone/bolt M 8 X 1,25 X 16	1 1 1 1
H 67	4600.094 277 SV C 10	guarnizione/gasket	1 1 1 1
H 68	4670.058 9 FV C 10	guarnizione/copper gasket	1 1 1 1
H 69+	9730.026 9 F 10	vite/screw M 8 X 1,25 X 20	2 2 2 2
H 70+	7555.007 9 DV C 10	rondella/washer	2 2 2 2
H 71+	9765.055 9 N 10	vite/screw M 12 X 1,25 X 10	1 1 1 1
H 72	5111.008 276 DV C 10	lamierino/safety plate	1 1 1 1
H 73	1200.034 9 FV C 10	anello OR/rubber oil seal	1 1 1 1
H 74	=6645.119 277 D C	PORTINA DI FONDO/OIL PAN	1 1 1 1
"	=6645.121 833 D C	" " " " (Pos. 74-88-89)	1 1 1 1
H 74	6647.084 933 D C	portina di fondo/oil pan	1 1 1 1
H 75	3240.043 9 DV C 10	dado/nut	1 1 1 1
H 76	1862.067 823 N	bullone/bolt	1 1 1 1
H 77	9730.100 9 F 10	vite/screw M 8 X 1,25 X 25	2 2 2 2
H 78	7555.007 9 DV C 10	rondella/washer	2 2 2 2
H 79	1901.051 9 FV C 10	bullone raccordo/connection bolt	1 1 1 1
H 80	4670.058 9 FV C 10	guarnizione/copper gasket	1 1 1 1
H 91	9495.022 276 S C	tubo lubrificazione/lub.oil pipe	1 1 1 1
Motore/Engine	5LD 675-3	Versione/Version 710212	
"	" 5LD 824-3/B	" " 726780	
"	" 5LD 825-3	" " 710503	
"	" 5LD 930-3	" " 718372	



Pos.	Matricola/Part No.	Note/Remarks	Q.ty/Eng.
H 82	1901.051	9 FV C 10 bullone raccordo/connection bolt	1 1 1 1
H 83	4670.058	9 FV C 10 guarnizione/copper gasket	1 1 1 1
H 84	4670.058	9 FV C 10 guarnizione/copper gasket	1 1 1 1
H 85	1930.034	276 D C 10 bullone/bolt	1 1 1 1
H 86	1770.004	9 F C 10 bullone/bolt M 8 X 1,25 X 20	12 12 12
"	1770.006	9 S 10 " " M 8 X 1,25 X 25	14
H 87	7555.029	9 N 10 rondella/washer	14 14 14
"	7625.010	9 FV C 10 " "	14
H 88+	4670.016	9 FV C 10 guarnizione/copper gasket	1 1 1 2
H 89+	8965.005	9 FV C 10 tappo/oil plug	1 1 1 2
H 90	1770.002	9 FV 10 bullone/bolt M 8 X 1,25 X 16	2 2 2
I 1+	5550.015	276 SV C 10 molla/spring	1 1 1 1
I 2+	5270.081	276 D C 10 leva/lever	1 1 1 1
I 3+	7625.010	9 FV C 10 rondella/washer	1 1 1 1
I 4+	8430.023	9 S C 10 spina/locating pin	1 1 1 1
I 5	2380.090	276 S C cilindretto/fuel device	1
"	2380.091	276 D C " "	1
I 6+	3240.008	9 FV 10 dado/nut	1 1 1 1
I 7+	1760.028	9 N 10 bullone/bolt M 6 X 1 X 35	1 1 1 1
"	1760.041	9 D C 10 " " M 6 X 1 X 40	1
I 8+	1970.071	276 N 10 bussola/sleeve	2 2 2 2
I 9+	1200.001	9 FV C 10 anello OR/rubber oil seal	1 1 1 1
I 10+	1760.007	9 S 10 bullone/bolt M 6 X 1 X 25	2 2 2 2
I 11+	7625.007	9 S C 10 rondella/washer	1 1 1 1
I 12+	5680.040	276 S C 10 molla/spring	1 1 1 1
I 13+	5270.082	276 S C leva/lever	1 1 1 1
I 14+	7625.059	9 D C 10 rondella/washer	2 2 2 2
I 15+	3240.008	9 FV 10 dado/nut	2 2 2 2
I 16+	7625.007	9 S C 10 rondella/washer	1 1 1 1
I 17+	1165.001	9 S 10 anello/circlip	1 1 1 1
I 18+	6110.075	822 D C perno/pin	1 1 1 1
I 19+	5270.045	276 N 10 leva/lever	1 1 1 1
I 20	3240.063	9 N 10 dado/nut	1 1 1 1
I 21+	1760.023	9 N 10 bullone/bolt M 6 X 1 X 30	1 1 1 1
I 22+	3240.008	9 FV 10 dado/nut	1 1 1 1
I 23+	1770.001	9 FV 10 bullone/bolt M 8 X 1,25 X 12	1 1 1 1
I 24+	7555.004	9 FV C 10 rondella/washer	2 2 2 2
I 25+	6141.021	276 N perno/pin	1 1 1 1
I 26+	1760.001	9 FV 10 bullone/bolt M 6 X 1 X 10	1 1 1 1
I 27+	8430.005	9 D C 10 spina/locating pin	1 1 1 1
I 28+	6760.004	9 D 10 prigioniero/stud M 6 X 14 (23)	2 2 2 2
I 29+	8430.002	9 S C 10 spina/locating pin	1 1 1 1
I 30+	8430.023	9 S C 10 spina/locating pin	1 1 1 1
I 31+	3200.015	9 FV C 10 dado/nut	1 1 1 1
I 32+	1862.009	276 N bullone/bolt	1 1 1 1
I 33+	7565.004	9 F C 10 rondella/washer	1 1 1 1
I 34+	1240.002	9 SV 10 anello seeger/snap ring	1 1 1 1
I 35	4680.036	276 DV C 50 guarnizione/gasket	1 1 1 1
I 36+	3240.008	9 FV 10 dado/nut	1 1 1 1
I 37+	1200.081	9 D 10 anello OR/rubber oil seal	1 1 1 1
I 38+	4445.003	9 SV C 10 guarnizione/gasket	1 1 1 1
I 39+	3512.011	822 D C 10 distanziale/spacer	1 1 1 1
I 40+	3000.004	9 S C cuscinetto/ball bearing	1 1 1 1
I 41+	vedi/see Pos. 57	
I 42+	6141.023	276 D C 10 perno/pin	1 1 1 1
I 43+	7565.004	9 F C 10 rondella/washer	4 4 4 4
I 44+	5201.005	276 S leva/lever	1 1 1 1
I 45	=5200.199	822 S LEVA COMANDO/CONTROL LEVER (Pos. 2-3-18-32-33-34-45)	1 1 1 1
I 46+	5655.048	904 SV C 10 molla/spring	1 1 1 1
I 47	=7865.085	822 F C SCATOLA COMANDO/CONTROL HOUSING (Pos. 1-2-3-4-6-7-8-9-10-11-12-13- 14-15-18-19-21-22-23-24-25-26-27- 28-29-32-33-34-36-37-38-39-40-45- 46-47-48-49-50-51)	1 1 1 1
I 48+	1760.027	9 N bullone/bolt	1 1 1 1
I 49+	3000.004	9 S C cuscinetto/ball bearing	1 1 1 1
I 50	=8615.083	822 S SUPPORTO PERNO/JOURNAL SUPPORT (Pos. 37-38-39-40-49-50)	1 1 1 1
Motore/Engine	5LD 675-3	Versione/Version 710212	
"	5LD 824-3/B	" " 726780	
"	5LD 825-3	" " 710503	
"	5LD 930-3	" " 718372	



Pos.	Matricola/Part No.	Note/Remarks	Q.ty/Eng.			
I 51+	5200.172 822 S C	leva/lever	1	1	1	1
I 52+	5680.053 276 S C 10	molla/spring	1	1	1	1
I 53	=2515.070 276 F C	COMANDO ACCELERATORE/HAND CONTROL (Pos. 16-17-30-31-41-42-43-44-52-53-54-55-56-57)	1	1	1	1
I 54+	1760.010 9 N 10	bullone/bolt M 6 X 1 X 30	4	4	4	4
I 55+	8430.023 9 S C 10	spina/locating pin	1	1	1	1
I 56+	2135.056 276 N 10	cappuccio/cap	1	1	1	1
I 57	=5200.244 276 D TC	LEVA COMANDO STOP/STOP CONTROL LEVER (Pos. 41-57)	1	1	1	1
L 1	3206.016 276 FV C 10	dado/nut	10	10	10	10
L 2+	8506.003 904 S C 10	squadretta/angle bracket	3	3	3	3
L 3+	9732.064 9 S 10	vite/screw M 8 X 1,25 X 30	6	6	6	6
L 4	=2125.081 276 S C	CAPPELLO BILANC./ROCKER BOX CAP (Pos. 2-3-4)	3	3	3	3
L 5	4680.040 276 FV C 50	guarnizione/gasket 0,50	3	3	3	3
L 6+	6300.020 6720 D C	piastrina/plate	3	3	3	3
L 7+	9730.008 9 D C 10	vite/screw M 6 X 1 X 10	3	3	3	3
L 8+	6045.022 276 FV C	perno bilancieri/rocker arm shaft	3	3	3	3
L 9+	1200.030 9 FV C 10	anello OR/rubber oil seal	3	3	3	3
L 10	=4330.019 276 F C	GRUPPO BILANC./ROCKER ARM ASS.Y (Pos. 7-8-9-10-11-12-17-18-22-23)	3	3	3	3
L 11+	vedi/see Pos. 10				
L 12+	3240.010 9 FV C 10	dado/nut	3	3	3	3
L 13+	4845.164 276 FVICR10	guida v.scar./exh.v.guide std.	3	3	3	3
"	4845.165 276 FVICR10	" " " +0,50	3	3	3	3
L 14	7625.227 9 N 10	rondella/washer	12	12	12	12
L 15+	1160.004 276 FV C 10	anello/circlip	6	6	6	6
L 16+	4845.162 276 FVICR10	guida v.asp./inlet v.guide std.	3	3	3	3
"	4845.163 276 FVICR10	" " " +0,50	3	3	3	3
L 17+	9820.080 715 S C 10	vite/screw	3	3	3	3
L 18+	3240.008 9 FV 10	dado/nut	3	3	3	3
L 19+	4570.008 6720 DV C 50	guarnizione/gasket	3	3	3	3
L 20+	7555.004 9 FV C 10	rondella/washer	6	6	6	6
L 21+	6990.011 9 F C 10	tappo/plug	3	3	3	3
L 22+	4670.062 9 FV C 10	guarnizione/copper gasket	3	3	3	3
L 23+	9850.045 276 S C	vite/screw	6	6	6	6
L 24+	2135.063 276 FV C 10	cappello/cap	3	3	3	3
L 25	=9200.135 672 S C	TESTA COMPLETA/CYLINDER HEAD ASS.Y	3			
"	=9200.137 822 S C	" " (Pos. 6-7-8-9-10-11-12-13-15-16-17-18-19-20-21-22-23-24-25-26-28-29-30-31-32-33-34-35-36-F 34)		3	3	3
L 25	=9200.136 672 S C	TESTA SEMICOMPL./CIL.HEAD PART. ASS.Y	3			
"	=9200.138 822 S C	" " (Pos. 6-13-15-16-19-20-21-25-26-28-29-30-31-F 34)		3	3	3
L 26+	8000.075 672 FV CR	sede v.scarico/exhaust v.seat	3			
"	8000.073 822 FV CR	" "		3	3	3
L 27	4730.096 672 SV C 10	guarnizione testa/head gasket 0,70	3			
"	4730.083 672 DV C 10	" " 0,80	3			
"	4730.097 672 DV C 10	" " 0,90	3			
"	4730.098 672 SV C 10	" " 1,00	3			
"	4730.135 672 DV C 10	" " 1,10	3			
"	4730.104 822 SV C 10	" " 0,70		3	3	
"	4730.023 832 FV C 10	" " 0,80		3	3	
"	4730.105 822 DV C 10	" " 0,90		3	3	
"	4730.094 822 SV C 10	" " 1,00		3	3	
"	4730.136 822 SV C 10	" " 1,10		3	3	
"	4730.100 933 FV C 10	" " 0,70				3
"	4730.101 933 DV C 10	" " 0,80				3
"	4730.102 933 DV C 10	" " 0,90				3
"	4730.106 933 DV C 10	" " 1,00				3
"	4730.137 933 FV C 10	" " 1,10				3
Motore/Engine	5LD 675-3	Versione/Version 710212				
"	5LD 824-3/B	" " 726780				
"	5LD 825-3	" " 710303				
"	5LD 930-3	" " 718372				



Pos.	Matricola/Part No.	Note/Remarks	Q.ty/Eng.				
L 28+	8000.074	672 FV CR	sede v.aspir./inlet v.seat	3			
"	8000.072	822 FV CR	sede v.aspir./inlet v.seat	3	3	3	3
L 29+	6780.057	9 FV C 10	prigion.scar./exhaust stud M 8 X 30	6	6	6	6
L 30+	6780.049	9 D C 10	prigion.aspir./inlet stud M 8 X 20	6	6	6	6
L 31+	1760.005	9 FV 10	bullone/bolt M 6 X 1 X 16	6	6	6	6
L 32+	6410.023	276 F C 10	piattello/retainer with half-collets	6	6	6	6
L 33+	9685.019	276 FV CR	valvola scarico/exhaust valve	3			
"	9685.053	822 FV CR	"	3	3	3	3
L 34+	6410.020	276 F C 10	piattello/cup	6	6	6	6
L 35+	5755.040	276 FV C 10	molla/spring	6	6	6	6
L 36+	9652.015	276 FV CR	valvola aspirazione/inlet valve	3	3	3	3
"	9652.041	822 FV CR	"	3	3	3	3
M 1	7100.155	933 D C	puleggia/external alternator pulley				1
M 2	9718.035	2760 D C	ventola alternatore/alternator fan				1
M 3	1157.046	2760 FVIC	altern.esterno/voltage alternator				1
M 4	5400.060	2790 N	manicotto/rubber shafting				1
M 5+	1780.066	9 N 10	bullone/bolt M 10 X 1,5 X 70	1	1	1	
M 6+	7670.095	823 N 10	rondella/washer	1	1	1	
M 7+	1240.051	9 DV C 10	anello seeger/snap ring	1	1	1	
M 8+	3010.095	923 S C	cuscinetto/ball bearing	1	1	1	
M 9+	7051.061	823 D C	puleggia galoppino/jockey pulley	1	1	1	
M 10+	3466.037	823 D C	distanziale/spacer	1	1	1	
M 11+	7500.025	823 N 10	rondella/washer	1	1	1	
M 12	1770.039	9 S C 10	bullone/bolt M 8 X 1,25 X 28				1
M 13	8546.048	360 D C	staffa/brace				1
M 14	7625.061	9 D C 10	rondella/washer				1
M 15	7565.007	9 F C 10	rondella/washer				2
M 16	3240.018	9 FV 10	dado/nut				1
M 17	8903.090	933 D C	supporto/alternator support				1
M 18	6800.004	9 F C 10	prigioniero/stud M 10 X 20 (35)	2	2	2	
M 19	5231.053	923 D C	perno/pin	1	1	1	
M 20+	7565.011	9 F C 10	rondella/washer	1	1	1	
M 21+	3240.033	9 FV 10	dado/nut	1	1	1	
M 22	8490.088	9330 N	squadretta/angle bracket				1
M 23	2501.031	933 D C	colonna/hollowstud				1
M 24	1770.056	9 S C 10	bullone/bolt M 8 X 1,25 X 18				1
M 25	7565.007	9 F C 10	rondella/washer				1
M 26	6780.012	9 DV C 10	prigioniero/stud M 8 X 25 (37)				4
M 27	3617.053	276 N	fascetta/fixing strip				1
M 28	3617.024	710 S 10	fascetta/fixing strip	1	1	1	
M 29	7625.010	9 FV C 10	rondella/washer	1	1	1	
M 30	1770.051	9 FV 10	bullone/bolt M 8 X 1,25 X 12	1	1	1	
M 31	3240.033	9 FV 10	dado/nut	2	2	2	
M 32	7565.011	9 F C 10	rondella/washer	2	2	2	
M 33	7625.196	9 N 10	rondella/washer	2	2	2	
M 34	=4110.006	823 S C	GALOPPINO TENDICINGHIA/JOKEY ASS.Y (Pos. 5-6-7-8-9-10-11-19-20-21-34)	1	1	1	
M 34+	6360.055	823 D C	piastra/plate	1	1	1	
M 35	1780.006	9 FV 10	bullone/bolt M 10 X 1,5 X 30				1
M 36	2615.021	9040 F C	coperchio/cover	1	1	1	
M 37	3240.018	9 FV 10	dado/nut				4
M 38	7565.007	9 F C 10	rondella/washer				4
M 39	1760.032	9 S C 10	bullone/bolt M 6 X 1 X 14	2	2	2	
M 40	7625.092	9 D C 10	rondella/washer	2	2	2	
M 41	1770.006	9 S 10	bullone/bolt M 8 X 1,25 X 25	1	1	1	
M 42	3617.021	5000 D 10	fascetta/strip fixing	1	1	1	
M 43	5400.046	276 F C 10	manicotto/rubber sheathing	1	1	1	
M 44	1157.158	822 FVIC	alternatore/voltage alternator	1	1	1	
M 45	6491.005	2830 FV C	pipetta/pipe elbow	1	1	1	
M 46	2145.014	276 FV C	cappuccio/rubber cap	1	1	1	
M 47	6740.153	2830 FVAC 10	presa regol./inlet regul.Saprica	1	1	1	
"	6740.154	2830 SVAC 10	presa regol./inlet regul.Ducaui	1	1	1	
M 48	9730.242	9 DV C 10	vite/screw M 8 X 1,25 X 16	2	2	2	
M 49	7362.238	2830 FVIC	regolat.tens./voltage regulator	1	1	1	
M 50+	6491.013	3600 FV C 10	pipetta/pipe elbow	1	1	1	
M 51	= 6745.031	9040 FV C	PRESSOSTATO/OIL PRESSURE SWITCH (Pos. 50-51)	1	1	1	
M 52	5041.020	2760 FV C	interruttore/key switch	1	1	1	
M 53	2750.111	2760 F C	coperchio/switch cover	1	1	1	
M 54	6612.063	9040 S C	spia olio/pressure oil warning	1	1	1	
Motore/Engine	5LD 675-3	Versione/Version	710212				
"	5LD 824-3/B	"	726780				
"	5LD 825-3	"	710503				
"	5LD 930-3	"	718372				



Pos.	Matricola/Part No.	Note/Remarks	Q.ty/Eng.		
M 55	6612.064 9040 S C	spia batteria/battery warning	1	1	1
M 56	5175.119 9040 F C 10	lampadina/lamp	2	2	2
M 57	2900.070 9040 F C	cruscotto/dashboard	1	1	1
M 58	1770.004 9 F C 10	bullone/bolt M 8 X 1,25 X 20	3	3	3
M 59	7565.007 9 F C 10	rondella/washer	4	4	4
M 60	8902.094 2760 D C	supporto/support	1	1	1
M 61	5400.093 2760 N 10	manicotto/rubber sheathing	2	2	2
M 62	3617.020 2760 S C 10	fascetta/strip fixing	1	1	1
M 63	5840.067 278 F I	mot.avv./start.engine HP 2,5 Bosch	1	1	1
M 64	3240.048 9 FV C 10	dado/nut	2	2	2
M 65	7565.013 9 S C 10	rondella/washer	2	2	2
M 66	7625.026 9 S 10	rondella/washer	2	2	2
M 67+	6820.014 9 D 10	prigioniero/stud M 8 X 30 (48)	2	2	2
M 68	4670.014 276 SV C 10	guarnizione/copper gasket	1	1	1
N 1	=8180.067 673 FV CR	SERIE GUARNIZIONI/GASKET SET	1		
"	=8180.064 823 FV CR	" "	1	1	
"	=8180.069 933 SV CR	" "			1
		(Pos.A 5-A 9-A19-A22-B 9-C 7-E 7-E12-E14-E15-E24-E37-F62-F115-H47-H59-H67-T35-T. 5-T.19-T.27)			
N 2	=8150.011 672 FVAC	SERIE ANELLI/O RING SET (Pos.D10-D16-E20-H39-H73-L 9-L24)	1	1	1
N 3	=8190.011 830 FV C	SERIE LAMIERINI/LOCK.SET (Pos.C12-C19-D 2-D 6-D28-D44-D48-D55-H72)	1	1	1
Motore/Engine 5LD 675-3			Versione/Version 710212		
" " 5LD 824-3/B			" " 726780		
" " 5LD 825-3			" " 710503		
" " 5LD 930-3			" " 718372		

INDICE DELLE MODIFICHE/IMPROVEMENTS INDEX

Motori/Engines Gr. 5-3 cyl.



Pos.	Nuova matricola New Part No.	Vecchia matricola Old Part.No.	Vedi Circ.Tec. See Serv.Lett.	Q.ty/Eng.			
A 2	=3700.346 832 SVIC	3703.047 822	50006	1	1	1	1
A 51	5496.180 276 SVAC	50006	1	1	1	1
B 2	=6500.664 822 FVAC	6500.154 822	1493, 50004	3	3	3	3
"	=6500.665 822 F ACR	6500.155 822	1493, 50004	3	3	3	3
"	=6500.698 822 F ACR	6500.158 822	1493, 50004	3	3	3	3
B 3	8211.138 822	8210.067 832	1493	3	3	3	3
"	8211.212 822 FVAC	8211.138 822	CTVAR	3	3	3	3
"	8211.139 822 F ACR	8210.068 832	1493	3	3	3	3
"	8211.140 822 F ACR	8210.069 832	1493	3	3	3	3
B 10	3203.034 9 FVIC 10	3240.032 9	1457	6	6	6	6
D 9	9520.049 673 FVAC	9520.028 276	1454	6	6	6	6
"	9520.050 822 FVAC	9520.032 832	1454	6	6	6	6
D 10	1261.069 672 FVAC 10	1261.046 276	1454	6	6	6	6
D 12	7625.100 672 S AC 10	1454	6	6	6	6
D 13	5801.135 672 SVAC 10	1454	6	6	6	6
D 16	1261.069 672 FVAC 10	1261.046 276	1454	6	6	6	6
D 17	7625.100 672 S AC 10	1454	6	6	6	6
D 45	4936.080 823 N A	4936.071 822	1489	1	1	1	1
D 46	4936.081 823 N A	1489	1	1	1	1
F 9	8010.002 260	CTVAR	3	3	3	3
F 30	9375.687 930 SVIC	9372.018 277	50002	1	1	1	1
F 31	9375.689 930 FVIC	9372.007 276	50002	1	1	1	1
F 32	9375.688 930 FVIC	9372.006 276	50002	1	1	1	1
F108	1970.055 261	CTVAR	1	1	1	1
F111	9865.040 261	CTVAR	1	1	1	1
G 5	5066.164 823 N A	5066.045 823	1489	1	1	1	1
G 45	6927.224 8330 S IC	6927.080 933	CTVAR	1	1	1	1
H 1	9485.092 823 N A	9485.068 823	1489	1	1	1	1
H 2	4670.022 9 N A 10	1489	2	2	2	2
H 3	5953.060 824 N A	1489	2	2	2	2
H 4	9485.096 823 N A	9485.067 823	1489	1	1	1	1
H 5	4670.060 9 FVAC 10	1489	1	1	1	1
H 6	1201.340 9 SVAC 10	1489	1	1	1	1
H 7	4670.060 9 FVAC 10	1489	1	1	1	1
H 8	7350.034 823 N A	7350.013 823	1489	1	1	1	1
H 14	5401.073 823 N A	5390.013 823	1489	1	1	1	1
H 15	8545.130 824 N A	1489	1	1	1	1
H 16	7625.020 9 S AC 10	1489	2	2	2	2
H 17	3240.033 9 FVA 10	1489	2	2	2	2
H 18	1780.015 9 FVA 10	1489	2	2	2	2
H 19	9485.185 825 N I	9485.070 823	1489	1	1	1	1
"	"	9485.120 823	CTVAR	1	1	1	1
H 31	4775.255 824 N A	1489	1	1	1	1
H 32	8545.136 823 N A	1489	1	1	1	1
H 41	4936.082 823 N A	4936.034 276	1489	1	1	1	1
H 48	6370.187 824 N A	6371.063 832	1489	1	1	1	1
H 49	4670.022 9 N A 10	4670.019 9	1489	2	2	2	2
H 50	5953.060 824 N A	5953.036 832	1489	2	2	2	2
I 57	=5200.244 276 D IC	5201.003 276	1468	1	1	1	1
L 13	4845.164 276 FVICR10	4845.057 276	1485	3	3	3	3
"	4845.165 276 FVICR10	4845.165 276	1485	3	3	3	3
L 16	4845.162 276 FVICR10	4845.056 276	1484	3	3	3	3
"	4845.163 276 FVICR10	4845.040 276	1484	3	3	3	3
M 3	1157.046 2760 FVIC	1157.025 2760	5153	1	1	1	1
M 44	1157.158 822 FVIC	1157.039 904	5151	1	1	1	1
M 47	6740.153 2830 FVAC 10	6740.088 276	5151	1	1	1	1
"	6740.154 2830 SVAC 10	6740.090 276	5151	1	1	1	1
M 49	7362.238 2830 FVIC	7362.066 9040	5151	1	1	1	1
M 63	5840.067 278 F I	5840.045 278	5153	1	1	1	1

Motore/Engine	5LD 675-3	Versione/Version	710212
"	5LD 824-3/B	"	726780
"	5LD 825-3	"	710503
"	5LD 930-3	"	718372

LOMBARDINI MOTORI F.I.M. S.p.a.

Edizione del/Issue of 15.05.1992