

**RICAMBI PER MOTORE STANDARD.
PER APPLICAZIONI SPECIALI CONSULTARE
IL CATALOGO PRESSO I CENTRI ASSISTENZA
E RICAMBI.**

**PIECES POUR DES MOTEURS STANDARD.
POUR LES ADAPTATIONS CONSULTER
LE CATALOGUE AUPRES
DES AGENTS SERVICE.**

**SPARE PARTS FOR STANDARD
FOR SPECIAL APPLICATIONS &
CATALOG AT SERVICE CENTER**

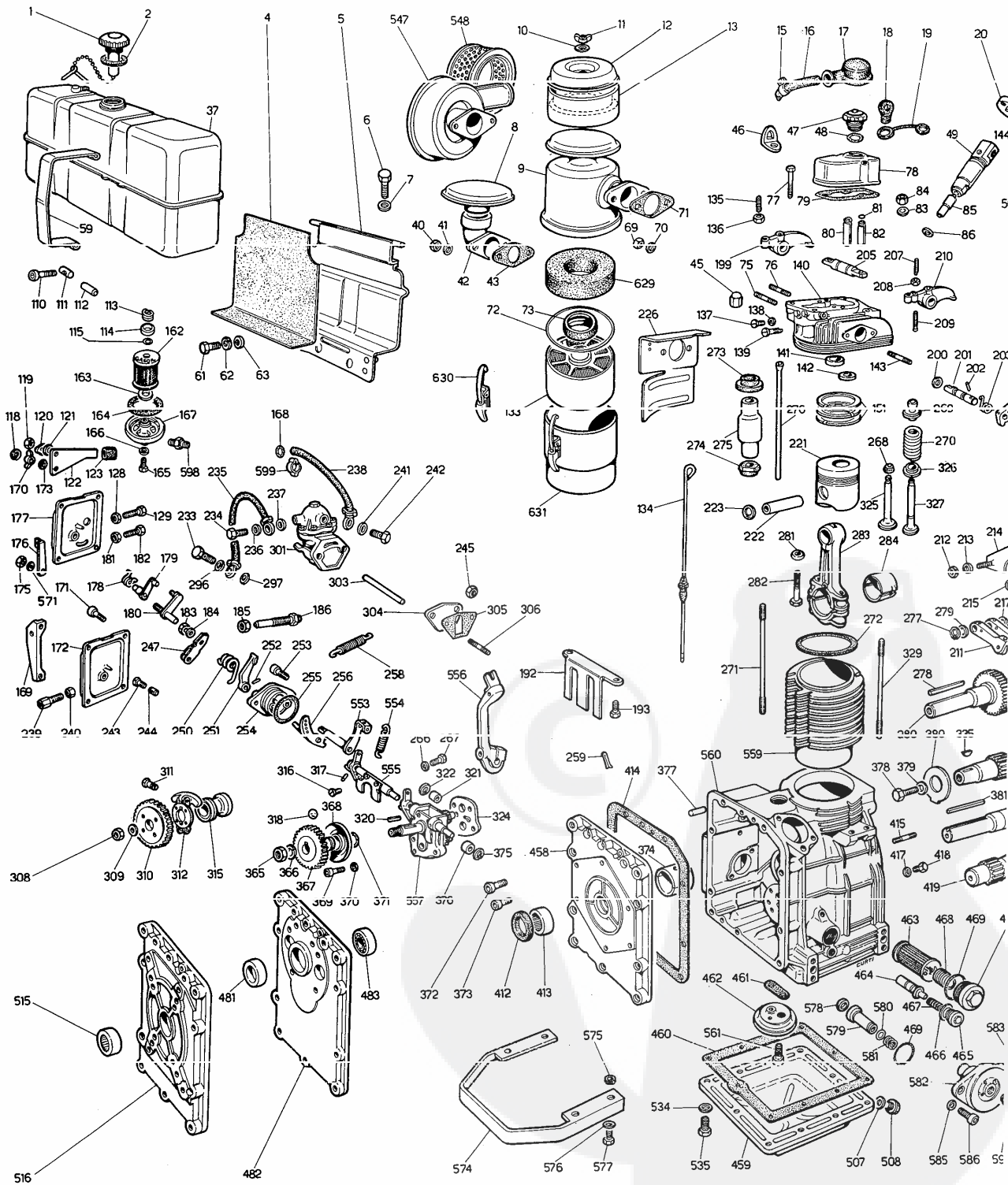

R STANDARD ENGINE.
'LICATIONS SEE MASTER
VICE CENTERS.

ERSATZTEILE FÜR STANDARD-MOTOREN.
FÜR SONDERANFERTIGUNGEN SIEHE
ERSATZTEILKATALOG BEI SERVICE
WERKSTÄTTEN.

REPUESTOS PARA MOTORES STANDARD.
PARA APLICACIONES VEASE CATALOGO
EN LAS ESTACIONES SERVICE.

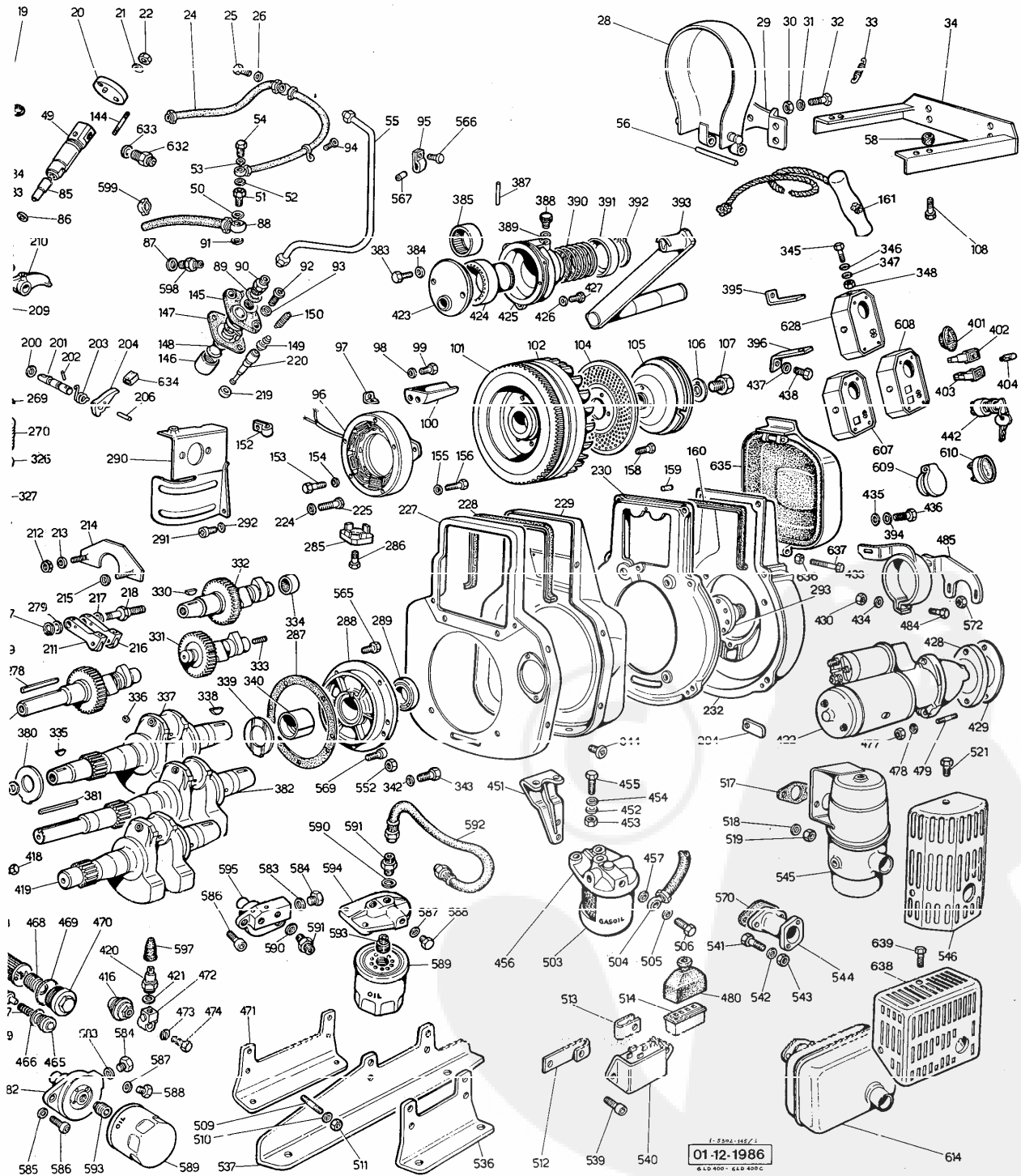

 LEGENDA TAVOLA RICAMBI MATR.
 SPARE PARTS TABLE P.NO. ... 1.5302.145
 TABLEAU PIECES DETACHEES REF.

 01.06.1992

MOTORI TIPO	6LD 325	6LD 325/C	CILINDRO STACCATO
ENGINES TYPE			DETACHEABLE CYLINDER
MOTEURS TYPE	6LD 360		CYLINDRE ENLEVABLE
MOTOREN TYP			AUSWECHSELBAREN ZYLINDER
MOTORES TIPO	6LD 400	6LD 400/C	CILINDRO SUELTO

Vedi/See/Voir

Libretto uso e manutenzione
 Use-Maintenance booklet 1.5302.077
 Livret Emploi-Entretien
 Libretto Service
 Service directory 1.7968.002
 Reseau S.A.V.
 Serie accessori
 Accessory set 283.8140.080
 Jeu accessoires

 Note/Remarks/Remarques

- F - alta movimentazione/fast moving part/haut mouvement.
- S - media movimentazione/medium moving part/moyen mouvement.
- D - bassa movimentazione/slow moving part/bas mouvement.
- E - ad esaurimento/exhausting part/piece en epuisement.
- N - particolare nuovo o fornito su richiesta/
 -new part or part supplied upon request/
 -piece nouvelle ou fournie sur demande.
- A - valido dal motore.../from eng.S.No.../{ partir du moteur...
 (vedi Circolare Tecnica/see Service Letter/voir Circ.Techn.)
- B - valido fino al motore.../up to eng.S.No.../jusqu'au moteur...
 (vedi Circolare Tecnica/see Service Letter/voir Circ.Techn.)
- I - intercambiabile/interchangeable.
 (vedi Circolare Tecnica/see Service Letter/voir Circ.Techn.)
- V - stock vitale per Officine Service.
 vital stock for Service Dealer.
 stock vital pour Stations Service.
- C - stock vitale per Costruttori,Esportatori,Enti di Stato.
 vital stock for Producers,Exporters,State Companies.
 stock vital pour Constructeurs,Export.,Institut.de l'Etat.
- R - stock vitale per Rettifica.
 vital stock for Grinding Workshops.
 stock vital pour Usines de Rectification.
- 10/50/2-q.ta minima fornibile/min.supplied q.ty/q.te min.fournie.
- = gruppo completo/assembly/groupe complet.
- + componente del gruppo/assembly component/composant du groupe.

Serie guarnizioni/Gasket set	520.8180.092	6LD325-325/C
	530.8180.082	6LD360
	540.8180.063	6LD400-400/C

 Tipo motore/Engine type Blocco motore/Short block

6LD 325	CONIC.	5200.1560.192
6LD 360	CONIC.	5300.1560.177
6LD 360	EXT.4 SAE	5300.1560.178
6LD 360	EXT.A 3	5300.1560.179
6LD 360	EXT.9 SAE	5300.1560.180
6LD 400	CONIC.	5400.1560.141
6LD 400	EXT.4 SAE	5400.1560.142
6LD 400	EXT.A 3	5400.1560.143
6LD 400/C	CONIC.	5430.1560.149
6LD 400/C	EXT.4 SAE	5430.1560.150

 TECO/ATL/Assistenza Tecnica Lombardini

DESCRIZIONI NON IMPEGNATIVE
 SUBJECT TO MODIFICATIONS

FIG. NO.	MATRICOLA P.NO	Q.ta Q.ty	NOTE REMARKS	GR. 6 - 1.5302.145 Pag.02
1+2=	=2830.9043.025 FV C	1	TAPPO SERBATOIO/FUEL TANK CAP	
2+	2700.4650.056 DV C 10	1	guarnizione/gasket	
4	500.4701.010 FV C 10	1	guarnizione/gasket	
5	500.8866.053 F C	1	supp.serb.t.dist./gear side tank support	
6	9.1770.111 F C 10	2	bullone/bolt M 8	
7			
8	292.2135.094 S C	1	cappello/inlet cover	
9+72+73+133+629+630+631+=	=540.3700.111 FVIC =540.3700.112 DVIC	1 1	FILTRO ARIA CON CAPPELLOTO AIR CLEANER WITH AIR INLET COVER std. per motori con pompa alimentazione for engines with feed pump	
9+10+11+12+13+72+73+133+629+630+631+=	=540.3700.109 FVIC =540.3700.110 S IC	1 1	FILTRO ARIA CON PREFILTRO A CICLONE CYCLONIC TYPE AIR CLEANER std. per motori con pompa alimentazione for engines with feed pump	
10+	9.7555.004 FV C 10	1	rondella/washer	
11+	9.3200.002 FV C 10	1	dado/nut	
12+	500.2125.055 F C	1	cappello prefiltro/prefilter cover	
13+	500.1301.053 FV C 10	1	prefiltro/prefilter	
15+	2760.3617.020 S C 10	1	fascetta/strip fixing	
16+	5000.9601.044 FV C 10	1	tubo sfiato/breather pipe mm 500	
17+	2890.2145.003 FV C	1	cappuccio/cap	
18	270.9055.003 FV C 10	1	tappo/starter cap	
19	500.3695.038 F C 10	1	filo/wire	
20	500.3790.042 S IC	1	flangia/flange	
21			
22	9.3240.002 FV C 10	2	dado/nut	
24	500.9601.064 FV C 10	1	tubo spurgo/bleeding pipe (mm 530)	
25	9.1901.029 FVIC 10	1	bullone raccordo/connection bolt	
26	9.4670.058 FV C 10	2	guarnizione/copper gasket	
28+29+56=	=5000.6927.036 D	1	PROTEZIONE PULEGGIA PULLEY GUARD	
29+		vedi/see fig.No. 28+...	
30	9.3240.008 FV C 10	4	dado/nut	
31	9.7565.004 F C 10	4	rondella/washer	
32	9.1760.032 S C 10	4	bullone/bolt M 8 x 1 x 14	
33	5000.5725.034 S C 10	2	molla/spring	
34	5300.8903.052 D	1	supporto/support	
37+1+2=	=500.8103.038 F C	1	SERBATOIO COMPLETO/FUEL TANK std.	
40	9.3240.021 SV C 10	2	dado/nut	
41	9.7565.007 F C 10	2	rondella/washer	
42	5200.2942.019 S IC	1	curva scarico/exhaust pipe	
43+	500.1500.002 FV C 10	1	guarnizione/gasket	
45	9.3230.030 SV C 10	2	dado lato distribuzione/gear side nut	
46+	904.8506.003 S AC 10	1	squadretta/angle bracket	
47+48=	=270.9050.021 FV C	1	TAPPO SFIATO/BREATHER CAP std.	
47+15+16+17+48=	=2830.9050.029 FV C	1	TAPPO SFIATO/BREATHER CAP protetto/protected	
48+	9.1206.014 FVIC 10	1	anello OR/rubber oil seal	
49+85=	=540.6615.043 S IC =540.6615.044 D	1 1	PORTAPOLVERIZZATORE/NOZZLE HOLDER std. Bosch type	
50	9.4670.060 FVIC 10	1	guarnizione/copper gasket	
51	710.1901.012 FVIC 10	1	bullone raccordo/connection bolt	
52	9.4670.058 FV C 10	1	guarnizione/copper gasket	
53	9.4670.058 FV C 10	1	guarnizione/copper gasket	
54	9.1901.029 FVIC 10	1	bullone raccordo/connection bolt	
55	500.9372.090 FV C	1	tubo mandata comp./fuel delivery pipe	
56+		vedi/see fig.No. 28+...	
58	720.3527.004 F C 10	4	distanziale/spacer	
59+110+111=	=500.3617.010 F C 10	2	FASCETTA FISSAGGIO SERBATOIO FUEL TANK STRAP	
61	9.1770.111 F C 10	2	bullone/bolt M 8	

FIG. NO.	MATRICOLA P. NO	Q.ta Q.ty	NOTE REMARKS	GR. 6 = 1.5302.145 Pag. 03
62			
63			
69	9.3240.019 FV C 10	2	dado/nut	
70	9.7565.007 F C 10	2	rondella/washer	
71+	500.4500.092 FV C 10	2	guarnizione/gasket	
72+	500.4775.120 FVAC 10	1	guarnizione/gasket H=10 Diam.=135	
73+	500.1261.072 FVIC 10	1	anello ten./seal ring H=17,6 Diam.=54	
75+	9.6780.010 F 10	1	prigioniero/stud M 8 X 22 (34)	
76+	9.6780.071 SV C 10	1	prigioniero/stud M 8 X 28 (40)	
77+	9.9730.034 F C 10	2	vite/screw M 8 X 1,25 X 55	
78+46+77=	=540.2125.103 S C	1	CAPPELLO SCATOLA BILANCIERI ROCKER BOX CAP	
79+	540.4400.023 FV C 50	1	guarnizione/gasket 0,50	
80+	500.4845.071 E	1	guida v.asp./inlet v.guide std.	
"	500.4845.075 E	1	" " +0,50	
"	500.4845.166 FVICR10	1	" " std.	
"	500.4845.167 FVICR10	1	" " +0,50	
81+	500.1160.008 FV C 10	2	anello/circlip	
82+	500.4845.052 E	1	guida v.scar./exhaust v.guide +0,50	
"	500.4845.168 FVACR10	1	" " std.	
"	500.4845.169 FVACR10	1	" " +0,50	
83	9.7025.134 N 10	2	rondella lato volano/flywheel side washer	
84	9.3240.076 FV C 10	2	dado lato volano/flywheel side nut	
85+	395.6531.104 FVIC	1	polverizzatore/nozzle std.	
86	9.4670.005 FVBC 10	1	guarnizione/copper gasket 0,50 D=16,50	
"	9.4670.006 FVBC 10	2	" " 2,00 D=16,50	
"	9.4670.065 SVAC 10	1	" " 1,50 D=18,85	
87	9.4670.058 FV C 10	1	guarnizione/copper gasket	
88	500.9375.204 FVAC	1	tubo da serb.l.distr.a pompa in.(mm 142)	
89+	9.1200.031 FV C 10	1	pipe from gear side f.tank to inject.pump	
90+	271.7265.008 FV C 10	1	anello OR/rubber oil seal	
91	9.4670.060 FVIC 10	1	racordo/connection	
92	9.9730.100 F 10	2	guarnizione/copper gasket	
93	9.7625.010 FV C 10	2	vite/screw M 8 X 1,25 X 25	
94	9.9790.037 FV C 10	1	rondella/washer	
95	540.3617.078 N 10	1	vite/screw M 6 X 1 X 8	
96	283.1156.090 FVIC	1	fascetta/strip fixing	
"	5000.1156.098 FV C	1	alternatore/voltage alternator 12 V 12 A	
97	500.6275.076 D C 10	1	" " 12 V 4 A	
98	9.7555.004 FV C 10	2	piastra/plate	
99	9.9730.012 F C 10	2	rondella/washer	
100	5000.3350.065 S C	1	vite/screw M 6 x 1 x 20	
"	540.3350.090 S C	1	deflettore avv.el./el.start.deflector	
101+	530.2816.036 F AC	1	deflettore avv.man./hand-cr.st.deflector	
102+101=	=540.9880.143 S C	1	corona avviamento/crown gear	
"	=540.9880.144 S C	1	VOLANO+CORONA/FLYWHEEL+CROWN GEAR	
102	500.9881.055 S C	1	avv.el./el.start. 12V 4A 6LD325-360-400	
"	540.9880.123 S C	1	" " 12V 12A	
"	503.9882.002 D C	1	x 6LD325 std.	
"	543.9880.128 N	1	x 6LD360-400 std.& avv.man./hand-cr.start	
"	540.9880.129 N	1	e/and 6LD325 avv.man./hand-cr.start.	
"	543.9880.130 N	1	x 6LD325/C std.	
"	543.9880.130 N	1	x 6LD400/C std.& avv.man./hand-cr.start.	
"	543.9880.130 N	1	e/and 6LD325/C avv.man./hand-cr.start.	
104	500.5095.076 F C	1	x imp.luce con/senza avv.a manovella	
105	500.6960.069 FV C	1	lgh.syst.with/without hand-cr.start	
"	503.6960.083 S C	1	su/on 6LD325-360-400	
106	9.7626.043 S IC 10	1	x imp.luce con/senza avv.a manovella	
107	9.1800.030 F IC 10	1	lgh.syst.with/without hand-cr.start	
"	9.1800.029 D C 10	1	su/on 6LD325-360-400	
108	9.9730.027 F 10	4	x imp.luce con/senza avv.a manovella	
110+	9.9730.016 DV C 10	2	lgh.syst.with/without hand-cr.start	
111+	45.1557.019 F C 10	2	su/on 6LD325/C-400/C	
112	271.9600.057 FV C 10	2	lampiera/panel slide x avv.man./hand-cr.st.	
113+	273.5575.006 FV C 10	1	puleggia/pulley 6LD325-360-400 std.	
114+	273.3930.019 F C 10	1	" " 6LD325/C-400/C std.	
115+	9.1200.032 FV C 10	1	rondella/washer	
118+	9.1165.001 S 10	1	bullone/bolt 6LD325-360-400	
119+	9.3240.004 FV C 10	1	" " 6LD325/C-400/C	
120+	90.6330.057 F C 10	1	vite/screw M 8 X 1,25 X 25	
121+	9.7625.019 S 10	1	vite/screw M 6 X 1 X 35	
122+	500.5201.094 S C	1	blocchetto/nut	
123+	270.6550.010 D C 10	1	tubo/rubber spacer	
			molla/spring	
			fondello/cup	
			anello OR/rubber oil seal	
			anello/circlip	
			dado/nut	
			piastriina/safety plate	
			rondella/washer	
			leva/lever	
			pomello/knob	

FIG. NO.	MATRICOLA P. NO	Q.ta Q.ty	NOTE REMARKS	GR. 6 - 1.5302.145 Pag.04
128	9.3240.008 FV	10	1	dado/nut
129	9.1760.029 D C	10	1	bullone/bolt M 6 X 1 X 30
133+	500.5436.071 SVAC		1	massa/filtering element II=30 Diam.=110
134	500.1400.035 F C	10	1	asta livello/dipstick std. mm 385
"	5000.1400.072 D C		1	special mm 190
135+	500.9850.048 S C	10	1	vite/screw
136+	9.3240.008 FV	10	1	dado/nut
137			
138			
139+	715.9820.080 S C	10	1	vite/screw
140+75+76+80+81+82+				TESTA COMPLETA predisposta
139+141+142+143+144+				per decompressione
200+201+202+203+204+				CYLINDER HEAD preset for
206+269+270+325+326+				decompression
327+634=				
"	=540.9200.131 S C		1	
141+	283.8000.036 FVACR	10	1	sede v.aspiraz./inlet v.seat
142+	283.8000.037 FVACR	10	1	sede v.scarico/exhaust v.seat
143+	9.6780.068 S C	10	2	prigioniero/stud M 8 X 18 (30) std.
"	9.6780.069 F	10	2	per marm.a bauletto/for box form muffler
144+	9.6760.035 FV C	10	2	prigioniero/stud M 6 X 53 (65)
145+89+90=				POMPA INIEZIONE/INJECTION PUMP
"	=520.6590.136 D IC		1	x 6LD325-325/C std.
"	=520.6590.072 D C		1	" " Bosch type
"	=540.6590.073 F C		1	X 6LD360-400-400/C std.
146	500.7215.035 FV C		1	punteria/tappet
147+	500.4580.023 N	50	1	guarnizione/gasket 0,30
"	500.4580.024 N	50	1	" " 0,50
"	500.4580.029 N	50	1	" " 1,00
148	500.6000.036 FV C	10	1	pastiglia/tappet
149	500.9672.012 F C		1	valvolina mandata/delivery valve (mmc 25)
"	540.9672.029 D C		1	" " (mmc 15)
150	271.5755.034 SV C	10	1	molla/spring
151+	520.8211.078 FV C	10	1	std. x 6LD325-325/C serie segm./ring set
"	520.8211.079 F CR	10	1	+0,50 " " " "
"	520.8211.080 F CR	10	1	+1,00 " " " "
"	530.8211.045 FV C	10	1	std. x 6LD360 " " " "
"	530.8211.046 F CR	10	1	+0,50 " " " "
"	530.8211.047 F CR	10	1	+1,00 " " " "
"	540.8211.056 FV C	10	1	std. x 6LD400-400/C " " " "
"	540.8211.017 F CR	10	1	+0,50 " " " "
"	540.8211.018 F CR	10	1	+1,00 " " " "
152	5000.3617.021 D	10	1	fascetta/clamp x avv.el./el.st.12 V 4 A
"	530.3617.046 N		1	" " x avv.el./el.st.12 V 12 A
153	9.9730.012 F C	10	4	x avv.el./el.st.12 V 4 A-M 6X1X20
"	9.1760.001 FV	10	3	x " " 12 V 12 A-M 6X1X10
154	9.7555.004 FV C	10	4	rondella/washer x avv.el./el.start 12V- 4A
"	9.7565.004 F C	10	3	" " " " 12V-12A
155	9.7565.004 F C	10	6	rondella/washer x avv.el./el.start 12V- 4A
156	9.1760.042 F C	10	6	bullone/bolt x " " 12V- 4A
157	9.1765.003 F IC	10	4	bullone/bolt M 7 X 1 X 24 std.
"	9.1765.009 FV C	10	4	x avv.manov./hand-crank st.
159	90.8460.083 D	10	1	spina/taper pin
160	500.4570.012 DV C	10	1	guarnizione/gasket
161	283.4055.003 F C		1	fune avviamento/rope starting
162+113+114+115+163+				FILTRD COMBUSTIBILE COMPLETO
164+165+166+167=				FUEL FILTER ASS.Y
"	=500.3730.028 FV C		1	
162+	500.2175.032 FV C		1	cartuccia comb./fuel filter element
163+	273.4490.017 FV C	10	1	guarnizione/gasket
164+	500.4431.040 FV C	10	1	guarnizione/gasket
165+	9.1760.076 N A		1	bullone/bolt
166+	9.1202.052 FVAC	10	1	anello OR/rubber oil seal
167+165+166=				COPERCHIO FILTRD
"	=500.2605.024 F IC		1	FILTER COVER ASS.Y
168	9.4670.058 FV C	10	1	guarnizione/copper gasket
169+239+240=				CUMANDU
"	=500.2516.013 F C		1	CONTROL ASS.Y
170+	9.3200.015 FV C	10	1	dado/nut
171	9.9790.039 FV C	10	4	vite/screw M 6 X 1 X 12

FIG. NO.	MATRICOLA P.NO	Q.ta Q.ty	NOTE REMARKS	GR. 6 - 1.5302.145 Pag. 05
	172+175+176+178+179+ 239+240+243+244+571= =500.2515.087 F C	1	COMANDO A DISTANZA COMPLETO REMOTE CONTROL ASS.Y	
	173+ 9.7626.054 S AC 10	2	rondella/washer	
	175+ 9.3240.008 FV 10	1	dado/nut	
	176+ 500.5202.014 F C 10	1	leva/lever	
	177+118+119+120+121+ 122+123+170+173+175+ 176+178+179+180= =500.2691.020 F C	1	COMANDO A MANO COMPLETO HAND CONTROL ASS.Y	
	178+ 500.5660.044 SV C 10	1	molla/spring	
	179+ 500.5202.060 S C 10	1	leva/lever	
	180+ 500.6371.033 D C	1	piastra/plate	
	181 9.3240.008 FV 10	1	dado/nut	
	182 9.1760.029 D C 10	1	bullone/bolt M 6 X 1 X 30	
	183+ 9.3240.008 FV 10	1	dado/nut	
	184+ 9.7565.004 F C 10	1	rondella/washer	
	185+ 9.3240.058 DV C 10	1	dado/nut	
	186+185= =540.8576.016 DV C 10	1	SUPPLEMENTO DI COPPIA/EXTRA FUEL DEVICE valido fino... per regolatore giri a sfere ed attuato per regolatore giri a masse up to eng.S.no... for ball speed governor and again valid for weight speed governor valido da... per regolatore giri a sfere from eng.S.no... for ball speed governor	
	=500.8576.025 DVAC	1		
	192 500.5095.099 S C 10	1	lamiera/panel	
	193 9.9790.037 FV C 10	2	vite/screw M 6 X 1 X 8	
	199+135+136+205+207+ 208+209+210= =540.4330.039 S C	1	GRUPPO BILANC.COMPLETO ROCKER ARM ASS.Y	
	200+ 9.1200.034 FV C 10	1	anello OR/rubber oil seal	
	201+ 500.1110.071 F C	1	albero decompressione/decompression shaft	
	202+ 9.8430.023 S C 10	1	spina/locating pin	
	203+ 500.5680.046 S C 10	1	molla/spring	
	204+200+201+202+203+ 206+634= =502.3349.017 FV C	1	DECOMPRESSIONE COMPLETA DECOMPRESSION ASS.Y	
	204+ 500.5270.078 F C	1	leva/lever	
	205+ 540.6045.038 DV C	1	perno/rocker arm shaft	
	206+ 9.8430.009 S 10	1	spina/locating pin	
	207+ 500.9850.048 S C 10	1	vite/screw	
	208+ 9.3240.008 FV 10	2	dado/nut	
	209+ 500.9850.052 D C 10	1	vite/screw	
	210+		vedi/see fig.No. 199+...	
	211 500.5271.022 E	1	valido fino.../up to eng.s.No...	
	" 500.5271.054 F IC	1	valido da.../from eng.s.No...	
	212 9.3240.018 FV 10	2	dado/nut	
	213 9.7555.007 FV C 10	2	rondella/washer	
	214 503.6275.069 D	1	piastra/plate 6LD325/C-400/C	
	215 9.1200.001 FV C 10	2	anello OR/rubber oil seal	
	216 500.5271.022 E	1	valido fino.../up to eng.s.No...	
	" 500.5271.054 F IC	1	valido da.../from eng.s.No...	
	217 500.7550.006 S C 10	1	rondella/washer	
	218 500.6140.080 S C 10	1	perno/pin	
	219 500.6400.045 SV C 10	1	piattello/cup	
	220 520.6578.041 FV C	1	pompante/plunger 6LD325-325/C std	
	" 540.6578.027 FV C	1	pompante/plunger 6LD360-400-400/C std	
	" 540.6578.032 FV C	1	" " " " Bosch	
	221+151+222+223= =520.6500.318 FV C	1	PISTONE COMPLETO (TASSATIVO 3 CAVE) PISTON ASS.Y (MUST BE 3 GROOVES) std. x 6LD325-325/C	
	=520.6500.319 F CR	1	+0,50 " " "	
	=520.6500.320 F CR	1	+1,00 " " "	
	=530.6500.238 FV C	1	std. x 6LD360	
	=530.6500.239 F CR	1	+0,50 " " "	
	=530.6500.240 F CR	1	+1,00 " " "	
	=540.6500.150 FV C	1	std. x 6LD400-400/C	
	=540.6500.151 F CR	1	+0,50 " " "	
	=540.6500.152 F CR	1	+1,00 " " "	
	222+ 500.8480.023 S C	1	spinotto/gudgeon pin x 6LD325-325/C-360	
	" 395.8480.030 D C	1	" " " x 6LD400-400/C	
	223+ 9.1240.017 FV C 10	2	anello seeger/snap ring	

FIG. NO.	MATRICOLA P.NO	Q.ta Q.ty	NOTE REMARKS	GR. 6 - 1.5302.145 Pag.06
224	9.7565.004 F C 10	5	rondella/washer	
225	9.1760.042 F C 10	5	x avv.el./el.st. 12V- 4A-M 6 X 1 X 18	
"	9.9730.015 F C 10	5	x " " 12V-12A-M 6 X 1 X 30	
226	540.5066.053 S C	1	lamiera/airtight plate	
227	520.6370.154 D C	1	piastra 6LD325 std. & 325/C std. shroud pl.	
"	500.6370.175 N	1	piastra/shroud pl. 6LD325 inson./denoised	
"	540.6370.118 S C	1	" " 6LD360-400-400/C std.	
"	540.6370.166 N	1	per/for 6LD360-400-400/C insonor./denoised	
"	540.6370.119 S C	1	per avv.elettr.anche su motori insonorizz. for elect.start. also on denoised engines	
228	530.4570.010 FV C	1	guarnizione/gasket std.	
"	530.4570.011 FV C 10	1	per avviamento elettr./for electr.starting	
229	500.2568.086 S C	1	convogl./shroud 6LD325 std.	
"	500.2569.167 N	1	" " inson./denoised	
"	540.2569.058 S C	1	" " 6LD360-400 std.	
"	540.2569.154 D C	1	" " " inson./denoised	
"	503.2568.087 D	1	" " 6LD325/C std.	
"	543.2569.061 D C	1	" " 6LD400/C std.	
"	543.2569.169 N	1	" " inson./denoised	
"	530.2568.078 F AC	1	per avviamento elettr./for electr.starting	
"	540.2569.156 N	1	per avviam.elettr. su motori insonorizzati for electric starting on denoised engines	
230	540.6370.128 S C	1	per avv.manovella/for senza impianto luce per hand-crank st.with/without light.syst.	
232	500.2568.098 S AC	1	per avviam.manovella/for hand-c.starting	
233	9.1901.032 FVIC 10	1	bullone raccordo/connection bolt	
234	9.1901.030 FVIC 10	1	bullone raccordo/connection bolt	
235	5000.9374.036 S C	1	tubo da pompa alim.a filtro comb.sul mot pipe from pump to filter on eng.(mm 360)	
"	5000.9375.011 N	1	tubo da pompa al.a filtro comb.staccato pipe from pump to remote filter (mm 1035)	
236	9.4670.059 FVIC 10	1	guarnizione/copper gasket	
237	9.4670.059 FVIC 10	1	guarnizione/copper gasket	
238	5000.9375.240 S AC	1	tubo da filtro comb.a pompa al. (mm 368) pipe from fuel filter to feed pump	
239+	70.9180.011 S C 10	2	terminale/cable-end	
240+	9.3240.009 FV C 10	2	dado/nut	
241	9.4670.059 FVIC 10	1	guarnizione/copper gasket	
242	9.1901.030 FVIC 10	1	bullone raccordo/connection bolt	
243+	9.9790.023 F C 10	1	vite/screw M 5 X 0.8 X 7	
244+	90.6000.031 S C 10	1	pastiglia/nut	
245+	9.3203.047 FV C 10	2	dado/nut	
247+		vedi/see fig.No. 254+...	
248+	500.6371.045 N A 10	1	piastra/piate	
249+	540.5801.198 SVAC 10	1	molla/spring	
250+	500.5680.043 S C 10	1	molla/spring	
251+		vedi/see fig.No. 254+...	
252+	9.8420.002 S C 10	1	spina/locating pin	
253	9.9730.010 S 10	2	vite/screw M 6 X 1 X 16	
254+183+184+247+250+			SUPPORTO LEVA REGOLATORE	
251+252+255+256+257+			CONTROL LEVER SUPPORT	
=540.8785.076 D C (B)		1	fino a... per regol.giri a sfere ed attuale per regolatore giri a masse up to eng.S.no... for ball speed governor and again valid for weight speed governor	
254+183+184+247+250+			SUPPORTO LEVA REGOLATORE	
251+252+255+256+257+			CONTROL LEVER SUPPORT	
=500.8785.075 S AC		1	valido da... per regolatore giri a sfere e from eng.S.no... for ball speed governor	
255+	9.1200.087 FV C 10	1	anello OR/rubber oil seal	
256+		vedi/see fig.No. 254+...	
257+		vedi/see fig.No. 254+...	
258	540.5655.081 SV8C 10	1	molla/spring std. & gr.elettrog./gen.sets	
"	500.5655.038 SVAC 10	1	" " " " " " " "	
259+	710.2800.049 N 10	1	copiglia/cotter pin	
266+	9.7555.004 FV C 10	1	rondella/washer	
267+	9.1760.007 S 10	1	bullone/bolt	
268+	500.2135.072 FVBC 10	1	cappello/cap	
269+	500.6410.036 F C 10	2	piattello/retainer with half-collets	
270+	500.5755.045 FV C 10	2	molla/spring	
271+	540.6850.108 SV C	2	prigion.lato distribuzione/gear side stud	

FIG. NO.	MATRICOLA P.NO	Q.ta Q.ty	NOTE REMARKS	GR. 6 - 1.5302.145 Pag.07
272+	520.4730.206 N	10	1	0,55 x 6LD325-325/C guarn.testa/head gasket
"	520.4730.159 N	10	1	0,60 " " " "
"	520.4730.207 N	10	1	0,65 " " " "
"	520.4730.160 SV C	10	1	0,70 " " " "
"	520.4730.208 N	10	1	0,75 " " " "
"	520.4730.161 N	10	1	0,80 " " " "
"	520.4730.209 N	10	1	0,85 " " " "
"	520.4730.162 N	10	1	0,90 " " " "
"	520.4730.210 N	10	1	0,95 " " " "
"	520.4730.163 N	10	1	1,00 " " " "
"	530.4730.171 SV C	10	1	0,50 x 6LD360 " " " "
"	530.4730.180 SV C	10	1	0,55 " " " "
"	530.4730.145 SV C	10	1	0,60 " " " "
"	530.4730.181 SV C	10	1	0,65 " " " "
"	530.4730.146 SV C	10	1	0,70 " " " "
"	530.4730.182 SV C	10	1	0,75 " " " "
"	530.4730.147 SV C	10	1	0,80 " " " "
"	530.4730.183 SV C	10	1	0,85 " " " "
"	530.4730.148 SV C	10	1	0,90 " " " "
"	530.4730.184 SV C	10	1	0,95 " " " "
"	540.4730.130 SV C	10	1	0,50 x 6LD400-400/C " " " "
"	540.4730.175 SV C	10	1	0,55 " " " "
"	540.4730.122 SV C	10	1	0,60 " " " "
"	540.4730.176 SV C	10	1	0,65 " " " "
"	540.4730.123 SV C	10	1	0,70 " " " "
"	540.4730.177 SV C	10	1	0,75 " " " "
"	540.4730.124 SV C	10	1	0,80 " " " "
"	540.4730.178 SV C	10	1	0,85 " " " "
"	540.4730.133 DV C	10	1	0,90 " " " "
"	540.4730.179 DV C	10	1	0,95 " " " "
273	500.4740.018 FV C	10	1	guarnizione/upper gasket
274	500.4740.025 FV C	10	1	guarnizione/lower gasket
275	500.9520.046 FVIC	10	1	tubo protez./guard tube
276	500.1410.016 FV C	10	2	asta punteria/push rod
277	9.1240.004 FV C	10	1	anello seeger/snap ring
278	9.2280.050 S	10	1	x 6LD325/C-400/C cilindr./cylindr. P.T.D.
279	500.7550.006 S C	10	1	rondella/washer
280	503.1011.049 S AC	10	1	Ext.4 SAE 6LD360/C-400/C da.../from eng...
281+	9.7626.048 S C	10	2	rondella/washer
282+	9.1770.083 FV C	10	2	bullone/bolt M 8 X 1,25 X 50
283+281+282=	500.1526.030 F AC	10	1	BIELLA COMPLETA CONNECTING ROD
284	360.1640.066 FVIC	10	1	bronz.biella/large end bushing std.
"	360.1640.067 F ICR	10	1	" " " -0,25
"	360.1640.068 F ICR	10	1	" " " -0,50
285	5000.6607.015 N I	10	1	per avviam.el./for el.starting 12 V-4 A
286	9.9730.010 S	10	1	vite/screw M 6 X 1 X 16
287+	500.4700.094 FVBC	50	1	0,30 std. & x avv.manov./handle starting
"	500.4701.003 FVBC	50	1	0,20 " " " "
"	500.4701.015 S BC	50	1	0,10 " " " "
"	500.4701.017 FVBC	50	1	0,40 " " " "
288	500.8675.135 F AC	10	1	std. & avv.el./el.start.12 V-4 A & anche avv.manov.con/senza impianto luce also handle st.with/without light.system
"	500.8675.150 S AC	10	1	x avviam.el./el.starting 12 V-12 A
289	9.1210.092 FV C	10	1	anello tenuta/seal ring 6LD325-360-400
"	9.1213.001 FV C	10	1	" " " 6LD325/C-400/C
290	540.5066.054 S C	10	1	lamiera/airtight plate
291	9.9790.037 FV C	10	2	vite/screw M 6 X 1 X 8
292	9.7565.007 F C	10	2	rondella/washer
293	540.6480.041 D	10	1	pignone per avv.man.con/senza imp.luce handle st.with/without ligh.system pinion
294	5000.6275.093 N	10	1	per avviamento elett./for el.starting
296	9.4670.016 FV C	10	1	guarnizione/copper gasket
297	9.4670.016 FV C	10	1	guarnizione/copper gasket
301	500.6585.032 FV C	10	1	pompa alimentazione/feed pump
303	500.7200.048 SV C	10	1	puntalino/drive rod
304+	255.6700.012 S C	10	1	portina/pan
305+	560.4580.047 FVIC	50	1	guarnizione/gasket 1,00
"	560.4580.049 FV C	10	1	" " " 0,50
"	560.4580.050 FV C	10	1	" " " 0,80
306+	9.8780.007 S	10	2	prigioniero/stud M 8 X 20 (32)
308	9.3203.047 D	10	1	dado/nut
309	10	1	
310+311+312=	500.4936.064 S IC	10	1	INGRANAGGIO REGOLATORE/SPEED GOVERN GEAR per gruppi elettrog./for generating sets
311+	9.8400.073 N	10	2	spina/taper pin
312+	10	2	vedi/see fig.No. 310+...

FIG. NO.	MATRICOLA P.NO	Q.ta Q.ty	NOTE REMARKS	GR. 6 - 1.5302.145 Pag.08
315	500.4896.002 S	1	gruppo campana regol./governor bell	
316	9.9810.002 D C 10	2	vite/screw	
317	9.8420.023 S C 10	1	spina/locating pin	
318+	9.8245.010 F B 10	6	sfera/ball (1/2" - mm 12,7)	
"	9.8245.009 F AC 10	6	" " (7/16" - mm 11,1)	
319+	500.6141.016 DVAC	1	perno leva pompa olio/oil pump pin lever	
320+	9.2200.013 S C 10	1	chiavetta/key std.	
"	9.2280.061 D C 10	1	per gruppi elettrog./for generating sets	
321	9.1585.029 N 10	1	per gruppi elettrog./for generating sets	
322	9.1240.077 FV C 10	1	per gruppi elettrog./for generating sets	
323+248+249+319+320+			POMPA OLIO/OIL PUMP valido da.../from...	
324=			per regol.giri sfere/for ball speed gover.	
=520.6605.064 SVAC	1	x 6LD 325-360-400		
=523.6605.065 DV C	1	x 6LD 325/C-400/C		
324+	500.3855.007 D C	1	flangia/flange 6LD325-360-400	
"	503.3855.009 D C	1	" " 6LD325/C-400/C	
325+	520.9652.040 FVACR10	1	valvola aspirazione/inlet valve	
326+	500.3430.070 FVAC 10	2	fondello/cup	
327+	520.9685.051 FVACR10	1	valvola scarico/exhaust valve	
329+	540.6850.106 SV C	2	prigion.lato volano/flywheel side stud	
330	9.2280.047 F 10	1	chiavetta/key	
331	500.1011.004 S BC	1	fino a.../up to eng.s.No... x 6LD400	
"	500.1011.052 F BC	1	da...e fino.../from...to... x 6LD325-360-400	
"	500.1011.151 F AC	1	da.../from eng.s.No... x 6LD325-360-400	
332	503.1011.053 D AC	1	albero camme/camshaft 6LD325/C-400/C	
333	9.9765.076 D BC 10	1	vite/screw 6LD325-360-400	
334	9.1585.004 S C	1	boccola/bushing 6LD325/C-400/C	
335+	9.2280.047 F B 10	1	per albero/for shaft std. conic.	
"	9.2280.052 D C 10	1	" " EXT. a 3	
336+	500.9000.069 S 10	2	tappo/expansion plug	
337+(335)+336+338=			ALBERO A GOMITO/CRANKSHAFT	
=500.1050.115 F IC	1	x 6LD325-360-400 std.conic. (mm 300)		
337+336+338=			x 6LD325-360-400 EXT. 4 (mm 383,4)	
=500.1050.126 S IC	1			
338+	9.2280.048 FV C 10	1	chiavetta lato volano/flywheel side key	
339	500.1257.008 FVBC 10	1	anello reggispira/thrust washer	
340	500.1611.012 FVIC	1	bronz.l.volano/flywheel side bear. std.	
"	500.1611.013 F ICR	1	" " -0,50	
"	500.1611.014 F ICR	1	" " -1,00	
342	9.7505.007 F C 10	4	rondella/washer	
343	9.1770.002 FV 10	4	bullone/bolt std. M 8 X 1,25 X 16	
"	9.1770.005 F 10	4	x avv.el./el.starting M 8 X 1,25 X 22	
"	9.1770.056 S C 10	4	x avv.manov./handle starting	
344	9.9790.037 FV C 10	6	bullone/bolt M 6 X 1 X 8	
345	9.1760.032 S C 10	2	vite/screw M 6 X 1 X 14	
346	9.7625.092 D C 10	2	rondella/washer	
347	9.7555.004 FV C 10	2	rondella/washer	
348	9.3240.008 FV 10	2	dado/nut	
365	9.3203.060 FV C 10	1	dado/nut	
366				
367+318+368+371=			REGOLATORE A SFERE/SPEED GOVERNOR ASS.Y	
=540.7362.126 S BC	1	valido fino.../up to eng.S.no...		
=500.7362.109 S AC	1	valido da.../from eng.S.no...		
367+	540.4936.047 S BC	1	ingranaggio/gearwheel	
"	500.4936.020 F AC	1	" " " "	
368+	540.2086.081 D B	1	campana regolatore/governor bell	
"	500.2085.072 S A	1	" " " "	
369	9.9730.016 DV C 10	4	vite/screw M 8 X 1 X 35	
370	9.7565.004 F C 10	4	rondella/washer	
371+	500.1160.011 DV C 10	1	anello/circlip	
372	9.9732.063 S AC 10	9	vite/screw M 8 X 1,25 X 35	
373	9.9730.028 F 10	1	vite/screw M 8 X 1,25 X 30	
374	530.1611.018 FVIC	1	bronz.l.distrib./gear side bearing std.	
"	530.1611.019 F ICR	1	" " -0,50	
"	530.1611.020 F ICR	1	" " -1,00	
375	9.1240.077 FV C 10	1	per gruppi elettrog./for generating sets	
376	9.1585.029 N 10	1	per gruppi elettrog./for generating sets	
377+	276.8460.055 D C 10	2	spina/taper pin	
378	9.1770.039 S C 10	1	bullone/bolt M 8 X 1,25 X 28	
379	9.7625.060 S C 10	1	rondella/washer	
380	500.1257.008 FV C 10	1	anello reggispira/thrust washer	
381+	9.2280.050 S 10	1	chiavetta per albero/key for shaft EXT. 4	
382+335+336+338=			x 6LD325-360-400 (motopompe/pumping units)	
=500.1050.118 S IC	1	EXT. A 3 (mm 391)		

FIG. NO.	MATRICOLA P.NO	Q.ta Q.ty	NOTE REMARKS	GR. 6 - 1:5302.145 Pag.09
382+336+338+381=	=500.1050.117 S IC	1	EXT.4 SAE J 609 A (mm 365.5)	
382+336+338=	=500.1050.121 S IC	1	EXT.9 SAE J 609 A (mm 365.5)	
	=500.1050.127 S IC	1	EXT.9 SAE J 609 A (mm 366,2)	
			filetto/thread mm 26,2	
383	9.1760.001 FV	10	2	bullone/bolt M 6 X 1 X 10
384	9.7565.004 F C	10	2	rondella/washer
385	9.1585.058 S		2	boccola/bushing
387	9.8430.019 S	10	1	spina/locating pin
389	5000.8965.031 D		1	tappo/plug
389	9.1202.016 FV C	10	1	anello/ring
390	270.5801.027 D A		1	molla/spring
391	500.7980.045 S A		1	scodellino/cup
392	9.1240.041 S	10	1	anello seeger/snap ring
393	270.5455.006 S		1	manovella/handle 6LD325-360-400
"	715.5455.014 S C		1	" 6LD325/C-400/C
394	9.7565.007 F C	10	1	rondella/washer
395			
396	5000.8506.007 N		1	squadretta/angle bracket
401	9040.2615.021 F C		1	coperchio/cover
402	9040.6612.063 S AC		1	spia olio/oil warning
403	9040.6612.064 S AC		1	spia batteria/battery warning
404	9040.5175.119 F AC	10	2	lampadina/lamp
412+	9.1213.056 FVIC	10	1	anello tenuta/seal ring 6LD325-360-400
413+	9.3030.028 FV C	10	1	cuscinetto/ball bearing std.
"	9.3030.046 S		1	per portina con giochi assiali ridotti for cover case with reduced rad.clearance
414+	500.4601.002 FV C	10	1	guarnizione/gasket 0,30
"	500.4601.020 FV C	10	1	" 0,20
415+	9.6780.076 FV C	10	5	prigioniero/stud M 8 X 18 (34)
"	500.5000.011 DVBC		1	lappo per raccordo plug preset for connect
"	500.9060.012 DVAC		1	
417	9.4670.062 DVBC	10	1	guarnizione/copper gasket
"	9.4670.058 FVAC	10	1	
418	9.1760.001 D BC	10	1	bullone/bolt M 6 X 1 X 10
"	9.1770.001 D AC	10	1	" M 8 X 1,25 X 12
419+336+338=	=503.1050.116 S IC	1	ALBERO A GOMITO/CRANKSHAFT	
			std. x 6LD325/C-400/C (mm 264)	
420+597=	=9040.6745.031 FVAC	1	PRESSOSTATO COMPLETO	
			PRESSURE OIL SWITCH	
420	2760.5040.098 SV C		1	interruttore press.olio/switch by press.oil
421	276.4670.014 SV C	10	1	per pressostato/pressure oil gasket
"	9.4670.061 FVIC	10	1	per interrott./switch by press.oil gasket
422	292.5840.065 F		1	motorino avviam./start engine 12 V
423	540.2690.145 S C		1	coperchio/cover
424	283.4970.012 D A		1	ingranaggio/gearwheel
425	500.7885.026 S I		1	scatola/case
426	9.7565.007 F C	10	3	rondella/washer
427	9.1770.005 F	10	3	bullone/bolt M 8 X 1,25 X 22
428	292.8335.073 D	10	1	spessore/spacer
429	530.3790.040 S A		1	flangia/flange
430	9.3203.047 FV C	10	1	dado/nut
433	5300.8546.028 F AC		1	staffa/brace (per mot./for st.eng.Bosch)
434			
435	9.7625.012 FV C	10	1	rondella/washer
436	9.1770.004 F C	10	1	bullone/bolt M 8 X 1,25 X 20
437	9.7565.004 F C	10	2	rondella/washer
438	9.1760.003 F	10	2	bullone/bolt M 6 X 1 X 12
442	2000.5040.004 Sv C		1	interruttore/switch key
"	2760.5041.020 FV C		1	" Bosch
451	5000.8760.044 N		1	supporto/support
452	9.7625.012 FV C	10	2	rondella/washer
453	9.3240.018 FV	10	2	dado/nut
454	9.7565.007 F C	10	2	rondella/washer
455	9.1770.006 S	10	2	bullone/bolt M 8 X 1,25 X 25
456+503=	=2830.3730.036 FV C	1	FILTRO COMBUSTIBILE ESTERNO	
			EXTERNAL FUEL FILTER	
457	9.4670.016 FV C	10	2	guarnizione/copper gasket
458+412+413=	=500.6645.202 F IC	1	PORTINA/CASE COVER 6LD325-360-400	
	=5000.6645.203 D I	1	std. per giochi ass.rid./for red.radial clear.	

FIG. NO.	MATRICOLA P.NO	Q.ta Q.ty	NOTE REMARKS	GR. 6 - 1.5302.145 Pag. 10
459+507+508=	=500.6647.045 S IC =5000.6647.046 S IC	1 1	PORTINA DI FONDO/OIL PAN std. x 6LD325-325/C-360 std. x 6LD400-400/C & profonda/deep x 6LD325-325/C-360	
460+	500.4601.003 FVBC 50	1	guarnizione/gasket	
461+	500.4776.016 S C 10	1	guarnizione/gasket	
462	500.1745.001 S C	1	bulbo/oil pipe std. x 6LD325-325/C-360	
"	5000.1745.002 D C	1	" std. x 6LD400-400/C & x port.prof.su/deep pan on 6LD325-325/C-360	
463	500.2175.019 FV C	1	cartuccia olio/oil filter element	
464	500.9680.013 SV C	1	valvola pressione/pressure oil valve	
465	500.9070.012 S C	1	tappo valvola/valve cap	
466	9.4670.021 FV C 10	1	guarnizione/copper gasket	
467	500.5755.049 FV C 10	1	molla/spring	
468	500.5725.032 FV C 10	1	molla/spring	
469	9.1200.016 FV C 10	1	anello OR/rubber oil seal	
470	500.9060.008 FV C	1	tappo filtro/filter cap	
471	500.6427.035 F C	2	piede/engine mount std. x 6LD325-325/C-360	
472	5000.7330.075 S BC	1	per pressostato/for pressure switch	
"	9040.7330.019 D A	1	"	
"	5000.7330.138 D C	1	per interruttore/for switch by press.oil	
473	9.4670.062 DVBC 10	2	guarnizione/copper gasket	
"	9.4670.058 FVAC 10	2	"	
474	9.1901.058 FVIC 10	1	bullone raccordo/connection bolt M 6	
"	9.1901.048 SVAC 10	1	" M 8	
477	9.3240.066 FV C 10	2	dado/nut	
478	9.7565.011 F C 10	2	rondella/washer	
479	9.6800.026 F 10	2	prigioniero/stud M 10 X 35 (50)	
480	276.2145.014 FVAC	1	cappuccio/rubber cap	
481+	9.1210.030 FV C 10	1	anello tenuta/seal ring 6LD325/C-400/C	
482+413+481=	=500.6646.076 D C	1	PORTINA/CASE COVER 6LD325/C-400/C std.	
483	9.3000.040 S C	1	cuscinetto/ball bearing 6LD325/C-400/C	
484	9.1770.009 D C 10	1	bullone/bolt M 8 X 1,25 X 35	
485	5300.8546.031 S AC	1	per mot.avv./for start.eng. Femsa/Marelli	
503+	2830.2175.045 FVAC	1	cartuccia combustib./fuel filter element	
504	5000.9375.020 D C	1	tubo da filtro comb.staccato a pompa in. pipe from remote filter to pump (mm 1036)	
"	5000.9375.079 N	1	tubo da filtro comb.sul mot.a pompa in. pipe from f.filter on engine to inj.pump	
505	9.4670.016 FV C 10	2	guarnizione/copper gasket	
506	9.1901.032 FVIC 10	2	bullone raccordo/connection bolt	
507+	9.4670.013 FV C 10	1	guarnizione/copper gasket	
508+	9.8965.032 S AC 10	1	tappo/oil drain plug	
509	9.6780.005 S 10	8	prigioniero/stud M 8 X 18 (30)	
510	9.7565.007 F C 10	8	rondella/washer	
511	9.3240.016 FV C 10	8	dado/nut	
512	5000.8506.009 N	1	squadretta/angle bracket	
513	5000.8506.008 N	1	angle bracket	
514	276.6740.088 FVAC 10	1	presa regol./inlet volt.reg. Saprisa	
"	276.6740.089 SVAC 10	1	" Ducati	
"	276.0740.030 SVAC 10	1	x reg.Ducati con spia c.b./with c.b.light	
515+	9.3030.028 FV C 10	1	cuscinetto/ball bearing std.	
"	9.3030.046 S	1	per portina con giochi assiali ridotti for cover case with reduced rad.clearance	
516+412+515=	=5000.6646.097 E =5000.6645.214 D IC =5000.6645.216 N	1 1 1	x 6LD325-360-400 FLANG. A & B SAE J 609 A std. con giochi ass.ridotti/with red.clearance	
517+	500.4500.091 FV C 10	2	guarnizione/gasket	
518				
519	9.3240.095 FV C 10	2	dado/nut	
521	9.9790.037 FV C 10	3	vite/screw	
534				
535	9.1770.111 F C 10	10	bullone/bolt M 8	
536	5000.6428.065 S C	2	piede/eng.mount std. 6LD400-400/C & x port.prof.su/deep pan on 6LD325-325/C-360	
537	5000.6428.036 D C	1	piede lato scarico/exhaust side mount	
"	5000.6428.037 D C	1	piede lato aspirazione/inlet side mount	
539	9.9730.023 N	2	vite/screw M 8 X 1,25 X 10	
540	9040.7362.066 FVIC	1	regol.tensione/voltage regul.12 V-12 A con spia c.b./with c.b.light	
541	9.1770.004 F C 10	2	bullone/bolt M 8 X 1,25 X 20	
542	9.7565.007 F C 10	2	rondella/washer	
543	9.3240.018 FV 10	2	dado/nut	
544	530.3902.034 S BC	1	flangia per avv.el./flange for el.start.	

FIG. NO.	MATRICOLA P.NO	Q.ta Q.ty	NOTE REMARKS	GR. 6 - 1.5302.145 Pag.11
545	500.5462.089 F IC	1	marmitta/muffler std. (avv.fune/rope st.)	
"	5000.5462.094 S C	1	marmitta pred.per prot.(mot.con avv.fune)	
546	5000.6927.048 D C	1	murrler suitable for guard (rope start.)	
547	530.3700.132 FV C	1	protezione/guard	
548	530.2175.050 FV C	1	filtro a secco/dry air cleaner std.	
552	9.3203.047 FV C 10	5	cartuccia filtro aria/air el.element	
553+		dado/nut	
554	540.5801.087 SVBC 10	1	Vedi/see fig.No. 254+...	
"	540.5801.196 D BC 10	1	molla/spring std.	
555+	540.6140.135 DVBC	1	" " special mini-voiture	
"	5400.6140.136 D C	1	perno/pin std.	
			per gruppi elettrog./for generating sets	
556+259+266+267= =540.5200.176 S C 10		1	LEVA COMANDO POMPA INIEZIONE INJECTION PUMP CONTROL LEVER	
557+320+324+555= =540.6605.049 SVBC		1	POMPA OLIO/LUB OIL PUMP	
=5400.6605.050 S C		1	x 6LD325-360-400 std.	
=543.6605.052 D BC		1	x 6LD325-360-400 gr.elettrog./gen.sets	
			x 6LD325/C-400/C std.	
559	520.2380.177 FV C	1	cilindro/cylinder 6LD325-325/C	
"	530.2380.172 FV C	1	" " 6LD360	
"	540.2380.132 FV C	1	" " 6LD400-400/C	
560+245+246+271+304+ 305+306+329+377+415= =520.1510.216 D C		1	BASAMENTO COMPLETO CRANKCASE	
=540.1510.171 S C		1	std. x 6LD325-325/C	
=5400.1510.181 D C		1	std. x 6LD360-400-400/C	
=5400.1510.260 N		1	x el magnet comando/control stop	
			x disp. -REN- /preset for -REN- device	
561	9.9732.047 D C 10	1	vite/screw M 12 X 1,5 X 20	
563+	9.9730.000 D AC 10	1	vite M 8 X 1 X 10	
564+	9.7565.004 F AC 10	1	rondella/washer	
565	9.1760.001 FV 10	4	bullone/bolt M 6 X 1 X 10	
566	9.9790.037 FV C 10	1	vite/screw	
567	260.5390.006 S C 10	1	manicotto/rubber sheathing	
569	9.9731.030 D 10	2	vite/screw M 8 X 1,25 X 12	
570+	500.4500.091 FV C 10	1	guarnizione/gasket	
571+	9.7626.054 S AC 10	1	rondella/washer	
572	9.3203.045 N 10	2	dado/nut	
574	5000.6010.066 N	1	pattino/guard pad	
575	720.3527.004 F 10	4	distanziale/spacer	
576	9.7625.012 FV C 10	4	rondella/washer	
577	9.1770.007 F C 10	4	bullone/bolt	
578	5000.1213.143 N 10	1	anello/ring	
579	5000.6495.029 N	1	pistoncino/plunger	
580	9.1202.013 FV C 10	1	anello/ring	
581	5000.5625.007 N 10	1	molla/spring	
582	5000.3902.074 N	1	flangia f.olio est./ext.oil filt.flange	
583	276.4670.014 SV C 10	1	guarnizione/copper gasket	
584	9.8965.003 FV C 10	1	tappo/plug	
585	9.4670.058 FV C 10	1	guarnizione/copper gasket	
586	9.9732.074 S C 10	2	vite/screw M 8 X 1,25 X 20	
587	9.4670.039 FV C 10	1	guarnizione/copper gasket	
588	9.8965.021 S C 10	1	tappo/plug	
589	904.2175.040 FV C	1	cartuccia olio/extern.oil filter element	
590	9.4670.061 FVIC 10	4	guarnizione/copper gasket	
591	5600.5953.048 N 10	4	nippolo/needle	
592	8320.9485.029 S C	2	tubo olio/oil pipe (mm 544)	
"	5000.9485.081 S C	2	" " (mm 270)	
593	276.7330.066 N	1	raccordo/connection	
594	5000.9220.028 N	1	testina/oil filter head	
595	5000.3902.120 N	1	flangia f.olio stacc./remote oil flange	
597+	3600.6491.013 FVAC	1	pipetta/pipe elbow	
598	273.7300.057 FVBC 10	1	raccordo/connection	
599	9.3630.008 F C 10	1	fascetta/clamp	
607	9040.2900.069 F C	1	cruscotto/dashboard	
608	9040.2900.070 F C	1	cruscotto/dashboard	
609	2760.2750.111 F C	1	coperchio/switch key cover	
610	2760.5450.009 FV C	1	manometro olio/pressure gauge	
614	530.5460.188 F AC	1	marm.per mot.con avv.el./el.st.muffler	
"	5300.5460.216 S C	1	marmitta insonorizz./denoised muffler	
"	5000.5460.228 N	1	marmitta insonor.predisp.per protezione denoised muffler preset for muffler guard	
628	360.2900.064 S C	1	cruscotto/dashboard	
629+	500.5496.113 SVAC	1	massa filtrante/filtering elem. diam.=124	
630+	276.4115.048 F C 10	2	gancio/hook	
631+		vedi/see fig. No. 9+...	
632	500.7301.006 DV C 10	1	raccordo/connection	
633	260.4650.037 DV C 10	1	guarnizione/gasket	
634+	276.2135.056 N 10	1	cappelotto/cap	

MATERIALE DI RETTIFICA
GRINDING WORKSHOP PARTS LIST
MATRIEL POUR RECTIFIEUR

Gr. 6 - 1.5302.145
Pag.13

MOTORI-ENGINES-MOTEURS GR. 6 Cilindro staccato/Detacheable cylinder

FIG. NO.	MATRICOLA P. NO	Q.ta Q.ty	NOTE REMARKS
80+	500.4845.166 FVICR10	1	guida v.asp./inlet v.guide std.
"	500.4845.167 FCICR10	1	" " " +0,50
82+	500.4845.168 FVACR10	1	guida v.scar./exhaust v.guide std.
"	500.4845.169 FVACR10	1	" " " +0,50
141+	283.8000.036 FVACR10	1	sede v.aspiraz./inlet v.seat
142+	283.8000.037 FVACR10	1	sede v.scarico/exhaust v.seat
151+	520.8211.079 F CR10	1	+0,50 x 6LD325-325/C serie segm./ring set
"	520.8211.080 F CR10	1	+1,00 " " " "
"	530.8211.046 F CR10	1	+0,50 x 6LD360 " " " "
"	530.8211.047 F CR10	1	+1,00 " " " "
"	540.8211.017 F CR10	1	+0,50 x 6LD400-400/C " " " "
"	540.8211.018 F CR10	1	+1,00 " " " "
221+151+222+223=			PISTONE COMPLETO (TASSATIVO 3 CAVE) PISTON ASS.Y (MUST BE 3 GROOVES)
	=520.6500.319 F CR	1	+0,50 x 6LD325-325/C
	=520.6500.320 F CR	1	+1,00 " " " "
	=530.6500.239 F CR	1	+0,50 x 6LD360 " " " "
	=530.6500.240 F CR	1	+1,00 " " " "
	=540.6500.151 F CR	1	+0,50 x 6LD400-400/C
	=540.6500.152 F CR	1	+1,00 " " " "
284	360.1640.067 F ICR	1	bronz.biella/large end bushing -0,25
"	360.1640.068 F ICR	1	" " " -0,50
325+	520.9652.040 FVACR10	1	valvola aspirazione/inlet valve
327+	520.9685.051 FVACR10	1	valvola scarico/exhaust valve
340	500.1611.013 F ICR	1	bronz.l.volano/flywheel side bear. -0,50
"	500.1611.014 F ICR	1	" " " -1,00
374	530.1611.019 F ICR	1	bronz.l.distrib./gear side bearing 0,50
"	530.1611.020 F ICR	1	" " " -1,00
43+71+79+147+272+ 287+305+414+460+461+ 517+570=			SERIE GUARNIZIONI GASKET SET
	=520.8180.092 FV CR	1	x 6LD325-325/C
	=530.8180.082 FV CR	1	x 6LD360
	=540.8180.063 SV CR	1	x 6LD400-400/C