

TAVOLA RICAMBI
TABLEAU PIECES DETACHEES
SPARE PARTS TABLE
ERSATZTEILTAFEL
TABLA DE REPUESTOS
TÁBUA PEÇAS DE TROCA

SERIE 1. IM
250 - 251 - 252
300 - 301 - 302
350 - 351 - 352
353 - 354 - 355
356 - 357 - 358

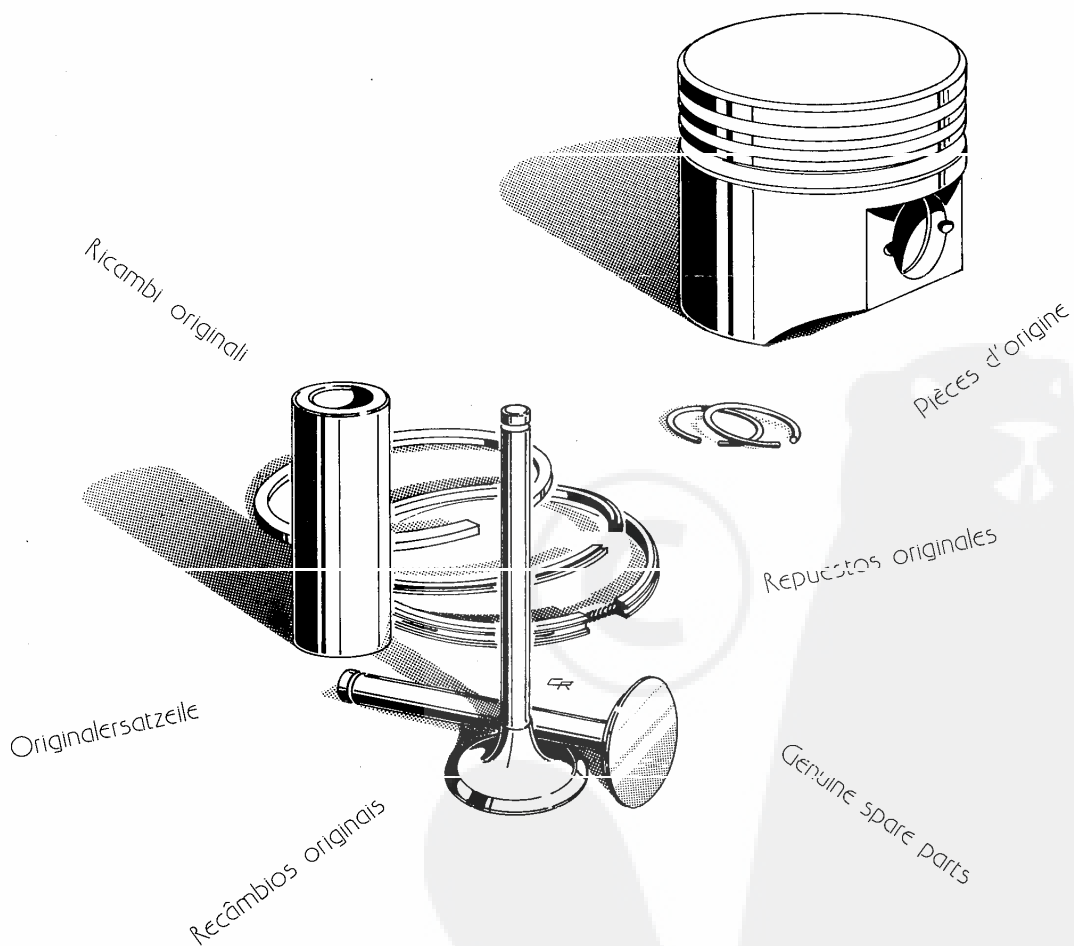

 **intermotor**

BY  **LOMBARDINI**

**RICAMBI PER MOTORE STANDARD.
PER APPLICAZIONI SPECIALI
CONSULTARE IL CATALOGO PRESSO I
CENTRI ASSISTENZA E RICAMBI.**

**PIECES POUR DES MOTEURS
STANDARD.
POUR LES ADAPTATIONS CONSULTER
LE CATALOGUE AUPRES DES AGENTS
SERVICE.**

**SPARE PARTS FOR STANDARD
ENGINE.
FOR SPECIAL APPLICATIONS SEE
MASTER CATALOG AT SERVICE
CENTERS.**

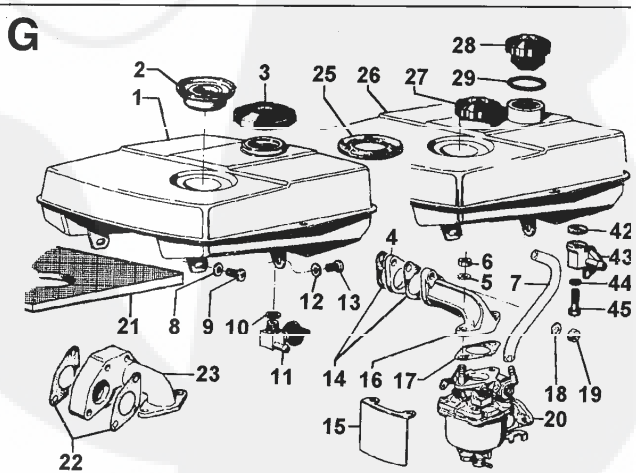
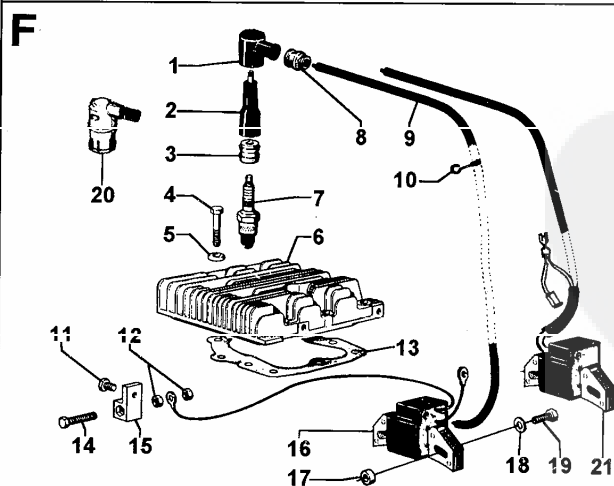
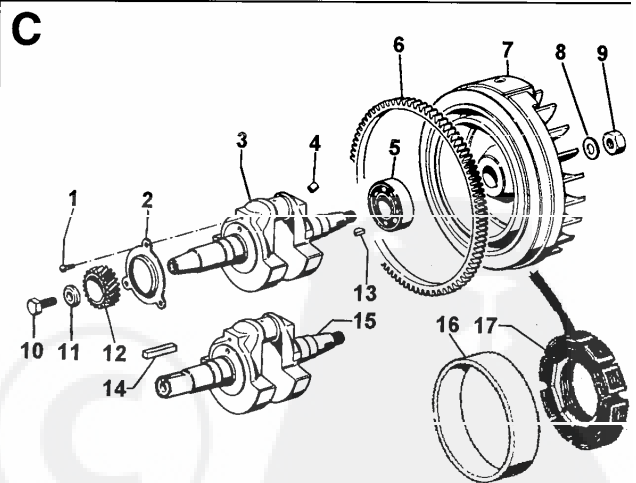
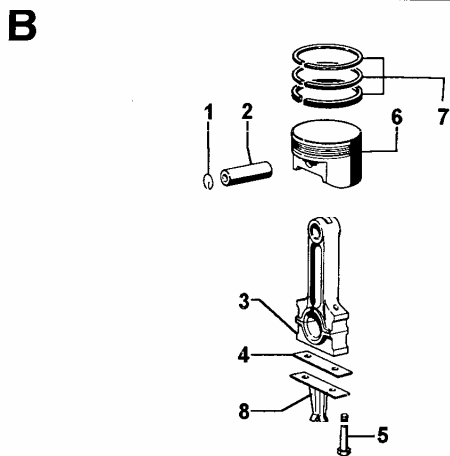
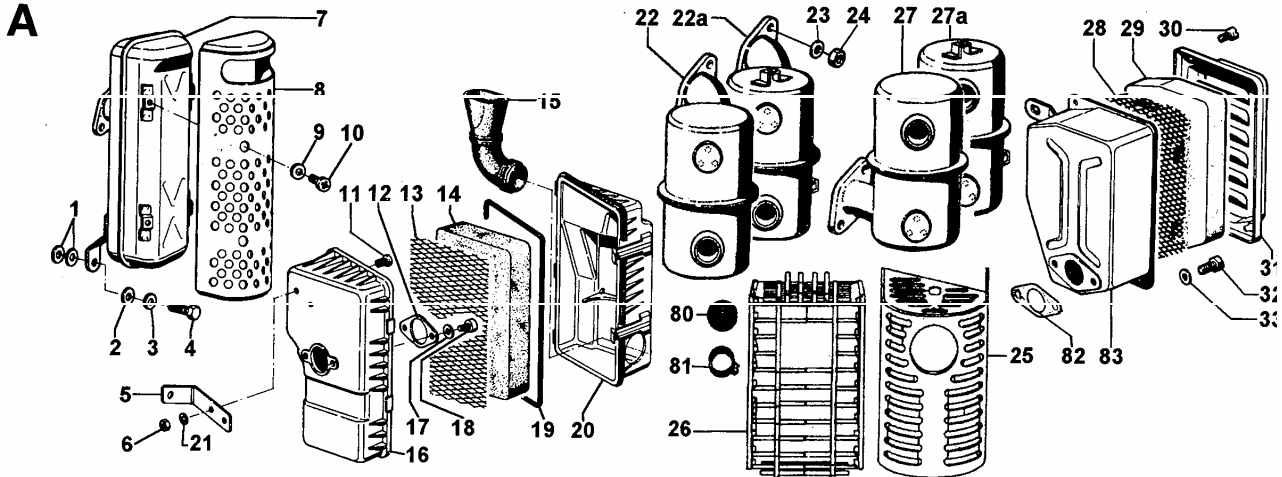

ERSATZTEILE FÜR STANDARD-MOTOREN.
FÜR SONDERANFERTIGUNGEN SIEHE ERSATZTEILKATALOG BEI SERVICE WERKSTÄTTEN.

REPUESTOS PARA MOTORES STANDARD.
PARA APLICACIONES VEASE CATALOGO EN LAS ESTACIONES SERVICE.

PEÇAS DE TROCA PARA MOTOR STANDARD.
PARA APLICAÇÕES ESPECIAIS CONSULTAR O CATÁLOGO NOS CENTROS DE ASSISTÊNCIA E PEÇAS DE TROCA.

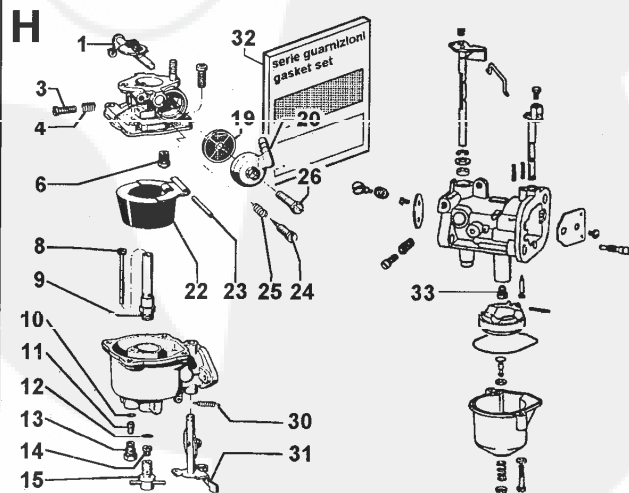
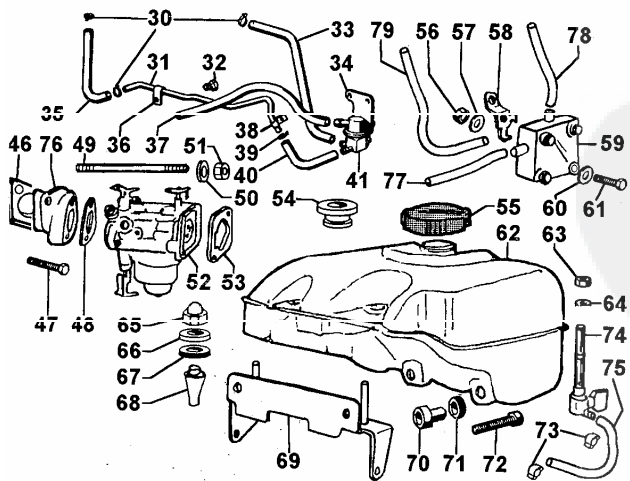
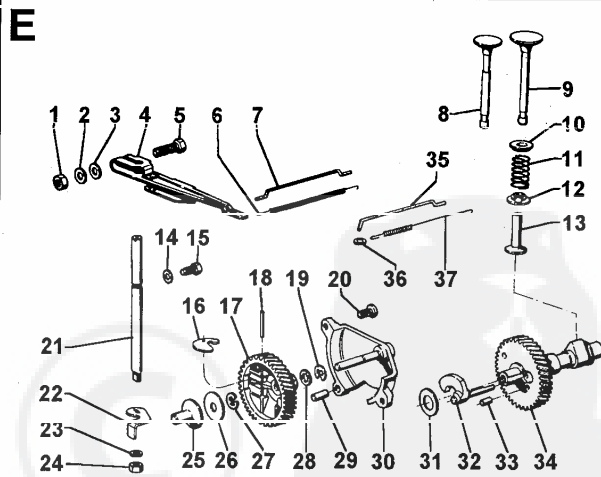
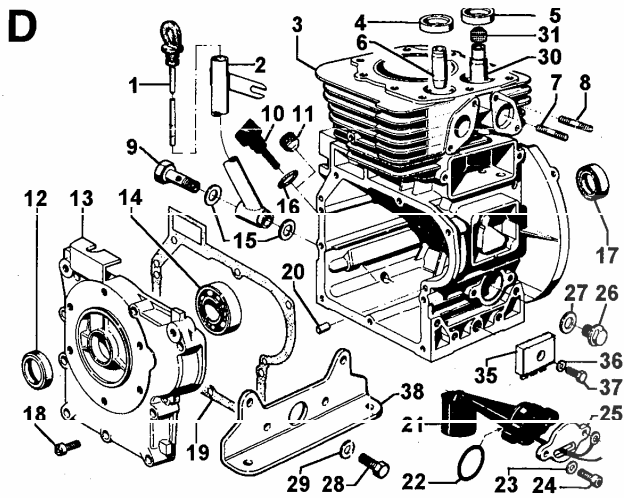
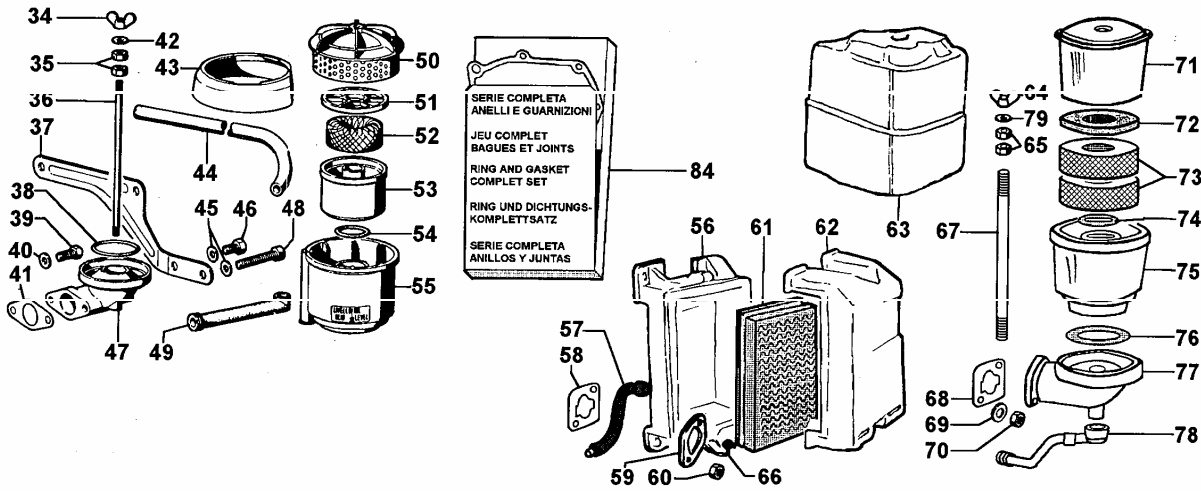
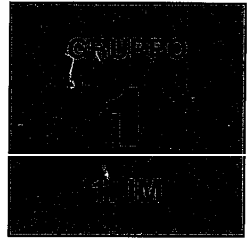

SERVICE

Per assistenza e ricambi rivolgersi a sezioni di servizio autorizzate intermotor. Il tel. si libretto servizio e su pagina finale.
 Pour toute exigence de service après-vente et pièces de rechange s'adresser aux Stations de service Inter-moteur. N. de téléphone indiqué sur brochure relative au service après-vente et annuaire catalogue.
 For spare parts and after sale assistance contact authorized intermotor service centers. Tel. No. appears on service booklet and telephone directory.
 Für Service und Ersatzteile bitte an autorisierte Werkstätte wenden. Telefon-Nummer finden Sie beim Service-Richtlinien und Telefonverzeichnis.
 Para asistencia y repuestos dirigirse a las estaciones de servicio autorizadas intermotor. N.º Tel. en libramos de servicio y en páginas amarillas.
 Para assistência e trocas dirigirse às estações de serviço autorizadas intermotor. Número telefónico sobre a caderneta de serviço e sobre as páginas amarelas.

**ORDINARIAMENT
 COMMANDES PIÈCES
 PART ORDERS
 BESTELBESTELLUNGEN
 PRODUCTOS DE REPUESTOS
 PEDIDOS DE RECAMBIO**

**TIPO MOTORE - MATRICOLA
 TYPE DE MOTEUR - MATRICULE
 ENGINE TYPE - SERIAL NUMBER
 MOTORTYP - MOTORENUMMER
 TIPO DEL MOTOR - NUMERO DEL MOTOR
 TIPO DE MOTOR - NUMERO DO MOTOR**

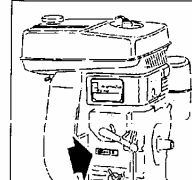
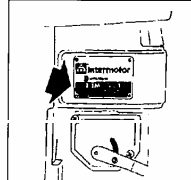
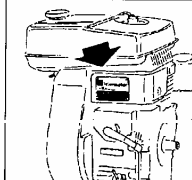

**TIPO DELLA MACCHINA
 TYPE DE MACHINE
 EQUIPMENT TYPE
 MASCHINTENTYPE
 MODELO DE LA MAQUINA
 TIPO DA MAQUINA**

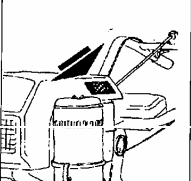
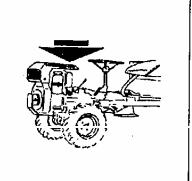

**MATRICOLA DEL RICAMBIO
 REFERENCE DE LA PIÈCE
 SPARE PART NUMBER
 BESTELNUMBER DES TEILES
 REFERENCIA DEL REPUESTO
 REFERÊNCIA DO RECÂMPIO**

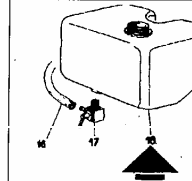
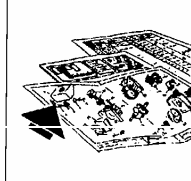

1	100-1000-000	2	100-1000-000
10	100-1000-000	11	100-1000-000
12	100-1000-000	13	100-1000-000
14	100-1000-000	15	100-1000-000
16	100-1000-000	17	100-1000-000
18	100-1000-000	19	100-1000-000
20	100-1000-000	21	100-1000-000
22	100-1000-000	23	100-1000-000
24	100-1000-000	25	100-1000-000
26	100-1000-000	27	100-1000-000
28	100-1000-000	29	100-1000-000
30	100-1000-000	31	100-1000-000
32	100-1000-000	33	100-1000-000
34	100-1000-000	35	100-1000-000

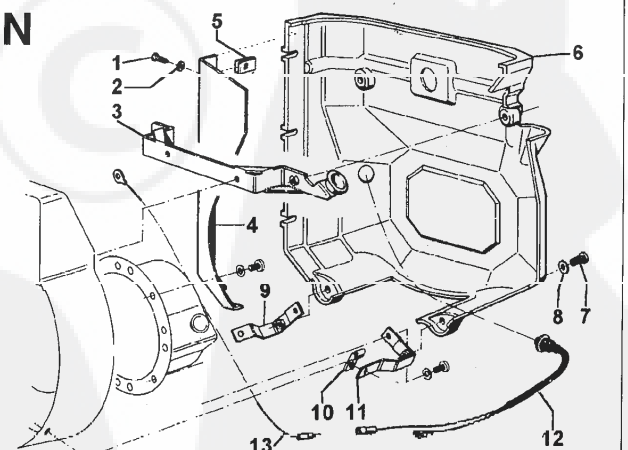
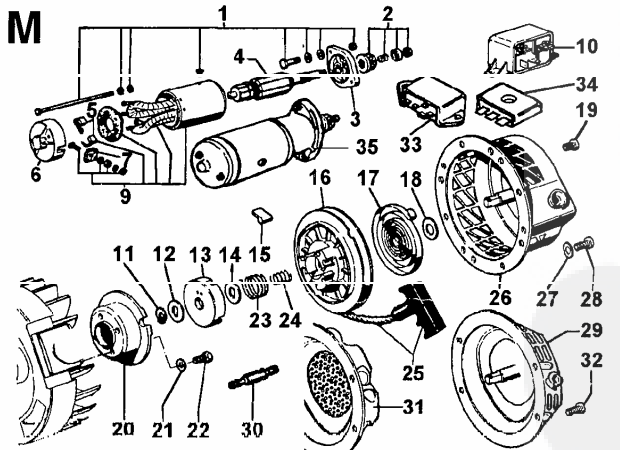
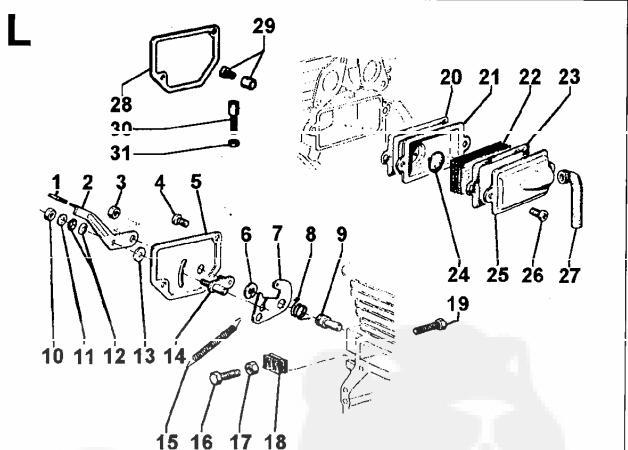
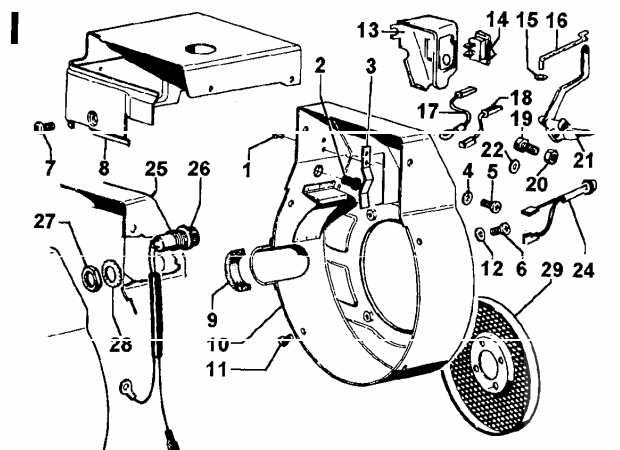



Intermotor
 S.p.A.
 02100 Rieti Italy - Casella Postale 107 - Tel. 0746/22.00.41



LOMBARDINI Company
 Tel. 0746/25951000 - Telefax 0746/22.00.00

Subject to attention
 Printed in Italy

INT - COMPONENTI
 DICOMERICA

CONTRIBUTO
 125/02731

MODELLO
 15/1924

DATA EMISSIONE
 01/916

REVISIONE 00

DATA VISTO
 01/06/98





intermotor

Gr. 1IM

vedi TAVOLA RIC./see SPARE P.TABLE/voir TABLEAU P.DETACH. 1.5302.485

Giugno/June/Juin 1996

MOTORI/ENGINES/MOTEURS Gr. 1IM
1IM 250-251-252 1IM 300-301-302 1IM 350-351-352 1IM 359-359 "CEE"
standard & restyling

Vedi/See/Voir

Libretto Uso e Man./Use-Maint.booklet/Livret Emploi-Entret. 1.5302.481
Libretto Service/Service directory/Reseau S.A.V. 1.7968.004

A - valido dal motore vedi Circolare Tecnica
from engine S.No see Service Letter
à partir du moteur voir Circulaire Technique

B - valido fino al motore vedi Circolare Tecnica
up to engine s.No. see Service Letter
jusqu'au moteur voir Circulaire Technique

I - intercambiabile vedi Circolare Tecnica
interchangeable see Service Letter
interchangeable voir Circulaire Technique

E - ad esaurimento/exhausting part/piece en epuisement.
npd non più disponibile/no longer available/non plus dispnibile
ctvar vedi circolare variazione matricole di particolari intercambiabili
see variation of interchangeable parts numbers
voir variation matricules des pièces interchangeables

Descrizioni non impegnative/Subject to modifications/Modifications réservées
TECO/ATL/Assistenza Tecnica Lombardini/Giugno 1996

Riquadro Drawing Dessin	A	ASPIRAZIONE E SCARICO INTAKE AND EXHAUST ADMISSION ET ECHAPPEMENT	Riquadro Drawing Dessin	G	CIRCUITO COMBUSTIBILE FUEL SYSTEM CIRCUIT CARBURANT
Riquadro Drawing Dessin	B	BIELLA E PISTONE CONNECT.ROD/PISTON SET BIELLE ET PISTON	Riquadro Drawing Dessin	H	CARBURATORE CARBURATOR CARBURATEUR
Riquadro Drawing Dessin	C	ALBERO A GOMITO E VOLANO CRANKSHAFT AND FLYWHEEL VILEBREQUIN ET VOLANT	Riquadro Drawing Dessin	I	LAMIERATI COOLING PANELS TOILES DE REFROIDISSEMENT
Riquadro Drawing Dessin	D	BASAMENTO/PORTINA/PIEDI CRANKCASE/COVER/MOUNTS CARTER/COTE DIST./PIEDS	Riquadro Drawing Dessin	L	COMANDI CONTROLS COMMANDES
Riquadro Drawing Dessin	E	DISTRIBUZIONE/REG.GIRI TIMING/SPEED GOVERNOR DISTRIBUTION/REG.VITESSE	Riquadro Drawing Dessin	M	AVVIAMENTO STARTING DEMARREUR
Riquadro Drawing Dessin	F	TESTA E ACCENSIONE CYL. HEAD AND IGNITION CULASSE ET ALLUMAGE	Riquadro Drawing Dessin	N	INSONORIZZAZIONE SOUNDPROFING INSONORISATION

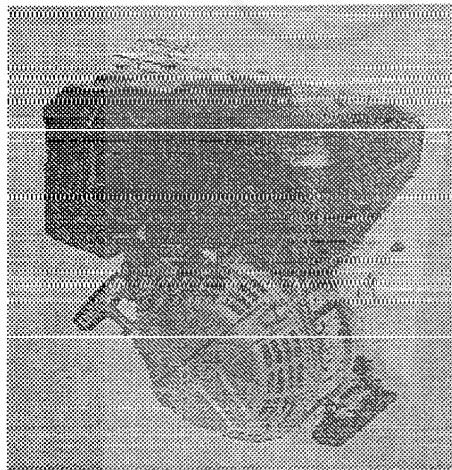

 intermotor Motori serie 1 IM 1 IM series engines				vedi Tav. Ric. see Parts Table 1.5302.485		RESTYLING										vedi circolare tecnica see service letter	intercambiabilità interchangeability
Pos.	Matricola/Part No.	Note/Remarks		1 M 250-251	1 M 252	1 M 300-301	1 M 302	1 M 350-351	1 M 352	1 M 359	1 M 359 "CEE"	1 M 250	1 M 300	1 M 350	1 M 359		
A 1	7626.064	9	d.8,25x15	2	2	2	2	2	2	2	2	2	2	2	2		
A 2	7625.010	9	d.8x15	1	1	1	1	1	1	1	1	1	1	1	1		
A 3	7565.007	9	d.8,2x14	1	1	1	1	1	1	1	1	1	1	1	1		
A 4	1770.004	9	M 8x20	1	1	1	1	1	1	1	1	1	1	1	1		
A 5	8506.086	1580		1	1	1	1	1	1	1	1	1	1	1	1		
A 6	3240.004	9	M 5x0,8	2	2	2	2	2	2	2	2	2	2	2	2		
A 7	ex 5460.322	-> npd		x	x	x	x	x	x	x	x	x	x	x	x	751	si
	ex 5460.331	-> npd		x	x	x	x	x	x	x	x	x	x	x	x	751	si
	ex 5460.341	-> E		x	x	x	x	x	x	x	x	x	x	x	x		
	ex 5460.374	-> npd		x	x	x	x	x	x	x	x	x	x	x	x	ctvar	si
	-> 5460.460	158	I insonor./denoised	1	1	1	1	1	1	1	1	1	1	1	1		
A 8	ex 6927.196	-> npd		x	x	x	x	x	x	x	x	x	x	x	x	ctvar	si
	-> 6927.367	1470	I	1	1	1	1	1	1	1	1	1	1	1	1		
A 9	7625.007	9	d.6x12	4	4	4	4	4	4	4	4	4	4	4	4		
A 10	9790.037	9	M 6x8	4	4	4	4	4	4	4	4	4	4	4	4		
A 11	9790.028	9	M 5x10	2	2	2	2	2	2	2	2	2	2	2	2		
A 12	3790.062	1470		1	1	1	1	1	1	1	1	1	1	1	1		
A 13	ex 3930.091	-> npd	vedi/see Pos.A 16	x	x	x	x	x	x	x	x	x	x	x	x		
A 14	5496.165	1580		1	1	1	1	1	1	1	1	1	1	1	1		
A 15	9410.078	1580		1	1	1	1	1	1	1	1	1	1	1	1		
A 16	=3700.323	1690	insonor./denoised	1	1	1	1	1	1	1	1	1	1	1	1		
	Pos.12-13-14-15-16-19-20.																
A 17	7625.008	9	d.6,4x12	2	2	2	2	2	2	2	2	2	2	2	2		
A 18	9730.012	9	M 6x20	2	2	2	2	2	2	2	2	2	2	2	2		
A 19	4775.495	169		1	1	1	1	1	1	1	1	1	1	1	1		
A 20		vedi/see Pos.A 16	x	x	x	x	x	x	x	x	x	x	x	x		
A 21	7625.005	9	d.5x10	2	2	2	2	2	2	2	2	2	2	2	2		
A 22	ex 5462.070	-> npd		x	x	x	x	x	x	x	x	x	x	x	x	22003	si
	-> 5460.400	147	I standard	1	1	1	1	1	1	1	1	1	1	1	1		
A 22a	ex 5460.355	-> npd		x	x	x	x	x	x	x	x	x	x	x	x	22003	no
	ex 5460.101	-> npd		x	x	x	x	x	x	x	x	x	x	x	x	22003	no
	-> 5460.410	1470	A	1	1	1	1	1	1	1	1	1	1	1	1		
A 23	7565.004	9	d.6,1x11	2	2	2	2	2	2	2	2	2	2	2	2		
A 24	3240.009	9	M 6	2	2	2	2	2	2	2	2	2	2	2	2		
A 25	ex 6927.058	-> E		x	x	x	x	x	x	x	x	x	x	x	x	22003	no
	-> 6927.294	147	A standard	1	1	1	1	1	1	1	1	1	1	1	1		
"	ex 6927.057	-> E		x	x	x	x	x	x	x	x	x	x	x	x	22003	no
	6927.296	147	A MTC/motorcultivat	1	1	1	1	1	1	1	1	1	1	1	1		
A 26	ex 6927.243	-> E		x	x	x	x	x	x	x	x	x	x	x	x	22003	no
	-> 6927.231	1470	A standard	1	1	1	1	1	1	1	1	1	1	1	1		
"	ex 6927.244	-> E		x	x	x	x	x	x	x	x	x	x	x	x	22003	no
	-> 6927.292	1470	MTC/motorcultivat	1	1	1	1	1	1	1	1	1	1	1	1		
A 27	ex 5462.077	-> npd		x	x	x	x	x	x	x	x	x	x	x	x	22003	si
	ex 5460.394	-> npd		x	x	x	x	x	x	x	x	x	x	x	x	ctvar	si
	-> 5460.486	1470	I MTC/motorcultivat	1	1	1	1	1	1	1	1	1	1	1	1		
A 27a	ex 5460.100	-> npd		x	x	x	x	x	x	x	x	x	x	x	x	22003	no
	ex 5460.356	-> E		x	x	x	x	x	x	x	x	x	x	x	x	22003	no
	-> 5460.408	1470	A MTC/motorcultivat	1	1	1	1	1	1	1	1	1	1	1	1		
A 28		vedi/see Pos.A 83	x	x	x	x	x	x	x	x	x	x	x	x		
A 29	5496.062	147		1	1	1	1	1	1	1	1	1	1	1	1		
A 30	9760.011	9	M 3,5x13	2	2	2	2	2	2	2	2	2	2	2	2		
A 31		vedi/see Pos.A 83	x	x	x	x	x	x	x	x	x	x	x	x		
A 32	1760.003	9	M 6x12	2	2	2	2	2	2	2	2	2	2	2	2		
A 33	7565.004	9	d.6,1x11	2	2	2	2	2	2	2	2	2	2	2	2		
A 34	3200.015	9		-	-	-	-	-	-	-	-	-	-	-	-		
A 35	3240.004	9	M 5x0,8	-	-	-	-	-	-	-	-	-	-	-	-		
A 36	9245.055	150		-	-	-	-	-	-	-	-	-	-	-	-		
A 37	8490.076	155		-	-	-	-	-	-	-	-	-	-	-	-		
A 38	1200.070	9	OR 154	-	-	-	-	-	-	-	-	-	-	-	-		
A 39	9731.085	9	M 6x25	-	-	-	-	-	-	-	-	-	-	-	-		
A 40	7565.004	9	d.6,1x11	-	-	-	-	-	-	-	-	-	-	-	-		

 intermotor Motori serie 1 IM 1 IM series engines			vedi Tav. Ric. see Parts Table 1.5302.485		RESTYLING								vedi circolare tecnica see service letter	intercambiabilità interchangeability
Pos.	Matricola/Part No.	Note/Remarks	TIM 250-251	TIM 252	TIM 300-301	TIM 302	TIM 350-351	TIM 352	TIM 359	TIM 359 "CEE"	TIM 250	TIM 300	TIM 350	TIM 359
A 41	4490.072 1580						1	1	1					
A 42	7625.005 9	d.5x10					1	1	1					
A 43	6927.081 1470						1	1	1					
A 44	9375.098 147						1	1	1					
A 45	7565.004 9	d.6,1x11					2	2	2					
A 46	1760.003 9	M 6x12					1	1	1					
A 47	vedi/see Pos.A 55					x	x	x					
A 48	1760.061 9	M 6x6					1	1	1					
A 49	9400.031 150						1	1	1					
A 50	vedi/see Pos.A 55					x	x	x					
A 51	vedi/see Pos.A 55					x	x	x					
A 52	2175.024 150						1	1	1					
A 53	vedi/see Pos.A 55					x	x	x					
A 54	1200.085 9	OR 3131					1	1	1					
A 55	=3703.004 155 Pos.34-35-36-37-38-41-42-45-46-47- 48-49-50-51-52-53-54-55.						1	1	1					
A 55	=3700.207 1470 Pos.34-35-36-38-42-43-47-50-51-52- 53-54-55.						1	1	1					
A 56	vedi/see Pos.A 62									x	x	x	x
A 57										1	1	1	1
A 58	4501.124 158										1	1	1	1
A 59	3790.081 158										1	1	1	1
A 60	3203.050 9	M 6x1									2	2	2	2
A 61	2175.150 183										1	1	1	1
A 62	=3700.377 158 " =3700.378 158 Pos.56-61-62-66.	standard ribassato/downward									1	1	1	1
A 63	=3700.372 147 Pos.63-64-65-67-71-72-73-74-75-76- 77-79.	a bagno d'olio oil bath airclean.									1	1	1	1
A 64	3200.015 9										1	1	1	1
A 65	3240.004 9	M 5x0,8									2	2	2	2
A 66	4115.069 158										2	2	2	2
A 67	9245.055 150										1	1	1	1
A 68	4501.124 158										1	1	1	1
A 69	7565.007 9	d.8,2x14									2	2	2	2
A 70	3240.008 9	M 6x1									2	2	2	2
A 71	vedi/see Pos.A 63									x	x	x	x
A 72	5496.229 147										1	1	1	1
A 73	2175.024 150										2	2	2	2
A 74	1200.085 9	OR 3131									1	1	1	1
A 75	vedi/see Pos.A 63									x	x	x	x
A 76	1200.071 9	OR 156									1	1	1	1
A 77	vedi/see Pos.A 63									x	x	x	x
A 78	9580.077 158										1	1	1	1
A 79	7625.005 9	d.5x10									1	1	1	1
A 80	3360.039 1470	A	1	1	1	1	1	1	1	1	1	1	1	1
A 81	3630.156 9	A	1	1	1	1	1	1	1	1	1	1	1	1
A 82	4490.072 1580		1	1	1	1	1	1	1	1	-	-	-	-
A 83	=3700.277 1580 Pos.28-29-30-31-83.	insonor./denoised	1	1	1	1	1	1	1	1	-	-	-	-

intermotor
Motore serie 1 IM
1 IM series engines

vedi Tav. Ric.
 see Parts Table
 1.5302.485

Pos.	Matricola/Part No.	Note/Remarks	RESTYLING								vedi circolare tecnica see service letter	Intercambiabilità Interchangeability	
			1IM 250-251	1IM 252	1IM 300-301	1IM 302	1IM 350-351	1IM 352	1IM 359	1IM 359 "CEE"			
A 84	8180.186 147		1	1	-	-	-	-	1	-	-	-	-
"	8180.187 155		-	-	1	-	-	-	-	1	-	-	-
"	8180.188 158		-	-	-	1	1	-	-	-	1	-	-
"	ex 8180.172 -> npd		-	-	-	-	-	-	-	-	-	-	-
"	-> 8180.193 158	I	-	-	-	-	x	x	-	-	-	x	-
A 85	6927.403 1580	A	-	-	-	-	-	1	1	-	1	-	-
A 86	6370.140 147	A	-	-	-	-	-	-	-	-	2	2	-
A 87	2193.099 147	A	-	-	-	-	-	-	-	-	2	2	-
B 1	1261.070 147		2	2	2	2	2	2	2	2	2	2	2
B 2	8480.002 147		1	1	1	1	1	1	1	1	1	1	1
B 3	=1526.026 147	std	1	1	1	1	1	1	1	1	1	1	1
"	=1526.027 147	-0,25	1	1	1	1	1	1	1	1	1	1	1
"	=1526.028 147	-0,50	1	1	1	1	1	1	1	1	1	1	1
	Pos. 3- 4- 5.												
B 4	6330.055 90		1	1	1	1	1	1	1	1	1	1	1
B 5	1760.030 9	M 6x45	2	2	2	2	2	2	2	2	2	2	2
B 6	=6502.080 147	std	1	1	-	-	-	-	1	-	-	-	-
"	=6502.092 147	+0,50	1	1	-	-	-	-	1	-	-	-	-
"	=6502.083 147	+1,00	1	1	-	-	-	-	1	-	-	-	-
"	=6502.015 150	std	-	-	1	1	-	-	-	1	-	-	-
"	=6502.016 150	+0,50	-	-	1	1	-	-	-	1	-	-	-
"	=6502.017 150	+1,00	-	-	1	1	-	-	-	1	-	-	-
"	=6502.081 158	std	-	-	1	1	1	1	-	-	1	1	-
"	=6502.084 158	+0,50	-	-	1	1	1	1	-	-	1	1	-
"	=6502.085 158	+1,00	-	-	1	1	1	1	-	-	1	1	-
	Pos. 1- 2- 6- 7.												
B 7	8210.096 147	std	1	1	-	-	-	-	1	-	-	-	-
"	8210.097 147	+0,50	1	1	-	-	-	-	1	-	-	-	-
"	8210.098 147	+1,00	1	1	-	-	-	-	1	-	-	-	-
"	8210.077 150	std	-	-	1	1	-	-	-	1	-	-	-
"	8210.078 150	+0,50	-	-	1	1	-	-	-	1	-	-	-
"	8210.079 150	+1,00	-	-	1	1	-	-	-	1	-	-	-
"	ex 8210.099 ->	B	-	-	1	1	-	-	-	1	-	-	-
"	-> 8211.197 169	A std	-	-	x	x	x	x	-	-	22001	no	-
"	ex 8211.001 ->	B	-	-	1	1	1	1	-	1	22001	no	-
"	-> 8211.198 169	A +0,50	-	-	1	1	1	1	-	1	22001	no	-
"	ex 8211.002 ->	B	-	-	x	x	x	x	-	-	22001	no	-
"	-> 8211.199 169	A +1,00	-	-	1	1	1	1	-	1	22001	no	-
B 8	5168.055 1580		1	1	1	1	1	1	1	1	1	1	1
C 1	7481.024 9		3	3	3	3	3	3	3	3	3	3	3
C 2	2194.014 147		1	1	1	1	1	1	1	1	1	1	1
C 3	ex 1052.029 ->		x	x	x	x	x	x	-	-	762	no	-
"	->=1050.729 147	(A) standard	1	1	1	1	1	1	1	1	762	no	-
"	ex 1052.090 ->	B	-	-	x	x	x	x	-	-	762	no	-
"	->=1050.739 1470	A Ext 4	-	-	1	1	1	1	-	1	762	no	-
"	ex 1052.088 ->	B	-	-	x	x	x	x	-	-	762	no	-
"	-1050.735 1470	A Ext 8A	1	1	1	1	1	1	1	1	762	no	-
	Pos. 1- 2- 3- 4-12-13.												
C 4	9000.027 90		1	1	1	1	1	1	1	1	1	1	1
C 5	3001.070 9	* 6206 C3	1	1	1	1	1	1	1	1	1	1	1

 Motori serie 1 IM 1 IM series engines			vedi Tav. Ric. see Parts Table 1.5302.485		RESTYLING										vedi circolare tecnica see service letter	intercambiabilità interchangeability
Pos.	Matricola/Part No.	Note/Remarks	1IM 250-251	1IM 252	1IM 300-301	1IM 302	1IM 350-351	1IM 352	1IM 359	1IM 359 "CEE"	1IM 250	1IM 300	1IM 350	1IM 359		
C 6	2816.034 1470		1	1	1	1	1	1	1	1	1	1	1	1		
C 7	ex 9880.219 ->	E	x	x	x	x	x	x	x	x	x	x	x	x	757	si
"	-> 9880.537 147	I standard	1	1	1	1	1	1	1	1	1	1	1	1	757	no
"	ex 9880.218 -> npd		x	x	x	x	x	x	x	x	x	x	x	x		
"	-> 9880.538 1470	A per altern.luce for lighting alt.	1	1	1	1	1	1	1	1	1	1	1	1	757	no
"	ex 9884.095 -> npd		x	x	x	x	x	x	x	x	x	x	x	x		
"	->=9880.540 1470	A per avviamento elettrico	1	1	1	1	1	1	1	1	1	1	1	1		
	Pos. 6- 7-16.															
C 8	7530.018 90		1	1	1	1	1	1	1	1	1	1	1	1		
C 9	3260.055 9		1	1	1	1	1	1	1	1	1	1	1	1		
C 10	1770.039 9	M 8x28	1	1	1	1	1	1	1	1	1	1	1	1		
C 11	7625.060 9		1	1	1	1	1	1	1	1	1	1	1	1		
C 12	4936.182 147	B solo per alberi con cava lato p.m. for crankshafts with p.t.o. side keyhole only standard	1	1	1	1	1	1	1	1	1	1	1	1	22006	no
C 13	2280.142 9	standard	1	1	1	1	1	1	1	1	1	1	1	1		
C 14	2280.050 9	6,32 x 6,32 x 60	1	1	1	1	1	1	1	1	1	1	1	1		
"	2280.052 9	6,35x9,52x22,225	1	1	1	1	1	1	1	1	1	1	1	1		
"	2280.066 9	4,76 x 4,76 x 50,8	1	1	1	1	1	1	1	1	1	1	1	1		
C 15	ex 1052.082 >	B	x	x	x	x	x	x	x	x	x	x	x	x	762	no
"	->=1050.732 1470	A Ext 3	1	1	1	1	1	1	1	1	1	1	1	1	762	no
"	ex 1052.082 ->	B	x	x	x	x	x	x	x	x	x	x	x	x		
"	->=1050.733 1470	A Ext 4	1	1	1	1	1	1	1	1	1	1	1	1	762	no
"	ex 1052.086 ->	B	x	x	x	x	x	x	x	x	x	x	x	x		
"	->=1050.731 1470	A Ext A3	1	1	1	1	1	1	1	1	1	1	1	1		
	Pos. 2- 3- 4-12-13-15.															
C 16	7750.075 180	A	1	1	1	1	1	1	1	1	1	1	1	1	761	no
C 17	ex 1156.098 ->	B	x	x	x	x	x	x	x	x	x	x	x	x	757	no
"	ex 8565.063 -> npd		x	x	x	x	x	x	x	x	x	x	x	x	764	si
"	-> 8565.072 183	I	1	1	1	1	1	1	1	1	1	1	1	1		
D 1	1400.057 9000		1	1	1	1	1	1	1	1	1	1	1	1		
D 2	9485.217 1470		1	1	1	1	1	1	1	1	1	1	1	1		

 intermotor Motori serie 1 IM 1 IM series engines			vedi Tav. Ric. see Parts Table 1.5302.485		RESTYLING								vedi circolare tecnica see service letter	intercambiabilità interchangeability		
Pos.	matricola/Part no.	Note/Remarks	1IM 250-251	1IM 252	1IM 300-301	1IM 302	1IM 350-351	1IM 352	1IM 359	1IM 359 "CEE"	1IM 250	1IM 300	1IM 350	1IM 359		
D 3	ex 1514.001 ->	npd	x	x											758	si
	ex 1510.436 ->	E	x	x											22005	no
	->=1510.716 147	A (1)	1	1						1						
"	ex 1514.023 ->	E	x	x											758	no
	ex 1510.439 ->	E	x	x											22005	no
	->=1510.722 1470	A (2)	1	1						1						
"	ex 1510.201 ->	E	x	x											758	no
	ex 1510.442 ->	E	x	x											22005	no
	->=1510.726 1470	A (3)	1	1						1						
"	ex 1510.204 ->	E	x	x											758	no
	ex 1510.445 ->	E	x	x											22005	no
	->=1510.730 1470	A (4)	1	1						1						
"	ex 1514.002 ->	npd				x	x								758	si
	ex 1510.437 ->	E				x	x								22005	no
	->=1510.718 155	A (1)			1	1					1					
"	ex 1514.053 ->	npd				x	x								758	no
	ex 1510.440 ->	E				x	x								22005	no
	->=1510.723 1550	A (2)				1	1				1					
"	ex 1510.202 ->	npd				x	x								758	no
	ex 1510.443 ->	E				x	x								22005	no
	->=1510.727 1550	A (3)				1	1				1					
"	ex 1510.205 ->	npd				x	x								758	no
	ex 1510.446 ->	E				x	x								22005	no
	->=1510.731 1550	A (4)				1	1				1					
"	ex 1513.099 ->	npd					x	x				x			758	si
	ex 1510.438 ->	E					x	x				x			22005	no
	->=1510.720 158	A (1)					1	1					1			
"	ex 1514.054 ->	npd					x	x				x			758	no
	ex 1510.441 ->	E					x	x				x			22005	no
	->=1510.724 1580	A (2)					1	1					1			
"	ex 1510.203 ->	E					x	x				x			758	no
	ex 1510.444 ->	E					x	x				x			22005	no
	->=1510.728 1580	A (3)					1	1					1			
"	ex 1510.206 ->	E					x	x				x			758	no
	ex 1510.447 ->	E					x	x				x			22005	no
	->=1510.732 1580	A (4)					1	1					1			
"	ex 1510.490 ->	E						x	x			x			22005	no
	->=1510.721 1690	A (1)						1	1				1			
"	ex 1510.505 ->	E						x	x			x			22005	no
	->=1510.725 1580	A (2)						1	1				1			
"	ex 1510.504 ->	E						x	x			x			22005	no
	->=1510.729 1580	A (3)						1	1				1			
"	ex 1510.506 ->	E						x	x			x			22005	no
	->=1510.733 1580	A (4)						1	1				1			
	Pos. 3- 4- 5- 6-30-L 9.															
		(1) standard														
		(2) per avv.el. for el.start.														
		(3) per spia olio/ for oil alert														
		(4) per avv.el. e spia olio/for el.start. and oil alert														
D 4	ex 8000.169 ->	B	x	x	x	x	x	x	x						22005	no
	-> 8000.121 112	A	1	1	1	1	1	1	1	1	1	1	1	1		
D 5	ex 8000.168 ->	B	x	x	x	x	x	x	x						22005	no
	-> 8000.122 112	A	1	1	1	1	1	1	1	1	1	1	1	1		
D 6	4845.028 90		1	1	1	1	1	1	1	1	1	1	1	1		

 intermotor Motori serie 1 IM 1 IM series engines				vedi Tav. Ric. see Parts Table 1.5302.485		RESTYLING								vedi circolare tecnica see service letter	intercambiabilità interchangeability		
Pos.	Matricola/Part No.	Note/Remarks		1IM 250-251	1IM 252	1IM 300-301	1IM 302	1IM 350-351	1IM 352	1IM 359	1IM 359 "CEE"	1IM 250	1IM 300	1IM 350	1IM 359		
D 7	6760.013	9 B		1	1	1	1	1	1	1	1	1	1	1	1	741	
"	6760.051	9 A		1	1	1	1	1	1	1	1	1	1	1	1	741	
"	6760.006	9 B		1	1	1	1	1	1	1	1	1	1	1	1	741	
"	6760.047	9 A		1	1	1	1	1	1	1	1	1	1	1	1	741	
D 8	6760.015	9 B		1	1	1	1	1	1	1	1	1	1	1	1	741	
"	6760.051	9 A		1	1	1	1	1	1	1	1	1	1	1	1	741	
"	6760.047	9 A		1	1	1	1	1	1	1	1	1	1	1	1	741	
D 9	1201.014	2	1/4 GAS	1	1	1	1	1	1	1	1	1	1	1	1		
D 10	9032.056	147		1	1	1	1	1	1	1	1	1	1	1	1		
D 11	9765.058	9	M 16x2	1	1	1	1	1	1	1	1	1	1	1	1		
D 12	1213.056	9	28x38x7	1	1	1	1	1	1	1	1	1	1	1	1		
D 13	ex 6647.006	-> B		x	x	x	x	x	x	x	x	x	x	x	x	762	no
	-> 6645.263	147 A		1	1	1	1	1	1	1	1	1	1	1	1		
D 14	ex 3030.028	-> B		x	x	x	x	x	x	x	x	x	x	x	x	762	no
	-> 3001.070	9 A		1	1	1	1	1	1	1	1	1	1	1	1		
D 15	4350.006	9		2	2	2	2	2	2	2	2	2	2	2	2		
D 16	1200.003	9	OR 118	1	1	1	1	1	1	1	1	1	1	1	1		
D 17	1213.002	9	28 x 38 x 7	1	1	1	1	1	1	1	1	1	1	1	1		
D 18	9732.060	9	M 6x35	9	9	9	9	9	9	9	9	9	9	9	9		
D 19	4601.029	147		1	1	1	1	1	1	1	1	1	1	1	1		
D 20	8460.083	90		2	2	2	2	2	2	2	2	2	2	2	2		
D 21	ex 3440.004	-> E		x	x	x	x	x	x	x	x	x	x	x	x	763	si
	-> 3440.024	1470 I		1	1	1	1	1	1	1	1	1	1	1	1		
"	3440.035	147		-	-	-	-	-	-	-	-	-	-	-	-		
D 22	1200.002	2	OR 2100	1	1	1	1	1	1	1	1	1	1	1	1		
D 23	7555.003	9	d.5	2	2	2	2	2	2	2	2	2	2	2	2		
D 24	9730.115	9	M 5x14	2	2	2	2	2	2	2	2	2	2	2	2		
D 25	6370.259	1470		1	1	1	1	1	1	1	1	1	1	1	1		
D 26	8980.010	90		1	1	1	1	1	1	1	1	1	1	1	1		
D 27	4350.006	9		1	1	1	1	1	1	1	1	1	1	1	1		
D 28	1770.002	9	M 8x16	8	8	8	8	8	8	8	8	8	8	8	8		
D 29	7565.007	9	d.8,2x14	8	8	8	8	8	8	8	8	8	8	8	8		
D 30	ex 4845.028	-> B		x	x	x	x	x	x	x	x	x	x	x	x	22005	no
	-> 4845.203	158 A		1	1	1	1	1	1	1	1	1	1	1	1		
D 31	4535.015	107 A		1	1	1	1	1	1	1	1	1	1	1	1	22005	
D 35	2457.006	147 B		1	1	1	1	1	1	1	1	1	1	1	1	763	no
D 36	7555.004	9 B		1	1	1	1	1	1	1	1	1	1	1	1	763	
D 37	1760.024	9 B		1	1	1	1	1	1	1	1	1	1	1	1	763	
D 38	6429.173	1470		2	2	2	2	2	2	2	2	2	2	2	2		
D 39	4775.145	147 B		1	1	1	1	1	1	1	1	1	1	1	1	730	
D 40	1301.142	147 B		1	1	1	1	1	1	1	1	1	1	1	1	730	
E 1	3240.004	9	M 5x0,8	1	1	1	1	1	1	1	1	1	1	1	1		
E 2	7555.003	9	d.5	1	1	1	1	1	1	1	1	1	1	1	1		
E 3	7625.005	9	d.5x10	1	1	1	1	1	1	1	1	1	1	1	1		
E 4	5200.880	147		1	1	1	1	1	1	1	1	1	1	1	1		
E 5	1755.014	9	M 5x15	1	1	1	1	1	1	1	1	1	1	1	1		
E 6	5800.072	70		1	1	1	1	1	1	1	1	1	1	1	1		
E 7	2183.031	90		1	1	1	1	1	1	1	1	1	1	1	1		
E 8	ex 9685.126	-> B		x	x	x	x	x	x	x	x	x	x	x	x	22005	no
	-> 9685.128	147 A		1	1	1	1	1	1	1	1	1	1	1	1		
E 9	ex 9652.120	-> B		x	x	x	x	x	x	x	x	x	x	x	x	22005	no
	-> 9652.122	147 A		1	1	1	1	1	1	1	1	1	1	1	1		
E 10	6400.029	90		2	2	2	2	2	2	2	2	2	2	2	2		
E 11	5755.125	147		2	2	2	2	2	2	2	2	2	2	2	2		
E 12	6400.028	90		2	2	2	2	2	2	2	2	2	2	2	2		
E 13	7215.029	90		2	2	2	2	2	2	2	2	2	2	2	2		
E 14	ex 7625.005	-> npd		x	x	x	x	x	x	x	x	x	x	x	x	762	no
	-> 7625.005	9 A		1	1	1	1	1	1	1	1	1	1	1	1		
E 15	ex 1165.006	-> B		x	x	x	x	x	x	x	x	x	x	x	x	762	no
	-> 1919.006	90 A		1	1	1	1	1	1	1	1	1	1	1	1		
E 16		vedi/see Pos.E 30	x	x	x	x	x	x	x	x	x	x	x	x		

 intermotor Motori serie 1 IM 1 IM series engines				vedi Tav. Ric. see Parts Table 1.5302.485		RESTYLING									vedi circolare tecnica see service letter	In intercambiabilità Interchangeability
Pos.	Matricola/Part No.	Note/Remarks	1IM 250-251	1IM 252	1IM 300-301	1IM 302	1IM 350-351	1IM 352	1IM 359	1IM 359 "CEE"	1IM 350	1IM 350	1IM 359			
E 17	ex 4910.031 -> npd B ex=4910.066 -> npd A	vedi/see Pos.E 30	x	x	x	x	x	x	x	x	x	x	x	762	no	
E 18	vedi/see Pos.E 30	x	x	x	x	x	x	x	x	x	x	x	ctvar		
E 19	1165.010 9		1	1	1	1	1	1	1	1	1	1	1			
E 20	9790.047 9		3	3	3	3	3	3	3	3	3	3	3			
E 21	ex 6141.063 -> B -> 6140.415 147 A		x	x	x	x	x	x	x				762	no		
E 22	5204.006 147		1	1	1	1	1	1	1	1	1	1	1			
E 23	7555.004 9	d.6	1	1	1	1	1	1	1	1	1	1	1			
E 24	3240.008 9	M 6x1	1	1	1	1	1	1	1	1	1	1	1			
E 25	7200.064 147		1	1	1	1	1	1	1	1	1	1	1			
E 26	3430.055 90		1	1	1	1	1	1	1	1	1	1	1			
E 27	1165.010 9		1	1	1	1	1	1	1	1	1	1	1			
E 28	7620.017 9		1	1	1	1	1	1	1	1	1	1	1			
E 29	6130.050 9		1	1	1	1	1	1	1	1	1	1	1			
E 30	ex 7362.075 -> B ->=7362.235 147 A Pos.16-17-18-19-25-26-27-28-30.		x	x	x	x	x	x					762	no		
E 31	1301.245 147 A		1	1	1	1	1	1	1	1	1	1	762			
E 32	1111.106 147 A		1	1	1	1	1	1	1	1	1	1	762			
E 33	8430.061 9 A		1	1	1	1	1	1	1	1	1	1	762			
E 34	ex 3348.022 -> npd ex 1011.055 -> B	acc.meccanica dentat.dritta mechanic.ignition straight toothing	x	x	x								707	si		
"	=3348.041 169 A	acc.elettronica dentat.dritta electronic ignit. straight toothing	1	1	1	1	1						762	no		
"	ex 1011.268 -> npd ex 1011.290 -> E ->=3348.040 169 I	acc.elettronica dentat.elicoidale electronic ignit. helical-toothed	x	x		x	x	x	x	x			22005	si		
"	Pos.31-32-33-34.		1	1	1	1	1	1	1	1	1	1	22005	si		
E 35	2183.099 158		-	-	-	-	-	-	-	1	1	1				
E 36	1185.059 9		-	-	-	-	-	-	-	1	1	1				
E 37	5801.560 158		-	-	-	-	-	-	-	1	1	1				
F 1	1450.001 70	standard	1	1	1	1	1	1	1	1	1	1				
"	1450.092 1470	MTC/motorcultivat ribass./short type	1	1	1	1	1	1	1	1	1	1				
F 2	6900.037 70	standard	1	1	1	1	1	1	-	-	-	-				
"	6902.157 147	MTC/motorcultivat	1	-	1	-	1	-	1	-	-	-	22002			
F 3	2135.049 70		1	1	1	1	1	1	1	1	1	1				
F 4	1780.055 9	M 10x45	9	9	9	9	9	9	9	9	9	9				
F 5	7626.028 9	d.10,5x20	9	9	9	9	9	9	9	9	9	9				
F 6	9201.073 147		1	-	-	-	-	-	-	1	-	-				
"	9201.075 158		-	1	-	-	-	-	-	-	-	-				
"	9201.074 155		-	-	1	-	-	-	-	1	-	-				
"	9201.076 157		-	-	1	-	-	-	-	-	-	-				
"	9200.362 158		-	-	-	1	-	1	-	-	1	1				
"	9201.077 159		-	-	-	1	-	-	-	-	-	-				
F 7	2100.006 999		1	1	1	1	1	1	1	1	1	1				

CHAMPL 85C

 intermotor Motori serie 1 IM 1 IM series engines			vedi Tav. Ric. see Parts Table 1.5302.485		RESTYLING										vedi circolare tecnica see service letter	intercambiabilità interchangeability
Pos.	Matricola/Part No.	Note/Remarks	1IM 250-251	1IM 252	1IM 300-301	1IM 302	1IM 350-351	1IM 352	1IM 359	1IM 359 "CEE"	1IM 250	1IM 300	1IM 350	1IM 359		
F 8	5400.007 90		1	1	1	1	1	1	1	1	1	1	1	1		
F 9	=2187.002 147 Pos. 1- 8- 9.		1	1	1	1	1	1	1	-	-	-	-	-		
F 10	2470.054 147		1	1	1	1	1	1	1	1	1	1	1	1		
F 11	9790.039 9	M 6x12	1	1	1	1	1	1	1	-	-	-	-	-		
F 12	3240.003 9	M 4	2	2	2	2	2	2	2	-	-	-	-	-		
F 13	4730.530 147		1	-	-	-	-	-	-	1	-	-	-	-		
"	4730.537 158		-	1	-	1	1	1	1	-	-	-	1	1		
"	4730.531 155		-	-	1	-	-	-	-	-	1	-	-	-		
F 14	1750.037 9	M 4x25	1	1	1	1	1	1	1	-	-	-	-	-		
F 15	8770.029 147		1	1	1	1	1	1	1	-	-	-	-	-		
F 16	ex 1567.035 -> npd	acc.meccanica mechanic.ignition	x	x	x	x	x	x	x	-	-	-	-	-	730	si
	->=1567.097 147	I acc.elettronica electronic ignit.	1	1	1	1	1	1	1	-	-	-	-	-		
"	=1567.154 1470	* MTC/motorcultivat * ribass.acc.eletr. * short type-elect.i	1	1	1	1	1	1	1	-	-	-	-	-		
"	=1567.128 147	** MTC/motorcultivat ** acc.elettronica - con calza metall. protezione cavo ** electronic ignit. with protected coil wire	1	1	1	1	1	1	1	-	-	-	-	-		
	Pos. 1- 8- 9-10-16.															
"	ex 1567.064 -> npd	scherm.-acc.mecc. screened-mech.ign.	x	x	x	x	x	x	x	-	-	-	-	-	730	si
	=1567.096 147	I scherm.-acc.elett. screened-el.ignit.	1	1	1	1	1	1	1	-	-	-	-	-		
	Pos. 8- 9-10-16-20.															
F 17	3526.085 1470		1	1	1	1	1	1	1	1	1	1	1	1		
F 18	7625.007 9	d.6x12	1	1	1	1	1	1	1	1	1	1	1	1		
F 19	1760.006 9	M 6x20	2	2	2	2	2	2	2	2	2	2	2	2		
"	1760.008 9	M 6x25	2	2	2	2	2	2	2	2	2	2	2	2		
F 20	2145.004 1470	scherm./screened	1	1	1	1	1	1	1	-	-	-	-	-		
F 21	1567.201 158	standard	-	-	-	-	-	-	-	1	1	1	1	1		
F 22	7200.067 147	R	1	1	1	1	1	1	1	-	-	-	-	-	730	
F 23	1301.074 147	B	1	1	1	1	1	1	1	-	-	-	-	-	730	
F 24	5040.006 70	B	1	1	1	1	1	1	1	-	-	-	-	-	730	
F 25	2522.010 147	B	1	1	1	1	1	1	1	-	-	-	-	-	730	
G 1	=8103.004 153	standard	1	-	1	-	1	-	1	-	-	-	-	-		
	Pos. 1- 3-11.															
"	ex=8103.012 -> npd	I MTC/motorcultivat	x	x	x	x	x	x	x	-	-	-	-	-	753	si
	->=8103.244 1470	I MTC/motorcultivat	1	-	1	-	1	-	1	-	-	-	-	-		
	Pos. 1- 3-21.															
"	=8103.266 1690	insonor./denoised	1	-	1	-	1	-	1	-	-	-	-	-		
	Pos. 1- 3-10-11.															
"	ex 8103.205 ->	E	x	x	x	x	x	x	x	-	-	-	-	-	22005	no
	-> 8103.273 1470	A MTC/motorcultivat insonor./denoised	1	-	1	-	1	-	1	-	-	-	-	-		
G 2	5401.023 147		1	1	1	1	1	1	1	-	-	-	-	-		
G 3	ex=9043.038 -> npd	A benzina/gasoline	x	x	x	x	x	x	x	-	-	-	-	-	753	no
	->=9080.131 147	A benzina/gasoline	1	1	1	1	1	1	1	-	-	-	-	-		
	Pos. 3-25.															

 intermotor Motori serie 1 IM 1 IM series engines				vedi Tav. Ric. see Parts Table 1.5302.485		RESTYLING										vedi circolare tecnica see service letter	intercambiabilità interchangeability	
Pos.	Matricola/Part No.	Note/Remarks		1IM 350-251	1IM 252	1IM 300-301	1IM 302	1IM 350-351	1IM 352	1IM 359	1IM 359 "CEE"	1IM 250	1IM 300	1IM 350	1IM 359			
G 4	4775.469 1470			1	1	1	1	1	1	1	-	-	-	-	-			
G 5	7555.003 9	d.5		2	2	2	2	2	2	2	-	-	-	-	-			
G 6	3240.008 9	M 6x1		2	2	2	2	2	2	2	-	-	-	-	-			
G 7	9375.196 7000			1	1	1	1	1	1	1	-	-	-	-	-			
G 8	7500.018 9			2	2	2	2	2	2	2	-	-	-	-	-			
G 9	9790.039 9	M 6x12		2	2	2	2	2	2	2	-	-	-	-	-			
G 10	4580.076 44			-	-	-	-	-	-	1	-	-	-	-	-			
G 11	7755.055 147			1	-	1	-	1	-	1	-	-	-	-	-			
"	7755.102 1580			-	-	-	-	-	-	1	-	-	-	-	-			
G 12	7500.018 9			2	2	2	2	2	2	2	-	-	-	-	-			
G 13	9790.039 9	M 6x12		2	2	2	2	2	2	2	-	-	-	-	-			
G 14	4501.107 158			2	2	2	2	2	2	2	-	-	-	-	-			
G 15	6927.272 1690			1	1	1	1	1	1	1	-	-	-	-	-			
G 16	2942.133 158			1	-	1	-	1	-	1	-	-	-	-	-			
G 17	4470.013 158			1	1	1	1	1	1	1	-	-	-	-	-			
G 18	7565.004 9	A 6,1x11		2	2	2	2	2	2	2	-	-	-	-	-			
G 19	3240.008 9	M 6x1		2	2	2	2	2	2	2	-	-	-	-	-			
G 20	2151.199 1470	0,90		1	-	1	-	1	-	1	-	-	-	-	-			
"	2151.228 147	0,90		1	-	1	-	1	-	1	-	-	-	-	-			
"	2151.237 155	0,90		1	-	1	-	1	-	1	-	-	-	-	-			
"	2151.246 147	0,94		1	1	1	1	1	1	1	-	-	-	-	-			
"	2151.247 155	0,98		1	-	1	-	1	-	1	-	-	-	-	-			
"	2151.248 1690	0,94		-	-	-	-	1	1	1	-	-	-	-	-			
"	2151.249 1690	0,98		-	-	-	-	1	1	1	-	-	-	-	-			
"	2151.250 159	1,01		-	-	-	-	1	-	-	-	-	-	-	-			
"	2151.251 147	0,94		1	1	1	1	1	-	-	-	-	-	-	-			
"	2151.252 157	0,98		1	-	1	-	1	-	1	-	-	-	-	-			
"	2151.253 169	0,98		-	-	-	-	1	1	1	-	-	-	-	-			
"	2151.254 169	0,98		-	-	-	-	1	1	1	-	-	-	-	-			
"	2151.255 159	1,01		-	-	-	-	1	-	-	-	-	-	-	-			
"	2151.256 147	0,94		1	1	1	1	1	-	-	-	-	-	-	-			
"	2151.257 157	0,98		-	1	1	-	-	-	-	-	-	-	-	-			
"	2151.258 169	0,94		-	-	-	-	1	1	1	-	-	-	-	-			
"	2151.259 169	0,98		-	-	-	-	1	1	1	-	-	-	-	-			
"	2151.260 159	1,01		-	-	-	-	1	-	-	-	-	-	-	-			
per identificazione carburatori vedere tabella in ultima pagina see carburator list to identify (last page)																		
G 21	5981.059 1470	A MTC/motorcultivat insonor./denoised		1	-	1	-	1	-	1	-	-	-	-	-	22004		
G 22	4501.108 158			1	2	1	2	1	2	1	1	1	1	1	1			
G 23	9708.002 89			-	1	-	1	-	1	-	-	-	-	-	-			
G 25	vedi/see Pos.G 3		x	x	x	x	x	x	x	-	-	-	-	-			
G 26	=8103.003 147 Pos.26-27-28-29-42-43-44-45.			-	1	-	1	-	1	-	-	-	-	-	-			
G 27	9043.048 147	benzina/gasoline		1	-	1	-	1	-	1	-	-	-	-	-			
G 28	=9043.050 147 Pos.28-29.	petrolio/kerosene		1	-	1	-	1	-	1	-	-	-	-	-			
G 29	1200.015 9	OR 137		-	1	-	1	-	1	-	-	-	-	-	-			
G 30	3630.057 9			3	-	3	-	3	-	3	-	-	-	-	-			
G 31	9375.196 7000	MTC/motorcultivat		1	-	1	-	1	-	1	-	-	-	-	-			
G 32	1760.001 9	M 6x10		1	-	1	-	1	-	1	-	-	-	-	-			
G 33	9375.196 7000	MTC/motorcultivat		1	-	1	-	1	-	1	-	-	-	-	-			
G 34	8546.037 1470	MTC/motorcultivat		1	-	1	-	1	-	1	-	-	-	-	-			
G 35	9375.108 1470	MTC/motorcultivat		1	-	1	-	1	-	1	-	-	-	-	-			
G 36	3617.037 1470			1	-	1	-	1	-	1	-	-	-	-	-			
G 37	9375.193 20	MTC/motorcultivat		1	-	1	-	1	-	1	-	-	-	-	-			

 intermotor Motori serie 1 IM 1 IM series engines			vedi Tav. Ric. see Parts Table 1.5302.485		RESTYLING								vedi circolare tecnica see service letter	intercambiabilità interchangeability
Pos.	Matricola/Part No.	Note/Remarks	IM 250-251	IM 252	IM 300-301	IM 302	IM 350-351	IM 352	IM 359	IM 359 "CEE"	IM 250	IM 300	IM 350	IM 359
G 38	3617.018	9	1	1	1	1	1	1	1	1	1	1	1	1
G 39	3630.057	9	1	1	1	1	1	1	1	1	1	1	1	1
G 40	9375.192	18	1	1	1	1	1	1	1	1	1	1	1	1
G 41	7755.062	1470	1	1	1	1	1	1	1	1	1	1	1	1
G 42	4775.052	45	1	1	1	1	1	1	1	1	1	1	1	1
G 43	7755.060	147	1	1	1	1	1	1	1	1	1	1	1	1
G 44	7565.004	9	1	1	1	1	1	1	1	1	1	1	1	1
G 45	1760.014	9	1	1	1	1	1	1	1	1	1	1	1	1
G 46	4501.107	158	1	1	1	1	1	1	1	1	2	2	2	2
G 47	9730.012	9	1	1	1	1	1	1	1	1	2	2	2	2
"	9732.078	9	1	1	1	1	1	1	1	1	2	2	2	2
G 48	4501.123	158	1	1	1	1	1	1	1	1	1	1	1	1
G 49	6760.103	9	1	1	1	1	1	1	1	1	2	2	2	2
G 50	7565.004	9	1	1	1	1	1	1	1	1	2	2	2	2
G 51	3240.008	9	1	1	1	1	1	1	1	1	2	2	2	2
G 52	2151.269	155	1	1	1	1	1	1	1	1	1	1	1	1
"	2151.268	158	1	1	1	1	1	1	1	1	1	1	1	1
"	2151.267	169	1	1	1	1	1	1	1	1	1	1	1	1
G 53	4501.124	158	1	1	1	1	1	1	1	1	1	1	1	1
G 54	5401.110	183	1	1	1	1	1	1	1	1	1	1	1	1
G 55	9043.079	158	1	1	1	1	1	1	1	1	1	1	1	1
G 56	3240.004	9	1	1	1	1	1	1	1	1	1	1	1	1
G 57	7565.003	9	1	1	1	1	1	1	1	1	1	1	1	1
G 58	8545.575	158	1	1	1	1	1	1	1	1	1	1	1	1
G 59	6585.069	224	1	1	1	1	1	1	1	1	1	1	1	1
"	6585.087	224	1	1	1	1	1	1	1	1	1	1	1	1
G 60	7625.005	9	1	1	1	1	1	1	1	1	1	1	1	1
G 61	9730.096	9	1	1	1	1	1	1	1	1	1	1	1	1
G 62	8103.297	158	1	1	1	1	1	1	1	1	1	1	1	1
G 63	3240.132	9	1	1	1	1	1	1	1	1	1	1	1	1
G 64	4580.076	183	1	1	1	1	1	1	1	1	1	1	1	1
G 65	3203.050	9	1	1	1	1	1	1	1	1	2	2	2	2
G 66	7625.093	9	1	1	1	1	1	1	1	1	2	2	2	2
G 67	7701.154	9	1	1	1	1	1	1	1	1	8	8	8	8
G 68	3527.427	158	1	1	1	1	1	1	1	1	2	2	2	2
G 69	8865.183	158	1	1	1	1	1	1	1	1	1	1	1	1
G 70	3527.437	158	1	1	1	1	1	1	1	1	2	2	2	2
G 71	7625.093	9	1	1	1	1	1	1	1	1	2	2	2	2
G 72	9732.078	9	1	1	1	1	1	1	1	1	2	2	2	2
G 73	3630.057	9	1	1	1	1	1	1	1	1	1	1	1	1
G 74	7755.108	158	1	1	1	1	1	1	1	1	1	1	1	1
G 75	9375.934	158	1	1	1	1	1	1	1	1	1	1	1	1
G 76	3855.139	158	1	1	1	1	1	1	1	1	1	1	1	1
G 77	9375.936	158	1	1	1	1	1	1	1	1	1	1	1	1
G 78	9375.935	158	1	1	1	1	1	1	1	1	1	1	1	1
G 79	vedi/see Pos. 77	1	1	1	1	1	1	1	1	x	x	x	x
G 80	3730.098	1580	1	1	1	1	1	1	1	1	1	1	1	1
H 1	6100.029	147	1	1	1	1	1	1	1	1	1	1	1	1
"	6100.028	158	1	1	1	1	1	1	1	1	1	1	1	1
H 3	9820.112	9	1	1	1	1	1	1	1	1	1	1	1	1
H 4	5801.141	147	1	1	1	1	1	1	1	1	1	1	1	1
H 6	7996.014	147	1	1	1	1	1	1	1	1	1	1	1	1
H 8	3588.028	147	1	1	1	1	1	1	1	1	1	1	1	1
"	3588.027	158	1	1	1	1	1	1	1	1	1	1	1	1
"	3588.035	1580	1	1	1	1	1	1	1	1	1	1	1	1
"	3588.034	74	1	1	1	1	1	1	1	1	1	1	1	1
H 9	7996.013	999	1	1	1	1	1	1	1	1	1	1	1	1
H 10	1200.172	9	1	1	1	1	1	1	1	1	1	1	1	1
H 11	4126.016	147	1	1	1	1	1	1	1	1	1	1	1	1
"	4126.072	1580	1	1	1	1	1	1	1	1	1	1	1	1
"	4126.067	74	1	1	1	1	1	1	1	1	1	1	1	1

 intermotor Motori serie 1 IM 1 IM series engines			vedi Tav. Ric. see Parts Table 1.5302.485		RESTYLING								vedi circolare tecnica see service letter	intercambiabilità interchangeability		
Pos.	Matricola/Part No.	Note/Remarks	1IM 250-251	1IM 252	1IM 300-301	1IM 302	1IM 350-351	1IM 352	1IM 359	1IM 359 "CEE"	1IM 250	1IM 300	1IM 350	1IM 359		
H 12	1200.173 9		1	1	1	1	1	1	1	1	-	-	-	-		
H 13	6610.004 147		1	1	1	1	1	1	1	1	-	-	-	-		
H 14	4126.077 147	0,94 max./main jet	1	1	1	1	1	1	1	1	-	-	-	-		
"	4126.017 147	0,90 "	1	1	1	1	1	1	1	1	-	-	-	-		
"	4126.075 169	0,98 "	1	1	1	1	1	1	1	1	-	-	-	-		
"	4126.074 159	1,01 "	1	1	1	1	1	1	1	1	-	-	-	-		
"	4126.071 1580	1,05 "	1	1	1	1	1	1	1	1	-	-	-	-		
"	4126.069 74	1,05 "	1	1	1	1	1	1	1	1	-	-	-	-		
per identificazione getto max vedi tabella carburatori in ultima pagina see carburetor list to identify main jet (last page)																
H 15	6610.003 147		1	1	1	1	1	1	1	1	-	-	-	-		
H 19	3730.041 10		1	1	1	1	1	1	1	1	-	-	-	-		
"	3730.042 100		1	1	1	1	1	1	1	1	-	-	-	-		
H 20	6491.021 147		1	1	1	1	1	1	1	1	-	-	-	-		
"	6491.029 147		1	1	1	1	1	1	1	1	-	-	-	-		
H 22	4105.009 147		1	1	1	1	1	1	1	1	-	-	-	-		
H 23	6231.077 999		1	1	1	1	1	1	1	1	-	-	-	-		
H 24	9850.073 9		1	1	1	1	1	1	1	1	-	-	-	-		
H 25	5801.141 147		1	1	1	1	1	1	1	1	-	-	-	-		
H 26	9820.113 9		1	1	1	1	1	1	1	1	-	-	-	-		
H 30	5801.142 147		1	1	1	1	1	1	1	1	-	-	-	-		
H 31	6100.035 147		1	1	1	1	1	1	1	1	-	-	-	-		
"	6100.030 147		1	1	1	1	1	1	1	1	-	-	-	-		
H 32	8180.167 74		1	1	1	1	1	1	1	1	-	-	-	-		
H 33	4126.080 155	0,75	1	1	1	1	1	1	1	1	-	-	-	-		
"	4126.081 158	0,78	1	1	1	1	1	1	1	1	-	-	-	-		
"	4126.082 169	0,88	1	1	1	1	1	1	1	1	-	-	-	-		
I 1	7481.025 9		2	2	2	2	2	2	2	2	2	2	2	2		
I 2	7195.003 70		1	1	1	1	1	1	1	1	-	-	-	-		
I 3	5640.010 147		1	1	1	1	1	1	1	1	-	-	-	-		
I 4	7500.018 9		2	2	2	2	2	2	2	2	2	2	2	2		
I 5	9790.039 9	M 6x12	2	2	2	2	2	2	2	2	2	2	2	2		
I 6	9790.039 9	M 6x12	4	4	4	4	4	4	4	4	4	4	4	4		
I 7	9790.039 9	M 6x12	1	1	1	1	1	1	1	1	1	1	1	1		
I 8	ex 2920.074 -> npd		x	x	x	x	x	x	x	x	-	-	-	-		
"	-> 2920.170 147	I standard	1	1	1	1	1	1	1	1	-	-	-	-	ctvar	si
"	2920.117 1470	insonor./denoised	-	-	-	-	-	-	-	-	-	-	-	-		
"	2920.173 147	insonor./denoised	-	-	-	-	-	-	-	-	-	-	-	-		
I 9	4776.059 1470		1	1	1	1	1	1	1	1	1	1	1	1		
I 10	=2568.053 147	standard	1	1	1	1	1	1	1	1	-	-	-	-		
"	=2568.064 147	avv.el./el.start.	1	1	1	1	1	1	1	1	-	-	-	-		
"	=2569.472 1690	insonor./denoised	-	-	-	-	-	-	-	-	-	-	-	-		
"	=2569.546 147	insonor.- avv.el. denoised-el.start.	-	-	-	-	-	-	-	-	-	-	-	-		
"	Pos. 2- 3-10.															
"	2569.571 147	standard	-	-	-	-	-	-	-	-	1	1	1	1		
"	2569.575 147	insonor./denoised	-	-	-	-	-	-	-	-	1	1	1	1		
"	2569.598 147	avv.el. e spia ol el.start-oil aler	-	-	-	-	-	-	-	-	1	1	1	1		
"	2569.600 147	insonor.- avv.cl. pred.spia olio denoised-el.start. oil alert fitted	-	-	-	-	-	-	-	-	1	1	1	1		
I 11	9790.037 9	M 6x8	4	4	4	4	4	4	4	4	4	4	4	4		

 intermotor Motori serie 1 IM 1 IM series engines			vedi Tav. Ric. see Parts Table 1.5302.485		RESTYLING								vedi circolare tecnica see service letter	intercambiabilità interchangeability		
Pos.	Matricola/Part No	Note/Remarks	IM 250-251	IM 252	IM 300-301	IM 302	IM 350-351	IM 352	IM 359	IM 359 "CEE"	IM 250	IM 300	IM 350	IM 359		
I 12	7500.018	9	2	2	2	2	2	2	2	2	2	2	2	2		
I 13	8900.488	158	-	-	-	-	-	-	-	-	1	1	1	1		
I 14	5041.256	158	-	-	-	-	-	-	-	-	1	1	1	1		
I 15	1185.059	9	-	-	-	-	-	-	-	-	1	1	1	1		
I 16	2183.100	158	-	-	-	-	-	-	-	-	1	1	1	1		
I 17	2185.921	158	-	-	-	-	-	-	-	-	1	1	1	1		
I 18	2185.922	158	-	-	-	-	-	-	-	-	1	1	1	1		
I 19	1760.030	9	M 6x20								1	1	1	1		
I 20	3203.050	9	M 6x1								1	1	1	1		
I 21	8510.150	158									1	1	1	1		
I 22	5715.060	9									1	1	1	1		
I 24	8345.056	158									1	1	1	1		
I 25	2569.189	1470	avv.el./el.start.	1	1	1	1	1	1	-	-	-	-	-		
"	2569.188	1470	avv.el. e spia ol el.start-oil aler	1	1	1	1	1	1	-	-	-	-	-		
I 26	ex 8345.008 -> ->=8345.039 1470 Pos.26-27.	E I		X	X	X	X	X	X						763	si
I 27	vedi/see Pos.I 26		X	X	X	X	X	X							
I 28	7540.010	147		1	1	1	1	1	1	-	-	-	-			
I 29	5096.064	147		1	1	1	1	1	1	1	1	1	1	1		
L 1	vedi/see Pos.L 5		X	X	X	X	X	X	X	X	X	X	X		
L 2	ex 5201.049 -> -> 5200.606 147	B A		X	X	X	X	X	X						756	no
L 3	3240.004	9	M 5x0,8	1	1	1	1	1	1	1	1	1	1	1		
L 4	9790.028	9	M 5x10	2	2	2	2	2	2	2	2	2	2	2		
L 5	ex 2691.053 -> npd ->=2750.282 147	I	Pos. 1- 2- 3- 5-10-11-12-13-14.	X	X	X	X	X	X						756	si
L 6	1165.006	9		1	1	1	1	1	1	1	1	1	1	1		732
L 7	5200.202	1470		1	1	1	1	1	1	1	1	1	1	1		732
L 8	ex 5680.067 -> npd -> 5680.119 147	I		X	X	X	X	X	X						ctvar	si
L 9	6140.137	1470		1	1	1	1	1	1	1	1	1	1	1		732
L 10	3203.039	9	M 5	1	1	1	1	1	1	1	1	1	1	1		
L 11	7626.017	9	d.5,3x9,5	1	1	1	1	1	1	1	1	1	1	1		
L 12	vedi/see Pos.L 5		X	X	X	X	X	X	X	X	X	X	X		
L 13	vedi/see Pos.L 5		X	X	X	X	X	X	X	X	X	X	X		
L 14	6371.013	90		1	1	1	1	1	1	1	1	1	1	1		
L 15	5655.047	147	std.	1	1	1	1	1	1	1	1	1	1	1		
"	5655.108	1470	per gruppi elettr. for generat.sets	1	1	1	1	1	1	1	1	1	1	1		
L 16	1760.034	9	M 6x25 std.	1	1	1	1	1	1	1	1	1	1	1		
"	1760.086	9	M 6x30 per gruppi elettr. for generat.sets	1	1	1	1	1	1	1	1	1	1	1		
L 17	3240.008	9	M 6x1	1	1	1	1	1	1	1	1	1	1	1		732
L 18	1557.058	147		1	1	1	1	1	-	-	-	-	-	-		732
L 19	1760.082	9	M 6x35	1	1	1	1	1	1	1	1	1	1	1		732
L 20	4680.039	90		1	1	1	1	1	1	1	1	1	1	1		
L 21	=7951.109 147 Pos.21-24.			1	1	1	1	1	1	1	1	1	1	1		
L 22	5976.001	90		1	1	1	1	1	1	1	1	1	1	1		
L 23	4680.039	90		1	1	1	1	1	1	1	1	1	1	1		

 intermotor Motori serie 1 IM 1 IM series engines			vedi Tav. Ric. see Parts Table 1.5302.485		RESTYLING										vedi circolare tecnica see service letter	intercambiabilità interchangeability
Pos.	Matricola/Part No.	Note/Remarks	1IM 250-251	1IM 252	1IM 300-301	1IM 302	1IM 350-351	1IM 352	1IM 359	1IM 359 "CEE"	1IM 250	1IM 300	1IM 350	1IM 359		
L 24	9695.013	180	1	1	1	1	1	1	1	1	1	1	1	1		
L 25	2690.046	90	1	1	1	1	1	1	1	1	-	-	-	-		
"	2690.288	1470	1	1	1	1	1	1	1	1	1	1	1	1		
L 26	9790.039	9	1	1	1	1	1	1	1	1	1	1	1	1		
L 27	9580.023	180	1	1	1	1	1	1	1	1	-	-	-	-		
L 28	2691.051	147	1	1	1	1	1	1	1	1	1	1	1	1		
L 29	5830.119	10	1	1	1	1	1	1	1	1	1	1	1	1		
L 30	9180.011	70	1	1	1	1	1	1	1	1	1	1	1	1		
L 31	3240.009	9	1	1	1	1	1	1	1	1	1	1	1	1		
M 1	8140.097	1470	1	1	1	1	1	1	1	1	1	1	1	1		
M 2	6456.009	1470	1	1	1	1	1	1	1	1	1	1	1	1		
M 3	ex 6360.043	-> E	x	x	x	x	x	x							747	no
	ex 8900.154	-> npd	x	x	x	x	x	x							752	si
	-> 8815.062	1470 I	1	1	1	1	1	1	1	1	1	1	1	1		
M 4	4908.033	147	1	1	1	1	1	1	1	1	1	1	1	1		
M 5	8310.043	147	1	1	1	1	1	1	1	1	1	1	1	1		
M 6	8815.063	1470	1	1	1	1	1	1	1	1	1	1	1	1		
M 7	6617.009	147	1	1	1	1	1	1	1	1	1	1	1	1		
M 9	9599.045	147	1	1	1	1	1	1	1	1	1	1	1	1		
M 10	5041.019	9000	1	1	1	1	1	1	1	1	1	1	1	1		
M 11	1165.006	9	1	1	1	1	1	1	1	1	1	1	1	1		
M 12	3410.054	147	1	1	1	1	1	1	1	1	-	-	-	-		
M 13	2136.022	1470	1	1	1	1	1	1	1	1	-	-	-	-		
M 14	3410.054	1470	1	1	1	1	1	1	1	1	-	-	-	-		
M 15	6366.004	90	1	1	1	1	1	1	1	1	-	-	-	-		
"	5025.094	196	-	-	-	-	-	-	-	-	2	2	2	2		
M 16	7100.244	1470	1	1	1	1	1	1	1	1	-	-	-	-		
"	7100.371	196	-	-	-	-	-	-	-	-	1	1	1	1		
M 17	5801.179	1470	1	1	1	1	1	1	1	1	-	-	-	-		
"	5801.539	196	-	-	-	-	-	-	-	-	1	1	1	1		
M 18	3430.101	1470	1	1	1	1	1	1	1	1	-	-	-	-		
M 19	9790.037	9	2	2	2	2	2	2	2	2	-	-	-	-		
M 20	6961.014	147	1	1	1	1	1	1	1	1	-	-	-	-		
"	6961.106	147	-	-	-	-	-	-	-	-	1	1	1	1		
M 21	7555.004	9	4	4	4	4	4	4	4	4	4	4	4	4		
M 22	1760.005	9	4	4	4	4	4	4	4	4	4	4	4	4		
M 23	5680.064	1470	1	1	1	1	1	1	1	1	-	-	-	-		
"	5660.066	196	-	-	-	-	-	-	-	-	1	1	1	1		
M 24	5725.041	1470	1	1	1	1	1	1	1	1	-	-	-	-		
"	5590.026	196	-	-	-	-	-	-	-	-	1	1	1	1		
M 25	4055.005	90	1	1	1	1	1	1	1	1	-	-	-	-		
"	4904.038	196	-	-	-	-	-	-	-	-	1	1	1	1		
M 26	=1471.069	1470	1	1	1	1	1	1	1	1	-	-	-	-		
"	=1471.085	158	1	1	1	1	1	1	1	1	-	-	-	-		
	Pos.11-12-13-14-15-16-17-18-23-24-25-26.	MTC/motorcultivat insonor./denoised														
M 27	7625.008	9	4	4	4	4	4	4	4	4	-	-	-	-		
M 28	9790.039	9	2	2	2	2	2	2	2	2	-	-	-	-		
M 29	=1471.089	196	-	-	-	-	-	-	-	-	1	1	1	1		
	Pos.11-15-16-17-23-24-25-29.															
M 30	2501.129	196	-	-	-	-	-	-	-	-	4	4	4	4		
M 31	6927.358	196	-	-	-	-	-	-	-	-	1	1	1	1		
M 32	9730.309	9	-	-	-	-	-	-	-	-	4	4	4	4		
M 33	ex 6607.015	-> B	x	x	x	x	x	x							757	no
	ex 7362.225	-> npd	x	x	x	x	x	x							764	si
	-> 7362.255	1830 12V 8,5A	1	1	1	1	1	1	1	1	1	1	1	1		

 intermotor Motori serie 1 IM 1 IM series engines				vedi Tav. Ric. see Parts Table 1.5302.485		RESTYLING								vedi circolare tecnica see service letter	intercambiabilità interchangeability	
Pos.	Matricola/Part No.	Note/Remarks	IM 250-281	IM 252	IM 300-301	IM 302	IM 350-351	IM 352	IM 359	IM 359 "CEE"	IM 250	IM 300	IM 350	IM 359		
M 34	7362.187 540	per altern.luce for lighting alt.	1	1	1	1	1	1	1	1	1	1	1	1		
M 35	ex 5840.058 -> npd -> 5840.119 1470		x	x	x	x	x	x							747	si
M 36	4570.034 1580		1	1	1	1	1	1	1	1	1	1	1	1		
N 1	2760.017 9	M 4,2x10								3						
N 2	7625.003 9	d. 4x8								2						
N 3	8865.151 1580									1						
N 4	5981.058 1580		1	1	1	1	1	1	1							
N 5	3300.190 1470		2	2	2	2	2	2	2	2	2	2	2	2		
N 6	7986.024 1470		1	1	1	1	1	1	1							
N 7	9790.047 9	M 6x16								4						
N 8	7626.001 9	d. 6,5x16								4						
N 9	8506.078 1580		1	1	1	1	1	1	1							
N 10	3617.172 1580									1						
N 11	8506.077 1580		1	1	1	1	1	1	1							
N 12	8345.038 1580									1						
N 13	2185.692 1580				1	1			1							

 intermotor Motori serie 1 IM 1 IM series engines		vedi Tav. Ric. see Parts Table 1.5302.485		1 IM 250-251	1 IM 252	1 IM 300-301	1 IM 302	1 IM 350-351	1 IM 352	1 IM 359	1 IM 359 "CEE"	1 IM 250	1 IM 300	1 IM 350	1 IM 359	vedi circolare tecnica see service letter	intercambiabilità Interchangeability
POS. Matricola/Part No.		Note/Remarks															
TABELLA CARBURATORI vedi Circolare Tecnica 22005 CARBURETOR LIST see Service Letter 22005																	
Applicabilità Application	Antemodif./Prior to improv.					Postmodif./After improvem.											
	Motore Engine	Carburat Carburet	Tipo Type FVCA	Getto max. Main ject		Carburat Carburet	Tipo Type FVCA	Getto max. Main ject									
per filtro aria a secco for dry air cleaner	IM 250	2151.237	22-17	4126.017	90	2151.246	22-17	4126.077	94								
	IM 300	"				"											
	IM 252	"				2151.247	22-17	4126.075	98								
	IM 350	2151.239	24-19	4126.018	92	2151.246	22-17	4126.077	94								
	IM 359	2151.236	26-21	4126.073	103	2151.249	24-19	4126.075	98								
	IM 302	2151.237	22-17	4126.017	90	2151.247	22-17	4126.075	98								
per filtro aria a bagno d'olio for oil bath air cleaner	IM 250	2151.237	22-17	4126.017	90	2151.237	22-17	4126.017	90								
	IM 300	"				"											
	IM 350	2151.239	24-19	4126.018	92	"											
	IM 359	"				2151.248	24-19	4126.077	94								
	IM 252	2151.237	22-17	4126.017	90	2151.246	22-17	4126.077	94								
	IM 302	"				"											
per filtro aria a secco e starter a distanza for dry air cleaner and remote starter	IM 250	2151.199	22-17	4126.017	90	2151.251	22-17	4126.077	94								
	IM 300	"				"											
	IM 350	2151.251	22-17	4126.077	94	"											
	IM 359	"				2151.254	24-19	4126.075	98								
	IM 252	2151.199	22-17	4126.017	90	2151.252	22-17	4126.075	98								
	IM 302	"				"											
per filtro aria a bagno d'olio e starter a distanza for oil bath air cleaner and remote starter	IM 250	2151.199	22-17	4126.017	90	2151.199	22-17	4126.017	90								
	IM 300	"				"											
	IM 350	2151.251	22-17	4126.077	94	"											
	IM 359	"				2151.253	24-19	4126.075	98								
	IM 252	2151.199	22-17	4126.017	90	2151.251	22-17	4126.077	94								
	IM 302	"				"											
per filtro aria a secco e alim. a G.P.L. for dry air cleaner and L.P.G. feeding	IM 250	2151.228	22-17	4126.017	90	2151.256	22-17	4126.077	94								
	IM 300	"				"											
	IM 350	2151.229	24-19	4126.018	92	"											
	IM 359	2151.245	26-21	4126.073	103	2151.259	24-19	4126.075	98								
	IM 252	2151.228	22-17	4126.017	90	2151.257	22-17	4126.075	98								
	IM 302	"				"											
per filtro aria a bagno d'olio e alim. a G.P.L. for oil bath air cleaner and L.P.G. feeding	IM 250	2151.228	22-17	4126.017	90	2151.228	22-17	4126.017	90								
	IM 300	"				"											
	IM 350	2151.229	24-19	4126.018	92	"											
	IM 359	"				2151.258	24-19	4126.077	94								
	IM 252	2151.228	22-17	4126.017	90	2151.256	22-17	4126.077	94								
	IM 302	"				"											
fine/end	IM 352	2151.229	24-19	4126.018	92	2151.258	24-19	4126.077	94								

Gruppo motori		Tipo		pag. 1/2
Groupe moteurs		Type		
Engine group	22	Type	1 IM	
Motorgruppe		Typ		
Grupo motores		Tipo		

- Registrazione gioco valvole tramite spessori.
- Réglage jeu soupape par des cales.
- Valve play adjustment by shims.
- Einstellung des Ventilspiels mittels Beilagescheibe.
- Regulación juego válvulas por medio de espesores.

Antemodifica Avant la modification Prior to improvement Vor der Änderung Antes de la modificación	Après la modification After improvement Nach der Änderung Después de la modificación
---	---

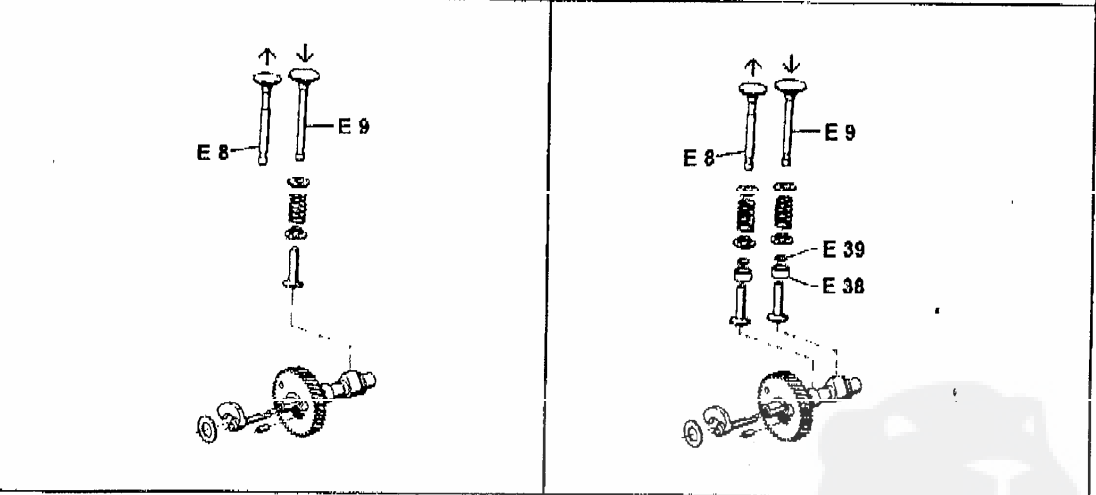
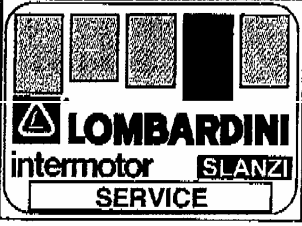

FIG.	MATR./REF./P.NO	Q.ty	FIG.	MATR./REF./P.NO	Q.ty
E 8	9685.128 147 E B	1	E 8	9685.154 158 A	1
E 9	9652.122 147 (*)	1	E 9	9652.162 158 A	1
			E 38	2135.102 226 A	2
			E 39	8335.197 226 A	0,1
			„	8335.198 226 A	0,2

Attuazione da A partir de Starting from Gültig ab Actualización desde 7817934	(*) Non più disponibile Non plus disponible No longer available Nicht mehr verfügbar No se suministra mas
---	---------------	---



CIRCOLARE TECNICA
CIRCULAIRE TECHNIQUE
SERVICE LETTER
TECHNISCHES RUNDSCHREIBEN
CIRCULAR TECNICA

Compilazione <i>[Signature]</i>	Sez.Sect. 22
	N. 22021
Visto/approvaZIONE <i>[Signature]</i>	Data 15/12/99
	M.A.T. 50511
Modello 50722	

Il gioco valvola prescritto ($0,15 \pm_{0,05}^{0,00}$) era finora ottenuto molando al montaggio lo stelo delle valvole e/o fresando la sede finquanto necessario.
Ora il gioco si ottiene inserendo, tra valvola e punteria, alcuni spessori da 0,1 e da 0,2 mm alloggiati all'interno di uno scodellino di contenimento, in quanto le nuove valvole sono più corte di $2 \pm_{0,05}^{0,00}$ mm rispetto a quelle antemodifica.
I particolari postmodifica non sono singolarmente intercambiabili con quelli antemodifica, che sono forniti ad esaurimento.

Le jeu soupapes prescrit ($0,15 \pm_{0,05}^{0,00}$) était obtenu jusqu'à présent en meulant pendant le montage la tige des soupapes et/ou en fraisant le siège le nécessaire.
Maintenant le jeu s'obtient en insérant entre la soupape et le poussoir quelques cales d'épaisseur 0,1 et 0,2 mm contenues dans une cuvette, car les soupapes nouvelles sont plus courtes de $2 \pm_{0,05}^{0,00}$ mm par rapport à les anciennes.
Les pièces après la modification ne sont pas interchangeables entre elles avec les anciennes, qui sont fournies jusqu'à l'épuisement du stock.

The correct valve play ($0,15 \pm_{0,05}^{0,00}$) has been till now obtained by grinding the valve stem and/or by milling the seat during assembly.
At present the play can be obtained putting between valve and tappet some 0,1 and 0,2 mm shims contained in a special cap, as the new valves are $2 \pm_{0,05}^{0,00}$ mm shorter than the old ones.
After improvement parts are not separately interchangeable with prior to improvement ones, which are supplied until stock exhaustion.

Das korrekt Ventilspiel ($0,15 \pm_{0,05}^{0,00}$) wurde bisher durch Abschleifen des Ventilschaftes oder durch Einschleifen des Ventils eingestellt.
Bei dem neuen System werden Scheiben von 0,1 und 0,2 mm in eine spezielle Kappe eingelegt und das Ventilspiel damit eingestellt.
Diese spezielle Kappe wird dem Ventil hinzugefügt. Dadurch werden die neuen Ventile um $2 \pm_{0,05}^{0,00}$ mm kürzer als die alten.
Die neuen Teile sind einzeln nicht austauschbar mit den alten, die bis zur Erschöpfung des Lagerbestandes geliefert werden können.

El juego de la válvula necesario ($0,15 \pm_{0,05}^{0,00}$) se conseguía hasta ahora rebajando con una muela el vástago de la válvula y/o fresando el asiento de la válvula hasta conseguir el juego establecido.
Ahora el juego se obtiene insertando, entre la válvula y el impulsor, los espesores que se precisen de 0,1 y de 0,2 mm. y se alojan en el interior de una cazoleta que hace la función de contenedor de los espesores, por tanto las nuevas válvulas son mas cortas en $2 \pm_{0,05}^{0,00}$ mm. respecto a las anteriores a la modificación.
Las piezas de recambio anteriores y posteriores a la modificación no son intercambiables unitariamente entre sí, deben sustituirse en conjunto; las anteriores a la modificación, se suministran hasta agotar existencias.

Autersstr. 12b

S.A.V.

02124 1040

Tavole ricambi interessate alla modifica:

Tableaux pièces détachées concernant la modification:

Improvement applies to the following spare parts table:

Von der Änderung betroffene Ersatzteillisten:

Tablas repuestos referidas a la modificación:

1.5302.485

Gruppo motori		Tipo	
Groupe moteurs		Type	1IM 250 - 251 - 252
Engine group	22	Type	1IM 300 - 301 - 302
Motorgruppe		Typ	1IM 350 - 351 - 352
Grupo motores		Tipo	1IM 359

- Modificate valvole, sedi, guide valvole aspirazione, alberi a camme e getti max.
- Modification soupapes, sièges, guides soupapes admission, arbres à cames et gicleur maxi.
- Modification of valves, seats, intake valve guides, camshafts and main jets.
- Änderung von : Ventilen, Ventilsitzen, Einlaßventilführung, Nockenwelle und Hauptdüse.
- Modificación válvula, asiento, guía válvula admisión, efe de levas y surtidor de máx.

I basamenti antemodifica sono forniti ad esaurimento e poi sostituiti da quelli postmodifica (completi di guide e sedi).

Sui nuovi basamenti devono essere utilizzati valvole, guarnizioni, piattelli e getti del max postmodifica. I carburatori variano matricola per la modifica dei getti (tutti gli altri componenti rimangono invariati) (vedere tabella carburatori a pag. 4/6 e 5/6). Gli alberi a camme tipo vecchio sono forniti ad esaurimento e poi sostituiti dai nuovi intercambiabili. Si può montare la guarnizione valvola aspirazione postmodifica (pos. 317) solo con piattello diam. int. 13,5.

Les carters avant la modification seront fournis jusqu'à l'épuisement et seront ensuite remplacés par les nouveaux (complets de guides et sieges).

Sur le nouveaux carters il font monter soupapes, joints, coupelles et glicleurs maxi apres la modification. Les références des carburateurs changent à cause de la modification des glicleurs.

Toutes les autres pièces n'ont pas été changées (voir liste carburateurs aux pages 4/6 et 5/6).

Les arbres à cames ancien type sont fournis jusqu'à l'épuisement et seront ensuite remplacés par les nouveaux, qui sont interchangeables. Le joint soupape admission après la modification (pos. 317) peut être monté seulement avec coupelle diam. intérieur 13,5.

Prior to improvement crankcases are supplied until exhaustion and will be then replaced by the new ones. (complete with after improvement guides and seats).

On new crankcases it is necessary to assemble after improvement valves, gaskets, spring retainer and main jets.

The carburators change their ref. no., as main jets have been modified (all other components remain unchanged). See carburetor lists at pages 4/6 and 5/6.

The old type camshafts are supplied until exhaustion and will be then replaced by the interchangeable new ones. The after improvement intake valve gasket (pos. 317) can be assembled with spring retainer with internal diam. 13,5 only.

Das Kurbelgehäuse vor der Änderung wird bis zur Erschöpfung des Lagerbestandes geliefert.

Das neue Kurbelgehäuse wird mit Ventilführungen und Ventilsitzen geliefert.

Wird das neue Kurbelgehäuse eingesetzt sind die neuen Ventile, Dichtungen, Scheibe und Hauptdüse zu verwenden.

Bei dem Vergaser ändert sich die Ersatzteilnr., wenn die Hauptdüse modifiziert wird.

Alle anderen Teile bleiben unverändert. Siehe Liste der Vergaser Seite 4/6 und 5/6.

Die alte Nockenwelle wird bis zur Erschöpfung des Bestandes geliefert und wird dann durch die neue austauschbare ersetzt. Die Ventilschaftabdichtung nach der Änderung (N. 317) kann nur mit der Scheibe mit innerem Durchm. von 13,5 mm montiert werden.

La bancada antes de la modificación será suministrada hasta su agotamiento y puede sustituirse por la modificada (completa de guía y asiento).

Sobre la nueva bancada deben ser montados válvula, junta, platillo y surtido modificado.

El carburador cambia la referencia por la modificación del surtidor (todo el resto de componentes no varian) (ver tabla carburador en pag. 4/6 y 5/6).

El eje de levas viejo tipo seran suministrados hasta su agotamiento y puede ser sustituido por el nuevo intercambiable. Se puede montar la junta válvula admisión despues de la modification (pos. 317) solo con platillo diam. int. 13,5.

Attuazione da	IM 250 = 3722262
A partir de	IM 300 = 3751055
Starting from IM 350 = 3662256
Gültig ab	IM 359 = 3624497
Actualización desde	

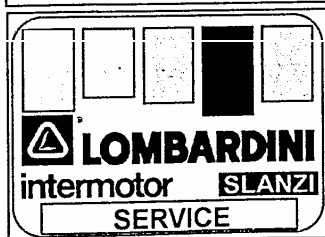

CIRCOLARE TECNICA
CIRCULAIRE TECHNIQUE
SERVICE LETTER
TECHNISCHES RUNDSCHREIBEN
CIRCULAR TECNICA

Compilazione	Sez. Sect. .22
<i>M. Primelli</i>	N.22005
Visto/approvazione	Data 15/03/96
<i>Marco Biondi</i>	
Modello 50723	m.t.m. ..6953

Antemodifica Avant la modification Prior to improvement Vor der Änderung Antes de la modificacion				Postmodifica Après la modification After improvement Nach der Änderung Después de la modificacion			
FIG.	MATR./REF./P.NO		Q.ty	FIG.	MATR./REF./P.NO		Q.ty
64	9685.126	147 FVBCR	1	64	9685.128	147 FVACR	1
65	9652.120	090 FVBCR	1	65	9652.122	147 FVACR	1
134	1510.436	147 E	1IM 250 (a)	134	1510.716	147 D A	1IM 250 (a)
"	1510.439	147 E	" (b)	"	1510.722	147 D A	" (b)
"	1510.442	147 E	" (c)	"	1510.726	147 N A	" (c)
"	1510.445	147 E	" (d)	"	1510.730	147 N A	" (d)
"	1510.437	155 E	1IM 300 (a)	"	1510.718	155 D A	1IM 300 (a)
"	1510.440	155 E	" (b)	"	1510.723	155 D A	" (b)
"	1510.443	155 E	" (c)	"	1510.727	155 D A	" (c)
"	1510.446	155 E	" (d)	"	1510.731	155 N A	" (d)
"	1510.438	158 E	1IM 350 (a)	"	1510.720	158 S A	1IM 350 (a)
"	1510.441	158 E	" (b)	"	1510.724	158 D A	" (b)
"	1510.444	158 E	" (c)	"	1510.728	158 D A	" (c)
"	1510.447	158 E	" (d)	"	1510.732	158 N A	" (d)
"	1510.490	169 E	1IM 359 (a)	"	1510.721	169 D A	1IM 359 (a)
"	1510.505	169 E	" (b)	"	1510.725	169 N A	" (b)
"	1510.504	169 E	" (c)	"	1510.729	169 N A	" (c)
"	1510.506	169 E	" (d)	"	1510.733	169 N A	" (d)
135	4845.028	090 FV CR	1	135	4845.028	090 FV CR	1
136	8000.168	147 SVBCR	1	136	8000.122	112 SVACR	1
137	8000.169	147 SVBCR	1	137	8000.121	112 SVACR	1
142	6400.029	090 FV C10	D. Ø 12,5	142	6400.029	090 FV C10	D. Ø 13,5
190	1011.268	147 E	1IM 250	190	3348.040	169 D I	1IM 250
"	1011.290	158 E	" 251	"			" 251
			" 252				" 252
			" 300				" 300
			" 301				" 301
			" 302				" 302
			" 350				" 350
			" 351				" 351
			" 352				" 352
			" 359				" 359
302	Vedi tabella carburatori pag. 4 e 5 Voir liste carburateur pages 4 et 5 See carburetor list, page 4 and 5 Siehe Vergaserliste Seite 4 - 5 Ver tabla carburador pag. 4 y 5			302	Vedi tabella carburatori pag. 4 e 5 Voir liste carburateur pages 4 et 5 See carburetor list, page 4 and 5 Siehe Vergaserliste Seite 4 - 5 Ver tabla carburador pag. 4 y 5		
317	4535.015	107 FVACR	1	317	4535.015	107 FVACR	1
318	4845.028	090 FVBCR	1	318	4845.203	158 FVACR	1

(a) standard
Standard
Standard
Standard
Standard

(c) per spia olio
Pour témoin huile
For oil warning light
Für Warnlampe-Ölmangel
Para espia aceite

(b) per avviamento elettrico
Pour démarrage électrique
For electrical starting
Für Elektro-Anlasser
Para arranque electrico

(d) per avviamento elettrico + spia olio
Pour démarrage électrique + témoin huile
For electrical starting + oil warning light
Für Elektro-Anlasser und Warnlampe-Ölmangel
para arranque electrico + espia aceite

Antemodifica
 Avant la modification
 Prior to improvement
 Vor der Änderung
 Antes de la modificacion

Postmodifica
 Après la modification
 After improvement
 Nach der Änderung
 Después de la modificacion



TABELLA CARBURATORI
LISTE CARBURATEURS
CARBURETOR LIST
VERGASERLISTE
LISTA CARBURADORES

Antemodifica/Avant la modification/Prior to improvement
Vor der Aenderung/Antes de la modificacion

Applicabilità Application Application Version Aplicabilidad	Motore Moteur Engine Motor Motor	Carburatore Carburateur Carburetor Vergaser Carburador	Tipo Type Type Type Tipo	Getto max. Gliceur max Main ject Hauptduse Surtider max	diam. diam. diam. Durchm diam.
per filtro aria a secco pour filtre à air à sec for dry air cleaner Für Trockenluft filter para filtro aire seco	IM 250	2151.237 1550	FVCA 22-17	4126.017 147	90
	IM 252				
	IM 300				
	IM 302				
	IM 350	2151.239 1580	FVCA 24-19	4126.018 158	92
	IM 352				
	IM 359	2151.236 1690	FVCA 26-21	4126.073 1690	103
per filtro aria a bagno d'olio pour filtre à air en bain d'huile for oil bath air cleaner Für Ölbadluft filter Para filtro aire en baño aceite	IM 250	2151.237 1550	FVCA 22-17	4126.017 147	90
	IM 252				
	IM 300				
	IM 302				
	IM 350	2151.239 1580	FVCA 24-19	4126.018 158	92
	IM 352				
	IM 359				
per filtro aria a secco e starter a distanza Pour filtre à air à sec et démarrage à distance For dry air cleaner and remote starter Trockenluft filter und Betätigung des Chokes mit Bowdenzug Para filtro aire seco y estarter a distancia	IM 250	2151.199 1470	FVCA 22-17	4126.017 147	90
	IM 252				
	IM 300				
	IM 302				
	IM 350	2151.200 1580	FVCA 24-19	4126.018 158	92
	IM 352				
	IM 359	- -		- -	
per filtro aria a bagno d'olio e starter a distanza Pour filtre à air en bain d'huile et démarrage à distance For oil bath air cleaner and remote starter Ölbadluft filter und Betätigung des Chokes mit Bowdenzug para filtro aire en baño de aceite y estarter a distancia	IM 250	2151.199 1470	FVCA 22-17	4126.017 147	90
	IM 252				
	IM 300				
	IM 302				
	IM 350	2151.200 1580	FVCA 24-19	4126.018 158	92
	IM 352				
	IM 359				
per filtro aria a secco e alimentazione G.P.L. pour filtre à air à sec et alimentation G.P.L. for dry air cleaner and L.P.G. feeding Für Trockenluft filter und Gasbetrieb Para filtro aire seco y alimentación G.P.L	IM 250	2151.228 1470	FVCA 22-17	4126.017 147	90
	IM 252				
	IM 300				
	IM 302				
	IM 350	2151.229 1580	FVCA 24-19	4126.018 158	92
	IM 352				
	IM 359	2151.245 1580	FVCA 26-21	4126.073 1690	103
per filtro aria a bagno d'olio e aliment. G.P.L. pour filtre à air en bain d'huile et alimentation G.P.L. for oil bath air cleaner and L.P.G. feeding Für Ölbadluft filter und Gasbetrieb para filtro de aire en baño de aceitey alimentación G.P.L.	IM 250	2151.228 1470	FVCA 22-17	4126.017 147	90
	IM 252				
	IM 300				
	IM 302				
	IM 350	2151.229 1580	FVCA 24-19	4126.018 158	92
	IM 352				
	IM 359				

TABELLA CARBURATORI
LISTE CARBURATEURS
CARBURETOR LIST
VERGASERLISTE
LISTA CARBURADORES

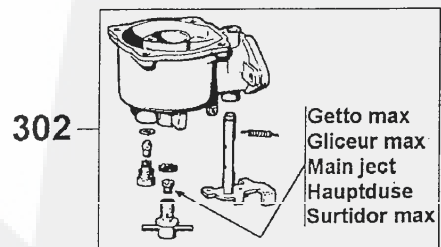
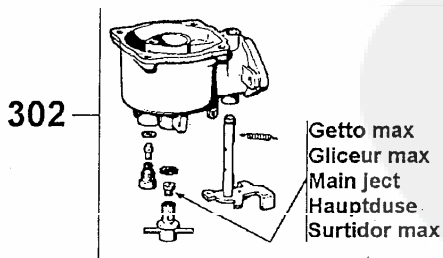
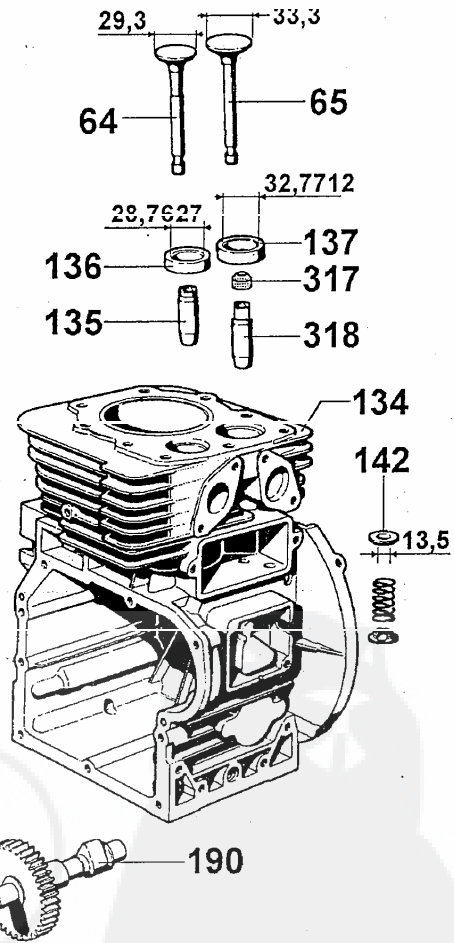
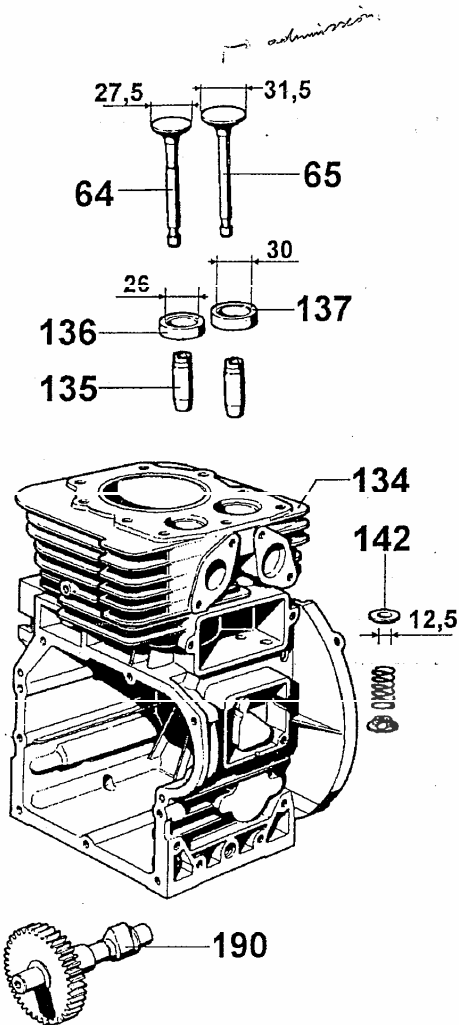
Postmodifica/Après la modification/After improvement
Nach der Aenderung/Despuès de la modificacion

Applicabilità Application Application Version Aplicabilidad	Motore Moteur Engine Motor MOTOR	Carburatore Carburateur Carburetor Vergaser Carburador	Tipo Type Type Typ tipo	Getto max. Gliceur max Main ject Hauptduse surtidor max	diam. diam. diam. Durch diam.
per filtro aria a secco pour filtre à air à sec for dry air cleaner Für Trockenluft filter para filtro aire seco	IM 250	2151.246 147	FVCA 22-17	4126.077 147	94
	IM 300				
	IM 350				
	IM 252	2151.247 155	FVCA 22-17	4126.075 169	98
per filtro aria a bagno d'olio pour filtre à air en bain d'huile for oil bath air cleaner Für Ölbadluft filter Para filtro aire en baño aceite	IM 302				
	IM 352	2151.250 159	FVCA 24-19	4126.074 159	101
	IM 359	2151.249 169	FVCA 24-19	4126.075 169	98
	IM 250	2151.237 1550	FVCA 22-17	4126.017 147	90
per filtro aria a bagno d'olio pour filtre à air en bain d'huile for oil bath air cleaner Für Ölbadluft filter Para filtro aire en baño aceite	IM 300				
	IM 350				
	IM 252	2151.246 147	FVCA 22-17	4126.077 147	94
	IM 302				
per filtro aria a secco e starter a distanza pour filtre à air à sec et démarrage à distance For dry air cleaner and remote starter Trockenluft filter und Betätigung des Chokes mit Bowdenzug Para filtro aire seco y estarter a distancia	IM 352	2151.248 1690	FVCA 24-19	4126.077 147	94
	IM 359				
	IM 250	2151.251 1470	FVCA 22-17	4126.077 147	94
	IM 300				
per filtro aria a bagno d'olio e starter a distanza pour filtre à air en bain d'huile et démarrage à distance For oil bath air cleaner and remote starter Ölbadluft filter und Betätigung des Chokes mit Bowdenzug para filtro aire en baño de aceite y estarter a distancia	IM 350				
	IM 252	2151.252 1570	FVCA 22-17	4126.075 169	98
	IM 302				
	IM 352	2151.255 1590	FVCA 24-19	4126.074 159	101
per filtro aria a secco e alimentazione G.P.L. pour filtre à air à sec et alimentation G.P.L. for dry air cleaner and L.P.G. feeding Für Trockenluft filter und Gasbetrieß Para filtro aire seco y alimentación G.P.L	IM 359	2151.254 1690	FVCA 24-19	4126.075 169	98
	IM 250	2151.199 1470	FVCA 22-17	4126.017 147	90
	IM 300				
	IM 350				
per filtro aria a bagno d'olio e starter a distanza pour filtre à air en bain d'huile et alimentation G.P.L. for oil bath air cleaner and remote starter Ölbadluft filter und Betätigung des Chokes mit Bowdenzug para filtro aire en baño de aceite y estarter a distancia	IM 252	2151.251 1470	FVCA 22-17	4126.077 147	94
	IM 302				
	IM 352	2151.253 1690	FVCA 24-19	4126.075 169	98
	IM 359				
per filtro aria a secco e alimentazione G.P.L. pour filtre à air à sec et alimentation G.P.L. for dry air cleaner and L.P.G. feeding Für Trockenluft filter und Gasbetrieß Para filtro aire seco y alimentación G.P.L	IM 250	2151.256 1470	FVCA 22-17	4126.077 147	94
	IM 300				
	IM 350				
	IM 252	2151.257 1570	FVCA 22-17	4126.075 169	98
per filtro aria a bagno d'olio e aliment. G.P.L. pour filtre à air en bain d'huile et alimentation G.P.L. for oil bath air cleaner and L.P.G. feeding Für Ölbadluft filter und Gasbetrieß para filtro de aire en baño de aceitey alimentación G.P.L	IM 302				
	IM 352	2151.260 1590	FVCA 24-19	4126.074 159	101
	IM 359	2151.259 1690	FVCA 24-19	4126.075 169	98
	IM 250	2151.228 1470	FVCA 22-17	4126.017 147	90
per filtro aria a bagno d'olio e aliment. G.P.L. pour filtre à air en bain d'huile et alimentation G.P.L. for oil bath air cleaner and L.P.G. feeding Für Ölbadluft filter und Gasbetrieß para filtro de aire en baño de aceitey alimentación G.P.L	IM 300				
	IM 350				
	IM 252	2151.256 1470	FVCA 22-17	4126.077 147	94
	IM 302				
per filtro aria a bagno d'olio e aliment. G.P.L. pour filtre à air en bain d'huile et alimentation G.P.L. for oil bath air cleaner and L.P.G. feeding Für Ölbadluft filter und Gasbetrieß para filtro de aire en baño de aceitey alimentación G.P.L	IM 352	2151.258 1690	FVCA 24-19	4126.077 147	94
	IM 359				

Gruppo motori		Tipo	
Groupe moteurs		Type	
Engine group	22	Type	1IM 250 - 300 - 350 - 359
Motorgruppe		Typ	1IM 359 CEE
Grupo motores		Tipo	

- Inserito lamierino pescaolio : Migliorie funzionali.
- Introduction cuiller de barbotage : Améliorations fonctionnelles.
- Introduction of splash feeding blade : Functional improvements.
- Neuer Ölfinger : Betriebsverbesserung.
- Nueva chapa batidora de aceite : Mejorias funcionales.

Antemodifica Avant la modification Prior to improvement Vor der Änderung Antes de la modificación	Postmodifica Après la modification After improvement Nach der Änderung Después de la modificación
---	---

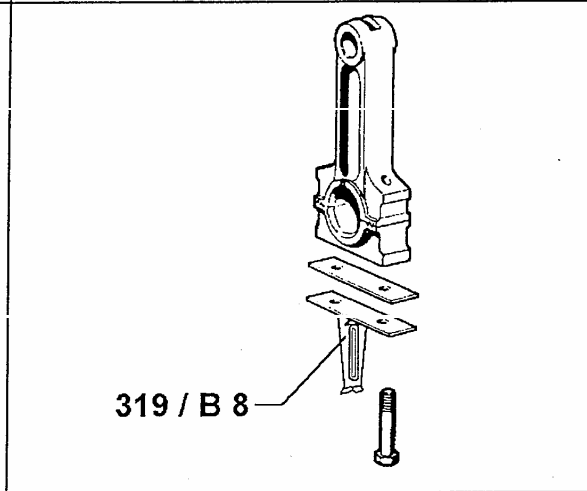
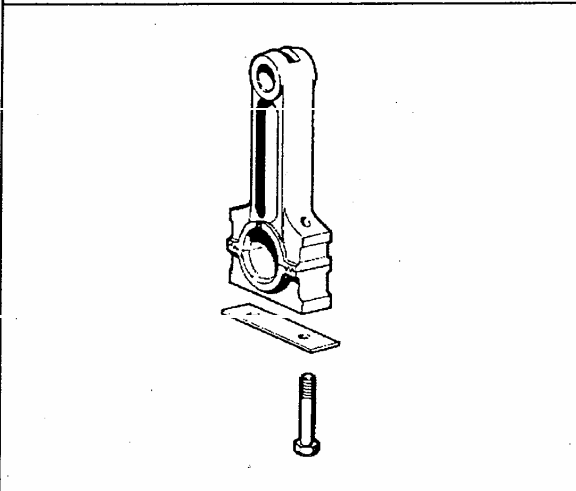

1IM 250 - 300 - 350 - 359

FIG.	MATR./REF./P.NO	Q.ty
319	5168.055 1580 S A	1

1IM 359 CEE

FIG.	MATR./REF./P.NO	Q.ty
B 8	5168.055 1580 S A	1

Attuazione da
A partir de
Starting from 3554131
Gültig ab
Actualización desde

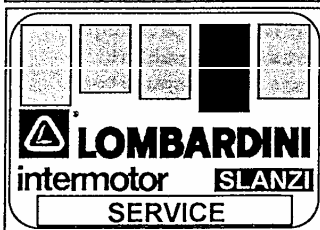

CIRCOLARE TECNICA
CIRCULAIRE TECHNIQUE
SERVICE LETTER
TECHNISCHES RUNDSCHREIBEN
CIRCULAR TECNICA

Compilazione <i>[Signature]</i>	Sez.Sect. .22
	N.22007
Visto/approvazione <i>[Signature]</i>	Data 15/03/96
Modello 50723	m.t.m. ..6960

Pubblicazioni tecniche interessate alla modifica:
 Publications techniques concernant la modification:
 Improvement applies to the following technical publications:
 Von der Änderung betroffene technische Veröffentlichungen:
 Publicaciones técnicas referidas a la modificación:

Tavola ricambi Tabl. Pièces Dét. Spare Parts Table Ersatzteiltafel Tabla Repuestos	Catalogo accessori Catalogue Accessories Accessoires Catalogue Zubehörkatalog Catalogo Accesorios	Catalogo Kit Ricambi Catalogue Kit-Rechang. Sp. Parts-Kit Catalogue Ersatzteilgruppenkat. Catalogo Kit-Repuestos
1.5302.002 1.5302.377		



● ○ 147-1471-11
Autoavvolgente compl.

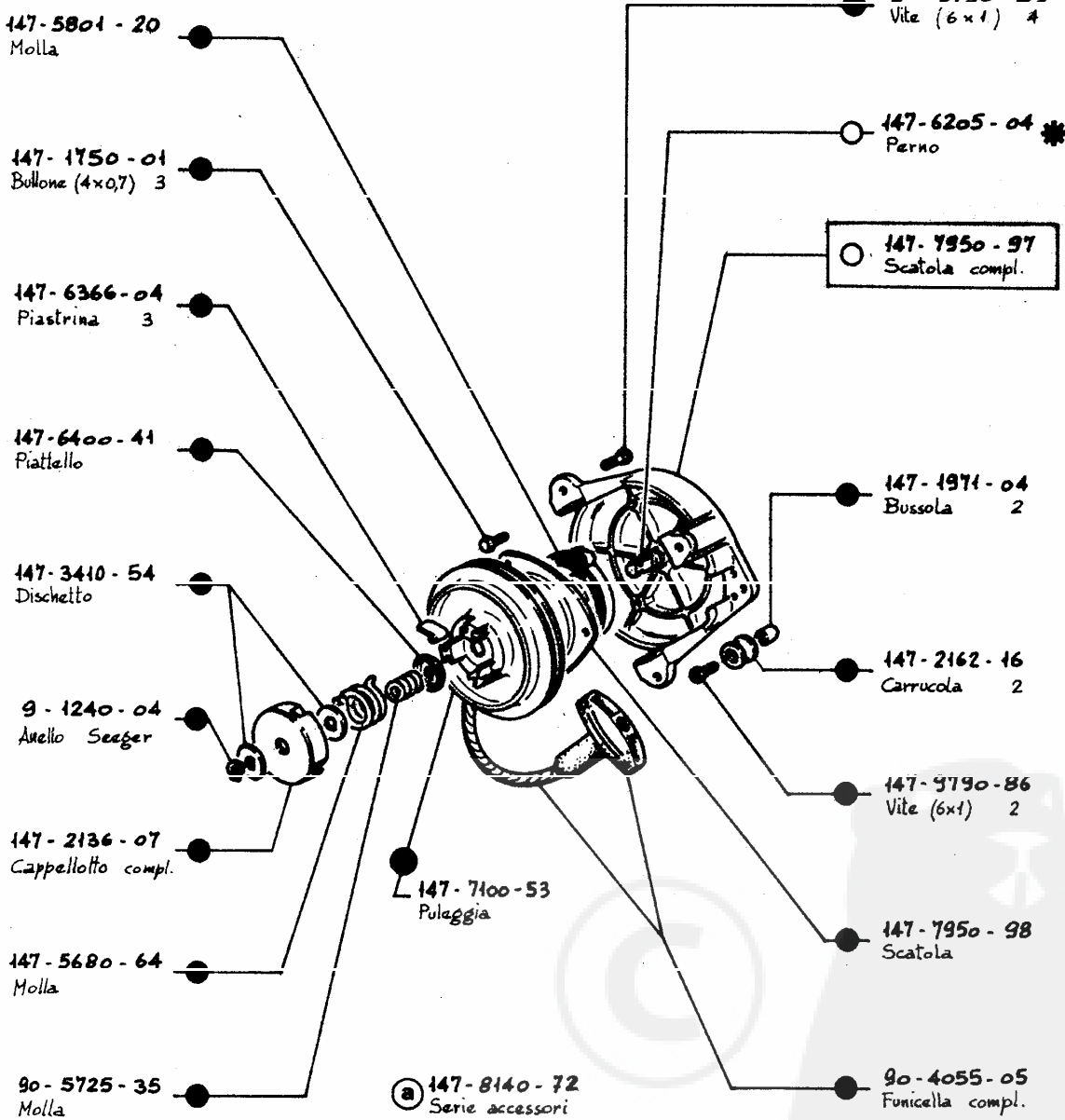

NOTE REMARQUES REMARKS				Vedi tavola ② Voir table G 11 See table
MOTORE MOTEUR ENGINE	SERIE IM	COMPLESSIVO GROUPE ASSEMBLY		NON FORNITO SGIOLTO * NON LIVRE SEPAREMENT NOT SUPPLIED SEPARATELY
AVVIATORE AUTOAVVOLGENTE LANCEUR A CABLE REWIND STARTER			K.9993-77	TAVOLA TABLE C8
				DATA DATE 7-83

Engine: 11M 350 Drawing: M

M
11M

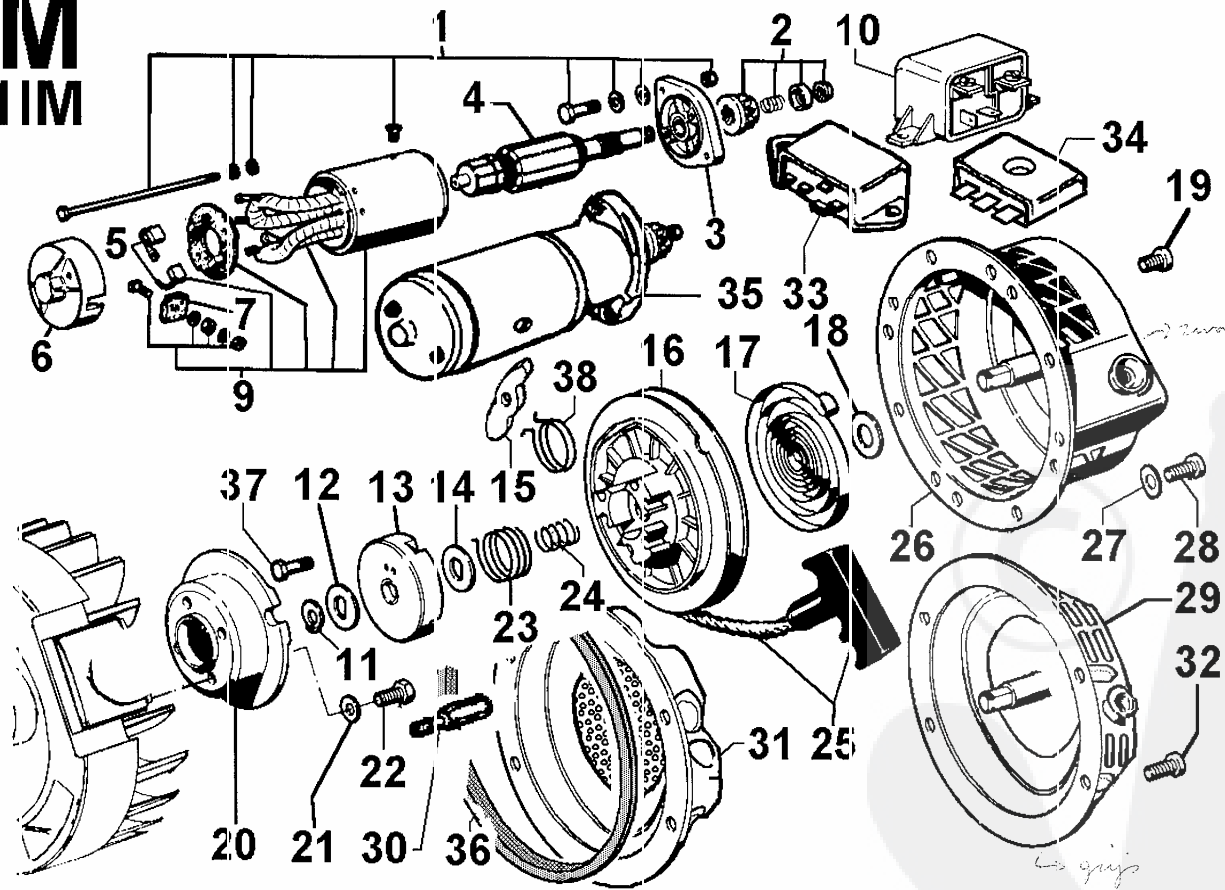



Group: 11M
 Engine: 11M 350 Drawing: M

STARTING

POS.	CODE	DESCRIPTION	Qty
1	8140.097	spare part set	1
2	6456.009	pinion gear	1
3	«-----»	plate	0
5	8310.043	brush set	1
6	8815.063	support	1
7	6617.009	brush holder	1
9	9599.045	starting motor spare part	1
10	5041.019	relay	1
11	1165.006	circlip diam. 7	1
12	3410.054	spacer	1
13	2136.022	cap	1
14	3410.054	spacer	1
15	6366.004	plate	1
16	7100.244	pulley	1
17	5801.179	rewind spring	1
18	3430.101	spacer	1
19	9790.037	screw M 6 X 8	2
20	6961.014	pulley	1
21	7555.004	washer diam. 6	4
22	1760.005	bolt M 6 X 1 X 16	4
23	5680.064	spring	1
24	5725.041	spring	1
25	4055.005	rope starting	1
26	1471.069	REWIND STARTING motorcultivator	1
26	1471.085	REWIND STARTING	1
27	7625.008	washer diam. 6.4	4
28	9790.039	screw M 6 X 12	2
33	7362.255	voltage regul.12 V 12 A	1
34	7362.232	light.alt.regul.-5 contacts for alt. 3 fili	1
35	5840.119	starting motor	1
29	1479.053	starter complete -> also new or genuine carbon brush with plastic case	
	1479.053		

Additional Info - Engine: 11M 350 Drawing: M

STARTING

Pos.	Old part	Serv.Lett.	Notes	S.No/Date
M 3	6360.043	747	- fitted until shown engine s.no	1027875
	8900.154	752	- fitted until shown date	09.1988
M 33	6607.015	757	-	1096585
	7362.225	764	-	05.1990
M 35	5840.058	747	-	1027875

