

LGA 340 = boezigie
RCAZYC!



intermotor

LGA 280 - 340

by LOMBARDINI

TAVOLA RICAMBI
TABLEAU PIECES DETACHEES
SPARE PARTS TABLE
ERSATZTEILTAFEL
TABLA DE REPUESTOS
TÁBUA PEÇAS DE TROCA

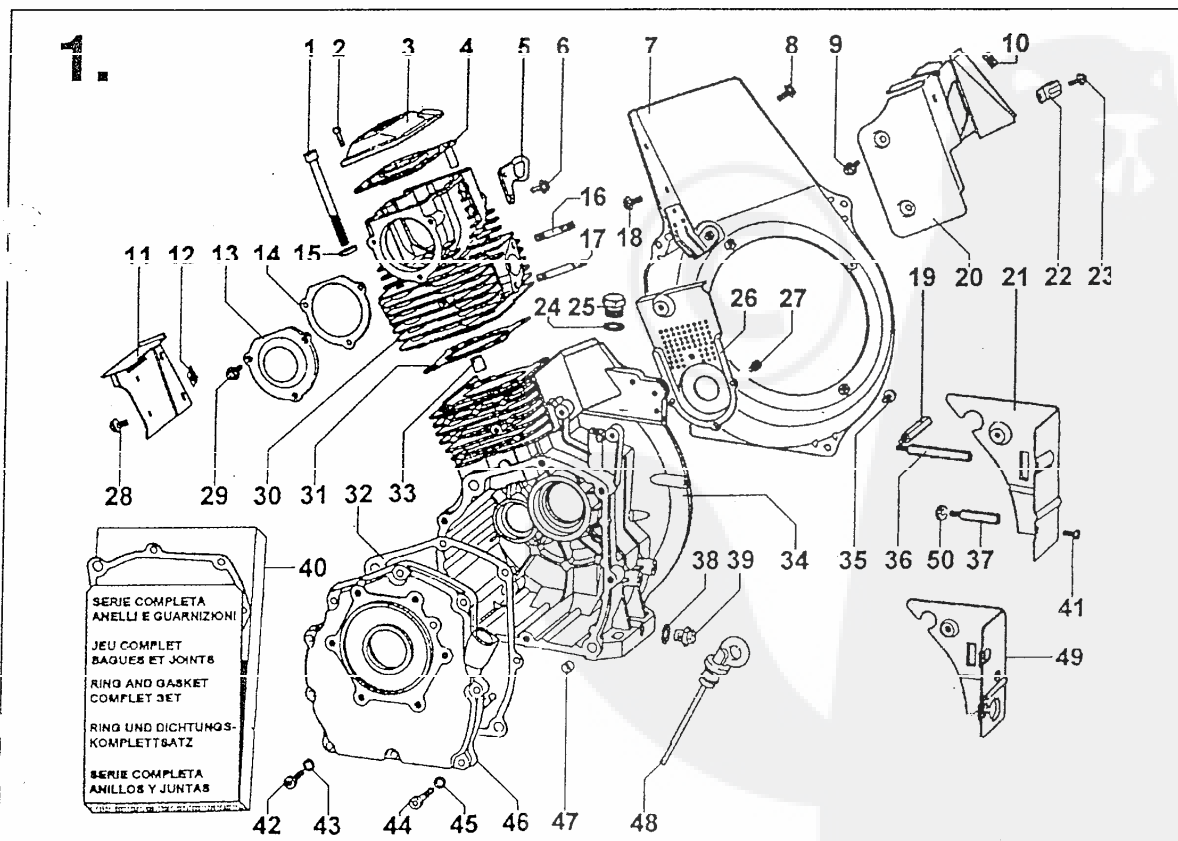
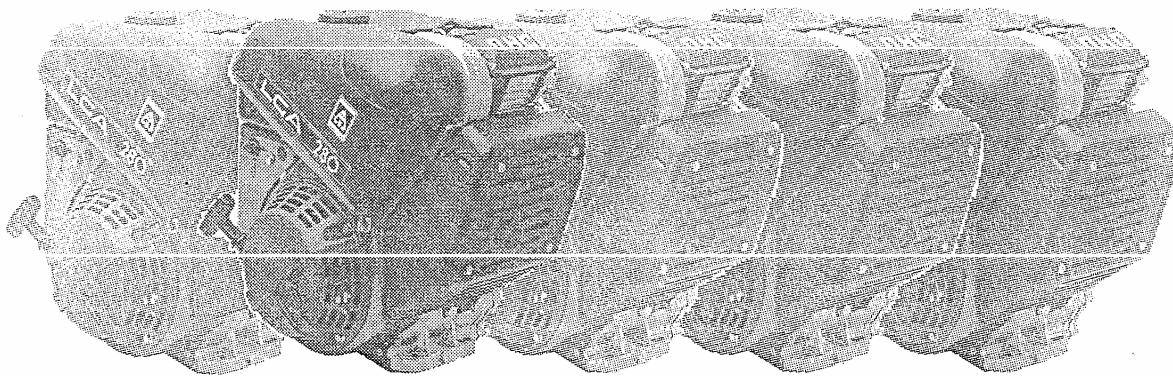

2.

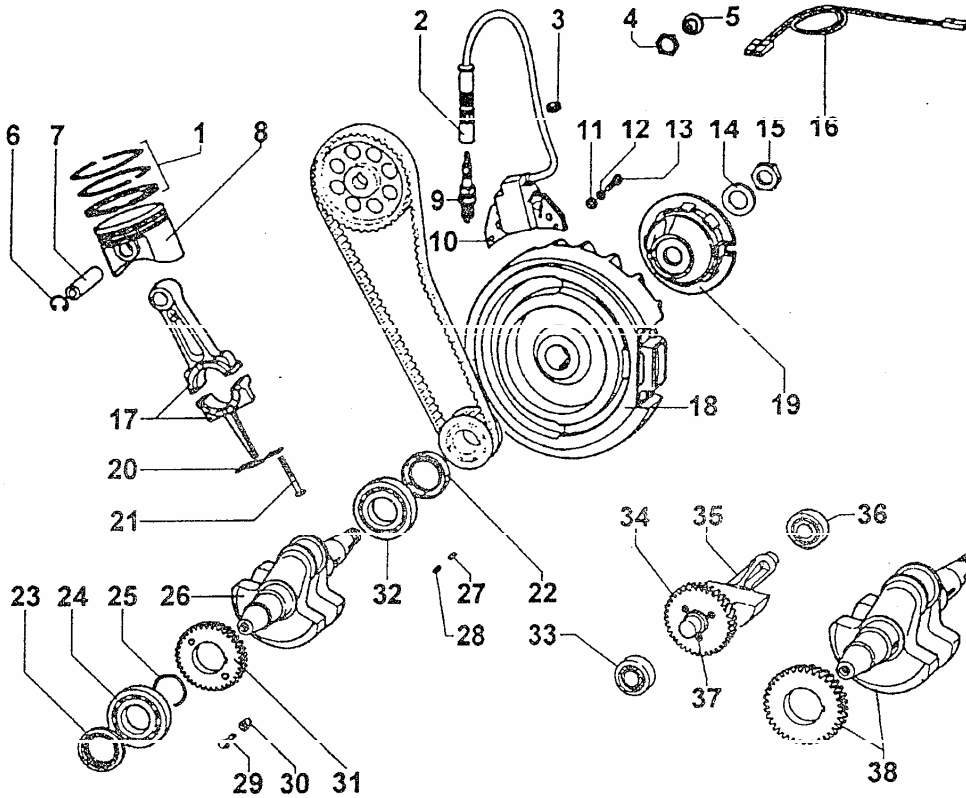

 intermotor **LGA 280 - 340**

3.

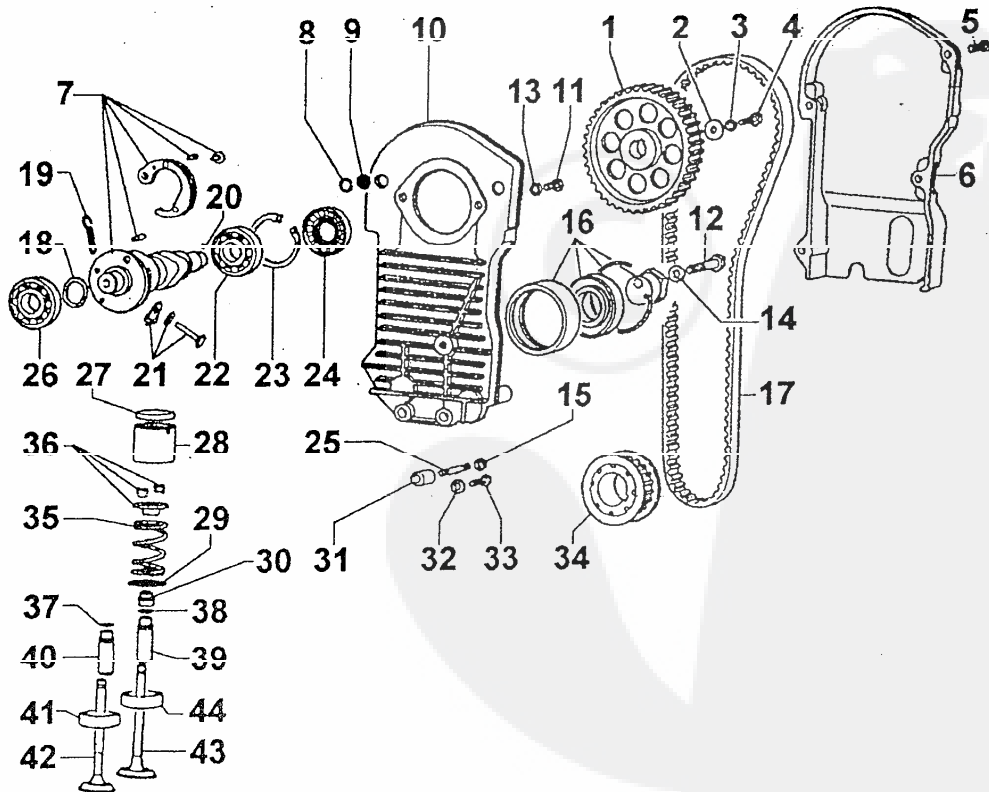

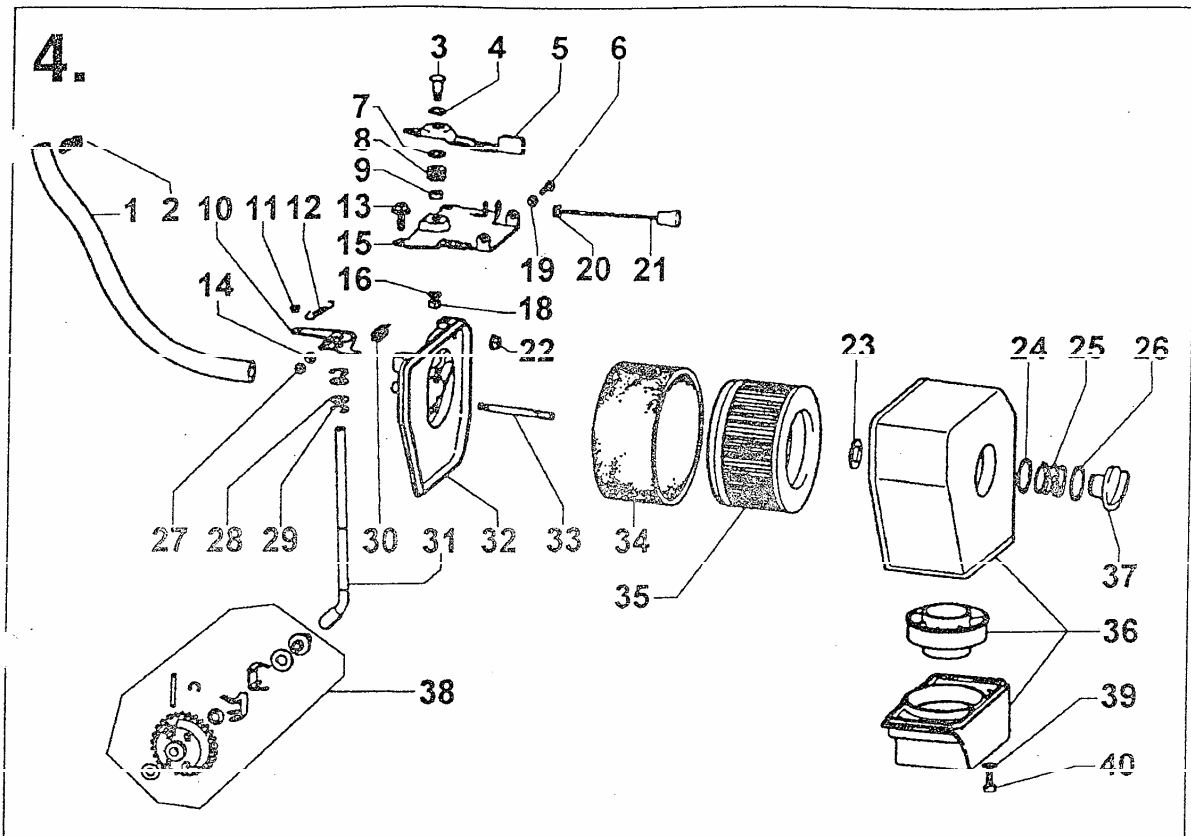

 intermotor **LGA 280 - 340**

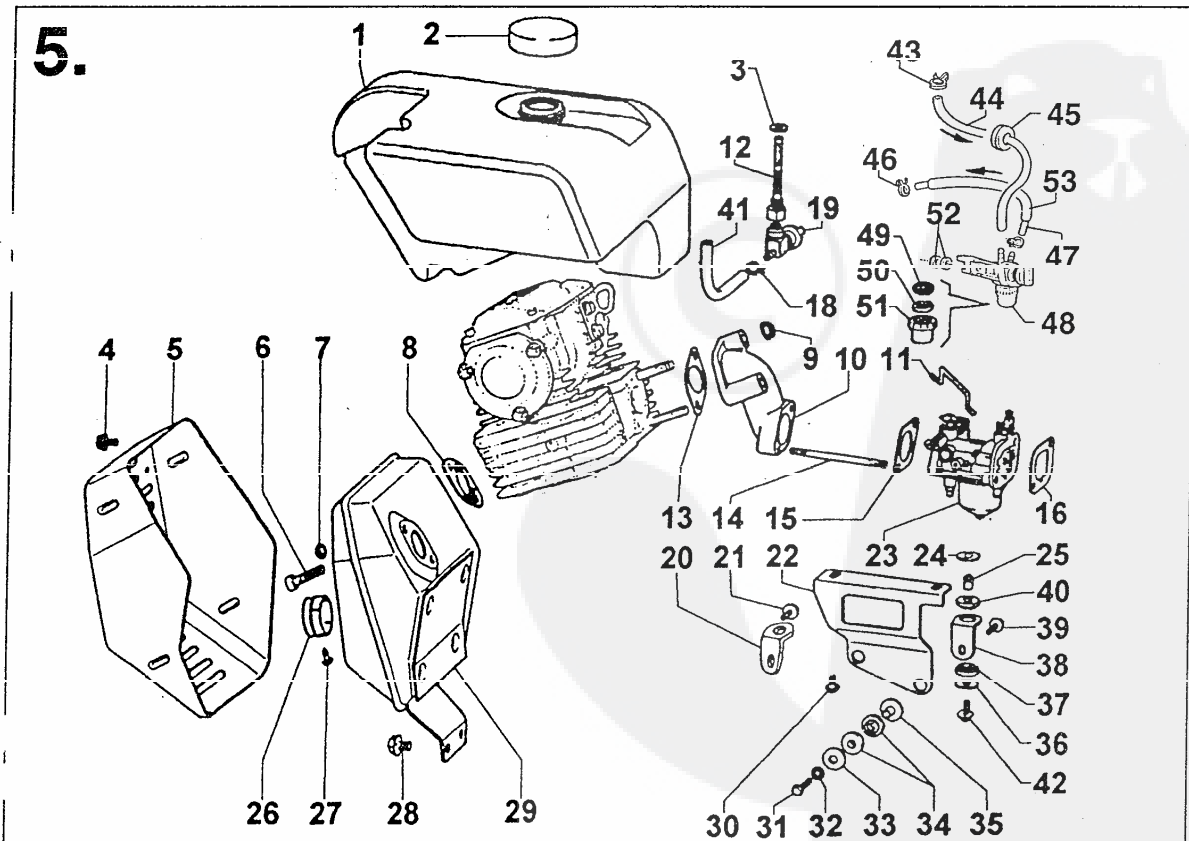

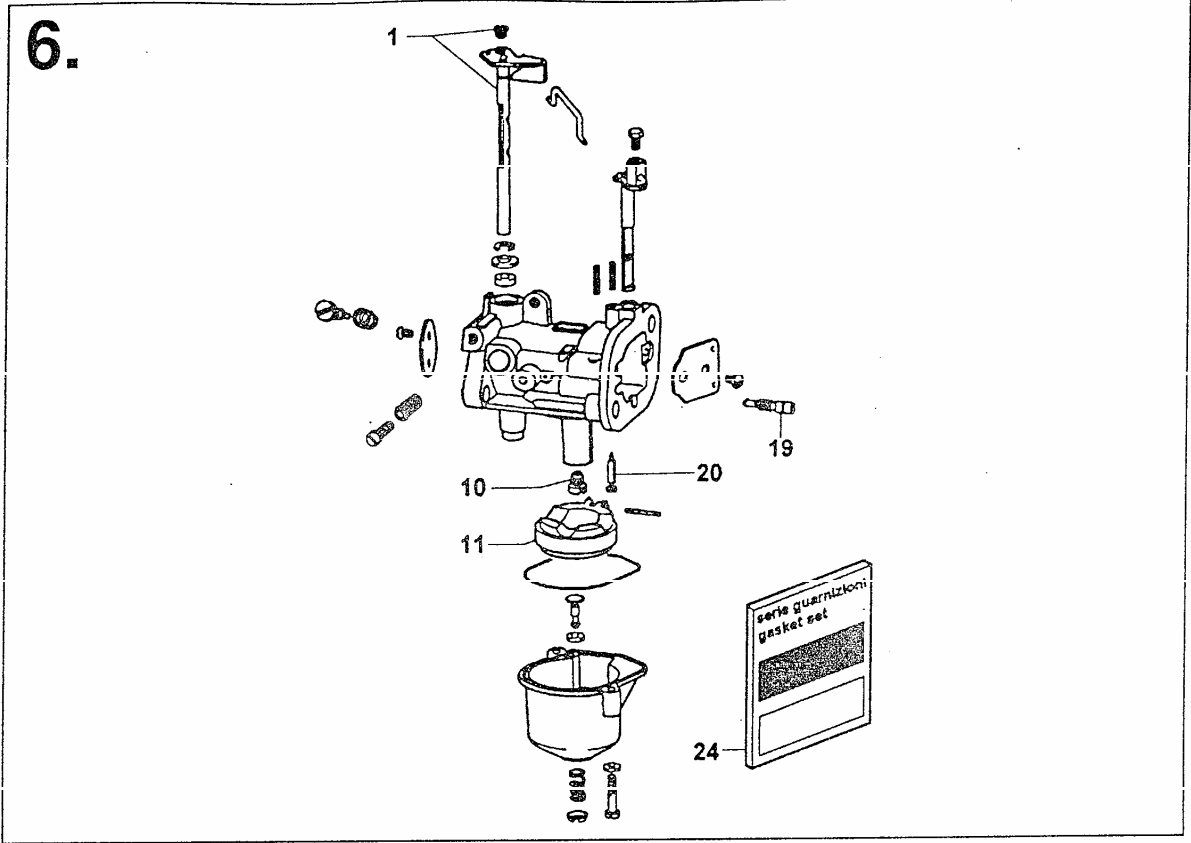

intermotor LGA 280 - 340

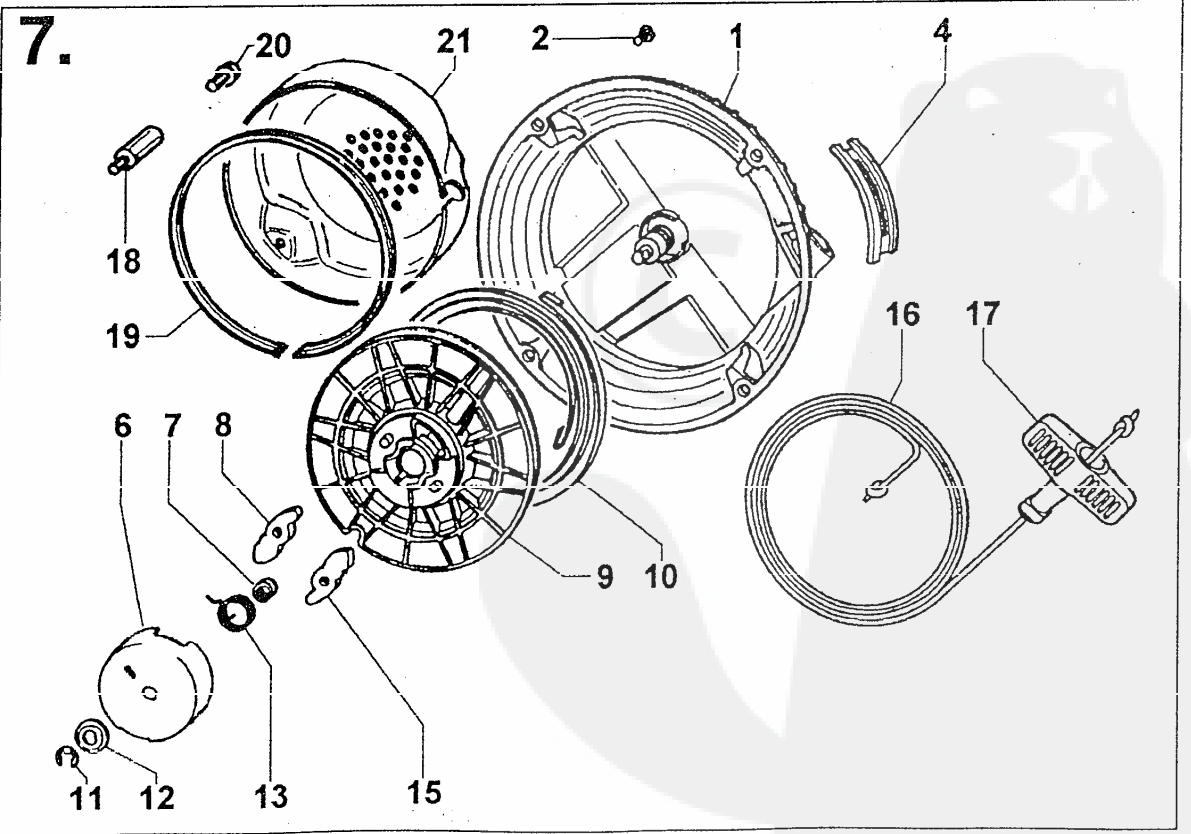

8.

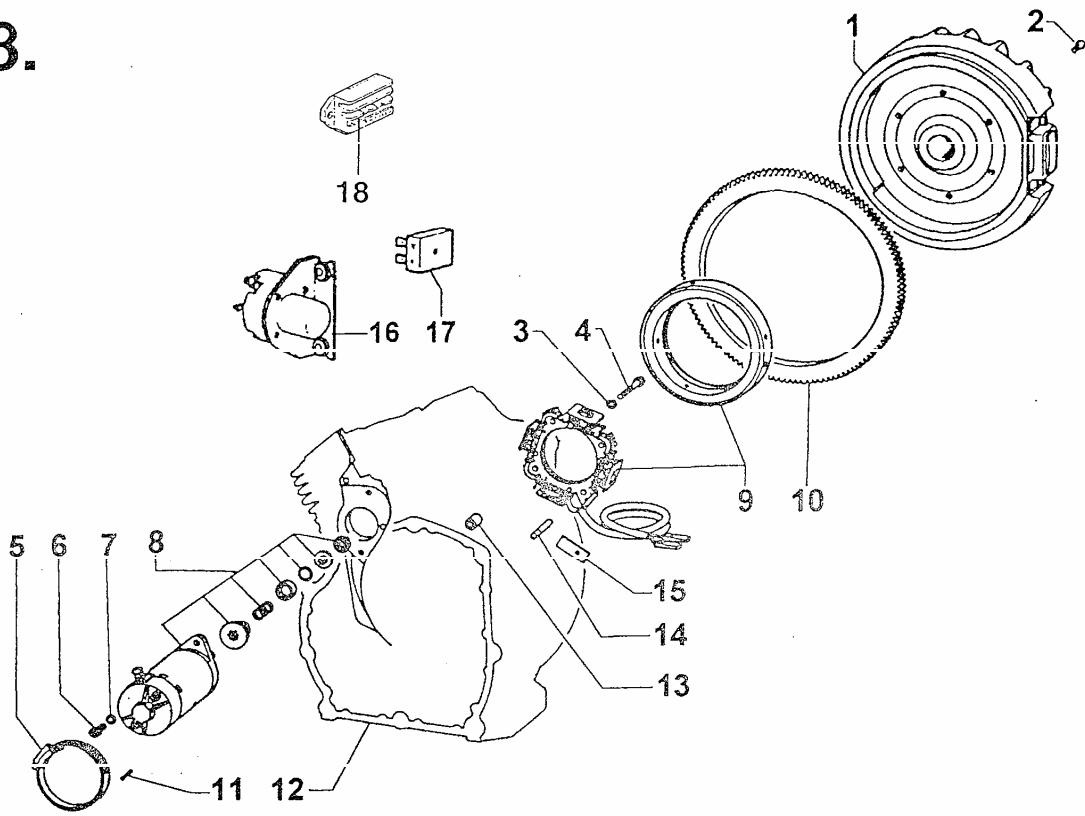

 intermotor **LGA 280 - 340**

9.

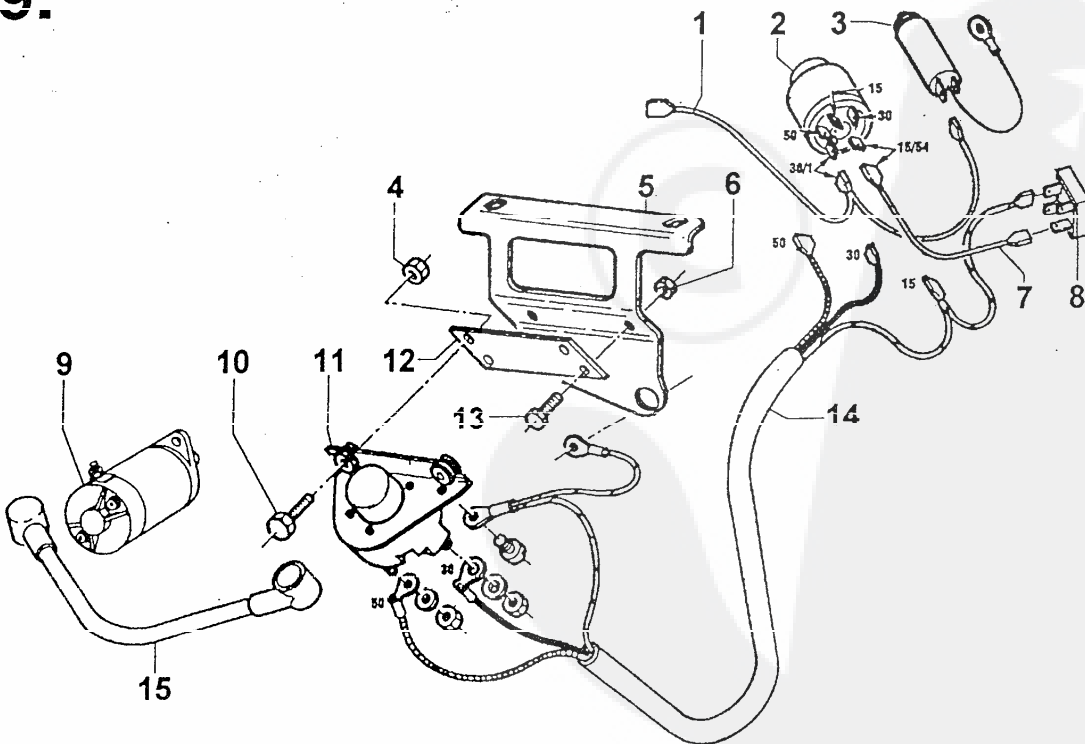

10.

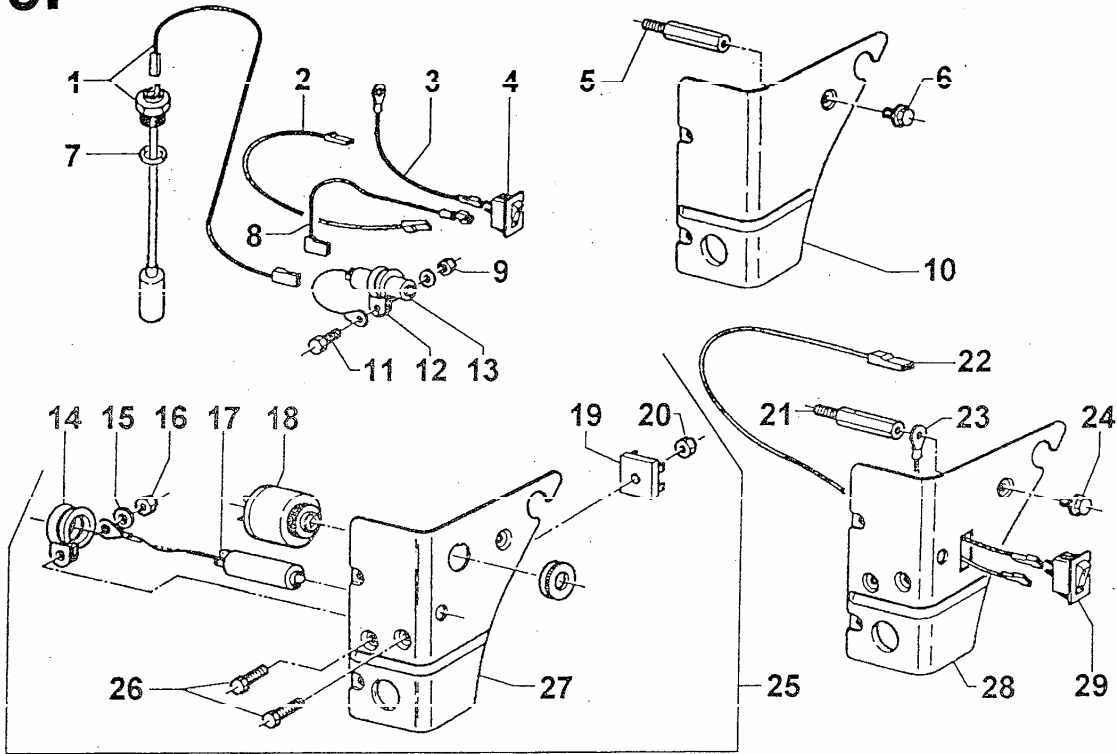

 **intermotor LGA 280 - 340**



Particolari per motori standard. Per applicazioni speciali consultare il Catalogo presso i Centri Assistenza e Ricambi. Descrizioni e illustrazioni non impegnative.

Parts for standard engines. For special applications see Master Catalog at Service Centers. Descriptions and characteristics subject to modifications.

Pièces pour moteurs standard. Pour les applications spéciales veuillez consulter le Catalogue auprès des Agents Service. Descriptions et illustrations peuvent être modifiées.

Teile für Standard-Motoren. Für Sonderausführungen siehe Ersatzteilkatalog bei den Service Werkstätten. Änderungen vorbehalten.

Repuestos para motores standard. Para aplicaciones especiales véase Catálogo en las estaciones Servicio. Instrucciones y ilustraciones pueden ser modificadas.

 **LOMBARDINI**

42100 Reggio Emilia, Italy
Via Cav. del Lavoro Adelmo Lombardini, 2
Casella Postale 1074
Tel. (0522) 3891 - Telex: 530003 Motlom I
Telegr.: Lombarmotor - Telefax (0522) 389465

 ENTE COMPILATORE DICO/RICA <i>file</i>	COD. LIBRO 1-5302-483	MODELLO N° 50730	DATA EMISSIONE 06-96	REVISIONE 02	DATA 02-02-98	VISTO <i>[Signature]</i>
---	--------------------------	---------------------	-------------------------	--------------	------------------	-----------------------------

vedi TAVOLA RIC./see SPARE P.TABLE/voir TABLEAU P.DETACH. 1.5302.483

 Novembre/November/Novembre 1997

MOTORI/ENGINES/MOTEURS Gr. 25

LGA 280
 LGA 340

Vedi/See/Voir

Libretto Uso e Man./Use-Maint.booklet/Livret Emploi-Entret. 5302.481 1
 Libretto Service/Service directory/Reseau S.A.V. 7968.002 1

Serie guarnizioni/Gasket set/Jeu de joints LGA 280 8180.195 240
 " " " " LGA 340 8180.200 239

 Descrizioni non impegnative/Subject to modifications/Modifications réservées
 TECO/ATL/Assistenza Tecnica Lombardini/Ottobre 1996

Riquadro		BASAMENTO/TESTA/PORTINA DISTRIBUZIONE/LAMIERATI RAFFREDDAMENTO
Drawing	1	CRANKCASE/CYLINDER HEAD/CASE COVER/COOLING PANELS
Dessin		CARTER MOTEUR/CULASSE/CARTER DISTRIBUTION/TOLES DE REFROIDISSEMENT
Riquadro		BIELLA E PISTONE/VOLANO/ALBERO A GOMITO/ACCENSIONE
Drawing	2	CONNECTING ROD/PISTON SET/FLYWHEEL/CRANKSHAFT/IGNITION
Dessin		BIELLE ET PISTON/VOLANT/VILEBREQUIN/ALLUMAGE
Riquadro		DISTRIBUZIONE/ALBERO A CAMME/VALVOLE
Drawing	3	TIMING/CAMSHAFT/VALVES
Dessin		DISTRIBUTION/ARBRE A CAMMES/SOUPAPES
Riquadro		COMANDI/REGOLATORE DI GIRI/FILTRO ARIA
Drawing	4	CONTROL/SPEED GOVERNOR/AIR FILTER
Dessin		COMMANDES/REGULATEUR DE VITESSE/FILTRE A' AIR
Riquadro		SERBATOIO/MARMITTA SCARICO/CARBURATORE
Drawing	5	FUEL TANK/EXHAUST MUFFLER/CARBURETOR
Dessin		RESERVOIR/POT D'ECHAPPEMENT/CARBURATEUR
Riquadro		RICAMBI CARBURATORE
Drawing	6	CARBURETOR SPARE PARTS
Dessin		RECHANGES CARBURATEUR
Riquadro		AVVIATORE AUTOAVVOLGENTE
Drawing	7	REWIND STARTER
Dessin		DEMARREUR A' LANCEUR AUTO-ENROULER
Riquadro		AVVIAMENTO ELETTRICO/QUADRETTO
Drawings	8/9/10	ELECTRICAL STARTING/PANEL (optional)
Dessins		DEMARRAGE/TABLEAU ELECTRIQUE

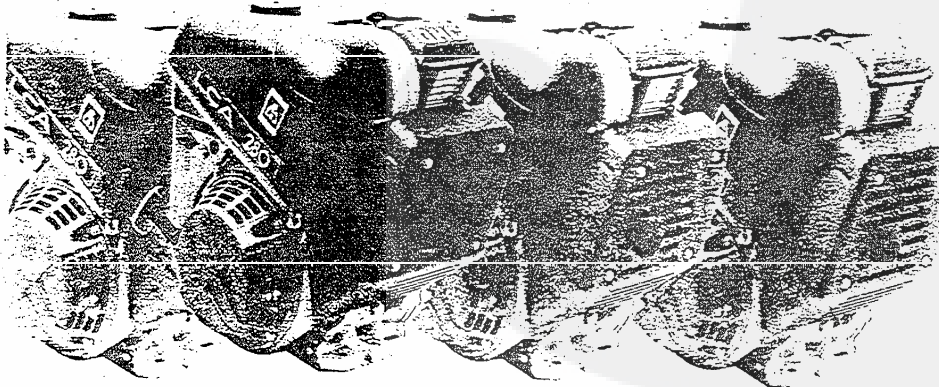

 LGA 280 - LGA 340 vedi Tavola Ric./see Parts Table 1.5302.483		LGA 280	LGA 340
Pos.	Matricola/Part No.	Note/Remarks	
1.44	9730.032 9	vite/screw	2 2
1.45	7645.006 9	rondella/washer	2 2
1.46	6645.554 240	portina distrib./timing cover	1 1
1.47	1970.419 240	bussola/sleeve	2 2
1.48	1400.282 240	asta livello/dipstick	1 1
1.49	ex novo ... -> 5981.083 239	I -> da/from s.No. 7500673 -> CT 25001 -> lamiera/panel	1 1
1.50	ex novo ... -> 7645.008 240	A -> da/from s.No. 7500673 -> CT 25001 -> rondella/washer	1 1
2.01	8211.236 240	serie segmenti/ring set std.	1 -
	8211.237 240	serie segmenti/ring set +0,50	1 -
	8211.238 240	serie segmenti/ring set +1,00	1 -
	8211.245 239	serie segmenti/ring set std.	- 1
	8211.246 239	serie segmenti/ring set +0,50	- 1
	8211.247 239	serie segmenti/ring set +1,00	- 1
2.02	2145.063 240	cappuccio/cap	1 1
2.03	5830.169 240	passafilo/wire-sleeve	1 1
2.04	3300.230 240	B -> fino/until No.7500672 -> CT 25001 ->	v v
2.05	7195.132 240	B -> fino/until No.7500672 -> CT 25001 ->	v v
2.06	1160.059 240	anello seeger/circlip	2 2
2.07	8480.097 240	spinotto/piston pin	1 1
2.08	=6501.408 240	PISTONE COMPL./PISTON ASS.Y std.	1 -
	=6501.409 240	PISTONE COMPL./PISTON ASS.Y +0,50	1 -
	=6501.410 240	PISTONE COMPL./PISTON ASS.Y +1,00	1 -
	=6501.500 239	PISTONE COMPL./PISTON ASS.Y std.	- 1
	=6501.501 239	PISTONE COMPL./PISTON ASS.Y +0,50	- 1
	=6501.502 239	PISTONE COMPL./PISTON ASS.Y +1,00 (Pos. 2.01-2.06-2.07-2.08)	- 1
2.09	ex 2100.079 - - - - -	sostituito da/superseded by - - - - ->	v v
	-> 2100.067 112	I candela/spark plug	1 1
2.10	1570.055 240	bobina/coll	1 1
2.11	7625.008 9	rondella/washer	2 2
2.12	7645.008 240	rondella/washer	2 2
2.13	9732.078 9	vite/screw	2 2
2.14	7625.284 240	rondella/washer	1 1
2.15	3260.129 240	dado/nut	1 1
2.16	2185.920 240	cavetto/wire	1 1
2.17	1526.185 240	biella/connbecting rod std.	1 1
	1526.190 240	biella/connbecting rod +0,25	1 1
	1526.191 240	biella/connbecting rod -0,50	1 1
2.18	9881.193 240	volano/std. flywheel	1 1
2.19	6961.109 240	puleggia/pulley	1 1
2.20	5168.064 240	lamierino/safety plate	1 1
2.21	1760.088 9	bullone/bolt	2 2
2.22	1213.355 240	anello tenuta/seal ring 30X40X7	1 1
2.23	1213.355 240	anello tenuta/seal ring 30X40X7	1 1
2.24	3001.070 9	cuscinetto/ball bearing	1 1
2.25	1301.333 240	anello elast./lockwasher	1 1
2.26	=1050.949 240	ALBERO GOMITO/CRANKSHAFT (Pos. 2.26-2.27-2.28-2.29-2.30- 2-31)	1 1
2.27	2200.022 240	chiavetta/key	1 1
2.28	2200.022 240	chiavotta/key	1 1
Motore/Engine		LGA 280	Versione/Version standard
" " " "		LGA 340	" " " "

 LGA 280 - LGA 340 vedi Tavola Ric./see Parts Table 1.5302.483			LGA 280	LGA 340
Pos.	Matricola/Part No.	Note/Remarks		
2.29	vedi/sec pos. 2.26	2	2
2.30	vedi/see pos. 2.26	2	2
2.31	vedi/see pos. 2.26	1	1
2.32	3001.070 9	cuscinetto/ball bearing	1	1
2.33	3001.088 239	cuscinetto/ball bearing	-	1
2.34	4936.251 239	ingranaggio alb.contrapp./gear	-	1
2.35	2537.048 239	contrappeso/counterweight shaft	-	1
2.36	3001.000 239	cuscinetto/ball bearing	-	4
2.37	9730.336 239	vite/screw	-	4
2.38	=1050.955 239	ALBERO GOMITO/CRANKSHAFT (Pos. 2.27-2.28-2.38)		1
3.01	6975.330 240	puleggia dentata/belt pulley	1	1
3.02	7625.286 240	rondella/washer	1	1
3.03	7645.008 240	rondella/washer	1	1
3.04	1760.006 9	bullone/bolt	1	1
3.05	9730.012 9	vite/screw	4	4
3.06	2165.083 240	protezione cinghiette/belt guard	1	1
3.07	=1011.449 240	ALBERO CAMME COMPL./CAM SHAFT ASS.Y (Pos. 3.07-3.19-3.21)	1	1
3.08	1160.060 240	anello elast./lockwasher	2	2
3.09	7366.042 240	reticella/strainer	2	2
3.10	=2165.085 240	CARTER/COVER (Pos. 3.08-3.09-3.10)	1	1
3.11	1760.005 9	bullone/bolt	2	2
3.12	1770.014 9	bullone/bolt M 8 X 45	1	1
3.13	7645.006 240	rondella/washer	3	3
3.14	7645.006 9	rondella/washer	1	1
3.15	3203.050 9	dado/nut	1	1
3.16	7100.373 240	puleggia tendicinghia/jockey	1	1
3.17	2440.346 240	cinghia distr./timing belt	2	1
3.18	1301.334 240	anello elast./lockwasher	1	1
3.19	5801.568 240	molla decompress./spring	1	1
3.20	7770.175 240	rullo/roller d. 4 x 5	1	1
3.21	vedi/see Pos. 3.07	1	1
3.22	3001.069 9	cuscinetto/ball bearing	1	1
3.23	1241.055 240	anello seeger/snap ring 17X40X7	1	1
3.24	1213.356 240	anello tenuta/seal ring 17X40X7	1	1
3.25	6760.104 240	prigioniero/stud	1	1
3.26	3001.069 9	cuscinetto/ball bearing	1	1
3.27	6000.087 240	pastiglia/spacer 3,80	2	2
	6000.085 240	" " 3,90	2	2
	6000.091 240	" " 3,95	2	2
	6000.088 240	" " 4,00	2	2
	6000.092 240	" " 4,05	2	2
	6000.089 240	" " 4,10	2	2
	6000.093 240	" " 4,15	2	2
	6000.090 240	" " 4,20	2	2
	6000.094 240	" " 4,25	2	2
3.28	7215.114 240	punteria/rod	2	2
3.29	6400.083 240	piattello/cup	2	2
Motore/Engine	LGA 280	Versione/Version standard		
"	LGA 340	" " "		

 LGA 280 - LGA 340 vedi Tavola Ric./see Parts Table 1.5302.483				LGA 280	LGA 340
Pos.	Matricola/Part No.		Note/Remarks		
3.30	1213.357	240	anello paraolio/ring	2	2
3.31	3527.430	240	distanziale/spacer	1	1
3.32	7625.008	9	rondella/washer	1	1
3.33	1760.034	9	bullone/bolt	1	1
3.34	6975.329	240	puleggia conduttrice/drive pulley	1	1
3.35	5755.146	240	molla valvola/valve spring	2	2
3.36	6400.084	240	piattello con semiconi/retainer	2	2
3.37	1160.058	240	anello elast./lockwasher	1	1
3.38	1160.059	240	anello elast./lockwasher	1	1
3.39	=4845.244	240	GUIDA ASPIRAZ./INLET GUIDE (Pos. 3.38-3.39)	1	1
3.40	=4845.245	240	GUIDA SCARICO/EXHAUST GUIDE (Pos. 3.37-3.40)	1	1
3.41	8000.210	240	sede valv.scar./exh. valve seat	1	-
"	8000.215	239	sede valv.scar./exh. valve seat	-	1
3.42	9685.143	240	valvola scarico/exhaust valve	1	-
"	9685.147	239	valvola scarico/exhaust valve	-	1
3.43	9652.150	240	valvola aspiraz./inlet valve	1	-
"	9652.154	239	valvola aspiraz./inlet valve	-	1
3.44	8000.209	240	sede valv.asp./inlet valve seat	1	-
"	8000.214	239	sede valv.asp./inlet valve seat	-	1
4.01	9580.075	240	tubo sfiato/breather hose	1	1
4.02	3630.161	240	fascetta/clamp	2	2
4.03	6140.472	240	perno/pin	1	1
4.04	7520.012	240	rondella/washer	1	1
4.05	5200.956	240	leva comando/control lever	1	1
4.06	1760.132	240	vite/screw	2	2
4.07	7520.012	240	rondella/washer	1	1
4.08	5801.570	240	molla/spring	4	4
4.09	5801.567	240	distanziale/spacer	1	1
4.10	5200.943	240	leva/lever	1	1
4.11	1585.200	240	boccola/bushing	1	1
4.12	5670.019	240	molla/spring	1	1
4.13	1760.130	9	bullone/bolt	2	2
4.14	7520.017	9	rondella/washer	1	1
4.15	=2690.353	240	PIASTRA COM. A MANO/HAND CONTROL (Pos. 4.03-4.04-4.05-4.06-4.07- 4.08-4.09-4.15-4.16-4.18-4.19)	1	1
4.16	7625.008	9	rondella/washer	1	1
4.18	3240.008	9	dado/nut	1	1
4.19	3240.004	9	dado/nut	2	2
4.20	5830.168	240	passafilo/wire-sleeve	1	1
4.21	3695.083	240	filo comando/governor wire	1	1
4.22	3203.050	9	dado/nut	2	2
4.23	7701.190	240	rondella/washer	1	1
4.24	7520.013	240	rondella/washer	1	1
4.25	5725.047	240	molla/spring	1	1
4.26	7520.013	240	rondella/washer	1	1
4.27	3203.038	9	dado/nut	1	1
Motore/Engine	LGA 200		Versione/Version standard		
"	"	LGA 340	"	"	"

 LGA 280 - LGA 340 vedi Tavola Ric./see Parts Table 1.5302.483				LGA 280	LGA 340
Pos.	Matricola/Part No.		Note/Remarks		
4.28	7520.012	240	rondella/washer	2	2
4.29	1165.035	240	anello benzina/circlip d.7	2	2
4.30	5801.569	240	molla/spring	1	1
4.31	1415.047	240	asta regolat./governor rod	1	1
4.32	=8741.157	240	SUPPORTO FILTRO/AIR FILTER SUPPORT (Pos. 4.32-4.33)	1	1
4.33	6760.105	240	prigioniero/stud	1	1
4.34	ex 3585.050	- - - -	sostituito da/superseded by - - - - >		
	-> 5496.338	240	I massa filtrante/filtering element	1	1
4.35	ex 3585.048	- - - -	sostituito da/superseded by - - - - >		
	-> 2175.168	240	I CARTUCCIA COMPLETA/FILTERING ELEMENT (Pos. 4.35-1.34)	1	1
4.36	=2605.104	240	COPERCHIO FILTRO/AIR FILTER COVER (Pos. 4.23-4.24-4.25-4.26-4.37- 4.39-4.40)	1	1
4.37	6545.018	240	pomello/knob	1	1
4.38	7362.310	240	regolatore completo/speed control	1	1
4.39	7626.017	9	rondella/washer	4	4
4.40	9730.004	9	vite/screw	4	4
5.01	ex=8103.299	240	B -> da/from s.No. 7500673 -> CT 25001 ->	1	1
	-> 8103.301	239	A SERBATOIO COMPLETO/FUEL TANK ASS.Y (Pos. 5.01-5.02-5.03-5.12-5.18- 5.19-5.41)	1	1
5.02	9043.086	240	Cappo serbatoio/tank cap	1	1
5.03	4775.536	240	B -> fino/until No.7500672 -> CT 25001 ->	v	v
5.04	1760.130	9	bullone/bolt	4	4
5.05	6927.395	240	protezione/guard	1	1
5.06	9732.064	9	vite/screw	2	2
5.07	7645.006	9	rondella/washer	2	2
5.08	4501.122	240	guarnizione scarico/gasket	1	1
5.09	3240.164	9	dado/nut	2	2
5.10	2942.179	240	curva aspiraz./inlet elbow	1	1
5.11	9235.027	240	tirante/rod	1	1
5.12	3730.097	240	B -> fino/until No.7500672 -> CT 25001 ->	v	v
5.13	4420.073	240	guarnizione scarico/gasket	1	1
5.14	6760.106	240	prigioniero/stud	2	2
5.15	4470.019	240	guarnizione carbur./gasket	1	1
5.16	4775.533	240	guarnizione carbur./gasket	1	1
5.18	3630.163	240	B -> fino/until No.7500672 -> CT 25001 ->	v	v
5.19	7755.107	240	B -> fino/until No.7500672 -> CT 25001 ->	v	v
5.20	8865.184	240	staffa/brace	1	1
5.21	1760.130	9	bullone/bolt	1	1
5.22	8865.185	240	supporto/support	1	1
5.23	2151.266	240	carburatore/carburator FHBC 25/20	1	-
	2151.273	239	carburatore/carburator FHBC/.	-	1
5.24	7625.282	240	rondella/washer	2	2
5.25	1970.416	240	bussola/sleeve	2	2
Motore/Engine	LGA 280		Versione/Version standard		
"	LGA 340		"		

LOMBARDINI MOTORI F.I.M. S.p.a.

Edizione dell/Issue of 11.1997



vedi tavola Ric./see parts table 10000000

POS.	Matricola/Part No.	Note/Remarks	LGA	LGA
6.14		pulsante spurgo/drain push botton	1	1
6.15		vite/screw	1	1
6.16		asta farfalla/throttle rod	1	1
6.17		farfalla starter/choke plate	1	1
6.18		vite/screw	1	1
6.19	4126.084 240	getto min/idle jet	1	1
6.20	9850.127 240	valvola spillo/needle valve	1	1
6.21		perno galleggiante/float pin	1	1
6.23		vite/screw	1	1
6.24	=8180.198 240	SERIE GUARNIZIONI/GASKET SET	1	1
7.01	=1471.089 196	AVVIATORE COMPLETO/RECOIL ASS.Y	1	1
7.02	1760.130 9	bullone/bolt	4	4
7.04	vedi/see Pos. 7.01	1	1
7.06	7980.063 196	scodellino/cup	1	1
7.07	5590.026 196	molla/spring	1	1
7.08	5025.094 196	dente/tooth	1	1
7.09	7100.371 196	puleggia autoavv./recoil pulley	1	1
7.10	5801.539 196	molla autoavv./recoil spring	1	1
7.11	1165.006 9	anello benzina/circlip d.7	1	1
7.12	vedi/see Pos. 7.01	1	1
7.13	5660.066 196	molla/spring	1	1
7.15	5025.094 196	dente/tooth	1	1
7.16+	vedi/see Pos. 17	1	1
7.17	4904.039 196	IMPUGNATURA + fune/HANDLE with rope (Pos. 7.16 7.17)	1	1
7.18	3527.470 239	colonneta/hollowstud (avv.el./el.st)	4	4
7.19	3527.471 239	colonneta/hollowstud (autoavv/rewind)	4	4
7.19	4501.130 239	guarnizione/joint	1	1
7.20	1760.130 9	bullone/bolt	4	4
7.21	7951.193 239	scatola protez./guard (avv.el./el.st)	1	1
7.21	7951.194 239	scatola protez./guard (autoavv/rewind)	1	1
8.01	=9881.215 240	VOLANO COMPLETO/FLYWHEEL ASS.Y (Pos. 8.01-8.10)	1	1
8.02	9730.297 9	vite/screw	6	6
8.03	7645.008 240	rondella/washer	2	2
8.04	9732.018 9	vite/screw M 6 X 45	2	2
8.05	3617.203 240	fascetta/clamp d. 40 - 60	1	1
8.06	9732.079 9	vite/screw	2	2
8.07	7645.008 240	rondella/washer	2	2
8.08	5840.188 240	motorino avviam./starting motor	1	1
8.09	1157.296 240	alternatore/alternator 12 V 70 W	1	1
8.10	2816.106 240	corona avviam./crown gear	1	1
8.11	8430.107 240	spina/lockpin	1	1
Motore/Engine	LGA 280	Versione/Version standard		
"	LGA 340	" " "		

LOMBARDINI MOTORI F.I.M. S.p.a.

Edizione del/Issue of 11.1997

20/04 '00 13:55

TX/RX NO. 8568

P03

20/04 '00 12:57

☎ 32 2 478 32 42

BERNARD BEL LUX --- ST-HUBERT

☑ 004

pag. 9 / 10

**LGA 280 - LGA 340**
vedi Tavola Ric./see Parts Table 1.5302.483

Pos.	Matricola/Part No.	Note/Remarks	LGA 280	LGA 340
8.12	-1510.776 240 =1510.789 239	BASAMENTO avv.el./EL.START.CRANKCASE (Pos. 1.24-1.25-1.38-1.39-4.28-4.29-4.31-8.12)	1 -	- 1
8.13	8400.138 240	spina/lockpin	2	2
8.14	8430.107 240	spina/lockpin	2	2
8.15	6370.334 240	piastrina/safety plate	1	1
8.16	7830.015 240	ruttore/starter switch	1	1
8.17	6607.016 240	ponte raddrizz./rectifier bridge	1	1
9.01	2185.920 240	cavetto/wire	1	1
9.02	5041.257 239	interruttore/key switch	1	1
9.03	8345.057 239	spia centralina/warning device	1	1
9.04	3203.050 9	dado/nut	1	1
9.05	8865.185 240	supporto/support	1	1
9.06	3203.050 9	dado/nut	1	1
9.07	2185.935 239	cavetto/wire	1	1
9.08	6607.016 240	ponte raddrizz./rectifier bridge	1	1
9.09	5840.188 240	motorino avviam./starting motor	1	1
9.10	1760.005 9	bullone/bolt	2	2
9.11	7830.015 240	ruttore/starter switch	1	1
9.12	6330.090 239	piastrina/plate	1	1
9.13	1760.134 239	bullone/bolt	1	1
9.14	2185.932 239	cavo elettrico/electrical wire	1	1
9.15	2185.931 239	cavo elettrico/electrical wire	1	1
10.01	4906.049 239	indicatore elettrico/elect.gauge	1	1
10.02	2185.920 240	cavetto/wire	1	1
10.03	2185.934 239	cavetto/wire	1	1
10.04	5041.258 239	interruttore/switch	1	1
10.05	3527.432 240	colonna/hollowstud	1	1
10.06	1760.130 9	bullone/bolt	1	1
10.07	1200.293 240	anello tenuta/seal joint	1	1
10.08	2185.935 239	cavetto/wire	1	1
10.09	3203.038 9	dado/nut	1	1
10.10	5981.085 239	lamiera/panel	1	1
10.11	1760.132 240	vite/screw	1	1
10.12	8903.101 239	supporto spia/warning light support	1	1
10.13	8345.057 239	spia centralina/warning device	1	1
10.14	8903.101 239	supporto spia/warning light support	1	1
10.15	7626.017 9	rondella/washer	1	1
10.16	3260.130 239	dado/nut	1	1
10.17	8345.057 239	spia centralina/warning device	1	1
10.18	5041.257 239	interruttore/key switch	1	1
10.19	6607.016 240	ponte raddrizz./rectifier bridge	1	1
10.20	3260.130 239	dado/nut	1	1
10.21	3527.432 240	colonna/hollowstud	1	1
10.22	2185.920 240	cavetto/wire	1	1
10.23	2185.934 239	cavetto/wire	1	1
10.24	1760.130 9	bullone/bolt	1	1
Motore/Engine	LGA 280	Versione/Version standard		
" "	LGA 340	" "		

Cour goldoni special Disc 128	
moten LGA 340	- 2.000
rodelment support	6200007
rodant endroage	2057068
* -dode -cote moten	2037079
gouffois	6780005
rondelles	7555074
cirous	324029

