

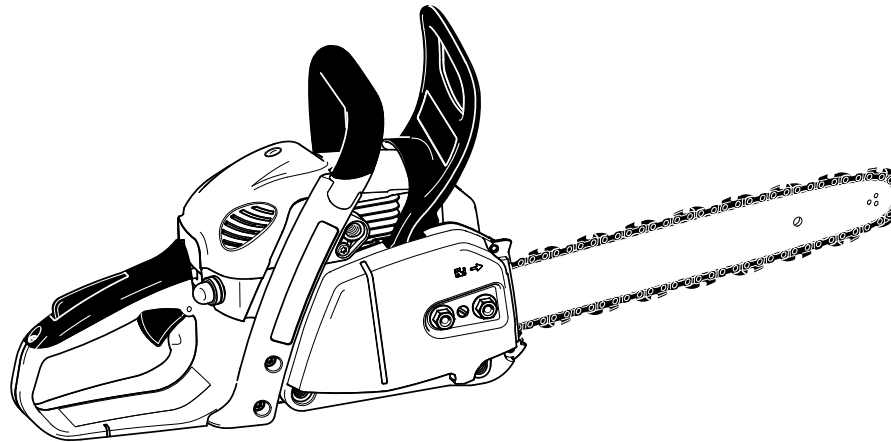

Spare Parts List
Ersatzteilliste
Liste de pièces détachées
Lista de piezas de repuesto

2012-09



EA3500S
EA3501S
EA3502S
EA3503S
MEA3502L

995700589 (D, GB, F, E)

EA3500S, EA3501S,
EA3502S, EA3503S,
MEA3502L

1

Kraftstofftank, Bügelgriff
Fuel tank, tubular grip
Réserv. carburant, poignée tubulaire
Depósito de combustible, mango tubular

Makita[®]

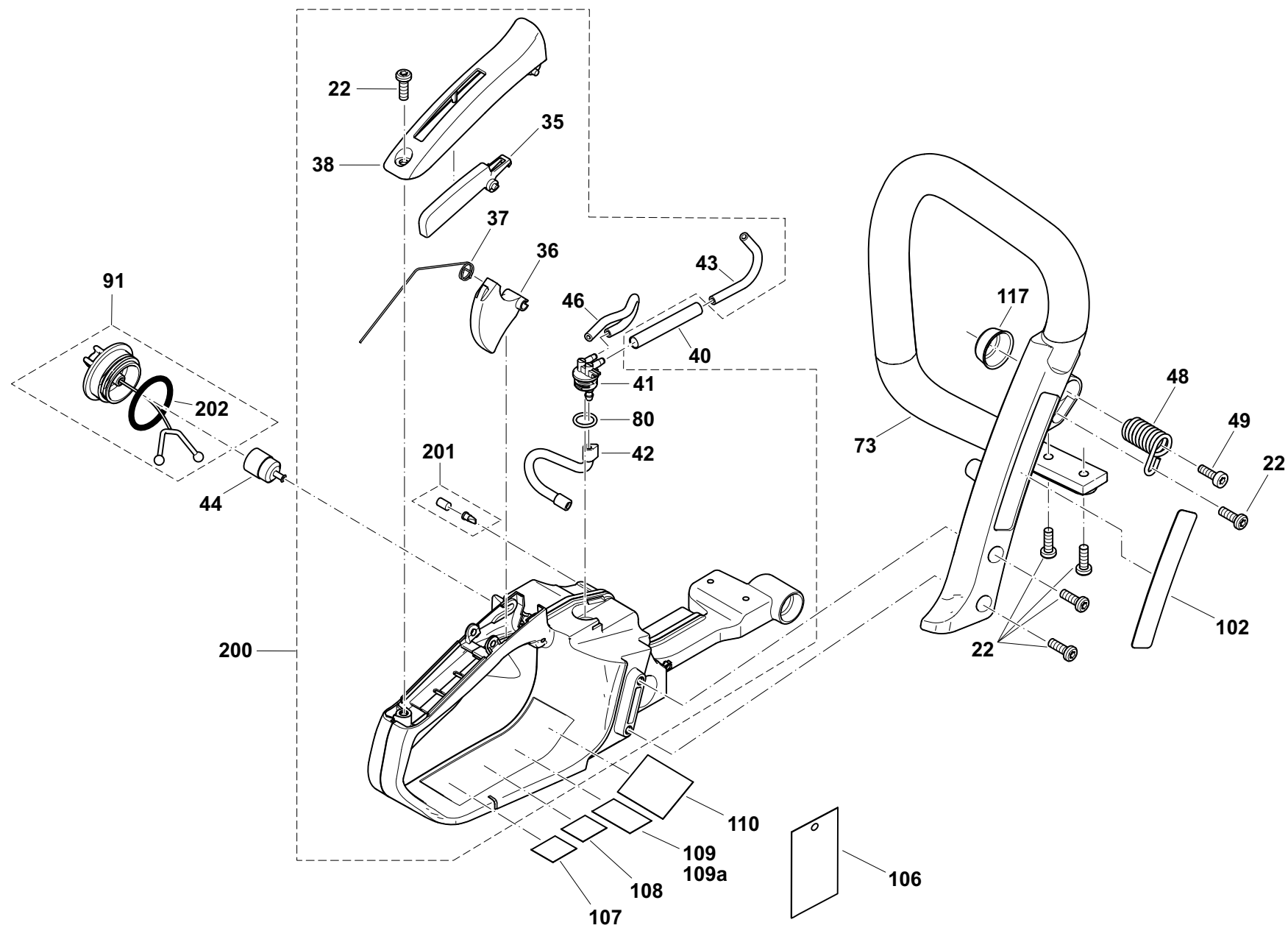

EA3500S, EA3501S,
EA3502S, EA3503S,
MEA3502L

1

Kraftstofftank, Bügelgriff
Fuel tank, tubular grip
Réserv. carburant, poignée tubulaire
Depósito de combustible, mango tubular



Seite / Page	Pos.	EA3500S	EA3501S	EA3502S	EA3503S	MEA3502L	Teil-Nr. Part No. No. de pièce No. de pieza	Hinweise Notes Renseign. Nota	Bezeichnung	Spezifikation Specification	Description	Désignation	Denominación
1	22	19	19	19	19	19	913 455 164		INNENSTERN SCHRAUBE	5,5X16	SCREW	VIS	TORNILLO
1	35	1	1	1	1	1	165 117 030		GASHEBELSPERRE		CATCH LEVER	LEVIER DE VERROUILLAGE	PALANCA TRINCADA
1	36	1	1	1	1	1	165 117 020		GASHEBEL		THROTTLE LEVER	ACCÉLÉRATEUR	PALANCA DEL ACELERADOR
1	37	1	1	1	1	1	165 117 010		GASHEBELFEDER		TORSION SPRING	RESSORT	MUELLE
1	38	1	1	1	1	1	165 117 050		GRIFFOBERSCHALE		GRIP SHELL	COQUILLE DE POIGNÉE SUPÉR.	CUBIERTA SUPER. EMPUÑADURA
1	40	m	m	m	m	m	970 502 110		ISOLIERSCHLAUCH	A6X0,5 L=50 mm	ISOLATING HOSE	TUYAU ISOLANT	MANGO AISLANTE
1	41	1	1	1	1	1	195 114 060		KRAFTSTOFFNIPPEL		FUEL NIPPLE	RACCORD FILETÉ	RACOR
1	42	1	1	1	1	1	195 114 050		KRAFTSTOFFLEITUNG		FUEL LINE	CONDUITE CARB.	TUBO COMB.
1	43	1	1	1	1	1	965 452 660		VITONSCHLAUCH	5,6/3mmx1m EPA code, redL=75 mm	TUBE	GAINE	TUBO
1	44	1	1	1	1	1	320 163 447		BENZINFILTER		FUEL FILTER	FILTRE D'ESSENCE	FILTRO DE GASOLINA
1	46	1	1	1	1	1	965 452 090		VITONSCHLAUCH	2,5/5,5mm x1m L=112 mm	TUBE	GAINE	TUBO
1	48	4	4	4	4	4	165 114 150		DÄMPFUNGSFEDER	12	COMPRESSION SPRING	RESSORT	RESORTE
1	49	6	6	6	6	6	908 005 165		SCHRAUBE INNEN6RD ZK	M5x16	H.L. SOCKET HEAD BOLT	VIS	TORNILLO
1	73	1	1	1	1	1	165 310 010		BÜGELGRIFF		TUBULAR HANDLE	POIGNEE TUBULAIRE	MANGO TUBULAR
1	80	1	1	1	1	1	963 211 020		O-RING	11,5x2	O RING	ANNEAU TORIQUE	ANILLO OBTURADOR
1	91	2	2	2	2	2	181 114 202		TANKDECKEL KPL.		TANK CAP CPL.	BOUCHON RESERVOIR CPL.	TORNILLO DE CIERRE CPL.
1	102	1	1	1	1	1	165 115 690		SCHILD BÜGELGRIFF	MAKITA LOGO	LABEL	PLAQUE	CALCOMANIA
1	106	1	1	1	1	1			ANHÄNGESCHILD	AIR INDEX, USA	TAG	PLAQUE	PLACA
1	107	1	1	1	1		125 115 060		SICHERHEITSAUFKLEBER	USA	CAUTION LABEL	PLAQUE	CALCOMANIA
1	107	1	1	1	1				AUFKLEBER	BR	LABEL	PLAQUE	CALCOMANIA
1	107					1	125 115 140		SICHERHEITSAUFKLEBER	J	CAUTION LABEL	PLAQUE	CALCOMANIA
1	108	1	1	1	1				SCHALLPEGELAUFKLEBER	EU, USA	LABEL, SOUND LEVEL	PLAQUE, SONORE	CALCOMANIA, NIVEL DE SONORA
1	108	1	1	1	1				SCHALLPEGELAUFKLEBER	AUS, NZ	LABEL, SOUND LEVEL	PLAQUE, SONORE	CALCOMANIA, NIVEL DE SONORA
1	109	1	1	1	1				ABGASAUFKLEBER	EU	LABEL, EXHAUST EMISSION	PLAQUE, GAZ D'ÉCHAPPEMENT	CALCOMANIA, GAS DE ESCAPE
1	109	1	1	1	1				ABGASAUFKLEBER	USA	LABEL, EXHAUST EMISSION	PLAQUE, GAZ D'ÉCHAPPEMENT	CALCOMANIA, GAS DE ESCAPE
1	109a	1	1	1	1	1			AUFKLEBER TANK	USA - EVAPORATION MAKITA	LABEL, TANK	PLAQUE, RÉSERVOIR	CALCOMANIA, DEPÓSITO
1	110	1	1	1	1	1			TYPENSCHILD		NAME PLATE	PLAQUE SIGNATIQUE	PLACA DE CARACTERÍSTICAS
1	117	1	1	1	1	1	195 114 160		FEDERTOPF		SPRING GUIDING HEAD	TÊTE DE GUIDE DE RESSORT	COPA DE GUÍA DEL MUELLE
1	200	1	1	1	1	1	125 114 640		KRAFTSTOFFTANK KPL. BLAU	BLUE	TANK COMPLETE	RÉSERVOIR COMPLET	DEPÓSITO CPL.
1	200	1	1	1	1	1	125 114 650		KRAFTSTOFFTANK KPL. BLAU	BLUE, USA (EPA), INCL.109a	TANK COMPLETE	RÉSERVOIR COMPLET	DEPÓSITO CPL.
1	201	1	1	1	1	1	170 175 010		SATZ BELÜFTUNGSVENTIL		AIR VALVE CPL.	SOUPAPE D'AERATION CPL.	VÁLVULA VENTILACION CPL.
1	202	2	2	2	2	2	963 229 036		O-RING	29,3X3,6	PACKING RING	BAGUE-JOINT	ANILLO DE GUARNICION

EA3500S, EA3501S,
EA3502S, EA3503S,
MEA3502L

2

Abdeckhaube, Luftfilter, Schalldämpfer
Hood, air filter, muffler
Capot protecteur, filtre à air, pot d'échappement
Cubierta protectora, filtro de aire, silencioso

Makita[®]

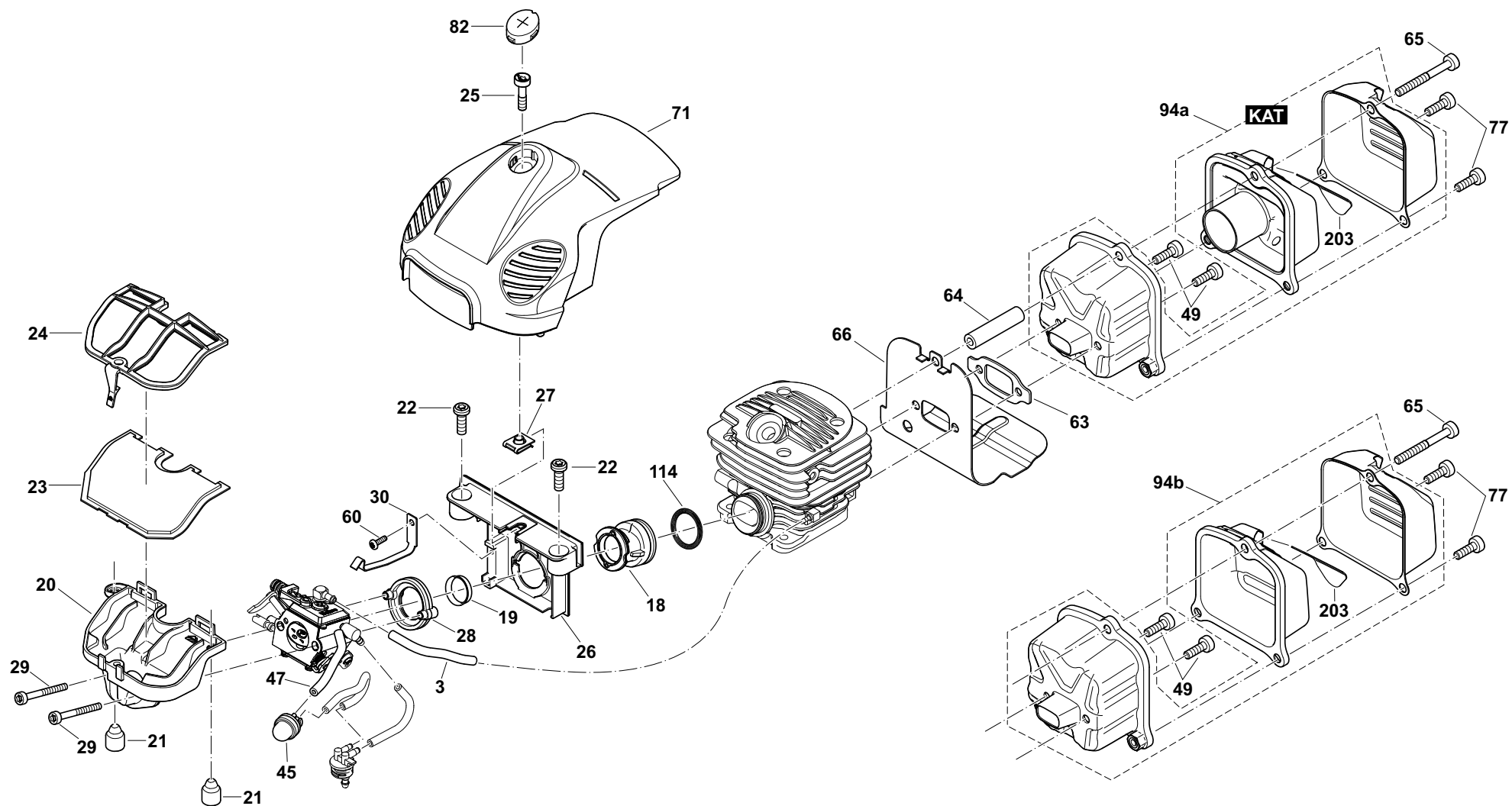

EA3500S, EA3501S,
EA3502S, EA3503S,
MEA3502L

2

Abdeckhaube, Luftfilter, Schalldämpfer
Hood, air filter, muffler
Capot protecteur, filtre à air, pot d'échappement
Cubierta protectora, filtro de aire, silencioso



Seite / Page	Pos.	EA3500S	EA3501S	EA3502S	EA3503S	MEA3502L	Teil-Nr. Part No. No. de pièce No. de pieza	Hinweise Notes Renseign. Nota	Bezeichnung	Spezifikation Specification	Description	Désignation	Denominación
2	3	1	1	1	1	1	965 452 090		VITONSCHLAUCH	2,5/5,5mm x1m L=72 mm	TUBE	GAINÉ	TUBO
2	18	1	1	1	1	1	125 131 040		ANSAUGSCHLAUCH		INTAKE HOSE	TUYAU D'ASPIRATION	TUBO DE ASPIRACIÓN
2	19	1	1	1	1	1	185 131 020		EINSATZ FÜR ANSAUGSCHLAUCH	17	BUSH	DOUILLE	CASQUILLO
2	20	1	1	1	1	1	165 171 010		ANSAUGKRÜMMER		INTAKE MANIFOLD	MANCHON DE JONCTION	MANGUITO DE CON.
2	21	2	2	2	2	2	181 118 070		DÄMPFUNGSSTOPFEN		DAMPING PLUG	TAMPON	TAPÓN DE AMORTIGUACIÓN
2	22	17	17	17	17	17	913 455 164		INNENSTERN SCHRAUBE	5,5X16	SCREW	VIS	TORNILLO
2	23	1	1	1	1	1	125 173 010		LUFTFILTER		AIR FILTER	FILTRE A AIR	FILTRE A AIR
2	24	1	1	1	1	1	165 173 020		LUFTFILTERDECKEL		AIR FILTER COVER	COUVERCLE DE FILTRE	TAPE DE FILTRO
2	25	1	1	1	1	1	908 605 205		SCHRAUBE INNEN6RD	M5x20	SCREW	VIS	TORNILLO
2	26	1	1	1	1	1	125 131 050		ZWISCHENFLANSCH		INTERMEDIATE FLANGE	BRIDE INTERMEDIAIRE	BRIDA INTERMEDIA
2	27	1	1	1	1	1	165 171 020		SCHNAPPMUTTER	M5	SNAP NUT	ECROU	TUERCA
2	28	1	1	1	1	1	165 131 060		FLANSCHRING		FLANGE RING	BRIDE DE ANNEAU	BRIDA DE COLLAR
2	29	2	2	2	2	2	908 004 406		SCHRAUBE INNEN6RD ZK	M4X40, 10.9	H.L. SOCKET HEAD BOLT	VIS	TORNILLO
2	30	1	1	1	1	1	165 155 010		KONTAKTFEDER		CONTACT SPRING	RESSORT DE CONTACT	MUELLE DE CONTACTO
2	45	1	1	1	1	1	010 155 010		KRAFTSTOFFPUMPE	PRIMER	PRIMER	POMPE À CARBURANT	BOMBA DE COMBUSTIBLE
2	47	1	1	1	1	1	965 452 090		VITONSCHLAUCH	2,5/5,5mm x1m L=55 mm	TUBE	GAINÉ	TUBO
2	49	4	4	4	4	4	908 005 165		SCHRAUBE INNEN6RD ZK	M5x16	H.L. SOCKET HEAD BOLT	VIS	TORNILLO
2	60	4	4	4	4	4	165 888 120		SCHRAUBE	3X10 KS K	TAPPING SCREW	VIS	TORNILLO
2	63	1	1	1	1	1	165 174 060		DICHTUNG		GASKET	JOINT	JUNTA
2	64	1	1	1	1	1	038 174 410		ZWISCHENSTÜCK		CONNECTING LINK	INTERMEDIAIRE	PIEZA INTERMEDIARIA
2	65	1	1	1	1	1	908 505 555		SCHRAUBE INNEN6RD ZK	M5x55	H.L. SOCKET HEAD BOLT	VIS	TORNILLO
2	66	1	1	1	1	1	125 174 180		KÜHLBLECH		COOLING PLATE	TÔLE DE REFROIDISSEMENT	CHAPA DE REFRIGERACION
2	71	1	1	1	1	1	125 118 010		ABDECKHAUBE		HOOD	CAPOT PROTECTEUR	TAPA PROTECTORA
2	77	2	2	2	2	2	909 005 105		SCHRAUBE	M5x10	SCREW	VIS	TORNILLO
2	82	1	1	1	1	1	125 118 020		STOPFEN		PLUG	BOUCHON	TAPÓN
2	94a	1	1			1	125 174 100		SCHALLDÄMPFER KPL.	KAT	MUFFLER CPL.	POT D'ECHAPPEMENT CPL.	SILENCIADOR CPL.
2	94a	1	1				125 174 101		SCHALLDÄMPFER KPL.	KAT (USA/CDN)	MUFFLER CPL.	POT D'ECHAPPEMENT CPL.	SILENCIADOR CPL.
2	94b			1	1		125 174 200		SCHALLDÄMPFER KPL.		MUFFLER CPL.	POT D'ECHAPPEMENT CPL.	SILENCIADOR CPL.
2	114	1	1	1	1	1	181 131 070		RINGFEDER		ANNULAR SPRING	RESSORT ANNULAIRE	MUELLE DE ANILLO
2	203	1	1	1	1	1	125 174 170		FUNKENSCHUTZSIEB		SPARK ARRESTER SCREEN	TAMIS	TAMIZ

EA3500S, EA3501S,
EA3502S, EA3503S,
MEA3502L

3

Zylinder, Kurbelwelle
Cylinder, crankshaft
Cylindre, vilebrequin
Cilindro, cigüeñal

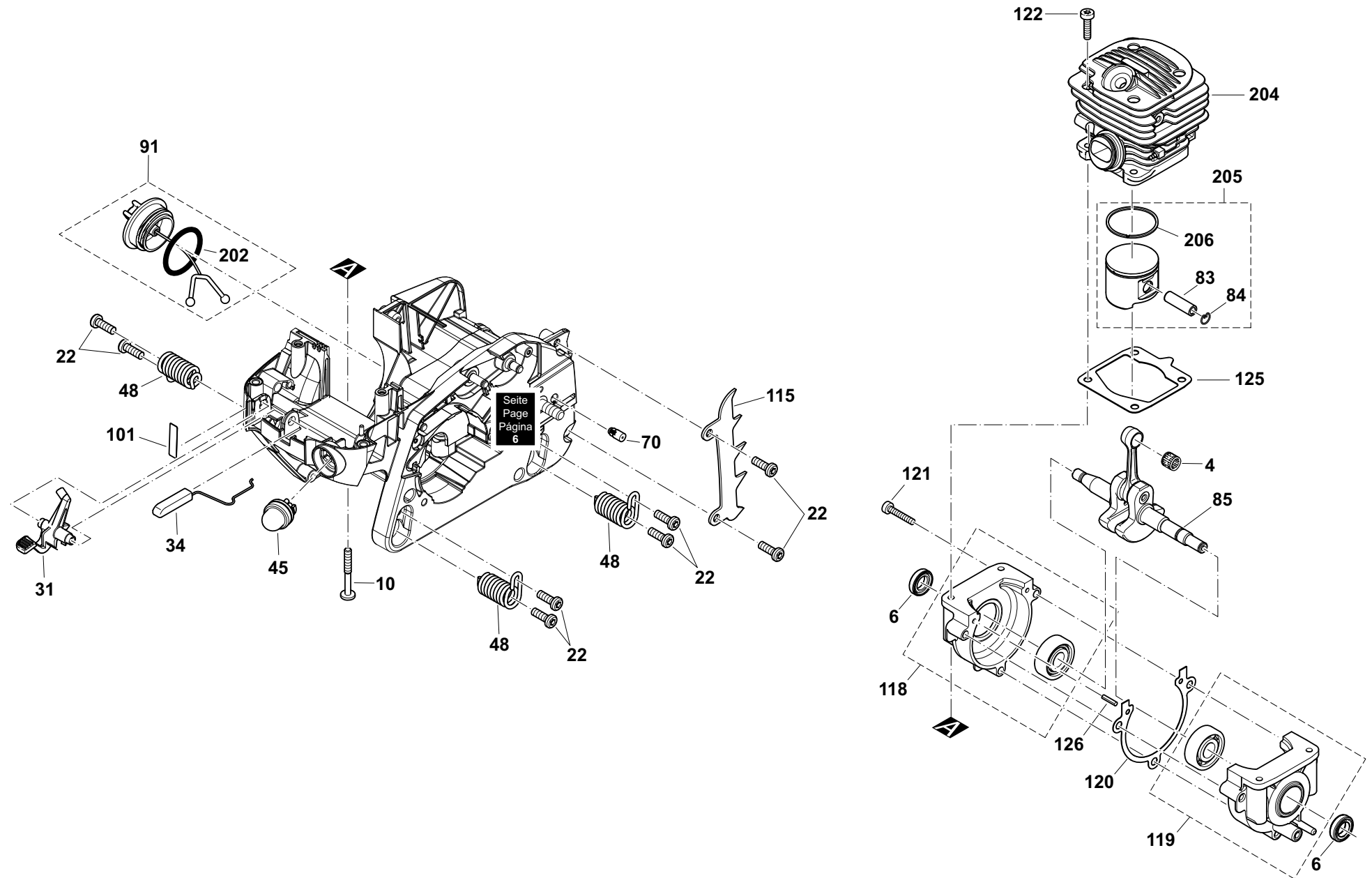

EA3500S, EA3501S,
EA3502S, EA3503S,
MEA3502L

3

Zylinder, Kurbelwelle
Cylinder, crankshaft
Cylindre, vilebrequin
Cilindro, cigüeñal



Seite / Page	Pos.	EA3500S	EA3501S	EA3502S	EA3503S	MEA3502L	Teil-Nr. Part No. No. de pièce No. de pieza	Hinweise Notes Renseign. Nota	Bezeichnung	Spezifikation Specification	Description	Désignation	Denominación
3	4	1	1	1	1	1	962 210 092		NADELKRANZ	KV9x12x11,5S	NEEDLE CAGE	CARTER-COTE	CARTER CIGUENAL
3	6	2	2	2	2	2	962 900 156		RADIALDICHTRING	Ø 12/20x4,5	RADIAL RING	JOINT RADIAL	ANILLO RADIAL
3	10	4	4	4	4	4	913 350 404		SCHRAUBE	5x40 E-JOT	SCREW	VIS	TORNILLO
3	22	17	17	17	17	17	913 455 164		INNENSTERN SCHRAUBE	5,5X16	SCREW	VIS	TORNILLO
3	31	1	1	1	1	1	165 155 020		CHOKEHEBEL		CHOKE LEVER	LEVIER DE STARTER	PALANCA ESTRANGUL.AIRE
3	34	1	1	1	1	1	125 117 110		GASGESTÄNGE KPL.		THROTTLE LINKAGE CPL.	TRINGLE D'ACCELERATION CPL.	VARILLA ACELERADOR CPL.
3	45	1	1	1	1	1	010 155 010		KRAFTSTOFFPUMPE	PRIMER	PRIMER	POMPE À CARBURANT	BOMBA DE COMBUSTIBLE
3	48	4	4	4	4	4	165 114 150		DÄMPFUNGSFEDER	12	COMPRESSION SPRING	RESSORT	RESORTE
3	70	1	1	1	1	1	010 245 030		BELÜFTUNGSVENTIL		VENT VALVE	SOUPAPE D AERATION	VALVULA VENTILACION
3	83	1	1	1	1	1	125 132 030		KOLBENBOLZEN	8	PISTON PIN	AXE DE PISTON	PERNO DE PISTON
3	84	1	1	1	1	1	108 132 050		SPRENGRING		SPRING RING	ANNEAU RESSORT	ANILO ELASTICO
3	85	1	1	1	1	1	125 120 100		KURBELWELLE KPL.		CRANKSHAFT CPL.	VILBREQUIN CPL.	CIGÜEÑAL CPL
3	91	2	2	2	2	2	181 114 202		TANKDECKEL KPL.		TANK CAP CPL.	BOUCHON RESERVOIR CPL.	TORNILLO DE CIERRE CPL.
3	101	1	1	1	1	1	185 114 928		SCHILD CHOKE-EIN-AUS	CHOKE-ON-OFF	LABEL	PLAQUE	CALCOMANIA
3	115	1	1	1	1	1	165 250 010		ZACKENLEISTE		SPIKE BAR	BARRE DENTÉE	BARRA DENTADA
3	118	1	1	1	1	1	125 111 070		KURBELGEHÄUSE KPL.	MS	CRANKCASE CPL.	CARTER-VILEBREQUIN CPL.	CÁRTER CIGÜEÑAL CPL.
3	119	1	1	1	1	1	125 111 080		KURBELGEHÄUSE KPL.	KS	CRANKCASE CPL.	CARTER-VILEBREQUIN CPL.	CÁRTER CIGÜEÑAL CPL.
3	120	1	1	1	1	1	125 111 090		KURBELGEHÄUSEDICHTUNG		CRANK CASE GASKET	JOINT	JUNTA
3	121	3	3	3	3	3	908 405 255		INNENSTERN-SCHRAUBE	M5x25	SCREW	VIS	TORNILLO
3	122	4	4	4	4	4	908 405 205		SCHRAUBE INNEN6RD ZK	M5x20	H.L. SOCKET HEAD BOLT	VIS	TORNILLO
3	125	1	1	1	1	1	125 131 010		ZYLINDERFUßDICHTUNG		GASKET	JOINT	JUNTA
3	126	2	2	2	2	2	936 430 160		SPIRALSPANNSTIFT	3X16	CLAMPING PIN	GOUPILLE	PASADOR
3	202	2	2	2	2	2	963 229 036		O-RING	29,3X3,6	PACKING RING	BAGUE-JOINT	ANILLO DE GUARNICION
3	204	1	1	1	1	1	125 131 200		ZYLINDER KPL.	D38MM	CYLINDER CPL.	CYLINDRE CPL.	CILINDRO CPL.
3	205	1	1	1	1	1	125 132 100		KOLBEN KPL.	D38MM	PISTON CPL.	PISTON CPL.	PISTÓN CPL.
3	206	1	1	1	1	1	125 132 020		KOLBENRING	Ø 38	PISTON RING	SEGMENT DE PISTON	SEGMENTO DE PISTÓN

EA3500S, EA3501S,
EA3502S, EA3503S,
MEA3502L

4

Zündelektronik, Anwerfvorrichtung
Ignition electronics, starter
Allumage électronique, dispositif de démarrage
Bobina encendido, dispositivo de arranque

Makita[®]

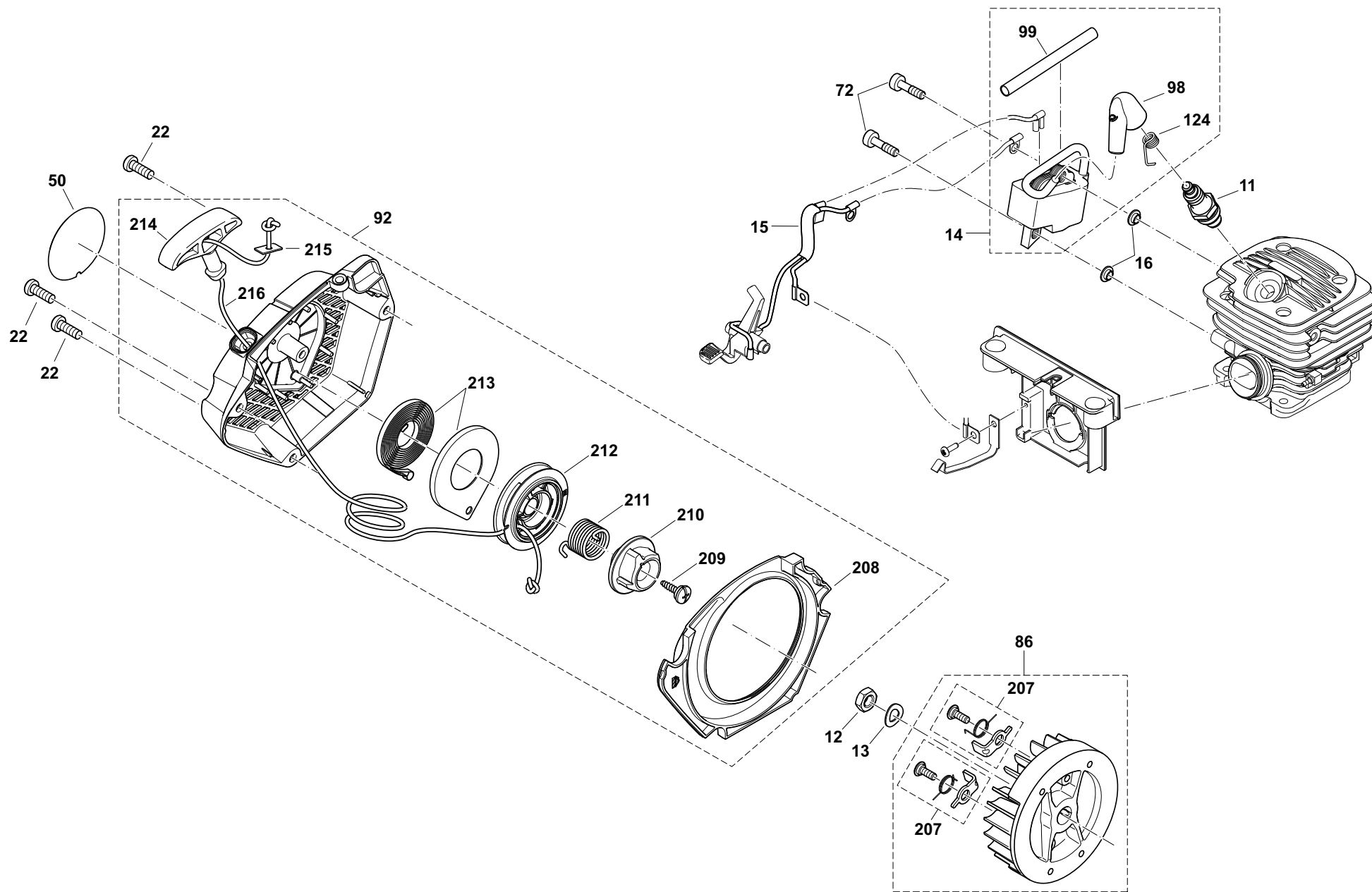

EA3500S, EA3501S,
EA3502S, EA3503S,
MEA3502L

4

Zündelektronik, Anwerfvorrichtung
Ignition electronics, starter
Allumage électronique, dispositif de démarrage
Bobina encendido, dispositivo de arranque



Seite / Page	Pos.	EA3500S	EA3501S	EA3502S	EA3503S	MEA3502L	Teil-Nr. Part No. No. de pièce No. de pieza	Hinweise Notes Renseign. Nota	Bezeichnung	Spezifikation Specification	Description	Désignation	Denominación
4	11	1	1	1	1	1	965 603 030		ZÜNDKERZE	NGK CMR6A	SPARK PLUG	BOUGIE	BUJÍA
4	12	1	1	1	1	1	920 308 024		6KT-MUTTER	M8x1	HEXAGONAL NUT	ECROU HEXAGONAL	TUERCA HEXAGONAL
4	13	1	1	1	1	1	926 208 001		FEDERSCHEIBE	B8	SPRING WASHER	RONDELLE ÉLASTIQUE	DISCO AMORTIGUADOR
4	14	1	1	1	1	1	125 143 100		ZÜNDSPULE		IGNITION COIL	BOBINE D' ALLUMAGE	BOBINA DE ENCENDIDO
4	15	1	1	1	1	1	165 147 020		KABELBAUM		CABLE HARNESS	FAISCEAU DE CABLES	MAZO DE CABLES
4	16	2	2	2	2	2	185 143 030		ISOLIERSCHEIBE		ISOLATING WASHER	RONDELLE	ARANDELA
4	22	17	17	17	17	17	913 455 164		INNENSTERN SCHRAUBE	5,5X16	SCREW	VIS	TORNILLO
4	50	1					125 115 110		SCHILD	EA3500S	MODEL LABEL	PLAQUE	CALCOMANIA
4	50		1				125 115 120		SCHILD	EA3501S	MODEL LABEL	PLAQUE	CALCOMANIA
4	50			1			125 115 115		SCHILD	EA3502S	MODEL LABEL	PLAQUE	CALCOMANIA
4	50				1		125 115 125		SCHILD	EA3503S	MODEL LABEL	PLAQUE	CALCOMANIA
4	50					1	125 115 100		SCHILD	MEA3502	MODEL LABEL	PLAQUE	CALCOMANIA
4	72	2	2	2	2	2	908 805 205		ZYLINDERSCHRAUBE MIT SPANNSCHEIBE	M5X20	SCREW	VIS	TORNILLO
4	86	1	1	1	1	1	165 141 100		POLRAD KPL.		FLYWHEEL COMPLETE	ROUE POLAIRE CPL.	VOLANTE ENCENDIDO CPL.
4	92	1	1	1	1	1	165 160 601		STARTER KPL. BLAU		STARTER ASSY., BLUE	DISPOS. DE DÉMARRAGE CPL. BLEU	DISPOS. DE ARRANQUE CPL. AZUL
4	98	1	1	1	1	1	125 143 010		ZÜNDKERZENSTECKER		SPARK PLUG CAP	FICHE DE BOUGIE	TAPA DE BUJÍA
4	99	m	m	m	m	m	125 143 040		ISOLIERSCHLAUCH	L=80 mm	ISOLATING HOSE	TUYAU ISOLANT	MANGO AISLANTE
4	124	1	1	1	1	1	125 143 020		FEDER		SPRING	RESSORT	RESORTE
4	207	1	1	1	1	1	165 166 100		ANWERFKLINKE KPL.		STARTER RATCHET CPL.	CLIQUET CPL.	TRINQUETE ARRANQUE CPL.
4	208	1	1	1	1	1	165 160 021		LUFTFÜHRUNG		AIR GUIDE PLATE	GUIDE D' AIR	CONDUCTO DE AIRE
4	209	1	1	1	1	1	195 160 010		SCHRAUBE		SCREW	VIS	TORNILLO
4	210	1	1	1	1	1	170 160 780		MITNEHMER	EASY START	STARTER WHEEL	ROUE DÉCLENCEUR	RUEDA DE ARRANQUE
4	211	1	1	1	1	1	195 160 030		FEDER		SPRING	RESSORT	MUELLE
4	212	1	1	1	1	1	195 160 040		SEILTROMMEL		CABLE DRUM CPL.	TAMBOUR DE CÂBLE CPL.	TAMBOUR PARA CORDÓN CPL.
4	213	1	1	1	1	1	195 160 110		STARTERFEDER		REWIND SPRING	RESSORT DE RAPPEL	RESORTE RETENCIÓN
4	214	1	1	1	1	1	195 160 070		ANWERFGRIF		STARTER GRIP	POIGNÉE DE LANCEMENT	TIRADOR DE ARRANQUE
4	215	1	1	1	1	1	195 160 080		SCHEIBE		WASHER	RONDELLE	ARANDELA
4	216	m	m	m	m	m	985 000 150		ANWERFSEIL	ø 3 x 100 m	STARTER ROPE	CÂBLE	CORDÓN DE ARRANQUE
4	216	1	1	1	1	1	021 164 010		ANWERFSEIL	ø 3 x 900 mm	STARTER ROPE	CÂBLE	CORDÓN DE ARRANQUE

EA3500S, EA3501S,
EA3502S, EA3503S,
MEA3502L

5

Ölpumpe, Kupplung, Kettenbremse
Oil pump, clutch, chain brake
Pompe à huile, embrayage, frein de chaîne
Bomba de aceite, engrague, freno de cadena

Makita[®]

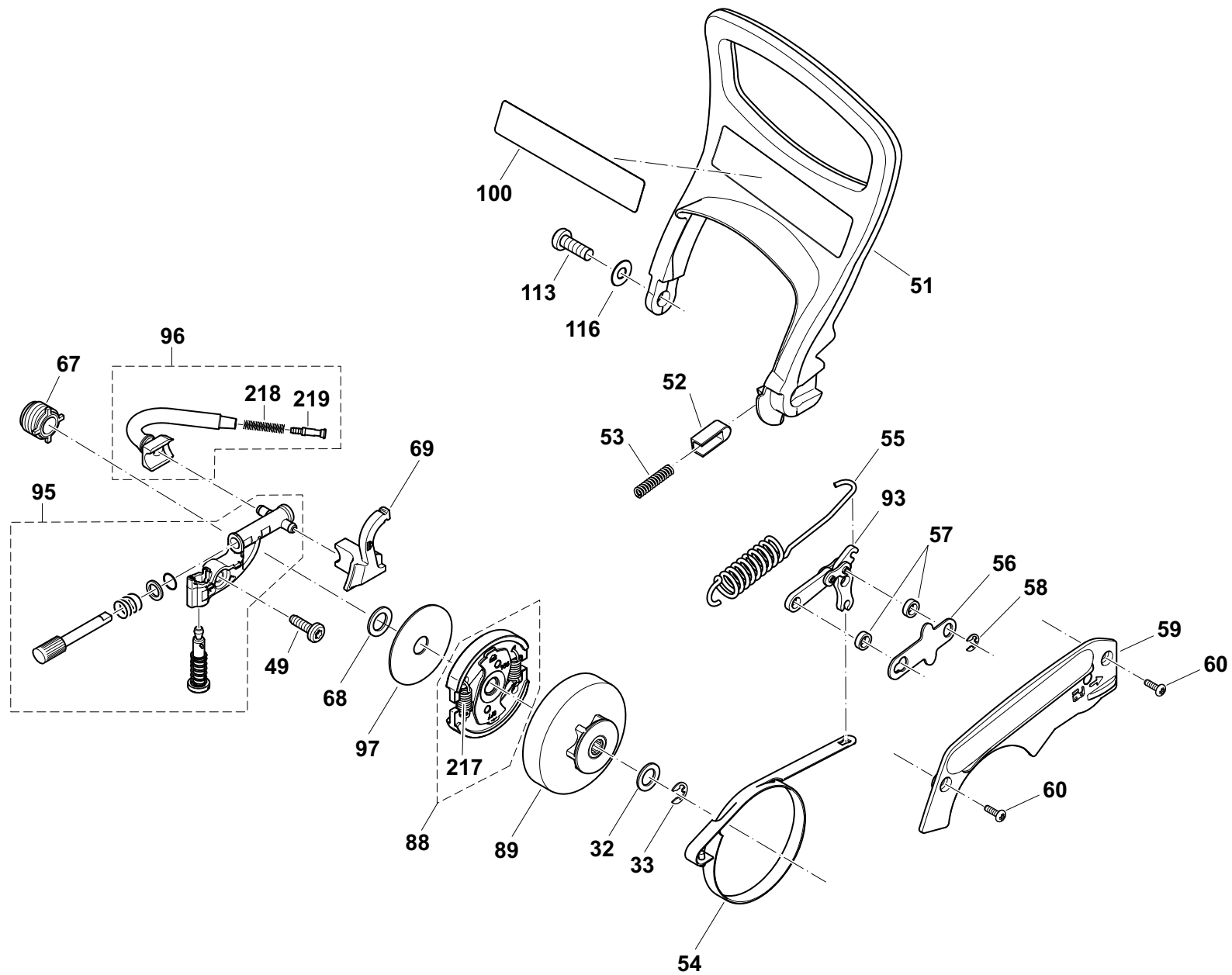

EA3500S, EA3501S,
EA3502S, EA3503S,
MEA3502L

5

Ölpumpe, Kupplung, Kettenbremse
Oil pump, clutch, chain brake
Pompe à huile, embrayage, frein de chaîne
Bomba de aceite, engrague, freno de cadena



Seite / Page	Pos.	EA3500S	EA3501S	EA3502S	EA3503S	MEA3502L	Teil-Nr. Part No. No. de pièce No. de pieza	Hinweise Notes Renseign. Nota	Bezeichnung	Spezifikation Specification	Description	Désignation	Denominación
5	32	1	1	1	1	1	900 006 065		PASSSCHEIBE	ø8/14x1	WASHER	RONDELLE	ARANDELA
5	33	1	1	1	1	1	927 306 000		SICHERUNGSSCHEIBE		SAFETY WASHER	RONDELLE SÉCURITÉ	ARANDELA SEGURIDAD
5	49	6	6	6	6	6	908 005 165		SCHRAUBE INNEN6RD ZK	M5x16	H.L. SOCKET HEAD BOLT	VIS	TORNILLO
5	51	1	1	1	1	1	165 213 051		HANDSCHUTZ		HAND GUARD	PROTÈGE-MAIN	PROTECTOR DE MANO
5	52	1	1	1	1	1	185 213 070		KULISSE FÜR HANDSCHUTZ		HAND GUARD GUIDE	COULISSE P. PROTÈGE-MAINS	CULISA P. PROTECCIÓN DE MANOS
5	53	1	1	1	1	1	185 213 060		DRUCKFEDER		COMPRESSION SPRING	RESSORT DE PRESSION	RESORTE DE PRESIÓN
5	54	1	1	1	1	1	165 213 010		BREMSBAND		BRAKE BAND	RESSORT DE FREIN	CINTA DE FRENO
5	55	1	1	1	1	1	165 213 120		ZUGFEDER		TENSION SPRING	RESSORT	MUELLE
5	56	1	1	1	1	1	165 213 130		ABSTANDSBLECH		SPACER SHEET METAL	TÔLE DE DISTANCE	CHAPA DE SEPARADOR
5	57	2	2	2	2	2	165 213 140		BUCHSE		BUSH	DOUILLE	CASQUILLO
5	58	1	1	1	1	1	927 304 000		SICHERUNGSSCHEIBE		SAFETY WASHER	RONDELLE SÉCURITÉ	ARANDELA SEGURIDAD
5	59	1	1	1	1	1	165 213 190		ABDECKUNG KETTENBREMSE		CHAIN BRAKE COVER	COUVERCLE	CUBIERTA
5	60	4	4	4	4	4	165 888 120		SCHRAUBE	3X10 KS K	TAPPING SCREW	VIS	TORNILLO
5	67	1	1	1	1	1	165 245 130		SCHNECKE		PUMP DRIVE	LE COMMANDE DE POMPE	PROPULSOR DE LA BOMBA
5	68	1	1	1	1	1	165 224 020		DISTANZSCHEIBE	10X16X2,5	FLAT WASHER	RONDELLE	ARANDELA
5	69	1	1	1	1	1	165 245 120		ÖLDRUCKLEITUNG		OIL PRESSURE LINE	CONDUITE HUILE	TUBO ACEITE
5	88	1	1	1	1	1	125 180 200		KUPPLUNG KPL.		CLUTCH ASSY.	EMBRAYAGE CPL.	EMBRAGUE CPL.
5	89	1	1	1	1	1	170 223 111		KUPPLUNGSTROMMEL KPL.	3/8"	CLUTCH DRUM CPL.	TAMBOUR CPL.	TAMBOR CPL.
5	93	1	1	1	1	1	181 213 100		BREMSMECHANIK KPL.		BRAKING MECHANISM	MECANISME DE FREINAGE	MECANISMO DE FRENO
5	95	1	1	1	1	1	179 245 201		ÖLPUMPE KPL.		OIL PUMP CPL.	POMPE À HUILE CPL.	BOMBA DE ACEITE CPL.
5	96	1	1	1	1	1	125 245 100		ÖLSAUGLEITUNG KPL.		SUCTION LINE	CONDUITE HUILE CPL.	TUBO ACEITE CPL.
5	97	1	1	1	1	1	165 182 060		FÜHRUNGSSCHEIBE	10	FLAT WASHER	RONDELLE	ARANDELA
5	100	1	1	1	1		185 114 237		SCHILD HANDSCHUTZ		LABEL	PLAQUE	CALCOMANIA
5	100					1	980 115 200		SCHILD HANDSCHUTZ	J	LABEL	PLAQUE	CALCOMANIA
5	113	1	1	1	1	1	913 455 164		INNENSTERN SCHRAUBE	5,5X16	SCREW	VIS	TORNILLO
5	116	1	1	1	1	1	925 305 000		SCHNECKE	ø5/12x0,5	WASHER	RONDELLE	ARANDELA
5	217	2	2	2	2	2	165 184 020		ZUGFEDER	5	TENSION SPRING	RESSORT DE TRACTION	MUELLE DE TRACCIÓN
5	218	1	1	1	1	1	185 245 060		DRUCKFEDER	6	COMPRESSION SPRING	RESSORT	MUELLE
5	219	1	1	1	1	1	185 245 020		NIPPEL		NIPPLE	TETON DE TUYAU	BOQUILLA DE TUBO

EA3500S, EA3501S,
EA3502S, EA3503S,
MEA3502L

6

Motorträger, Kettenradchutz, Kettenspanner
Motor housing, sprocket guard, chain tensioner
Carter du moteur, protège-pignon, tendeur de chaîne
Cárter de motor, protector de piñon, tensor de la cadena

Makita

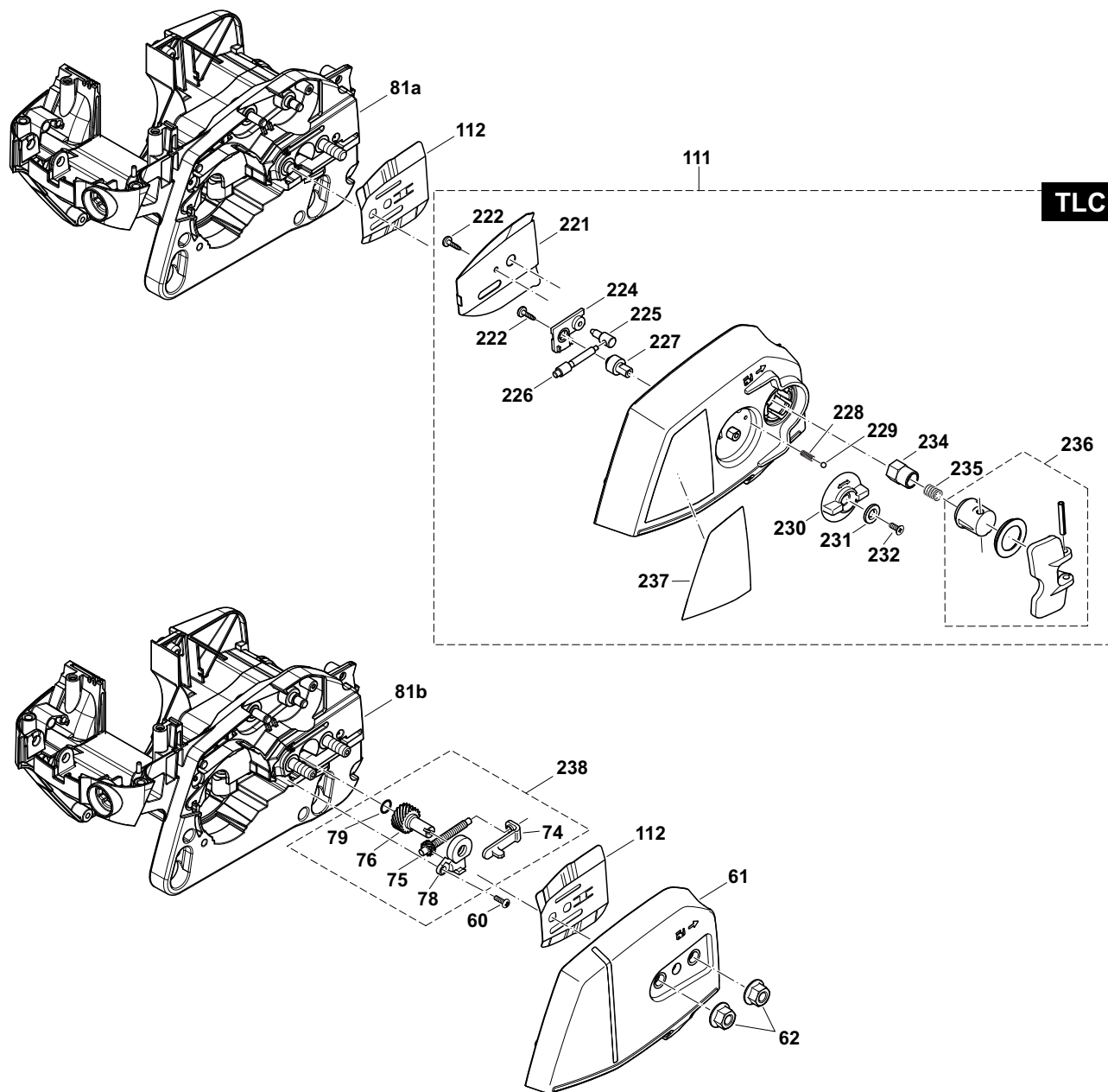

EA3500S, EA3501S,
EA3502S, EA3503S,
MEA3502L

6

Motorträger, Kettenradschutz, Kettenspanner
Motor housing, sprocket guard, chain tensioner
Carter du moteur, protège-pignon, tendeur de chaîne
Cárter de motor, protector de piñon, tensor de la cadena



Seite / Page	Pos.	EA3500S	EA3501S	EA3502S	EA3503S	MEA3502L	Teil-Nr. Part No. No. de pièce No. de pieza	Hinweise Notes Renseign. Nota	Bezeichnung	Spezifikation Specification	Description	Désignation	Denominación
6	60	4		4			165 888 120		SCHRAUBE	3X10 KS K	TAPPING SCREW	VIS	TORNILLO
6	61	1		1			165 213 600		KETTENRADSCHUTZ BLAU KPL.	BLUE	SPROCKET GUARD CPL.	PROTÈGE-PIGNON CPL.	PROTECTOR DE PIÑON CPL.
6	62	2		2			923 208 004		6KT-MUTTER	M8	HAXAGONAL NUT	ECROU HEXAGONAL	TUERCA HEXAGONAL
6	74	1		1			165 213 240		SPANNSCHLITTEN		TENSION SLIDE	COULISSEAU DE SERRAGE	CARRO DE TENSADO
6	75	1		1			185 213 230		KETTENSPANNSCHRAUBE	PROFI	TENSIONING SCREW	VIUS DE TENSION	TORNILLO DE TENSION
6	76	1		1			185 213 250		EINSTELLSCHRAUBE	PROFI	ADJUST SCREW	VIS DE REGLAGE	TORNILLO DE AJUSTE
6	78	1		1			185 213 270		GETRIEBEABDECKUNG	PROFI	TRANSMISSION COVER	REVÊTEMENT D' ENGRENAGES	CUBIERTA DE ENGRANAJES
6	79	1		1			185 213 410		O-RING	7X2	O-RING	ANNEAU TORIQUE	ANILLO OBTURADOR
6	81a		1		1	1	125 110 630		MOTORTRÄGER KPL. BLAU	BLUE, TLC INC. 70	ENGINE HOUSING COMPLETE	CARTER DU MOTEUR CPL.	CARTER DE MOTOR CPL.
6	81b		1		1		125 110 600		MOTORTRÄGER KPL. BLAU	BLUE INC. 70	ENGINE HOUSING COMPLETE	CARTER DU MOTEUR CPL.	CARTER DE MOTOR CPL.
6	111		1		1		125 213 660		KETTENRADSCHUTZ KPL. BLAU	BLUE, TLC	SPROCKET GUARD COMPLETE	PROTEGE-PIGNON CPL.	PROTECTOR DE PINON CPL.
6	111					1	125 213 670		KETTENRADSCHUTZ KPL. BLAU	BLUE, TLC (JP)	SPROCKET GUARD COMPLETE	PROTEGE-PIGNON CPL.	PROTECTOR DE PINON CPL.
6	112	1	1	1	1	1	195 213 120		KETTENFÜHRUNGSBLECH		GUIDE PLATE	TÔLE DE GUIDAGE	CHAPA DE GUÍA
6	221		1		1	1	165 213 310		KETTENFÜHRUNGSBLECH		GUIDE PLATE	TÔLE DE GUIDAGE	CHAPA DE GUÍA
6	222		2		2	2	320 266 007		GEWINDESCHNEIDSCHRAUBE	3,0X10	TAPPING SCREW BIND	VIS TARAUEUSE	TORNILLO DE ROSCA CORTANTE
6	224		1		1	1	170 213 670		KETTENSPANNABDECKUNG		COVER	COUVERCLE	CUBIERTA
6	225		1		1	1	170 213 660		SPANNMUTTER		TENSIONING NUT	ECROU DE TENSION	TUERCA DE TENSION
6	226		1		1	1	170 213 650		SPANNSCHRAUBE		TENSIONING SCREW	VIS DE TENSION	TORNILLO DE TENSION
6	227		1		1	1	170 213 710		ANTRIEBSRAD TLC		DRIVE WHEEL	ROUE D'ENTRAÎNEMENT	RUEDA DE IMPULSION
6	228		1		1	1	170 213 690		FEDER F.STAHLKUGEL	4	SPRING	RESSORT	MUELLE
6	229		1		1	1	170 213 770		STAHLKUGEL	4	LOCKING BALL	BILLE D ARRÊT	BOLA DE TOPE
6	230		1		1	1	226 213 340		SPANNRAD	40	TENSIONING WHEEL	ROUE DE SERRAGE	RUEDA TENSORA
6	231		1		1	1	924 204 020		SCHEIBE FÜR SPANNRAD	4X12X0,5	WASHER	DISQUE	ARANDELA
6	232		1		1	1	226 213 380		SCHRAUBE	(P+) M4X8	SCREW	VIS	TORNILLO
6	234		1		1	1	165 213 720		KLEMM-MUTTER	M8	HEX. NUT	ECROU DE CALAGE	TUERCA DE APRIETE
6	235		1		1	1	170 213 730		FEDER FÜR KLEMMMUTTER	8	SPRING	RESSORT	MUELLE
6	236		1		1	1	170 213 150		FLÜGELGRIFF KPL.		WING GRIP CPL.	POIGNEE À AILETTE CPL.	MANGO MARIPOSA CPL.
6	237		1		1		165 115 150		AUFKLEBER KETTENRADSCHUTZ	TLC	LABEL	PLAQUE	CALCOMANIA
6	237					1	125 115 135		AUFKLEBER KETTENRADSCHUTZ	TLC (JP)	LABEL	PLAQUE	CALCOMANIA
6	238	1		1			195 213 300		KETTENSPANNER KPL.	PROFI	CHAIN TENSIONER CPL.	TENDEUR DE CHAÎNE CPL.	SENSOR DE LA CADENA CPL.

EA3500S, EA3501S,
EA3502S, EA3503S,
MEA3502L

7

Vergaser
Carburetor
Carburateur
Carburador

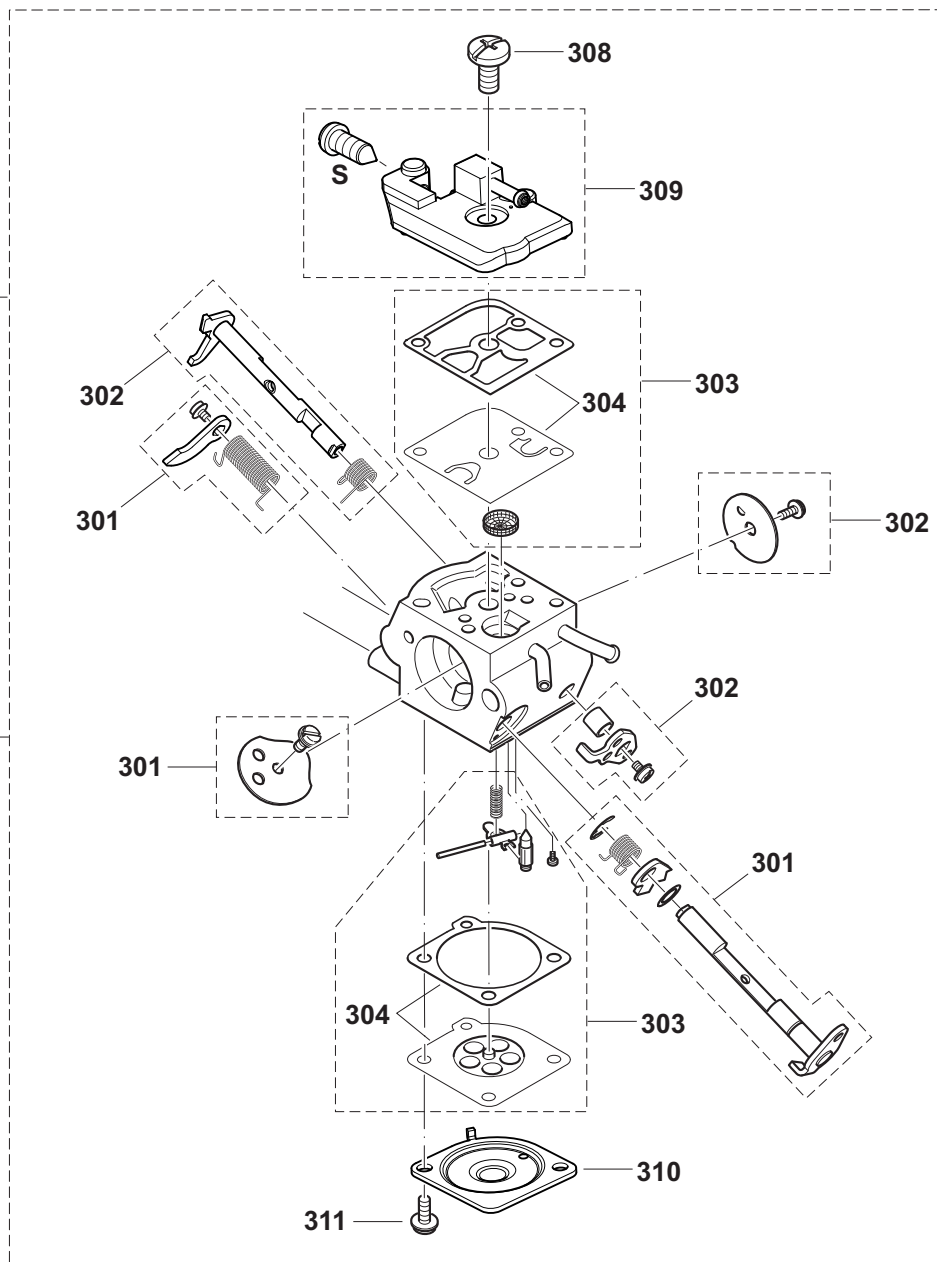
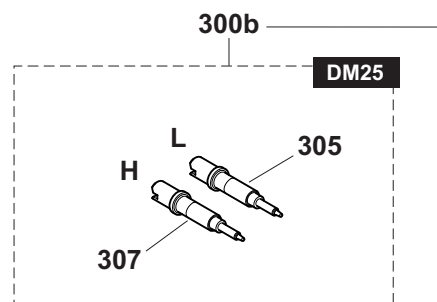
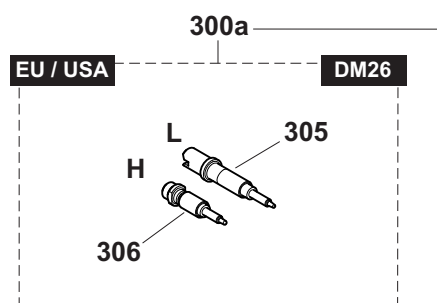

EA3500S, EA3501S,
EA3502S, EA3503S,
MEA3502L

7

Vergaser
Carburetor
Carburateur
Carburador



Seite / Page	Pos.	EA3500S	EA3501S	EA3502S	EA3503S	MEA3502L	Teil-Nr. Part No. No. de pièce No. de pieza	Hinweise Notes Renseign. Nota	Bezeichnung	Spezifikation Specification	Description	Désignation	Denominación
7	300a	1	1	1	1		125 153 200		VERGASER	DM26, DD - EU, USA (regulated market)	CARBURETOR	CARBURATEUR	CARBURADOR
7	300b	1	1	1	1	1	125 153 100		VERGASER	DM25 (non regulated market)	CARBURETOR	CARBURATEUR	CARBURADOR
7	301	1	1	1	1	1	125 153 580		REP.-SATZ CHOKEWELLE		KIT CHOKE SHAFT	JEU AXE CLAPET D'AIR	JUEGO EJE VÁLVULA AIRE
7	302	1	1	1	1	1	125 153 570		REP.-SATZ DROSSELWELLE		KIT THROTTLE SHAFT	JEU AXE CLAPET D'ÉTRANG.	JUEGO EJE VÁLVULA REG.
7	303	1	1	1	1	1	195 153 510		REPARATURSATZ VERGASER		REPAIR KIT	JEU DE RÉPARATION	JUEGO DE REPARAR
7	304	1	1	1	1	1	195 153 500		SATZ DICHTUNGEN / MEMBRANEN		SET GASKETS / DIAPHRAGM	JEU DE JOINT / MEMBRANE	JUEGO JUNTA / MEMBRANA
7	305	1	1	1	1	1	195 153 340		STELLSCHRAUBE	L	ADJUST SCREW	VIS DE REGLAGE	TORNILLO DE AJUSTE
7	306	1	1	1	1		195 153 350		STELLSCHRAUBE	H, DD - EU, USA (regulated market)	ADJUST SCREW	VIS DE REGLAGE	TORNILLO DE AJUSTE
7	307	1	1	1	1	1	195 153 470		STELLSCHRAUBE	H (non regulated market)	ADJUST SCREW	VIS DE REGLAGE	TORNILLO DE AJUSTE
7	308	1	1	1	1	1	038 153 360		SCHRAUBE FÜR PUMPENDECKEL		SCREW	VIS	TORNILLO
7	309	1	1	1	1	1	125 153 220		PUMPENDECKEL KPL.		PUMP COVER CPL.	COUVERCLE DE POMPE CPL.	TAPA DE BOMBA CPL.
7	310	1	1	1	1	1	195 153 360		MEMBRANDECKEL		DIAPHRAGM COVER	COUVERCLE DE MEMBRANE	TAPA DE MEMBRANA
7	311	2	2	2	2	2	001 153 019		SCHRAUBE		SCREW	VIS	TORNILLO

EA3500S, EA3501S,
EA3502S, EA3503S,
MEA3502L

8

Werkzeuge, Zubehör
Tools, accessories
Outils, accessoires
Herramientas, accesorios

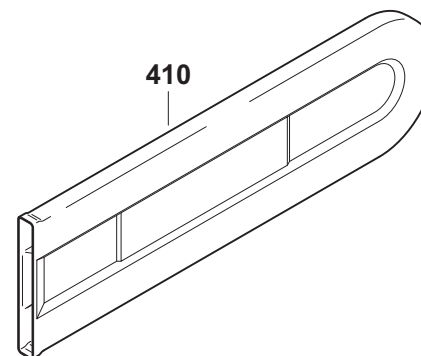
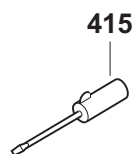
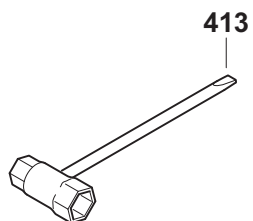
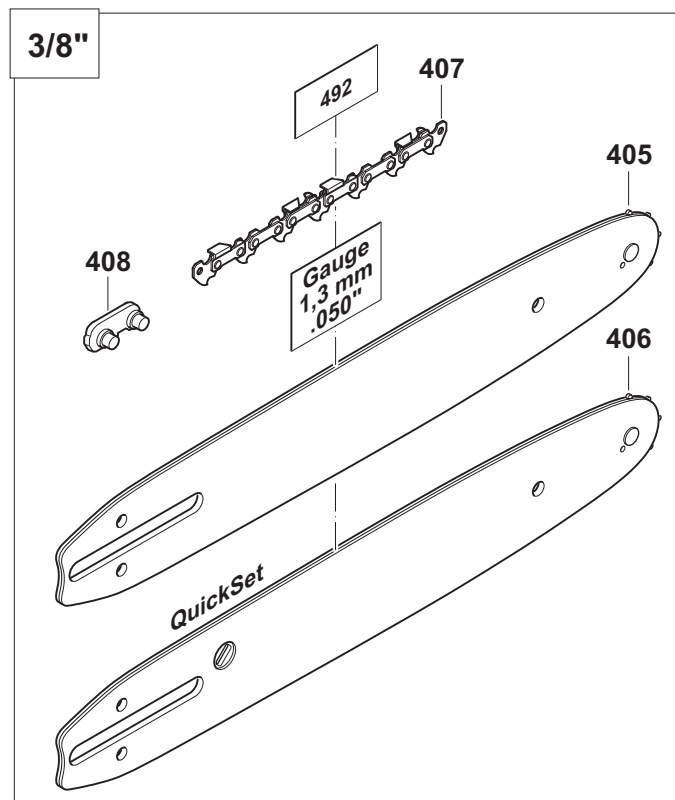

EA3500S, EA3501S,
EA3502S, EA3503S,
MEA3502L

8

Werkzeuge, Zubehör
Tools, accessories
Outils, accessoires
Herramientas, accesorios



Seite / Page	Pos.	EA3500S	EA3501S	EA3502S	EA3503S	MEA3502L	Teil-Nr. Part No. No. de pièce No. de pieza	Hinweise Notes Renseign. Nota	Bezeichnung	Spezifikation Specification	Description	Désignation	Denominación
8	405	1	1	1	1	1	442 030 661		STERNSCHIENE	3/8" .050" 30cm-12"	SPROCKET NOSE BAR	GUIDE À ÉTOILE	GUÍA CON ESTRELLA
8	405	1	1	1	1	1	442 035 661		STERNSCHIENE	3/8" .050" 35cm-14"	SPROCKET NOSE BAR	GUIDE À ÉTOILE	GUÍA CON ESTRELLA
8	405	1	1	1	1	1	442 040 661		STERNSCHIENE	3/8" .050" 40cm-16"	SPROCKET NOSE BAR	GUIDE À ÉTOILE	GUÍA CON ESTRELLA
8	406	1		1			442 030 061		STERNSCHIENE QUICKSET	3/8" .050" 30cm-12"	SPROCKET NOSE BAR	GUIDE À ÉTOILE	GUÍA CON ESTRELLA
8	407	1	1	1	1	1	531 492 646		SÄGEKETTE	3/8" .050" 30cm-12"	SAW CHAIN	CHAÎNE	CADENA
8	407	1	1	1	1	1	531 492 652		SÄGEKETTE	3/8" .050" 35cm-14"	SAW CHAIN	CHAÎNE	CADENA
8	407	1	1	1	1	1	531 492 656		SÄGEKETTE	3/8" .050" 40cm-16"	SAW CHAIN	CHAÎNE	CADENA
8	408	1	1	1	1	1	558 092 010		AUSSENLASCHE MIT NIET	3/8" .050"	TIE STRAP WITH RIVETS	ECLISSE EXTER. A. RIVETS	TIRA EXTER. CON REMACHE
8	410	1	1	1	1	1	952 010 630		KETTENSCHUTZ	30-35 cm	CHAIN PROTECTION	PROTECTION CHAÎNE	PROTECTOR DE CADENA
8	410	1	1	1	1	1	952 010 640		KETTENSCHUTZ	43 cm	CHAIN PROTECTION	PROTECTION CHAÎNE	PROTECTOR DE CADENA
8	413	1	1	1	1	1	941 713 160		KOMBISCHLÜSSEL	SW 13/16	UNIVERSAL WRENCH	CLÉ COMBINÉE	LLAVE DE BUJIA
8	415	1	1	1	1	1	944 340 001		SCHRAUBENDREHER		SCREWDRIVER	TOURNEVIS	DESTORNILLADOR

EA3500S, EA3501S,
EA3502S, EA3503S,
MEA3502L



	Zeichenerklärung	Key to symbols	Légende	Explicación de símbolos
=> 1999999 2000000 => 2003.04 => TI 2003/07 Acc. = { m Corr.	Produktion bis Serien-Nr. Neues Teil ab Serien-Nr. Neues Teil ab Jahr / Monat Siehe Technische Information Jahr / Nr. Zubehör (nicht im Lieferumfang) Keine Serienausführung, jedoch verwendbar Beinhaltet Positions-Nr. Meterware Druckfehlerberichtigung	Production to serial number New part from serial number New part from Year / Month See Technical Information Year / No. Accessories (not included in the delivery inventory) No standard execution, may be used Contains item number Sold by the meter Error correction	Production jusqu'à n° de série Nouvelle pièce à partir du n° de série Nouvelle pièce à partir de année / mois Voir information technique année / n° Accessoires (non compris dans la livraison) Aucune exécut. en série, cependant utilisable contient n° de numéro Au mètre Rectification d'erreurs	Producción hasta N° de serie Pieza nueva a partir de N° de serie Pieza nueva a partir de año / mes Véase inform. técnico año / N° Accesorios (no incluido en la extensión del suministro) No es de serie, pero sirve Contiene pos N° Por metro Fe de erratas
	Änderungen vorbehalten	Specifications subject to change without notice	Changements sans préavis	Mejoras constructivas sin previo aviso