

QCT97 (96071000100)

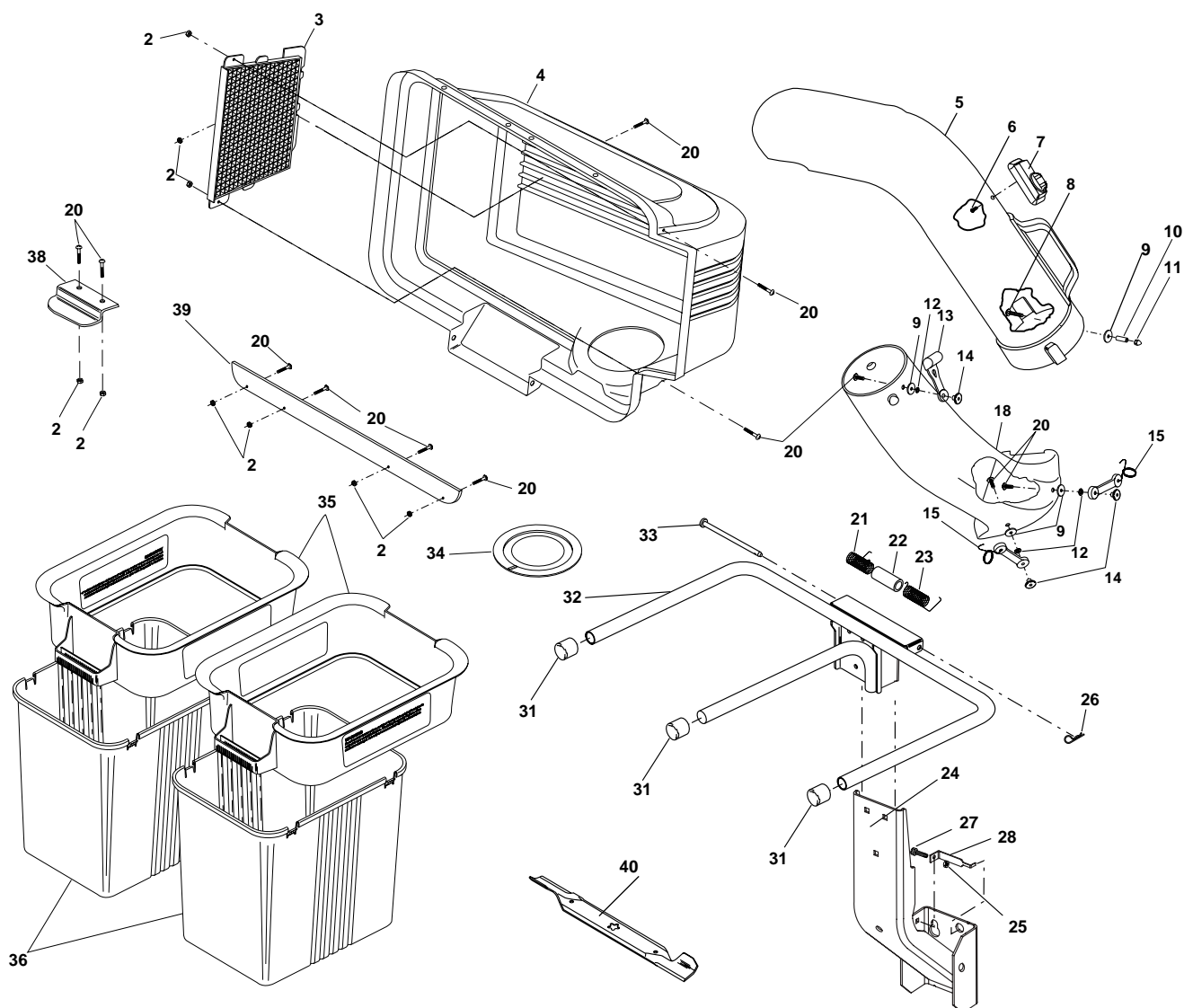

KEY NO.	PART NO.	DESCRIPTION
2	532 06 91-80	Nut, Crownlock #10-24
3	532 12 75-33	Screen, Cover
4	532 17 10-61	Cover Asm.(Incl. 3,38,39)
5	532 12 68-40	Chute, Upper
6	818 02 10-08	Screw, Special
7	532 13 09-33	Full Bag Indicator
8	532 08 71-75	Screw, #10-24 x 1-1/8
9	819 06 12-16	Washer 3/16x3/4x16 Ga.
10	532 00 72-06	Spacer, Split
11	532 06 08-67	Nut, Acorn #10-24
12	810 07 10-00	Washer, lock
13	532 10 98-08	Latch, Chute
14	532 12 50-04	Nut, Weld
15	532 16 07-93	Latch Assembly, Hook
18	532 19 25-74	Chute, Lower
20	871 08 10-10	Screw #10-24 x 5/8
21	532 13 27-96	Spring, Cover L.H. (black)

KEY NO.	PART NO.	DESCRIPTION
22	532 13 32-35	Spacer, Cover
23	532 13 29-83	Spring, Cover R.H. (gray)
24	532 18 09-23	Support Assembly
25	873 80 04-00	Locknut 1/4-20
26	532 12 46-70	Spring, Retainer
27	872 14 04-05	Bolt
28	532 17 97-45	Bracket, Stop
31	532 17 40-83	Plug, Tubing End
32	532 17 97-46	Bagger, Frame
33	532 19 27-86	Pin, Hinge
34	532 12 75-34	Gasket, Cover
35	532 18 32-86	Container, Top
36	532 12 95-86	Container, Bottom
38	532 13 08-95	Latch Handle, Cover
39	532 15 50-42	Strip, Reinforcement
40	532 13 84-97	Blade, High Lift
—	532 19 42-34	Owner's Manual