

# **ILLUSTRATED PARTS LIST**

**MODEL NO. 96041040700**

**CUSTOMER CATALOG NO. M165-97T CLASSIC  
CLASSIC**

**PRODUCT NO. 960 41 04-07**

**TRACTOR - - MODEL NO. M165-97T CLASSIC (96041040700), PRODUCT NO. 960 41 04-07  
DECALS 27**

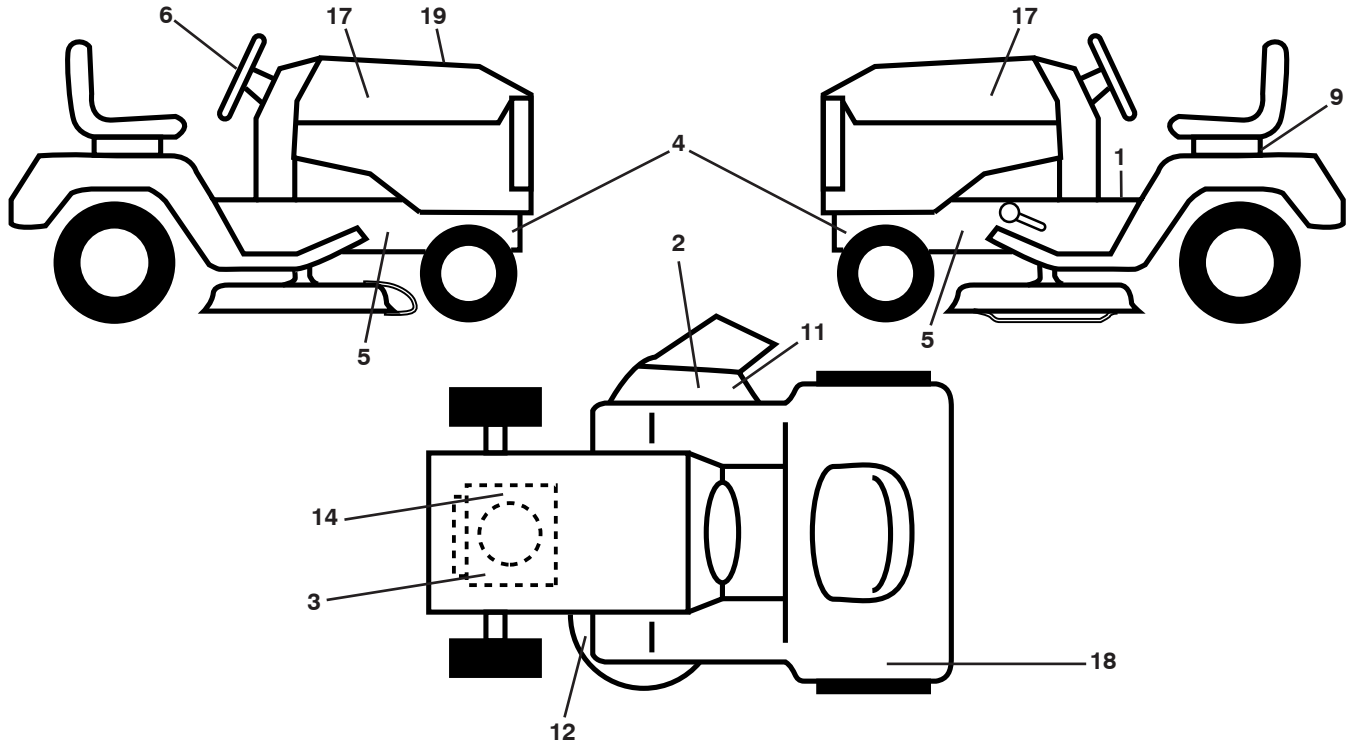

KEY NO.	PART NO.	DESCRIPTION
1	586 04 73-02	Decal, Operators
2	584 90 46-01	Decal, Deflect. Warning
3	581 57 97-01	Decal, Engine Warning
4	581 57 98-01	Decal, Warning Ser./Fire
5	581 57 96-01	Decal, Chassis Hot Muffler
6	501 49 43-01	Decal, Steering Wheel
9	532 14 50-05	Decal, Battery Dnge/Poi
11	581 57 92-01	Decal, Warning
12	581 58 00-03	Decal, Deck Sch.
14	581 57 97-01	Decal, Engine
17	581 09 12-01	Decal, Hood

KEY NO.	PART NO.	DESCRIPTION
18	591 16 36-01	Decal, Fender
19	591 17 13-01	Decal, Replacement
--	581 72 46-01	Decal, Drawbar
--	532 40 95-07	Pad, Footrest RH
--	532 40 95-05	Pad, Footrest, LH
--	581 72 48-01	Decal, Bypass
--	115 91 14-40	Manual Operator's (Euro)
--	115 91-15-50	Manual Operator's (Scan)
--	115 91-16-20	Manual Operator's (E-Bloc)
--	115 91-17-30	Manual Operator's (Baltic)

**WHEELS AND TIRES**

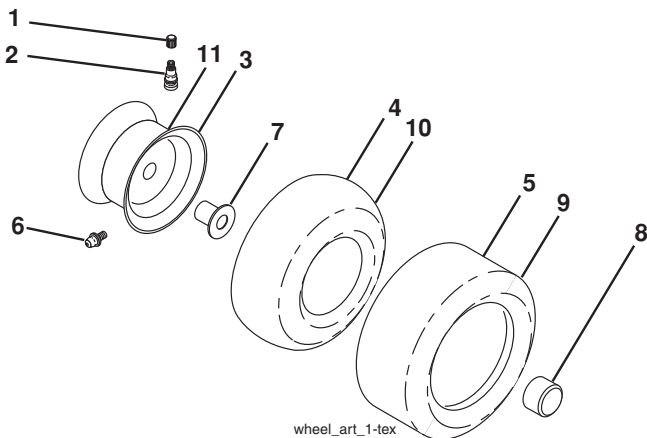

KEY NO.	PART NO.	DESCRIPTION
1	532 05 91-92	Cap Valve Tire
2	532 06 51-39	Stem Valve
3	532 12 51-21	Rim Asm 6" Front
4	532 05 99-04	Tube Front (Service Item Only)
5	532 10 62-22	Tire Front 15 x 6-6
6	532 12 49-57	Fitting Grease (Front Wheel Only)
7	532 12 49-59	Bearing Flange (Front Wheel Only)
8	532 19 32-68	Cap Axle 1 50 x 1 00
9	532 12 46-35	Tire Rear 18 x 8.5-8
10	532 12 49-26	Tube Rear (Service Item Only)
11	532 12 51-22	Rim Asm 8" Rear
--	532 14 43-34	Sealant, Tire (10 oz. Tube)

**NOTE:** All component dimensions given in U.S. inches  
1 inch = 25.4 mm

# TRACTOR - - MODEL NO. M165-97T CLASSIC (96041040700), PRODUCT NO. 960 41 04-07

## SCHEMATIC **38**

SCH11

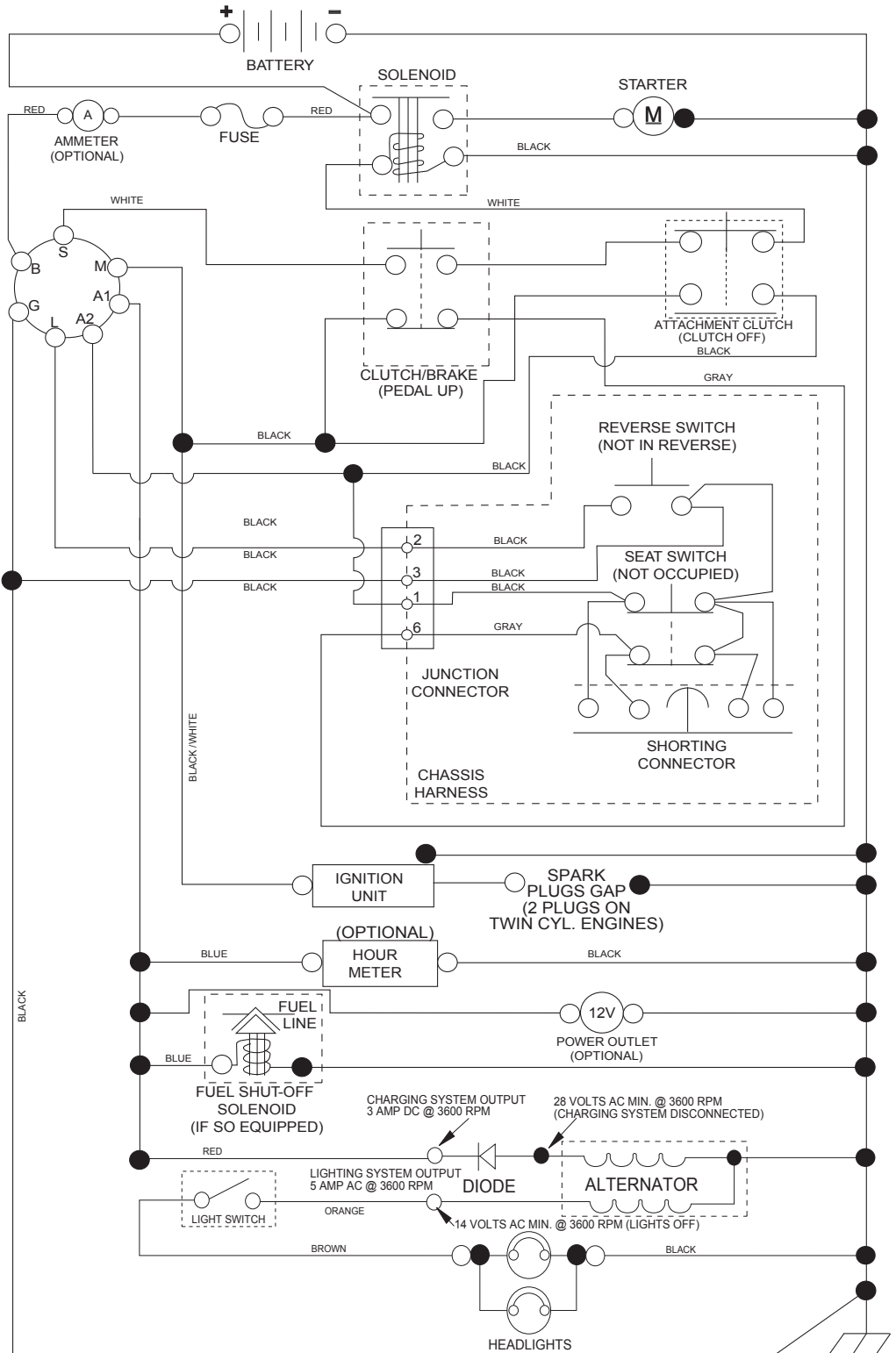

**NOTE**  
YOUR TRACTOR IS EQUIPPED WITH A SPECIAL ALTERNATOR SYSTEM. THE LIGHTS ARE NOT CONNECTED TO THE BATTERY, BUT HAVE THEIR OWN ELECTRICAL SOURCE. BECAUSE OF THIS, THE BRIGHTNESS OF THE LIGHTS WILL CHANGE WITH ENGINE SPEED. AT IDLE THE LIGHTS WILL DIM. AS THE ENGINE IS SPEEDED UP, THE LIGHTS WILL BECOME THEIR BRIGHTEST.

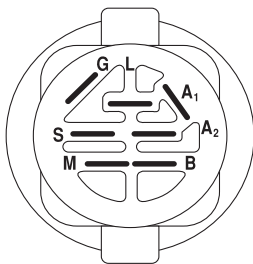

IGNITION SWITCH

POSITION	CIRCUIT	"MAKE"
OFF	M+G+A1	
RUN/OVERRIDE	B+A1	
RUN	B+A1	L+A2
START	B + S + A1	

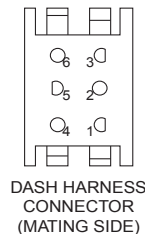
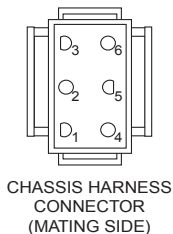

WIRING INSULATED CLIPS  
NOTE: IF WIRING INSULATED CLIPS WERE REMOVED FOR SERVICING OF UNIT, THEY SHOULD BE RE-INSTALLED TO PROPERLY SECURE YOUR WIRING.

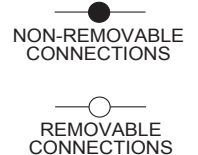

TRACTOR -- MODEL NO. M165-97T CLASSIC (96041040700), PRODUCT NO. 960 41 04-07  
 ELECTRICAL **32**

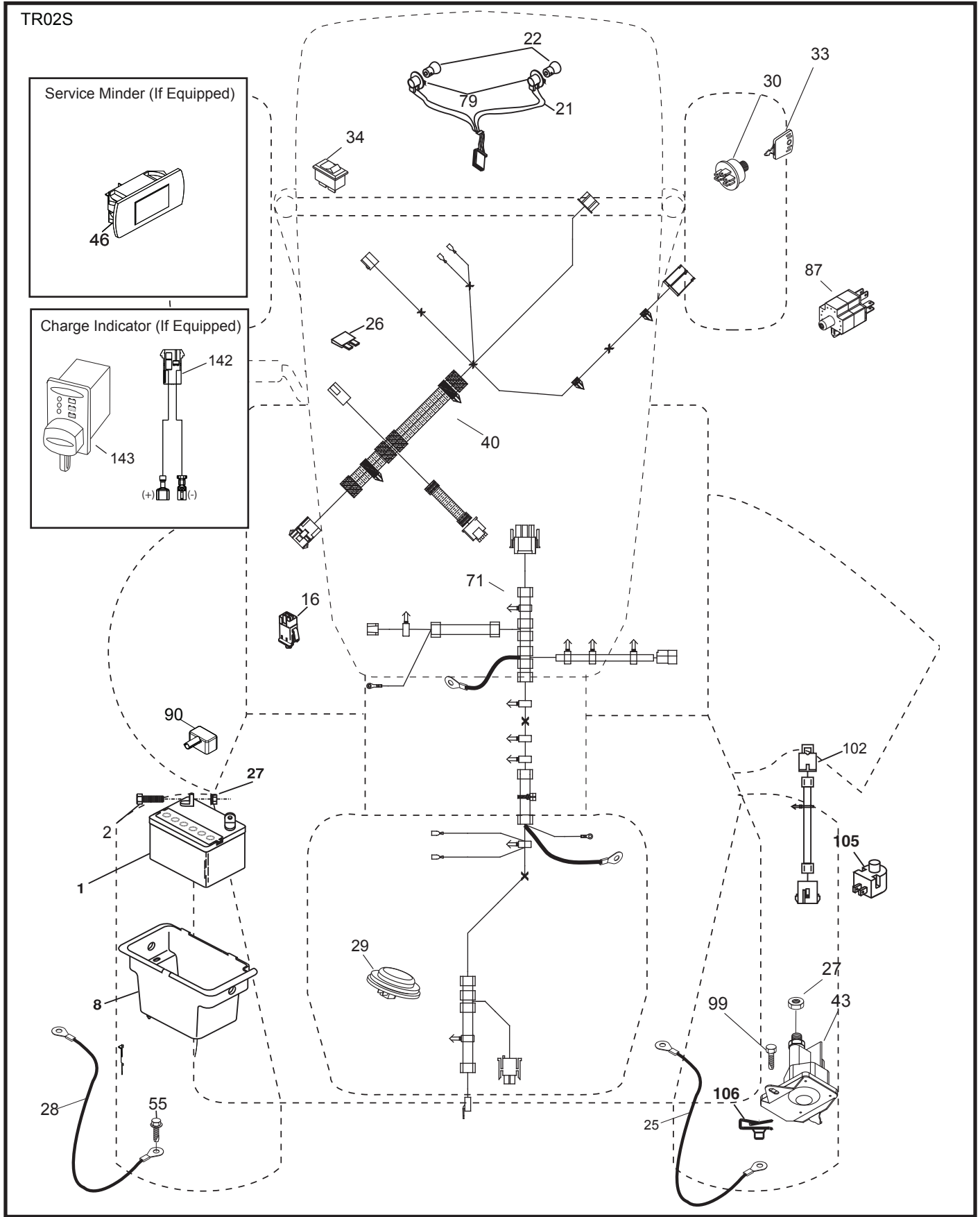

**TRACTOR - - MODEL NO. M165-97T CLASSIC (96041040700), PRODUCT NO. 960 41 04-07  
ELECTRICAL 32**

KEY NO.	PART NO.	DESCRIPTION
1	532 16 34-65	Battery
2	874 76 04-12	Bolt Hex Head 1/4-20 x 3/4
8	532 19 32-28	Box Battery
16	532 17 61-38	Switch Interlock Push-In
21	532 40 02-52	Harness Socket Light w/4152J
22	532 00 41-52	Bulb Light
25	581 49 80-01	Cable Starter
26	532 17 51-58	Fuse
27	873 51 04-00	Nut Keps Hex 1/4-20 unc
28	532 42 16-86	Cable,Ground
29	532 40 15-45	Switch, Seat
30	532 19 33-50	Switch, Ign
33	532 41 19-35	Key/Chain
34	532 11 07-12	Switch Light/Reset
40	581 02 31-01	Harness Ign. Dash
43	582 04 28-01	Solenoid
55	817 06 05-12	Screw Thdrol 5/16-18 x 3/4 TYTT
71	501 13 37-01	Harness Ign. Chassis
79	532 17 52-42	Socket Asm
87	532 19 78-02	Switch Interlock Clutch Cbl
90	532 43 53-95	Cover Terminal
99	817 67 04-12	Screw 1/4-20 x 3/4
102	581 02 34-01	Harness Pigtail VATR
105	532 40 75-68	Switch Reverse
106	532 17 48-14	Palnut 1/4 Lugs

**NOTE:** All component dimensions given in U.S. inches  
1 inch = 25.4 mm

TRACTOR - - MODEL NO. M165-97T CLASSIC (96041040700), PRODUCT NO. 960 41 04-07  
CHASSIS AND ENCLOSURES **39**

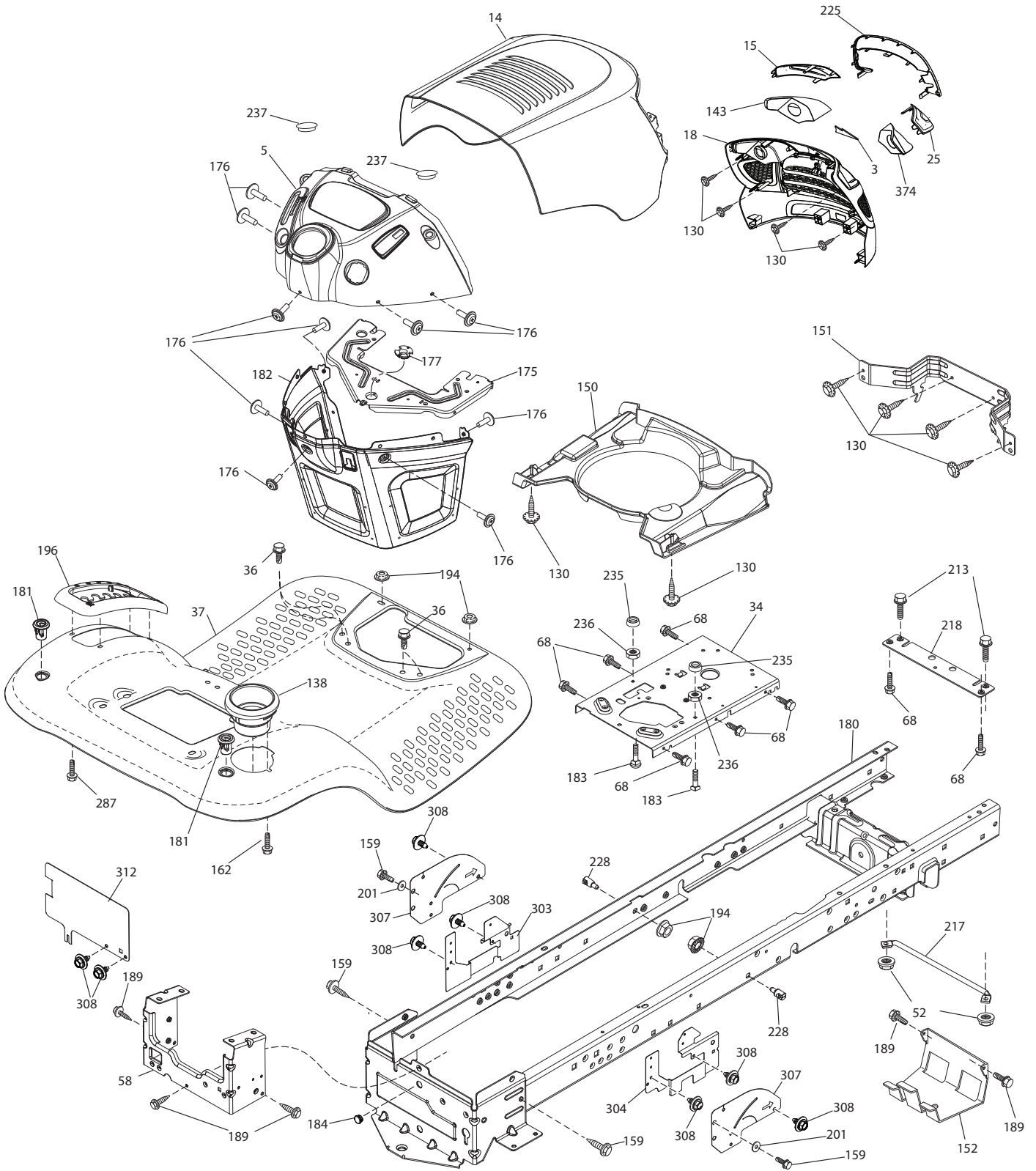

chassis-tex\_TEX LT PRED\_131

**TRACTOR - - MODEL NO. M165-97T CLASSIC (96041040700), PRODUCT NO. 960 41 04-07  
CHASSIS AND ENCLOSURES 39**

KEY NO.	PART NO.	DESCRIPTION
3	578 89 71-01	Emblem
5	532 42 57-72	Dash
14	532 40 95-98	Hood
15	581 05 58-01	Lens LH
18	581 05 57-01	Grille
25	581 05 59-01	Lens RH
34	580 91 08-01	Plate Engine
36	817 06 05-12	Screw 5/16-18 x 3/4
37	532 42 07-96	Fender
52	873 68 05-00	Nut Crown Lock 5/16
58	532 41 22-80	Drawbar
68	817 49 05-08	Screw THDROL 5/16-18 x 1/2
130	532 41 63-58	Screw
138	532 40 97-30	Cupholder
143	581 05 60-01	Insert Reflection LH
150	532 40 83-10	Air Duct
151	532 18 75-68	Bracket Pivot
152	532 19 95-35	Shield Browning
159	817 00 06-12	Screw 3/8-16 x 3/4
162	532 14 24-32	Screw 1/4 x 1/2
175	532 19 94-72	Crossmember
176	532 40 07-76	Screw 10-24 x 5/8
177	532 19 52-28	Bushing Steering
180	532 41 50-63	Chassis
181	532 40 47-96	Bushing Mtg. Fender Crgo
182	532 40 71-76	Dash Lower
183	874 52 05-20	Bolt 5/16-18 x 1-1/4
184	587 55 41-01	Plug

KEY NO.	PART NO.	DESCRIPTION
189	817 00 05-12	Screw 5/16-18 x 3/4
194	873 90 05-00	Nut Lock Hex Flange 5/16-18
196	532 41 45-81	Console Asm. Deck Lift
201	819 13 20-16	Washer 13/32 x 1-1/4 x 16 Ga.
213	874 76 05-12	Bolt 5/16-18 x 3/4
217	532 40 91-67	Rod Pivot Hood
218	532 19 63-95	X-Piece Hood Stop
225	581 05 62-01	Trim Ring
228	532 19 51-61	Stud Fastener
235	532 40 61-29	Spacer Fender
236	873 93 05-00	Nut Lock 5/16-18 unc
237	532 40 37-04	Plug Mount Cargo
287	817 60 04-06	Screw Hex
303	587 49 34-02	Shield Chassis French LH
304	587 86 51-02	Shield Chassis French RH
307	587 49 46-01	Shield Upper
308	532 17 18-77	Bolt 5/16-18 unc x 3/4
312	587 49 30-02	Shield Drawbar
374	581 05 60-02	Insert Reflection RH

**NOTE:** All component dimensions given in U.S. inches  
1 inch = 25.4 mm

TRACTOR - - MODEL NO. M165-97T CLASSIC (96041040700), PRODUCT NO. 960 41 04-07  
DRIVE **40**

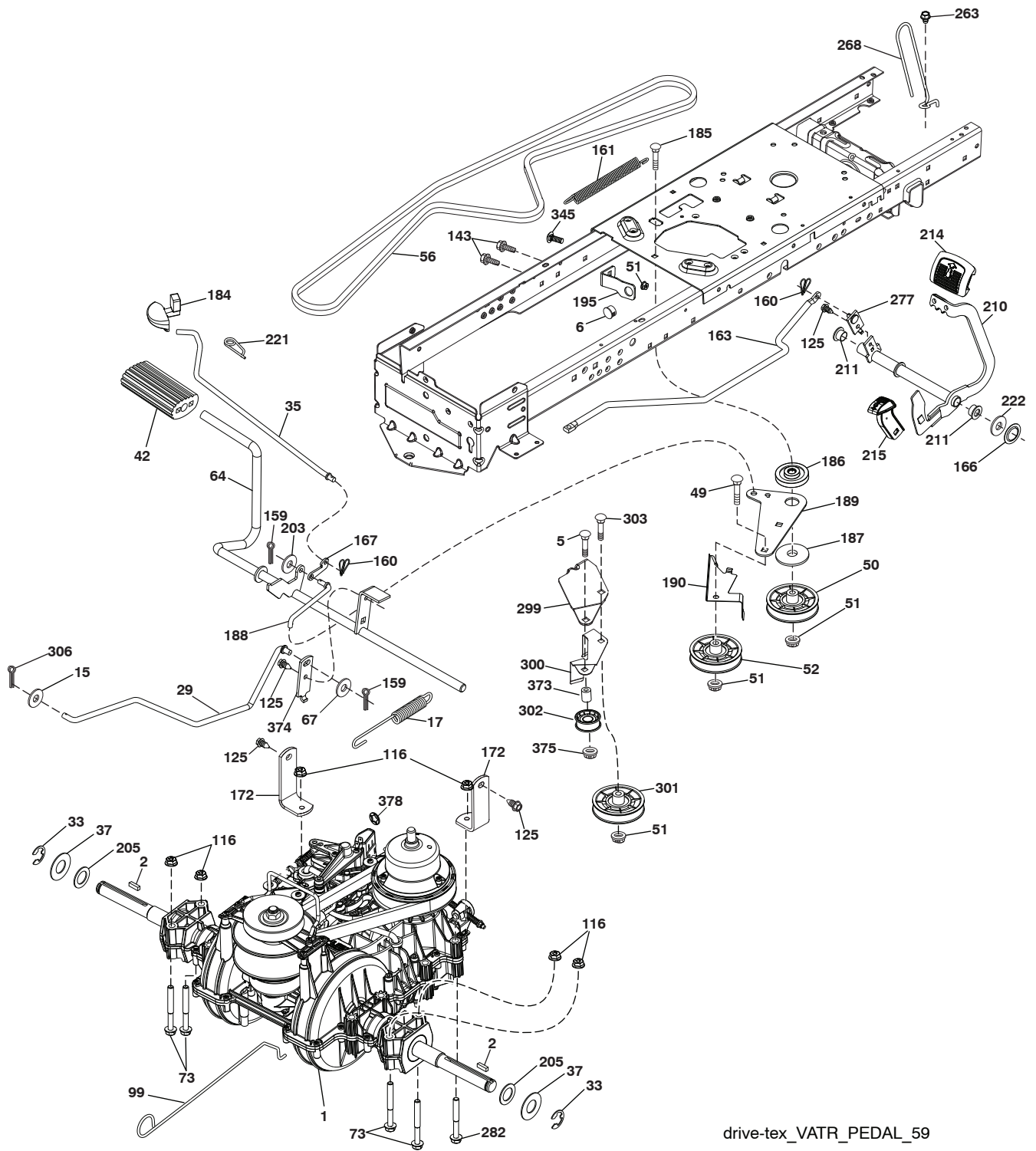

drive-tex\_VATR\_PEDAL\_59



**TRACTOR - - MODEL NO. M165-97T CLASSIC (96041040700), PRODUCT NO. 960 41 04-07  
DRIVE 40**

KEY NO.	PART NO.	DESCRIPTION	KEY NO.	PART NO.	DESCRIPTION
1	---	Transaxle, Variator SD Pedal (587884401) (Order parts from transaxle manufacturer.)	186	532 19 43-21	Spacer Retainer
2	532 12 35-83	Key Square	187	819 13 32-10	Washer 13/32 x 2 x 10 ga
5	874 76 06-36	Bolt Hex HS 3/8-16 unc x 2-1/4	188	582 21 70-01	Link Clutch Ground Drive, Long
6	532 12 40-28	Bushing Snap	189	532 19 43-17	Bellcrank Ground Drive
15	819 13 13-16	Washer 13/32 x 13/16 x 16 Ga.	190	532 19 43-18	Keeper. Bellcrank
17	501 48 71-01	Spring, Brake	195	581 50 46-01	Bracket Brake
29	584 82 31-02	Rod, Brake	203	819 11 11-16	Washer 11/32 x 11/16 x 16
33	812 00 00-01	Ring E	205	532 12 17-48	Washer 25/32 x 1-5/8 16 Ga.
35	532 40 10-31	Rod, Brake, Park	210	588 92 10-01	Weldment Pedal Variator
37	532 18 89-67	Washer .793 x 1.637 x 060	214	532 42 12-63	Pedal Forward
42	532 12 48-72	Cover, Foot Pedal	215	532 44 82-54	Pad Pedal Reverse
49	872 11 06-14	Bolt 3/8-16 unc	211	532 12 01-83	Bearing Nylon
50	532 19 43-27	Idler Flat	221	532 40 31-87	Retainer Spring
51	873 90 06-00	Nut Lock	222	879 21 20-10	Washer Flat
52	532 19 43-26	Idler V-Groove	263	817 00 06-12	Screw
56	581 60 38-01	V-Belt, Drive	268	532 18 24-02	Guard.Muffler
64	589 67 14-01	Subasm. Shaft Pedal Brake	277	532 44 85-00	Subasm. Link Rocker Pedal
67	582 58 01-01	Washer Nylon 13/32 x 13/16 x .109	282	874 49 05-48	Bolt Hex 5/16-18x
73	874 49 05-44	Bolt Hex 5/16-18 x 3.75	299	532 41 56-83	Bracket Mount
99	532 43 59-35	Rod Bypass	300	532 41 56-81	Keeper Idler
116	873 90 05-00	Nut Lock Hex Flange 5/16-18	301	532 41 56-80	Pulley Idler Groove
125	817 00 05-12	Screw 5/16-18 x 3/4	302	581 42 05-01	Puller Idler Flat
143	817 49 05-08	Screw Thdrol 5/16-18 x 1/2 TYTT	303	872 11 06-18	Bolt
159	876 02 04-12	Pin Cotter 1/8 x 3/4	306	876 02 04-16	Pin Cotter
160	532 16 94-84	Retainer Clip	345	872 11 06-06	Bolt RDHD
161	532 10 57-09	Spring, Return, Clutch	373	581 46 18-01	Spacer Idler
163	587 84 79-02	Rod Control	374	581 47 52-01	Arm Control Brake
166	532 42 91-64	Nut Push .625	375	873 68 06-00	Nut Crownlock 3/8-16 unc
167	532 40 52-57	Latch Brake Parking	378	584 28 77-01	Nut Push 8 mm
172	583 97 42-02	Strap Torque Variator			
184	532 41 14-84	Handle Park Brk.			
185	872 11 06-22	Bolt 3/8-16 unc x 2-3/4			

**NOTE:** All component dimensions given in U.S. inches.  
1 inch = 25.4 mm

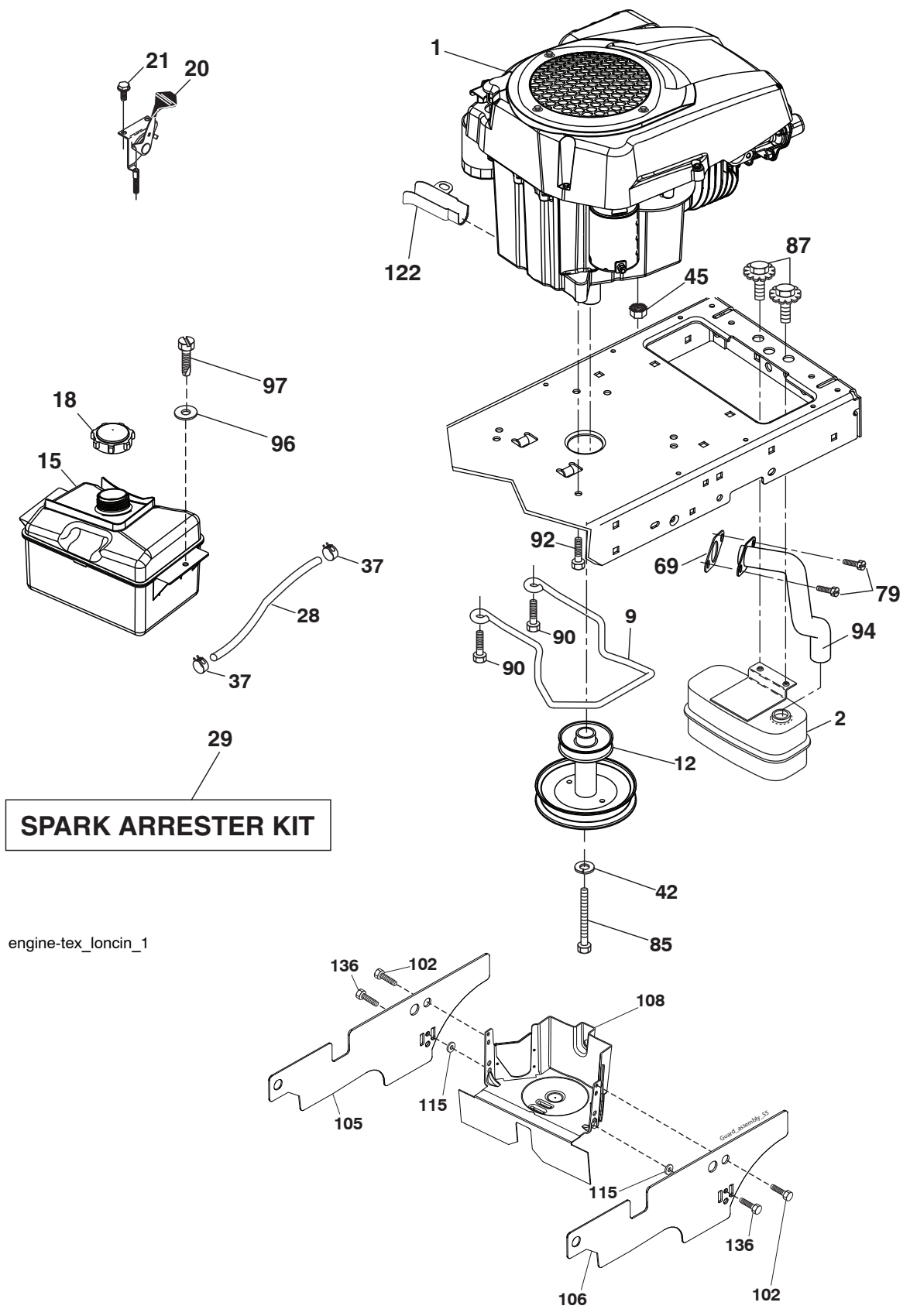

engine-tex\_loncin\_1

**TRACTOR - - MODEL NO. M165-97T CLASSIC (96041040700), PRODUCT NO. 960 41 04-07  
ENGINE 24**

<b>KEY NO.</b>	<b>PART NO.</b>	<b>DESCRIPTION</b>
1	— — — — —	Engine McCulloch LC1P92F-1 (590825701)
2	532 18 86-55	Muffler
9	501 83 26-02	Keeper Belt Engine
12	586 47 85-01	Pulley Engine
15	581 28 99-01	Tank Fuel 1.5
18	532 43 02-20	Cap Asm
20	532 18 38-97	Control Throttle
21	532 41 63-58	Screw #10 x .750 BOS Thread
28	532 13 70-40	Fuel Line
29	532 13 71-80	Spark Arrester Kit
37	532 12 34-87	Clamp Hose
42	539 99 02-47	Washer SLW STD 7/16
45	873 51 04-00	Nut Keps Hex 1/4-20 unc
69	590 86 35-01	Gasket
79	532 18 39-06	Screw Socket Head 5/16-18 x 1
85	501 60 65-01	Bolt Hex 7/16-20 x 4 Gr. 5
87	532 17 18-77	Bolt 5/16-18 unc x 3/4 w/SEMS
90	817 00 06-16	Screw 3/8-16 x 1
92	817 12 06-16	Screw 3/8-16 x 1 SMGL Tap/R
94	590 86 47-01	Tube Exhaust Loncin
96	819 09 14-16	Washer 9/32 x 7/8 x 16 Ga.
97	817 67 04-12	Screw Hexwsh Thdrol 1/4-20 x 3/4
102	817 00 05-12	Screw 5/16-18 x 3/4
105	501 26 72-02	Shield Side LH
106	501 26 82-09	Shield Side RH
108	587 17 95-09	Cover Eng. Pulley w/SHLD 38", 42"
115	532 43 17-61	Palnut #10
122	532 42 19-22	Extension Drain Oil
136	532 42 17-56	Screw, #10 0.500, BOS

**NOTE:** All component dimensions given in U.S. inches  
1 inch = 25.4 mm

TRACTOR - - MODEL NO. M165-97T CLASSIC (96041040700), PRODUCT NO. 960 41 04-07  
STEERING ASSEMBLY **41**

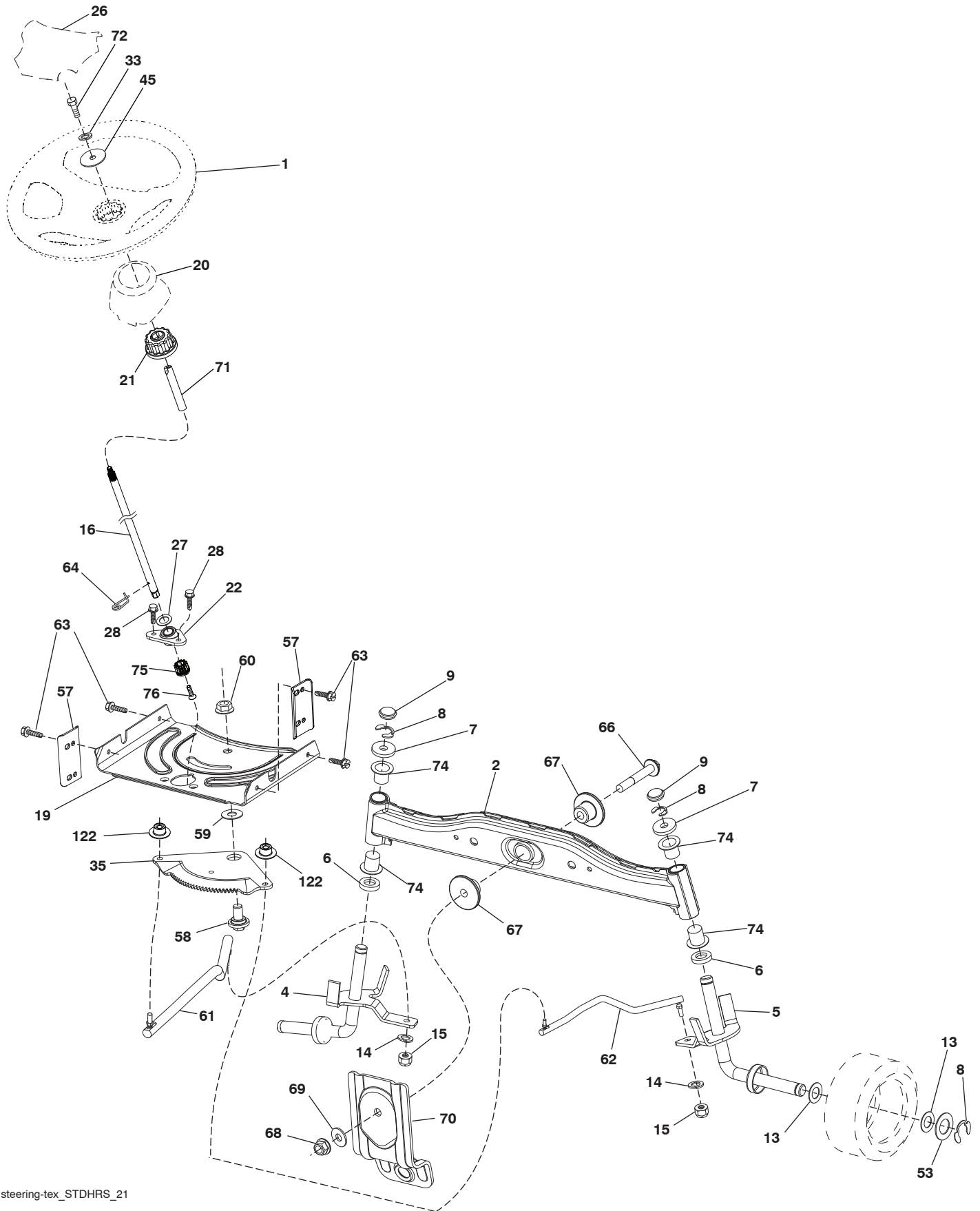

steering-tex\_STDHRS\_21

**TRACTOR - - MODEL NO. M165-97T CLASSIC (96041040700), PRODUCT NO. 960 41 04-07  
STEERING ASSEMBLY 41**

<b>KEY NO.</b>	<b>PART NO.</b>	<b>DESCRIPTION</b>
1	532 42 45-43	Wheel, Steering
2	532 41 81-68	Axle Asm., Front
4	532 40 30-87	Spindle Asm., LH
5	532 40 30-88	Spindle Asm., RH
6	532 12 49-31	Bearing, Race Thrust Hardened
7	532 12 17-48	Washer 25/32 x 1-5/8 x 16 Ga.
8	812 00 00-29	Ring, Klip #T5304-75
9	532 12 12-32	Cap, Spindle
13	532 12 17-49	Washer, 25/32 x 1-1/4 x 16 Ga.
14	539 99 01-18	Washer, SLW ZD 3/8
15	873 54 06-00	Nut, Crown Lock 3/8-24 unf
16	585 86 92-02	Steering Shaft
19	532 19 47-29	Plate Steering
20	532 40 97-63	Boot, Steering
21	532 18 67-37	Adapter, Wheel Steering
22	585 02 98-02	Bearing
26	532 42 46-91	Insert, Wheel Steering
27	819 21 16-16	Washer 21 x 32 x 1 x 16 Ga.
28	817 00 06-12	Screw 3/8-16 x 3/4
33	539 99 01-87	Washer Lock 5/16
35	532 19 47-32	Gear, Sector Plate
45	819 11 38-12	Washer 11/32 x 3/8 x 12 Ga.
53	532 18 89-67	Washer Hardened .793 x 1.637 x .060
57	532 40 74-65	Bracket Upstop
58	532 19 47-47	Bolt Shoulder Sector Pivot CFM
59	532 19 47-48	Washer Thrust Sector Steering
60	873 97 10-00	Nut Flange Lock 5/8-11
61	532 19 47-40	Draglink, LH
62	532 19 47-41	Draglink, RH
63	817 00 05-12	Screw 5/16-18 x 3/4
64	532 19 98-49	Retainer Clip Spring Steering
66	871 02 07-48	Bolt Hex Fghd 7/16-14 x 3 Serr
67	532 19 47-37	Bushing PM Front Axle
68	873 90 07-00	Nut Lock Flange 7/16-14 Gr. 5
69	532 19 91-62	Washer 1.5 x .505 x .118
70	585 33 88-01	Bracket Deck Susp. Front
71	532 19 07-52	Shaft Extension Steering
72	532 42 89-82	Bolt Fin Hex 5/16-18 x 3/4 w/Patch
74	532 12 49-37	Bearing
75	580 68 37-01	Pinion
76	580 68 36-01	Screw Head Sock
122	532 44 49-62	Cap Gear

**NOTE:** All component dimensions given in U.S. inches  
1 inch = 25.4 mm

TRACTOR - - MODEL NO. M165-97T CLASSIC (96041040700), PRODUCT NO. 960 41 04-07  
MOWER DECK 44

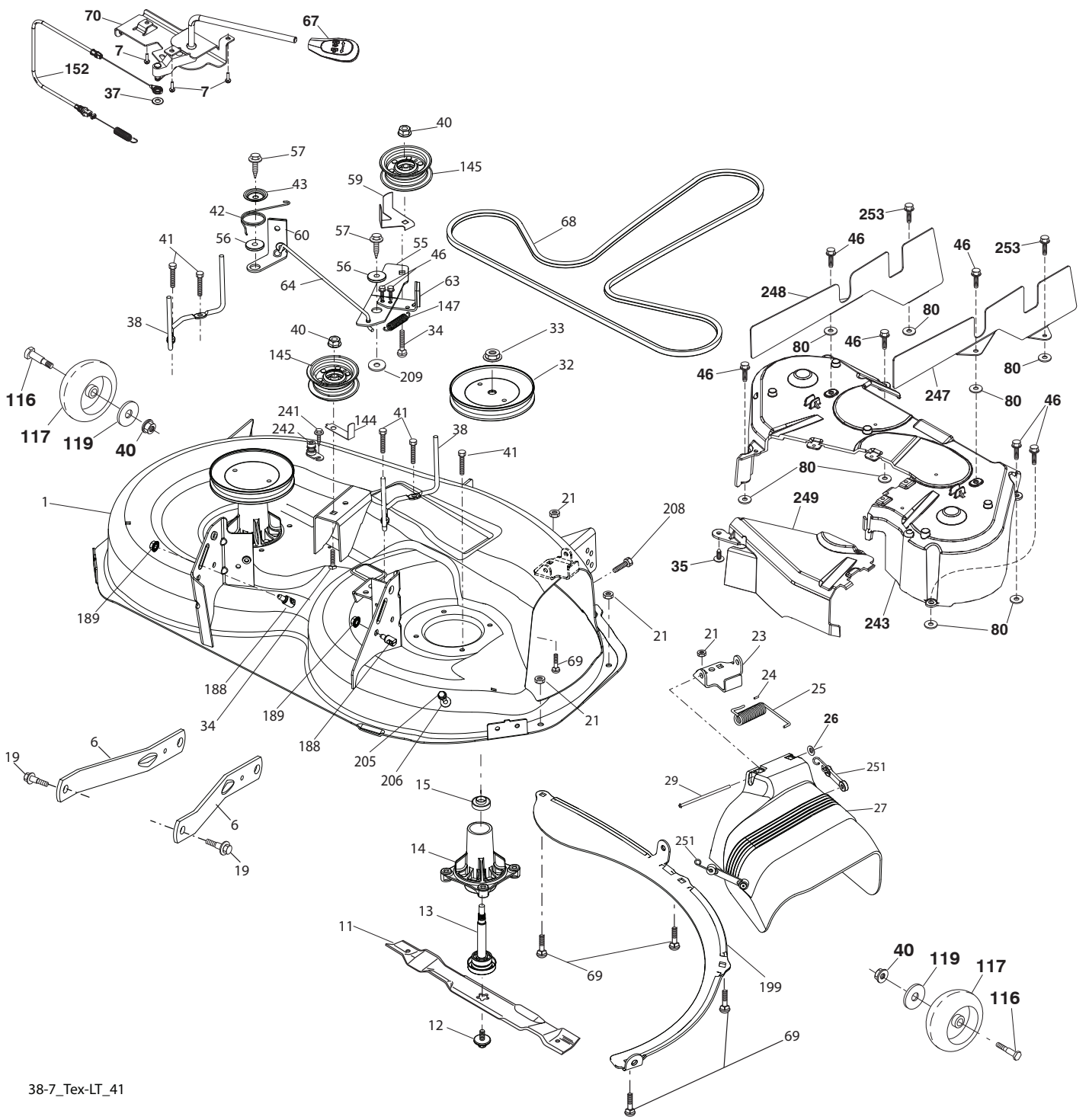

38-7\_Tex-LT\_41

**TRACTOR - - MODEL NO. M165-97T CLASSIC (96041040700), PRODUCT NO. 960 41 04-07  
MOWER DECK 44**

KEY NO.	PART NO.	DESCRIPTION	KEY NO.	PART NO.	DESCRIPTION
1	587 77 18-03	Mower Housing	69	872 14 05-05	Bolt
6	532 19 51-86	Arm Suspension	70	532 40 12-46	Clutch Asm. Manual
7	532 41 63-58	Screw #10 x 0.750 BOS Thread	80	532 42 30-62	Palnut 1/4
11	581 11 63-01	Blade 38" 2N1 Premium	116	532 12 48-42	Bolt
12	584 30 93-01	Screw 7/16-20 x 1 Hx	117	589 52 74-01	Wheel Gauge Rally
13	587 25 65-01	Shaft Assembly, Mandrel	119	819 12 14-14	Washer P15-105E
14	532 18 72-81	Housing, Mandrel	144	532 19 34-14	Keeper Belt
15	585 32 39-01	Bearing, Mandrel	145	532 19 31-97	Pulley Idler
19	532 19 65-39	Bolt, Shoulder	147	532 40 18-72	Spring Return
21	873 68 05-00	Nut, Crownlock 5/16-18 unc	152	532 43 51-11	Manual Clutch Cable
23	532 19 25-57	Bracket, Deflector	188	532 19 51-61	Stud Fastener
24	532 10 53-04	Cap, Sleeve	189	873 90 05-00	Nut Lock Hex Flange
25	532 19 70-26	Spring, Torsion, Deflector	199	532 40 00-95	Baffle Vortex
26	532 11 04-52	Nut, Push	205	817 49 04-16	Screw 1/4-20 x 1
27	532 40 16-18	Shield, Deflector	206	819 09 14-16	Washer 9/32 x 7/8 x 16 Ga.
29	532 13 14-91	Rod, Hinge	208	817 67 06-08	Screw THRDL
32	532 19 97-89	Pulley, Mandrel	209	819 13 32-10	Washer 13/32 x 2 x 10
33	532 40 02-34	Nut, Toplock, Flanged	241	532 15 29-27	Screw TT #10-32.5 3/8
34	872 11 06-12	Bolt Carr. Sh. 3/8-16 x 1-1/2 Gr. 5	242	532 41 55-98	Port Washout
35	532 13 38-35	Fastener	243	532 40 65-10	Cover Deck 38
37	819 13 13-16	Washer	247	532 43 02-59	Shield Deck LH
38	532 19 95-41	Keeper Belt LH Mandrel	248	532 43 02-58	Shield Deck RH
40	873 90 06-00	Nut, Lock Flg. 3/8-16 unc	249	532 40 65-14	Cover Cable Clutch
41	584 95 39-01	Bolt Hex Wshr	251	532 43 60-87	Kit Bungee
42	532 19 84-10	Spring Torsion Brake	253	532 42 73-50	Rivet
43	532 19 72-56	Spring Torsion Retainer	--	587 25 33-01	Mandrel Assembly (Includes housing (key# 14), shaft assembly (key# 13), and bearing (key# 15) only - pulley/nut/washer and blade bolt/washers not included.)
46	532 13 77-29	Screw 1/4 - 20 x 5/8	--	532 43 37-41	Replacement Mower, Complete
55	532 19 72-49	Arm, Idler			
56	532 19 90-92	Spacer, Retainer			
57	817 00 06-16	Screw 3/8-16 x 1			
59	532 14 10-43	Guard, Tuv. Idler			
60	532 19 94-71	Arm Brake Mower			
63	532 19 94-70	Arm Brake Mower			
64	532 19 97-90	Link Brake			
67	532 40 30-12	Handle Clutch Cable			
68	532 40 83-81	V-Belt			

**NOTE:** All component dimensions given in U.S. inches  
1 inch = 25.4 mm

**TRACTOR - - MODEL NO. M165-97T CLASSIC (96041040700), PRODUCT NO. 960 41 04-07  
MOWER LIFT 45**

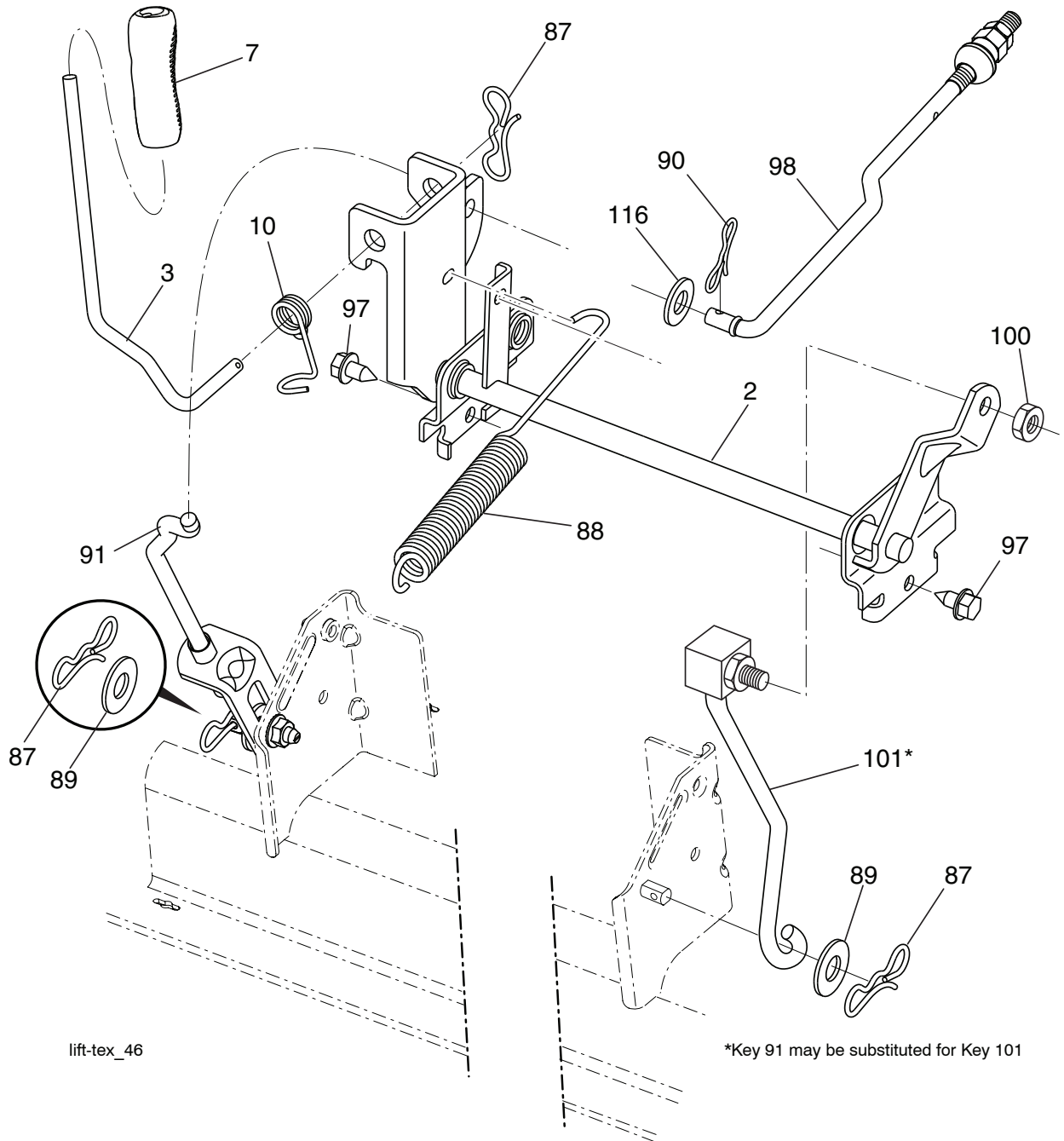

KEY NO.	PART NO.	DESCRIPTION
2	532 42 20-27	Shaft Asm., Lift
3	532 19 52-31	Lever Asm., Lift RH
7	580 96 23-01	Grip, Lever
10	532 19 63-14	Spring Torsion
87	532 19 42-09	Pin Cotter 7/16 Bow Tie Lock
88	532 41-07-10	Spring Lift Assist
89	819 19 19-12	Washer Clear Zinc
90	532 19 42-08	Pin Cotter 5/16 Bow Tie Lock

KEY NO.	PART NO.	DESCRIPTION
91	532 19 51-81	Link Lift Susp Mower Rear
97	817 00 06-12	Screw 3/8-16 x .75
98	532 19 52-70	Link Lift Susp. Front Mower
100	873 93 06-00	Nut Centerlock 3/8-16
101	532 40-70-03	Link Asm. Lift FXD
116	819 15 15-16	Washer 15/32 x 15/16 x 16 Ga.

**NOTE:** All component dimensions given in U.S. inches  
1 inch = 25.4 mm



**TRACTOR - - MODEL NO. M165-97T CLASSIC (96041040700), PRODUCT NO. 960 41 04-07  
SEAT ASSEMBLY 42**

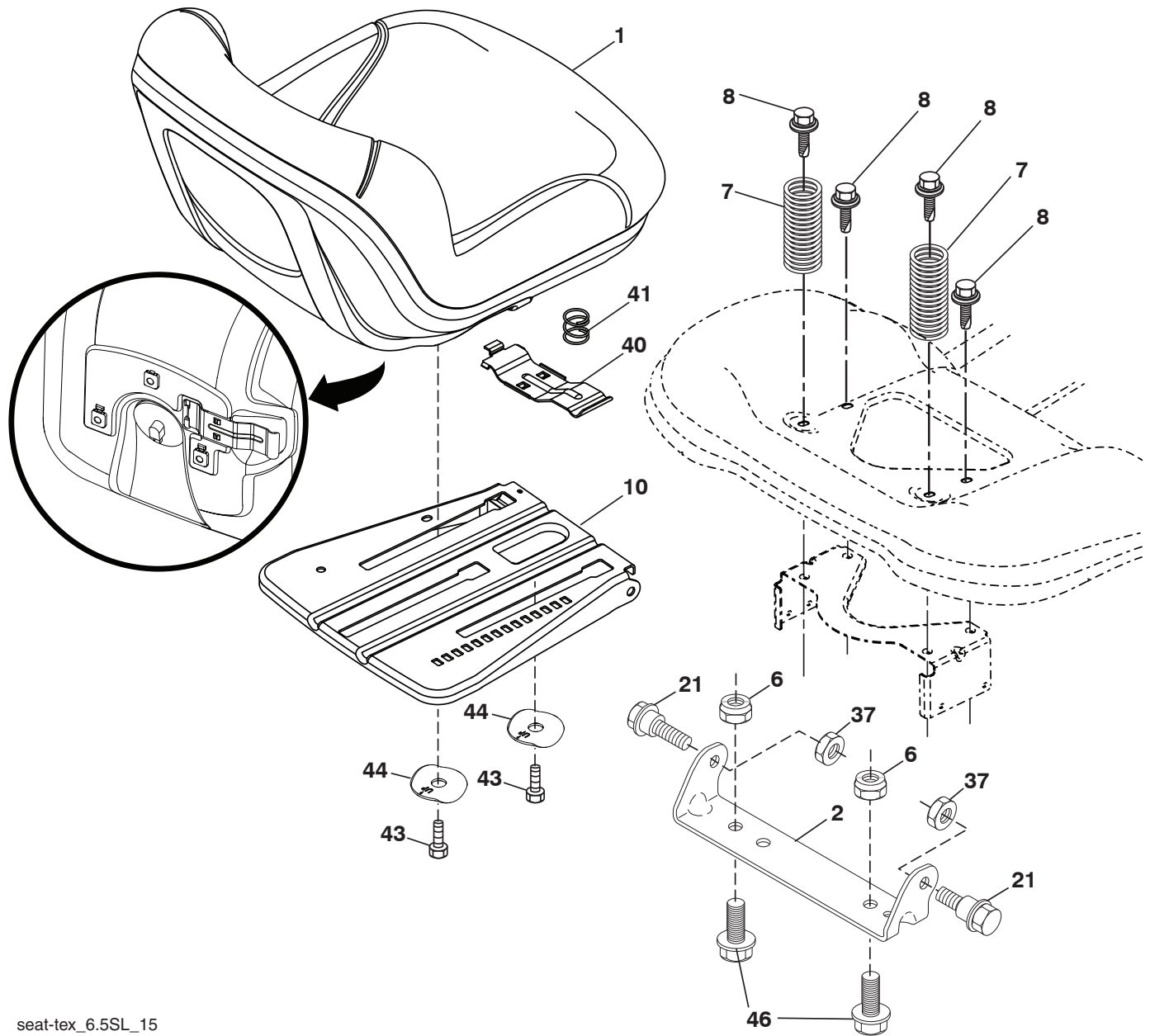

seat-tex\_6.5SL\_15

KEY NO.	PART NO.	DESCRIPTION
1	581 46 20-01	Seat
2	532 18 01-66	Bracket Pivot Fender
6	873 80 06-00	Nut, Lock w/Ins. 3/8-16 unc
7	589 48 35-01	Spring, Seat Cprsn
8	532 17 18-77	Bolt 5/16-18 unc x 3/4 w/Sems
10	587 23 20-02	Pan, Seat
21	587 90 78-01	Bolt, Shoulder 5/16-18 x 5/8
37	873 80 05-00	Nut, Lock 5/16-18 unc

KEY NO.	PART NO.	DESCRIPTION
40	532 19 76-61	Handle Slide
41	532 19 82-00	Spring Latch
43	874 76 06-12	Bolt Fin Hex 3/8-16 unc x 3/4
44	501 05 18-01	Washer Winged
46	588 09 04-01	Bolt 3/8-16 x 1, 1.25 OD

**NOTE:** All component dimensions given in U.S. inches  
1 inch = 25.4 mm

TRACTOR - - MODEL NO. M165-97T CLASSIC (96041040700), PRODUCT NO. 960 41 04-07  
MCCULLOCH ENGINE (452 CC)

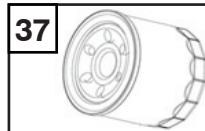
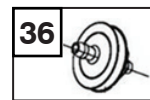
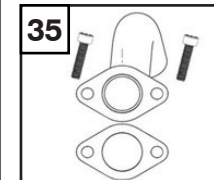
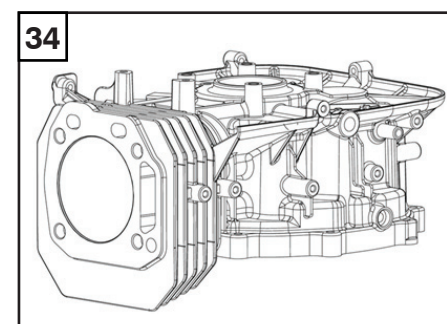
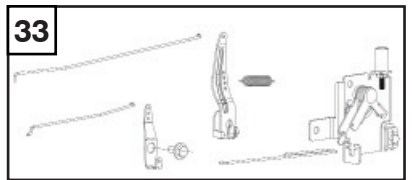
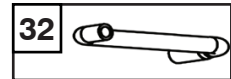
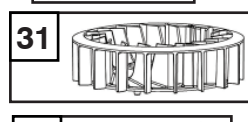
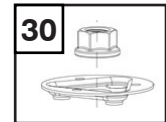
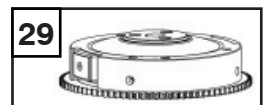
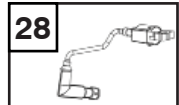
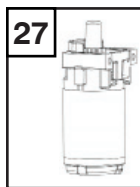
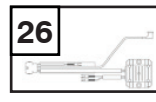
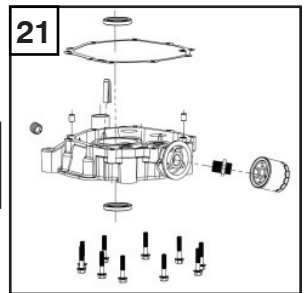
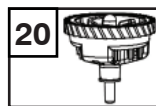
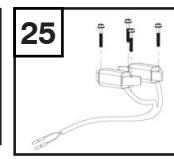
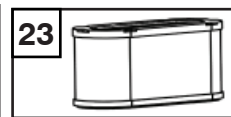
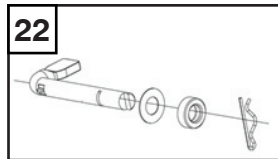
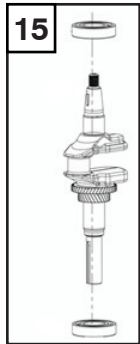
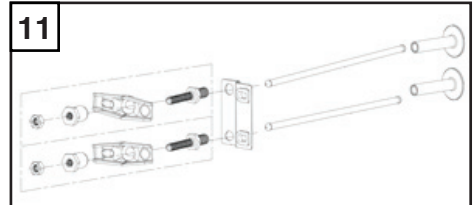
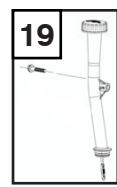
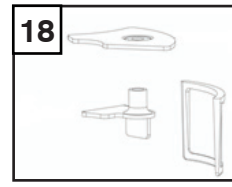
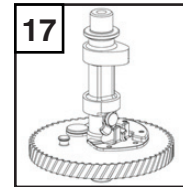
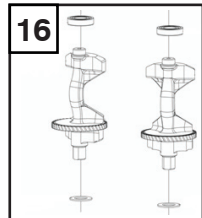
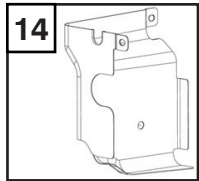
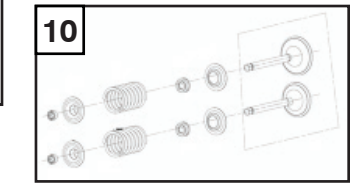
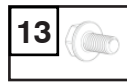
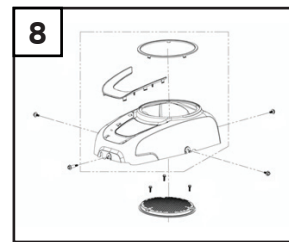
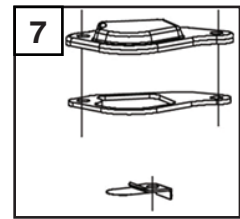
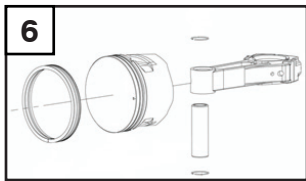
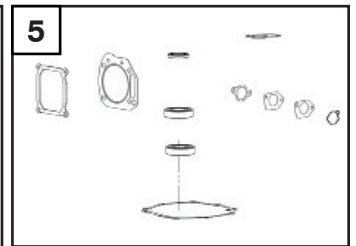
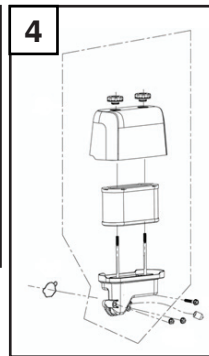
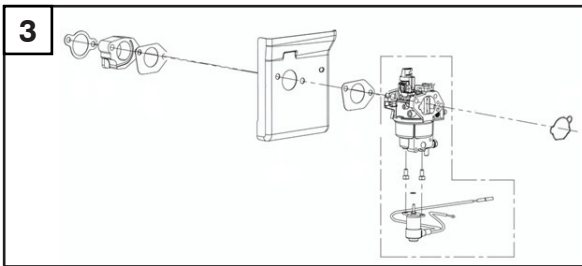
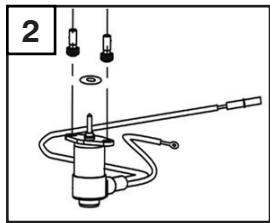
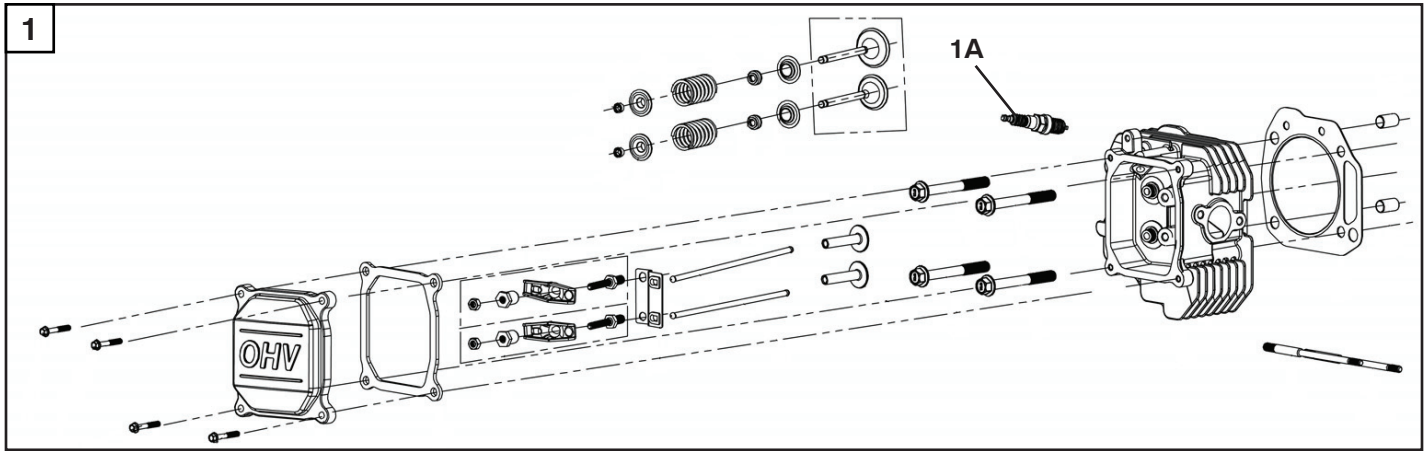

**TRACTOR - - MODEL NO. M165-97T CLASSIC (96041040700), PRODUCT NO. 960 41 04-07  
MCCULLOCH ENGINE (452 CC)**

<b>ITEM NO.</b>	<b>PART NO.</b>	<b>DESCRIPTION</b>	<b>QTY.</b>
1	590904901	CYLINDER HEAD COMP KIT	1
1A	591165501	SPARK PLUG	1
2	590905101	SOLENOID KIT	1
3	590905201	CARBURETOR KIT	1
4	590905301	AIR CLEANER KIT	1
5	590905401	GASKET AND SEAL KIT	1
6	590905501	PISTON AND RING SET, PISTON KIT	1
7	590905601	COVER COMP BREATHER AND STRAINER FUEL KIT	1
8	590905701	START COVER KIT	1
10	590971701	VALVE KIT	1
11	590971801	ROCKER ARM KIT	1
13	590971901	HEXAGON BOLT WITH FLANGE	1
14	590972101	AIR DEFLECTOR	1
15	590972201	CRANKSHAFT KIT	1
16	590972301	BALANCING SHAFT KIT	1
17	590972401	CAMSHAFT ASSY	1
18	590972501	OIL STRAINER KIT	1
19	590972601	FILL TUBE KIT	1
20	590972701	COMPONENTS OF GOVERNOR GEAR	1
21	590972801	CRANKCASE COVER KIT	1
22	590972901	SPEED REGULATING ARM KIT	1
23	590973101	AIR FILTER ELEMENT COMBINATION	1
24	590973501	PRESSING PLATE KIT	1
25	590973601	CHARGING ARMATURE KIT	1
26	590973801	VOLTAGE RECTIFIER	1
27	590974301	STARTER MOTOR KIT	1
28	590975801	COIL ASSY.,IGNNTION	1
29	590978001	FLYWHEEL COMP	1
30	590992201	STARTING DISC KIT	1
31	590992301	IMPELLER	1
32	590965901	BREATHER TUBE	1
33	590992501	THROTTLE LEVER KIT	1
34	592951101	CRANKCASE BODY KIT	1
35	592952001	EXHAUST PIPE KIT	1
36	591165801	FUEL FILTER	1
37	591165901	OIL FILTER	1

