

# OWNER'S MANUAL

## SELF-PROPELLED CHAIN DRIVE TILLER

### MODELS 2805-0400, 2805-0500 & 2805-0700

#### WARRANTY

#### ONE YEAR LIMITED WARRANTY

For one (1) year from date of purchase by the first consumer for residential use (thirty (30) days commercial use), Western International Incorporated warrants that it will replace free of charge, including labor, any original part of any Western International Incorporated product found to be defective by any authorized Service Dealer or the factory.

This warranty does not cover battery (if so equipped) or engine (these items are covered by their manufacturer's own warranty). This warranty does not cover parts that have failed due to normal wear or parts that have failed subject to misuse or abuse. Transportation of the unit or part to and from an authorized Service Dealer or the factory is the responsibility of the owner.

A step by step explanation as to what procedure should be followed for this Warranty is:

1. If a part becomes defective, contact the store where the unit was purchased for the name and address of the authorized Service Dealer nearest to you.
2. If you cannot locate an authorized Service Dealer, write Service Department of Western International Incorporated for the name and address of the authorized Service Dealer in your area or call the Service Dept. at 1-800-247-7464 (outside Iowa), 1-515-265-3461 (Iowa).
3. Return the defective product, along with proof of purchase to such authorized Service Dealer for replacement of any defective part where covered by this warranty.

There is no other express warranty. Implied warranties, including those of merchantability and fitness for a particular purpose are limited to one (1) year from date of purchase. Liability for incidental or consequential damages are excluded.

Some states do not allow limitations on how long an implied warranty lasts, so the above limitation may not apply to you. Some states do not allow the exclusion of incidental or consequential damages, so the above exclusion may not apply to you. This warranty gives you specific legal rights, and you may have other rights which vary from state to state.

Western International Incorporated

P.O. Box 377

Des Moines, Iowa 50302

#### UNIT PARTS AND SERVICE

This manual contains instructions for safety, assembly and maintenance. Read this manual carefully and completely so that you will know proper assembly, use and care of your unit. Also fill in and mail the registration card packed with the unit. For service other than covered in this manual, contact an authorized service dealer. A nationwide parts and service organization has been established to provide locally available parts and service. A list of authorized parts distributors has been included in this manual. When ordering repair parts, always give the following information: 1. The Part Name; 2. The Part Number; 3. The Quantity desired; 4. The Full (eight digit) Model Number of the unit. The model number will be found on a plate attached to the unit.



Look for this symbol.

It means - ATTENTION! BECOME ALERT! A HAZARD TO OPERATOR, BYSTANDERS, PROPERTY OR EQUIPMENT MAY EXIST.

WESTERN INTERNATIONAL INCORPORATED

P.O. BOX 377

DES MOINES, IOWA 50302

Part No. 62793

0486



## OPERATIONAL PRECAUTIONS



THESE INSTRUCTIONS ARE FOR YOUR PROTECTION. PLEASE READ THEM CAREFULLY.

### TRAINING

1. Read the Owner's Manual carefully. Be thoroughly familiar with the controls and the proper use of the equipment. Know how to stop the unit and disengage the controls quickly.
2. Never allow children to operate the equipment. Never allow adults to operate the equipment without proper instructions.
3. Keep the area of operation clear of all persons, particularly small children, and pets.

### PREPARATION

1. Thoroughly inspect the area where the equipment is to be used and remove all foreign objects.
2. Disengage all clutches and shift into neutral before starting the engine.
3. Do not operate the equipment without wearing adequate outer garments. Wear footwear which will improve footing on slippery surfaces.
4. Handle fuel with care; it is highly flammable.
  - (a) Use an approved fuel container.
  - (b) Never add fuel to a running engine or hot engine.
  - (c) Fill fuel tank outdoors with extreme care. Never fill fuel tank indoors.
  - (d) Reinstall gasoline cap securely and clean up spilled fuel before restarting.
5. Never attempt to make any adjustments while the engine is running (except where specifically recommended by manufacturer).

### OPERATION

1. Do not put hands or feet near or under rotating parts.
2. Exercise extreme caution when operating on or crossing gravel drives, walks, roads. Stay alert for hidden hazards or traffic.
3. After striking a foreign object, stop the engine. Remove the wire from the spark plug, thoroughly inspect the tiller for any damage, and repair the damage before restarting and operating the tiller.
4. Exercise caution to avoid slipping or falling.
5. If the unit should start to vibrate abnormally, stop the engine and check immediately for the cause. Vibration is generally a warning of trouble.
6. Stop the engine whenever you leave the operating position. Also disconnect spark plug wire before unclogging the tines and when making any repairs, adjustments, and inspections.
7. Take all possible precautions when leaving the machine unattended. Shift into neutral and stop the engine.
8. Before cleaning, repairing, or inspecting, shut off the engine and make certain all moving parts have stopped. Disconnect the spark plug wire, and keep the wire away from the plug to prevent accidental starting.
9. NEVER run engine indoors. Exhaust fumes contain CARBON MONOXIDE which is an ODORLESS and DEADLY POISONOUS GAS.
10. Never operate the tiller without proper guards, plates, or other safety protective devices in place.

11. Keep children and pets away.
12. Do not overload the machine capacity by attempting to till too deep at too fast a rate.
13. Never operate the machine at high transport speeds on slippery surfaces. Look behind and use care when backing.
14. Never allow bystanders near unit.
15. Never operate the tiller without good visibility or light.

### MAINTENANCE AND STORAGE

1. Check all fasteners at frequent intervals for proper tightness to be sure the equipment is in safe working condition.
2. Never store the machine with fuel in the fuel tank inside a building where ignition sources are present such as hot water and space heaters, clothes dryers, etc. Allow the engine to cool before storing in any enclosure.
3. Always refer to the Owner's Manual for important details if the tiller is to be stored for an extended period.

### CONTENTS OF SHIPPING CARTON

- 1 - 28 inch Chain Drive Rotary Tiller
- 1 - Engine Manual
- 1 - Owner's Manual
- 1 - Handle Panel
- 1 - Handle Mount Plate
- 1 - Upper Handle
- 1 - Shift Control Rod
- 1 - Right Outer Tine Assembly
- 1 - Left Outer Tine Assembly
- 1 - Bag Containing Engine Air Cleaner
- 1 - Bag of Assembly Parts Containing:
  - 1 - Small Hand Grip (shift lever)
  - 2 - Large Hand Grips (upper handle)
  - 1 - Knob (throttle control)
  - 1 - Shift Arm
  - 1 - Shift Lever
  - 1 - Spring
  - 1 - Retainer Bracket (shift rod)
  - 2 - Retainer Nuts
  - 1 - Hairpin Cotter
  - 8 - 1/4 inch Locknuts
  - 6 - 5/16 inch Locknuts
  - 1 - 5/16 inch Keps Locknuts (star washer attached)
  - 2 - 3/8 inch Locknuts
  - 2 - Formed (Curved) Washers
  - 1 - 13/32 inch Flatwasher
  - 2 - 13/64 inch Flatwashers
  - 6 - 9/32 inch Flatwashers
  - 4 - No. 10 x 1/2 inch Hex Slot Head Screws
  - 2 - No. 10 Tinnerman Nuts
  - 8 - 1/4 x 1/2 inch Hex Head Screws
  - 3 - 5/16 x 3/8 inch Hex Head Screws
  - 1 - 5/16 x 1 1/4 inch Carriage Bolt
  - 2 - 5/16 x 1 1/4 inch Hex Head Screws
  - 2 - 3/8 x 1 3/4 inch Hex Head Screws

HOW TO MEASURE SCREW SIZE  
(5/16 x 1 1/2 INCH)

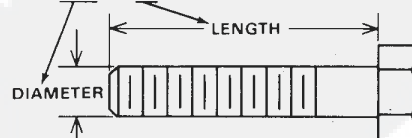

## OWNER'S INFORMATION

Record the following information about your unit so that you will be able to provide it in case of loss or theft.

MODEL NUMBER: 2805-0400, 2805-0500 or 2805-0700 (Circle number that appears on model plate)  
 PURCHASE DATE: \_\_\_ / \_\_\_ / \_\_\_ CODE NO. \_\_\_\_\_ SERIAL NO. \_\_\_\_\_  
 DEALER'S NAME AND ADDRESS \_\_\_\_\_  
 CITY \_\_\_\_\_ STATE \_\_\_\_\_ TELEPHONE \_\_\_\_\_

## ASSEMBLY

### TOOLS REQUIRED FOR ASSEMBLY

- 1 - 5/16 inch Wrench or Screwdriver
- 2 - 7/16 inch Wrenches (or adjustable wrenches)
- 2 - 1/2 inch Wrenches (1 should be socket w/extension)
- 2 - 9/16 inch Wrenches (or adjustable wrenches)
- 1 - Pair Pliers

The tiller is packed partially assembled. The handles, controls, and outer tine assemblies were left unassembled for shipping purposes. For easier assembly, the step by step instructions **must** be followed exactly. **DO NOT** begin a second step until you have completed the preceding step. Refer to the illustrations when they are called out in a step. They will help identify parts and also show assembly methods.

### ⚠ DANGER ⚠

The operation of any powered equipment can result in foreign objects being thrown into the eyes, which can result in severe eye damage. Always wear safety glasses or eye shields before assembling or operating rotary tiller.

### OUTER TINE ASSEMBLY

The two outer tine assemblies were packed loose in the carton for easier packaging of the unit. There is a right and left hand assembly and each must be correctly installed for proper operation (see figure 1). To identify the loose tine assemblies as right or left tines, check them against the other two tine assemblies that are already installed on the unit. The blades of both tine assemblies must have the sharp edge facing forward when installed properly on the unit. After determining the proper side of each tine assembly,

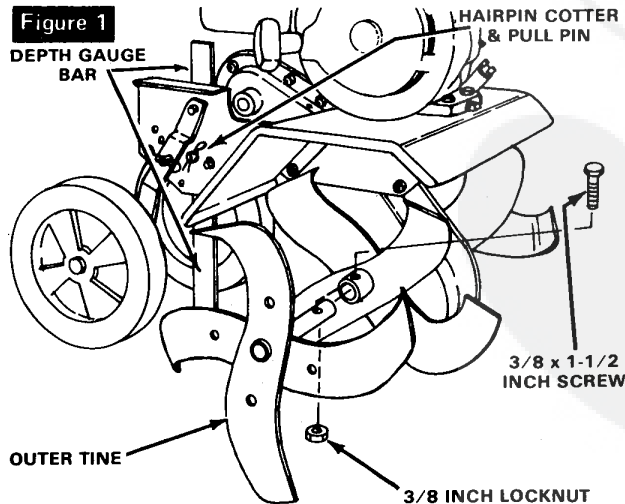

Figure 1

attach them to the exposed shaft end with two 3/8 inch x 1 1/2 inch hex head screws and 3/8 inch locknuts provided.

### HANDLE AND CONTROLS ASSEMBLY

1. Snap two retainer nuts (figure 2) into small square holes in back side of handle panel. **NOTE:** Be sure to attach retainer nuts to inside of brace across back of handle panel as shown.

2. Attach handle panel to handle mounting plate (with notch in plate forward as shown in figure 2) with six 1/4 x 1/2 inch hex head screws, six 1/4 inch flatwashers (on outside) and six 1/4 inch locknuts. These screws must be tightened securely because of leverage applied during operation of tiller.

3. Remove hairpin cotter and pull pin from depth bar gauge (figure 1) and remove gauge from unit.

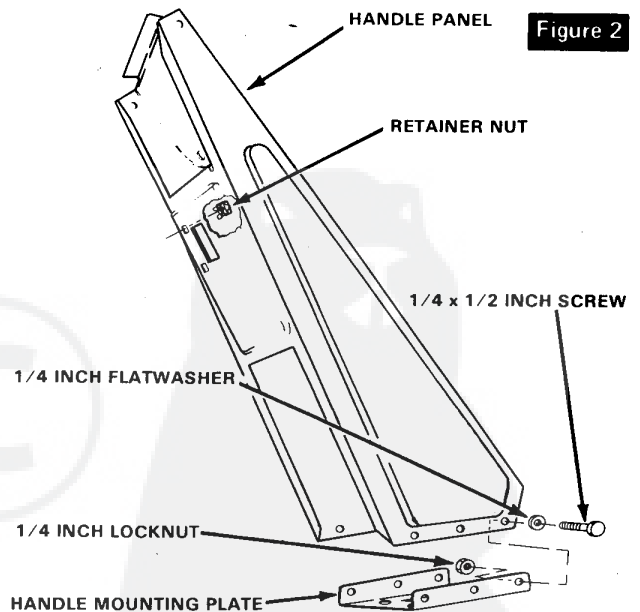

Figure 2

4. Thread throttle control (attached to engine) through front of handle panel between panel and mounting plate (in figure 3).

5. Place assembled handle panel and plate onto rear of unit. Place front left hole in mounting plate over stud in left side frame.

6. Secure handle panel to side frames with three 5/16 x 3/8 inch hex head screws and four 5/16 inch locknuts (extra locknut on stud in side frame). **NOTE:** These screws must be tightened securely.

7. Replace removed depth bar gauge.

**Figure 3**

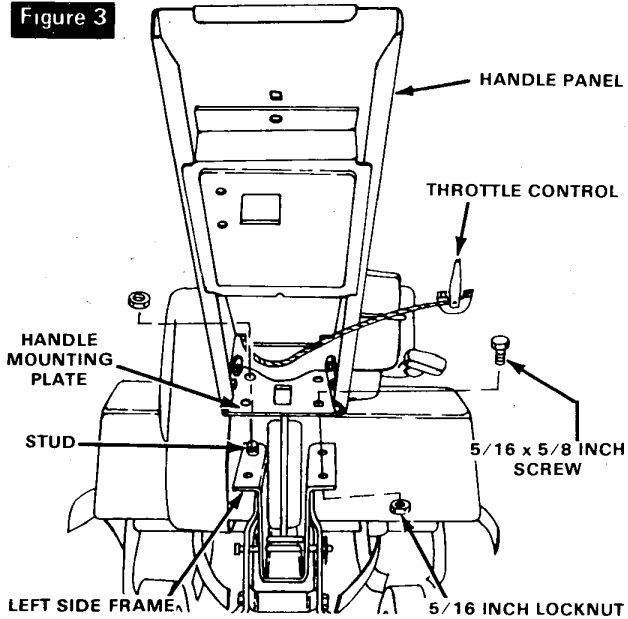

8. Place two No. 10 tinnerman nuts (figure 4) onto throttle control. **NOTE:** Be sure to place nuts onto throttle control so that flat side is up.
9. Place throttle control lever up through right slot in handle panel.
10. Attach throttle control to handle panel with two No. 10 x 1/2 inch slotted hex head screws. **NOTE:** Before tightening screws, make sure throttle lever is centered in slot so that it does not rub either side of slot.
11. Press the "T" shaped knob onto throttle lever. **NOTE:** It may be necessary to tap (lightly) knob with a plastic or rawhide hammer to make knob snap into place on lever.

**Figure 4**

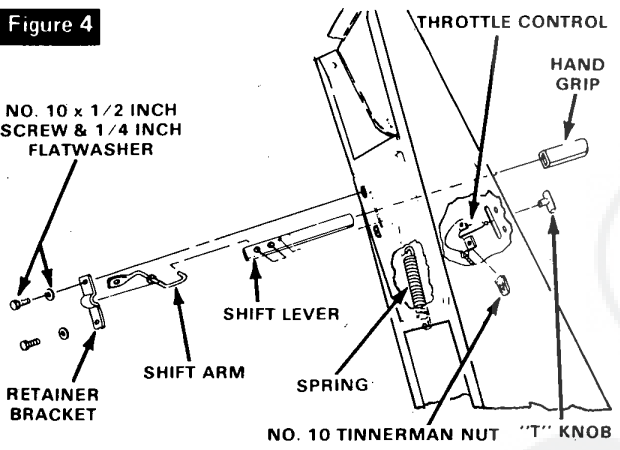

12. Place shift lever onto shift arm as shown in figure 4.
13. Push shift lever up through square hole in back of handle panel and through slot in front side of panel.
14. Attach shift arm (figure 4) to back side of handle panel with retainer bracket and two No. 10 x 1/2 inch slotted hex head screws and two 1/4 inch flatwashers and into retainer nuts installed in step 1. **NOTE:** Do not tighten these screws until shift rod has been installed.
15. Attach shift rod to shift arm as shown in figure 5 with a 13/32 inch flatwasher and a hairpin cotter.
16. Attach shift rod to clutch rod (extending from back of belt cover) with two 1/4 x 1/2 inch hex head screws and two 1/4 inch locknuts as shown in figure 5.

**Figure 5**

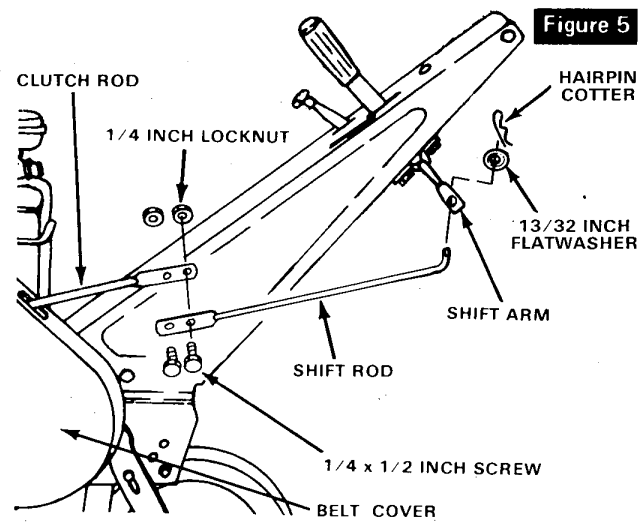

17. Place shift lever in NEUTRAL position and hold there while tightening screws in shift arm retainer bracket (screws left loose in step 4).
18. Place shift lever in FORWARD position and hook one end of spring (figure 4) into small hole in shift lever. Pull other end of spring down and hook into notch at center of brace across back of handle panel.
19. Return shift lever to NEUTRAL position and place small hand grip onto shift lever.
20. Place upper handle into top end of handle panel as shown in figure 6. **NOTE:** Handle height can be changed by turning upper handle over (angle down for low, angle up for high).
21. Attach center of upper handle with a 5/16 x 1 1/2 inch carriage bolt (round head) down through front of handle panel, through handle and through back brace on handle panel. Secure with a 5/16 inch keps (lockwasher attached) locknut.
22. Attach upper handle to both sides of handle panel with two 5/16 x 1 1/4 inch hex head screws, two formed (curved) washers and two 5/16 inch locknuts. **NOTE:** Formed washers must be installed on inside of handle as shown in figure 6.
23. Place a large hand grip onto each end of upper handle. **NOTE:** Grips may be difficult to install. Dipping grips into warm soapy water will help installation.

**Figure 6**

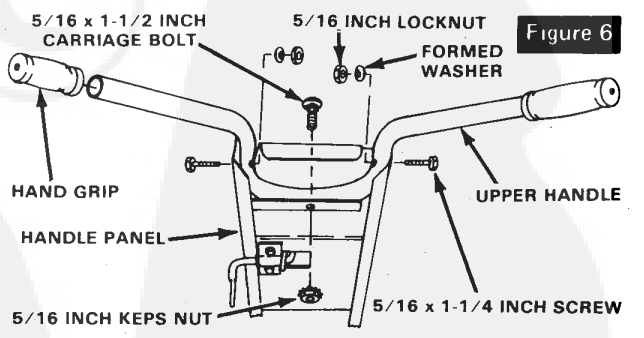

**AIR CLEANER INSTALLATION**

For packaging purposes, the engine air cleaner was removed and placed in a plastic bag. To install air cleaner (see figure 7 for proper order of parts):

1. Remove and discard paper protector from bottom end of stud.
2. Remove knob from stud.

3. Disassemble air cleaner parts.
4. Place stud into carburetor and tighten with a pair of pliers or similar tool. **NOTE:** Be sure that, **this side up**, side of plate is up or plate will interfere with throttle lever.
6. Place cartridge (large opening down) over stud and down against base plate.
7. Place cover over cartridge (flat side toward rear of engine) and secure with knob.

Figure 7

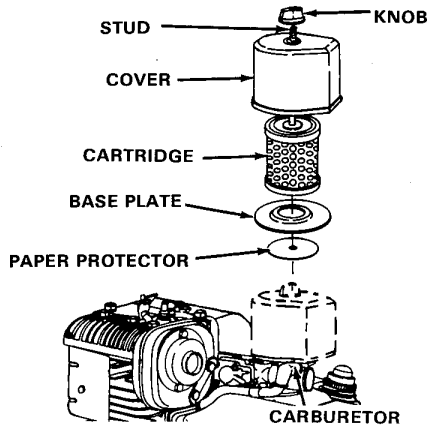

### TO CHECK SHIFT CONTROL

1. Disconnect spark plug wire and tie back if necessary to make sure wire will not contact plug.

## ⚠ DANGER ⚠

The engine on this tiller may have been test run and enough gas could have been left in carburetor to allow engine to start if spark plug wire is not disconnected.

2. Place shift lever in NEUTRAL position.
3. Pull starter handle several times to make sure tines do not rotate.
4. Place shift lever in FORWARD position and pull starter handle. Tines should rotate forward.
5. Pull shift lever to REVERSE position and hold while pulling starter handle. Tines should rotate in reverse.
6. If any of three positions are not properly reached, adjust as follows:
  - A. Loosen screws in shift arm retainer bracket (figure 4).
  - B. Slide bracket up or down slightly and retighten screws.
  - C. Repeat steps 2 through 4 to see if all three positions can be reached.
7. Replace spark plug wire onto spark plug.

### TO SERVICE ENGINE

1. Place tiller so that engine is in a level position.
2. Fill engine crankcase with oil. See **Engine Operation and Maintenance Manual** for proper procedure. Check oil before each use and add oil as needed.
3. Fill gas tank with clean, fresh, regular grade automotive gasoline. Low-lead gasoline is an acceptable substitute. **Do not use Ethyl, high octane gasoline or Gasohol.** Be certain container is clean and free from rust or foreign particles. Never use gasoline that may be stale from long periods of storage in the container.

## ⚠ DANGER ⚠

Never fill the gas tank while the engine is running or hot. Immediately wipe off any spilled gasoline before attempting to start engine.

## OPERATION

The operation of this tiller can result in foreign objects being thrown into the eyes, which can result in severe eye damage. Always wear safety glasses or eye shields while operating tiller. We recommend standard safety glasses or Wide Vision Safety Mask for over spectacles.

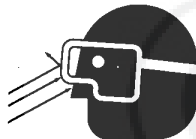

Get to know your tiller and its controls. Be sure that you (or any other operator) have read and understood the **Operational Precautions** listed on page 2 of this manual.

### OPERATING CONTROLS

Figure 8 shows the controls on this tiller. The controls and their functions are as follows:

- **Throttle Control** - The throttle control (mounted on handle panel) regulates engine speed. Throttle control also has a stop position (pulled all the way back) to stop engine.
- **Shift Lever** - The shift lever is used to start and stop or reverse the rotation of the tines. This control is also mounted on the handle panel with three positions labeled on the control: NEUTRAL, FORWARD and REVERSE.

To change the shift lever from NEUTRAL to FORWARD, pull back on the lever just enough to clear the catch on the control panel. After the catch is cleared, pull the lever to the left and push it down to the FORWARD

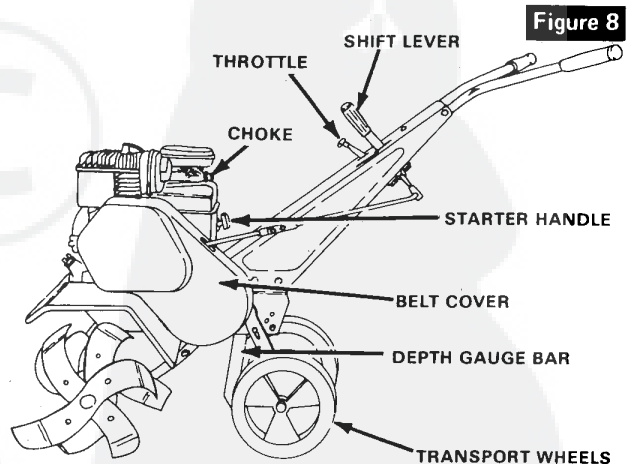

position. To engage REVERSE position, pull the clutch lever back to NEUTRAL and then pull the lever backward into REVERSE. **IMPORTANT:** The clutch control lever must be held in REVERSE position while operating the tiller.

- **Starter Handle** - This tiller is equipped with a recoil starter.

- **Depth Gauge Bar** - Is used to help maintain the selected tilling depth. It also acts as a brake to help the operator control direction and speed of the tiller. It is adjusted by removing the hair pin which frees the pull pin and moving the bar up or down to the desired depth. Replace the pull pin and lock in place with hair pin.
- **Transport Wheel Assembly** - May be raised or lowered. A similar pull pin arrangement is provided. See paragraph **To Operate Tiller** for further information.

**⚠ DANGER ⚠**

Keep hands and feet clear of tiller tines and all moving parts while starting engine.

## TO START ENGINE

Tiller was shipped with **NO OIL** in engine. **Be sure oil has been added before trying to start engine.**

1. Be certain shift lever is in NEUTRAL position.
2. **MOVE THROTTLE LEVER TO ANY POSITION BETWEEN STOP AND FAST.** **NOTE:** If engine is cold, the engine must be choked to get it started. Use the manual type push-pull choke located above the gas tank and below air cleaner. If the engine is warm, the choke may not be needed.
3. To start engine, stand towards the right rear of tiller. Place one hand on tiller handle to steady unit and grasp the recoil starter handle (figure 8) with other hand. Pull up sharply on the recoil starter but do not allow the starter rope to snap back. Let the rope rewind slowly while keeping hold of the starter handle. Repeat this procedure until engine starts.
4. When the engine starts, release the choke from full **CHOKED** position to keep engine running smoothly. Slowly move the throttle lever to the desired engine speed. If engine stalls, repeat steps 1 through 4.
5. To stop engine, place shift lever in NEUTRAL position to disengage rotating blades and move the throttle lever to the **STOP** position.

**⚠ DANGER ⚠**

Never leave the tiller unattended while the engine is running. Always disengage the clutch control to stop engine.

## TILLING TIPS

There are several important facts to know about tilling before you operate this tiller. Most important is the fact that slow top speed produces the best soil texture. It is a common fault to want to till the soil to a fine consistency. This robs the soil of its moisture holding ability. The consistency of the soil during tilling is controlled by the speed of the engine. The faster the engine is run, the finer the texture will be.

Second, the speed with which an area can be tilled depends upon the depth of cut and not on the speed of the engine. A six inch cut will take about twice as long as a 3 inch cut.

Third, tilling generally is dusty work and the air filter on the engine should be checked and cleaned more often than normal. (See the engine manual.)

The depth gauge bar located on the back of the tiller serves as a double purpose. It helps regulate the depth of the cut to a uniform level and also acts as a brake to help the operator control the speed of the tiller.

## TO OPERATE TILLER

**Read the following directions completely before operating this tiller.**

1. Place shift lever on the handle up to the NEUTRAL position. Start the engine. Be sure you are familiar with the engine and its controls before starting the engine.
2. After the engine is started, set engine speed to half speed or more. Tip tiller back on the wheels so the blades clear the ground. Push the shift lever down to FORWARD position and the blades will begin to turn. If blades do not turn, see **To Check Shift Control** paragraph in **Assembly** section of this manual.
3. Let the tiller down slowly. As the blades begin to make contact with ground, hold back on the tiller so the blades will dig and not ride forward over the ground. Hold back until the blades dig to desired depth. Let the machine till forward about 4 feet, being careful to maintain a uniform depth. Pull the shift lever back to NEUTRAL and stop the unit.
4. Remove the pin on the depth gauge bar (figure 8) and push the bar down to the bottom of the cut. Reset pin.
5. Move the shift lever to FORWARD and begin tilling operation. Keep a downward pressure on the handle to keep the depth gauge bar down in the bottom of the cut to maintain the desired depth of cut. Observe the consistency of the soil. If it is too coarse, speed up the engine. If it is too fine, slow the engine down.
6. The tiller will do a better job and operation will be easier if a slight side-to-side movement is maintained on the handle. This is especially true when making a cut next to tilled soil as the tiller will have a tendency to drift toward the loose soil.
7. We advise against tilling soil that is too dry as the soil pulverizes and produces a dust that will not hold water. Likewise, tilling soil that is too wet will produce unsatisfactory clods besides being hard on the machine.
8. Better growth will be obtained in tilled ground if a relatively small area is tilled properly and the tilled ground used soon after tilling to preserve the moisture content.
9. Some soil conditions may require that the tiller be operated with the transport wheels raised. Some people find it easier or desirable to always till with the wheels raised. To raise the wheels, remove the hairpin cotter on the pull pin and remove the pull pin from chassis. The entire wheel assembly will be free to be pulled up out of the way. Replace pin through hole in chassis where wheels will be held at desired height and replace hairpin cotter. **NOTE:** Full upright, with pull pin located through depth gauge bar, should be used for transporting tiller.

## ADJUSTMENTS

### **⚠ DANGER ⚠**

Always disconnect spark plug wire before making any adjustments to the tiller.

The drive belts on this tiller may stretch with use and require adjustment.

### FORWARD DRIVE BELT ADJUSTMENT

The forward drive belt (belt nearest engine) can be adjusted as follows:

1. Remove Belt cover (figure 8).
2. Loosen screw that attaches idler wheel to idler arm (figure 9).
3. Slide idler wheel up in slot on idler arm to tighten belt and retighten screw.
4. Replace belt cover.

### REVERSE DRIVE BELT ADJUSTMENT

The reversing drive belt (belt farthest from engine) can be adjusted as follows:

1. Remove belt cover (figure 8).

2. Loosen screw that attaches pulley cap to idler arm (figure 9).

3. Slide pulley cup up in slot on idler arm to tighten belt and retighten screw.

4. Replace belt cover.

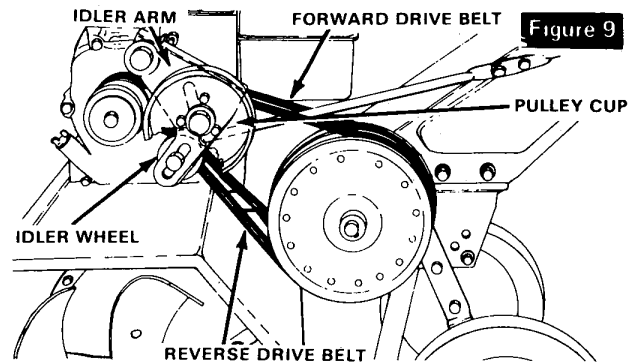

### SHIFT ROD ADJUSTMENT

To adjust shift rod see **To Check Shift Control** paragraph in **Assembly** section of this manual.

## MAINTENANCE

### **⚠ DANGER ⚠**

Always disconnect spark plug wire before adjusting, repairing or cleaning unit.

The v-belts on your tiller should be checked occasionally for signs of wear. When the belts become worn they must be replaced with an original equipment part (see **Repair Parts** section for proper parts).

### FORWARD DRIVE BELT REPLACEMENT

To replace forward drive belt (belt nearest to engine), proceed as follows:

1. Remove belt cover (figure 8).
  2. Remove screw attaching idler arm (figure 10) to engine.
  3. Roll belt off pulleys and remove belt.
  4. Install new belt onto pulley and replace idler arm.
- NOTE:** Be sure that idler wheel is positioned below new belt.
5. Replace belt cover.

### REVERSE DRIVE BELT REPLACEMENT

To replace reversing drive belt (belt farthest from engine), proceed as follows:

1. Remove belt cover (figure 8).
2. Remove screw that attaches pulley cap (figure 10) to idler arm and remove cap.
3. Remove old belt and install new belt and replace pulley cup.
4. Replace belt cover.

### REVERSE DRIVE DISC REPLACEMENT

When reversing drive disc (located at outside end of engine shaft) becomes worn or needs replacement, it must be replaced with an original equipment part. See **Repair Parts** section of this manual for proper parts. **To replace disc:**

1. Remove belt cover (figure 8).
2. Remove screw from end of engine shaft.
3. Remove old disc and replace with new part.
4. Replace screw in engine shaft and replace belt cover.

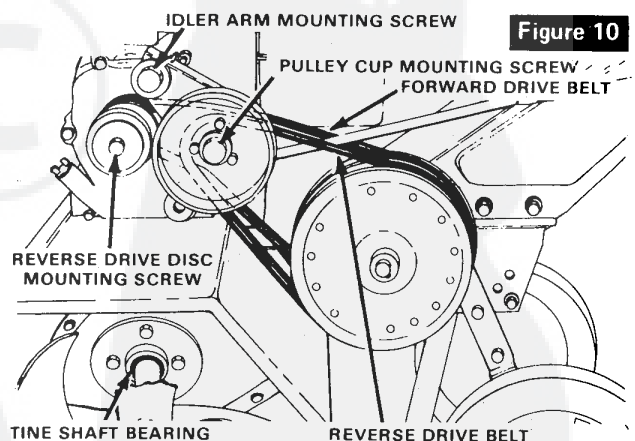

## GENERAL CARE AND LUBRICATION

The engine on your tiller should be lubricated and cared for as outlined in your engine manual. Pay special attention to cleaning the air filter.

Once each season or every 20 hours of operation apply a few drops of oil (same oil as used in crankcase) on the following:

1. Each end of idler wheel (figure 9) mounting screw.
2. Idler arm mounting screw (figure 10).
3. Pulley cap mounting screw (figure 10).
4. Remove top screw from tine shaft bearing (figure 9) on each side and squirt a few drops of oil through hole. Replace and tighten screw securely.

Longer tiller life will be experienced if your tiller engine is cared for properly and oil level checked before each use and maintained at proper intervals.

Keep all tine assembly mounting screws tight to prevent excessive wear and keep the tines sharp for best tilling results.

## STORAGE

The tiller should be immediately prepared for storage at the end of the season or if the tiller is to be un-used for 30 days or more.

### **⚠ DANGER ⚠**

**Never store engine with fuel in the tank indoors or in enclosed, poorly ventilated enclosures, where fuel fumes may reach an open flame, spark or pilot light as on a furnace, water heater, clothes dryer, etc.**

**Handle gasoline carefully. It is highly flammable and careless use could result in serious fire damage to your person and/or property.**

## ENGINE STORAGE

Gasoline, if permitted to stand un-used for extended periods (30 days or more), may develop gummy deposits which can adversely affect the engine carburetor and cause engine malfunction. To avoid this condition, proceed as follows:

1. Prior to shut down for 30 days or more, and for seasonal storage, drain gas tank if possible.

2. Run engine until fuel tank is completely empty and engine stops due to lack of fuel.

3. Remove spark plug and pour one (1) ounce of engine oil through spark plug hole into cylinder. Crank engine several times to distribute oil. Replace spark plug.

## TILLER STORAGE

1. Clean the tiller thoroughly; remove all debris and wipe the tiller dry.

2. Inspect the tiller for worn or damaged parts; tighten all loose hardware.

3. Store the tiller in a protected area and cover the tiller for additional protection.

4. Store tiller in wheel down, operating position. If tiller is stored in any other position, oil from crankcase could enter cylinder head, causing a service problem.

A yearly checkup or tuneup by a qualified repairman is a good way of insuring that your tiller will provide maximum performance for the next season.



SEE, CALL OR WRITE ONE OF THE FOLLOWING DISTRIBUTORS FOR PARTS FOR: HOMKO - LAWN SCOUT - AMF - TURFMASTER - DYNAMARK - OR ANY OTHER WESTERN INTERNATIONAL INCORPORATED PRODUCT.

#### ALABAMA

**Automotive Elect. Service**, 415 Meridian St., Huntsville, AL 35801, (205) 539-2131, AL WATS 800-536-3394 \*b,c,f,g,h  
**Warlick-Miller A/C Eng.**, 630 N. 20th St., Bessemer, AL 35020, (205) 424-8288, AL WATS 800-292-8123  
 MS WATS 800-292-4494 \*b,c,f,g,h

#### CALIFORNIA

**Billiou's**, 75 No. D, Porterville, CA 93257, (209) 784-4102 \*b,c,f,g,h  
**The Lawn Mower Shop**, 1340 El Camino Real, San Carlos, CA 94070, (415) 593-4716 \*a,d,f,g

#### COLORADO

**Spitzer Ind. Prod. Co.**, 6601 N. Washington, Thornton, CO 80229, (303) 287-3414 \*b,d,h

#### FLORIDA

**G.L.O. Products Inc.**, 13201 Belcher Rd. S., Largo, FL 33543, (813) 530-9723 \*a,c,h

**Radco Distributors Inc.** 4909 Victor St., Box 5459, Jacksonville, FL 322070459, (904) 733-7957 \*a,c,f,g,h

#### ILLINOIS

**Cox Tire & Battery**, 603 N. Market, Marion, IL 62959, (618) 993-2607 IL WATS 800-642-4351 \*a,c,f,g,h  
**Garmoe Distr. Inc.**, 2620 N. Mannheim Road, Franklin Park, IL 60131, (312) 455-3588 \*a,c,f,g,h  
**Small Engine Parts**, 3515 Auburn St., Rockford, IL 61103, (815) 964-1754 \*b,c,f,g,h

#### INDIANA

**Thompson Sales & Service**, 2400 W. Ridge Road, Gary, IN 46408, (219) 980-3282 \*a,b,c,f,g,h

#### IOWA

**Bruce Engine**, 1829 N.W. 86th, Des Moines, IA 50322, (515) 278-5151 \*a,c,f,g,h

#### KANSAS

**Colladay Hdwe. Co.**, 201 N. Plum, Box 766, Hutchinson, KS 67501, (316) 663-4477 \*a,c

#### KENTUCKY

**Auto-Electric Inc.**, 715 W. Hwy 80, Box 671, Somerset, KY 42501, (606) 679-1171 \*c,f,g,h

**Cayce Mill Supply Co.**, 1st & Douglas St., Hopkinsville, KY 42240, (502) 886-3335 \*f,g,i

**Ellingsworth Auto Electric**, 1003-08 E. Broadway, Louisville, KY 40204 (Serving Southern Indiana), (502) 585-5055, KY WATS (800) 722-5061 \*b,c,f,g,h

#### LOUISIANA

**United Engine Service, Inc.**, 11923 Cloverland Ave., Baton Rouge, LA 70809, (504) 291-2622 \*a,d,f,g,h

#### MARYLAND

**Center Supply Co.**, 6867 New Hampshire Ave., Takoma Park, MD 20912, (301) 270-1690 \*b,c,f,g,h

**Kunkel Service Co.**, 6252 Frankford Ave., Baltimore, MD 21206, (301) 377-4008, MD WATS 800-492-8886 \*b,c,f,g,h

#### MASSACHUSETTS

**Morton B. Collins Co.**, 300 Birnie Ave., Box 70058, Springfield, MA 01107, (413) 732-7449 \*a,c,g,h

**Crandall-Hicks Co.**, 250 Eliot St., Ashland, MA 01721, (617) 881-6122 \*a,d

#### MICHIGAN

**Air Cooled Engine Div.**, 615 First St., Menominee, MI 49858, (906) 863-8011, MI WATS (906 area only) 800-562-4825 \*a,c,f,g,h

**Heat Engineering Inc.**, 7700 Southfield Road, Detroit, MI 48228, (313) 271-7550 \*a,c,f,g,h

**Lorenz Service Co.**, 2500 S. Pennsylvania Ave., Lansing, MI 48910, (517) 484-1361 \*b,c,f,g,h

#### MINNESOTA

**Northern Automotive Co.**, 1401 W. Broadway, Minneapolis, MN 55411, (612) 522-6656 \*a,c,f,g,h

**MISSISSIPPI** see Bessemer, Alabama

#### MISSOURI

**Gunther's Service & Supply**, 7320 Wornall Road, Kansas City, MO 64114, (816) 523-1952 \*a,f,g,h

**Wilson Engine & Parts Inc.**, 4159 Shoreline Drive., Jct. I-70 & 270, Earth City, MO 63045, (314) 739-1313, MO WATS 800-392-4063, WATS (outside MO only) 800-367-2787 \*a,b,d,f,g,h

#### NEW JERSEY

**Power Distributors, Inc.**, 102 Mayfield Ave., Edison, NJ 08837, (201) 225-4922 \*i

#### NEW YORK

**Loegler & Ladd Inc.**, 3950 Broadway, Box 214, Buffalo, NY 14225, (716) 684-0600 \*a,c

**Stiefvater Distr. Inc.**, Clinton Road, Route 12B, New Hartford, NY 13413, (315) 853-5581 \*a,c,f,g,h

#### NORTH CAROLINA

**Carswell Distr. Co.**, 3750 N. Liberty St., Box 4193, Winston-Salem, NC 27105, (919) 767-7700 \*g,i

**Dixie Sales Co., Inc.**, 335 N. Green, Box 1408, Greensboro, NC 27402, (919) 274-0490, NC WATS 800-632-1276 \*b,c,f,g,h

#### OHIO

**American Power Distr.**, 2430 Tremainsville Rd., Box 8515, Toledo, OH 43613, (419) 475-7261 \*f,g,h

**Small Engine Distr.**, 5250 N. Dixie, Box 1481, Dayton, OH 45414, (513) 278-8241 \*b,f,g,h

#### OKLAHOMA

**Albro's**, 2921 W. Hefner Rd., Oklahoma City, OK 73120, (405) 751-1711 \*a,c,f,g,h

#### PENNSYLVANIA

**Bluemont Co.**, 11101 Frankstown Road, Pittsburg, PA 15235, (412) 242-2522 \*a,b,c,f,g,h

**Scranton Auto Ignition**, 1133 Wyoming Ave., Scranton, PA 18509, (717) 342-8133 \*b,c,f,g,h

#### SOUTH CAROLINA

**Magneto & Elect. Service**, 103 Assembly St., Columbia, SC 29201, (803) 771-4044, SC WATS 800-922-1118 \*a,c,f,g,h

#### TENNESSEE

**American Sales & Serv.**, 3035 Bellbrook Dr., Memphis, TN 38116, (901) 332-2210 \*a,d,f,g,h

**Chilton A/C Engines**, 319 4th Ave. S., Box 15806, Nashville, TN 37201, (615) 254-1634 \*b,c,f,g,h

**Ace Distr., Inc.**, 2103 E. Magnolia Ave., Box 3587, Knoxville, TN 37917, (615) 524-5359, TN WATS 800-332-9904 \*a,c,f,g,h

#### TEXAS

**Marr Bros. Inc.**, 423 E. Jefferson, Dallas, TX 75203, (214) 948-7387 \*a,c,f,g,h

**Midland Small Engine Sales**, 106 Carlton, Box 4215, Midland, TX 79704, (915) 682-1409 \*b,f,g,h

#### VIRGINIA

**Norva Small Engines**, 8120 E. Wellington Rd., Manassas, VA 22110, (703) 369-3387 \*a,c,f,g,h

**RBI Corporation**, 101 Cedar Ridge Rd., Lakeridge Park, Ashland, VA 23005, (804) 798-1535 \*a,c,f,g,h

#### WASHINGTON

**Pacific A/C Engine Inc.**, 4030 1st Ave. S., Box 84783, Terminal Annex, Seattle, WA 98124, (206) 682-4677 \*a,c,f,g,h

#### WEST VIRGINIA

**Interstate Radiator**, 1611 4th Ave., Charleston, WV 25312, (304) 345-1724 \*a,d,f,g,h

#### WISCONSIN

**Reliable Hdwe.**, 8010 N. 76th St., Milwaukee, WI 53223, (414) 355-2900 \*b,c,f,g,h

**Wiggert Brothers**, 3rd & Jay, Box 1267, La Crosse, WI 54601, (608) 784-4790 \*a,b,c,f,g,h

#### CANADA

**Suntester Equipment Ltd.**, 5466 Timberlea Blvd., Mississauga, Ontario, Canada L4W 2T7, (416) 624-6200 \*g,i

**Yetman's Ltd.**, 949 Jarvis Ave., Winnipeg, Manitoba, Canada R2X 0A1, (204) 586-8046, WATS (Manitoba & Sask.) 800-665-8623 \*b,c,f,g

Revised 1/20/86

#### (\*) General Information Codes:

- (a) Advance Payment Preferred
- (b) Accepts Credit Cards
- (c) C.O.D. okay
- (d) No. C.O.D.
- (e) C.O.D. only
- (f) Briggs & Stratton dealer or distributor
- (g) Tecumseh/Peerless dealer or distr.
- (h) Foote dealer or distributor
- (i) Dealer sales only, contact for closest dealer.

# REPAIR PARTS

SELF-PROPELLED TILLER MODELS 2805-0400, 2805-0500 & 2805-0700

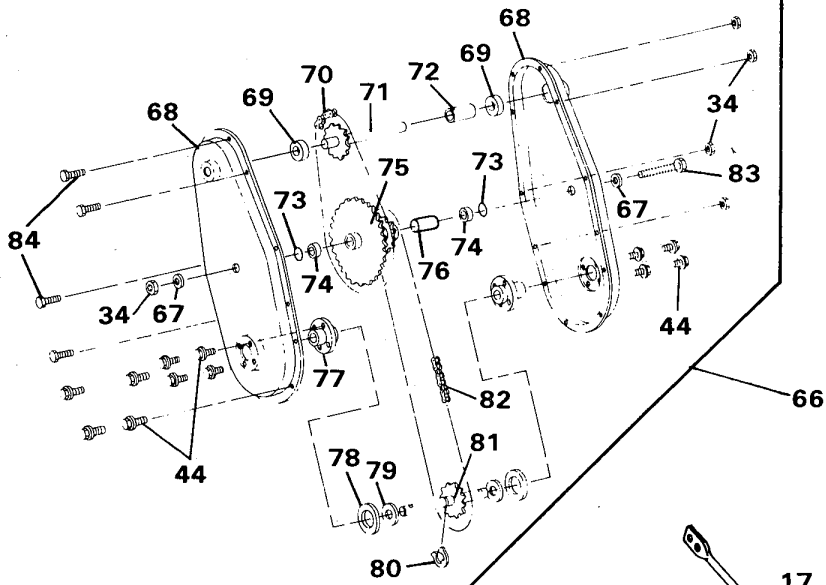

**NOTE: ALWAYS USE ORIGINAL EQUIPMENT PARTS.** Use of service/replacement parts other than original equipment parts may void your warranty.

ALL UNNUMBERED ITEMS ARE INTERCHANGEABLE WITH OPPOSITE SIDE

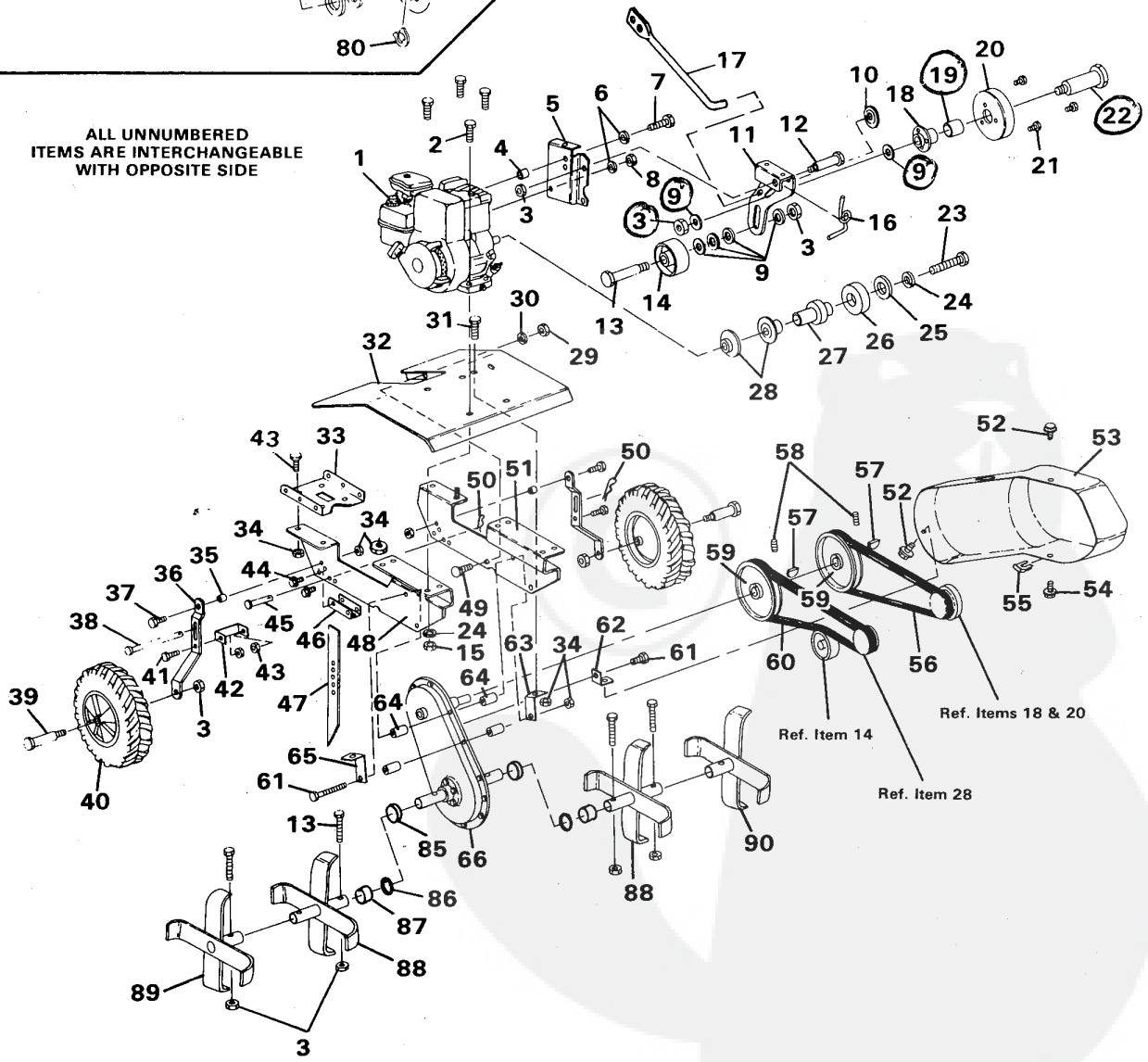

## SELF-PROPELLED TILLER MODELS 2805-0400, 2805-0500 & 2805-0700

ALWAYS GIVE THE FOLLOWING INFORMATION WHEN ORDERING REPAIR PARTS:

1. The PART NUMBER; 2. The PART NAME; 3. QUANTITY DESIRED; 4. The MODEL NUMBER (As shown on Model Plate)

SEND PART ORDERS AS PER INSTRUCTIONS ON THE FRONT PAGE

YOUR UNIT IS RIGHT HAND (RH) OR LEFT HAND (LH) AS YOU STAND BEHIND IT.

DO NOT USE KEY NUMBERS WHEN ORDERING REPAIR PARTS, ALWAYS USE PART NUMBERS.

All replacement parts will be supplied in current production colors or in a neutral color.

A handling fee is applicable to small parts orders.

Key No.	Part No.	Description
1	Engine	§See footnote below
2	122040	*Screw, Hex Hd, 5/16-18 x 1½ In.
3	9413534	Locknut, ¾-16 Thd
4	51461	Spacer
5	51164	Bracket, Mounting
6	120380	*Washer, Split, ¼ In.
7	180042	Screw, Hex Hd, ¼-20 x 1¾ In.
8	120375	*Nut, Hex, ¼-20 Thd
9	446363	*Washer, ¾ In.
10	51186	Pushnut, ¾ In.
11	51160	Idler Arm
12	51188	Shoulder Bolt
13	122168	*Screw, Hex Hd, ¾-16 x 1¾ In.
14	48924	Idler Wheel
15	120376	*Nut, Hex 5/16-18 Thd
16	51166	Belt Guide
17	51161	Rod, Clutch
18	51156	Pulley Half
19	51157	Bearing
20	51158	Cup, Pulley
21	35258	Screw, Taptite, No. 10-24 x ¾ In.
22	51189	Shoulder Bolt
23	123785	*Screw, Hex Hd, 5/16-24 x 1½ In.
24	120638	*Washer, Split, 5/16 In.
25	51143	Washer, 11/32 In.
26	51145	Disc, Reverse Drive
27	51144	Hub
28	51142	Pulley Half
29	9424215	Locknut, ¼-20 Thd
30	120392	*Washer, 9/32 In.
31	120228	*Screw, Hex Hd, 5/16-18 x ⅝ In.
32	51171	Tine Shield
33	51159	Plate, Handle Mount
34	9413447	Locknut, 5/16-18 Thd
35	51375	Spacer
36	51162	Arm, Wheel
37	122007	*Screw, Hex Hd, 5/16-18 x ¾ In.
38	51148	*Pin
39	27821	Shoulder Bolt
40	50031	Wheel & Tire Assembly, Plastic
41	122126	*Screw, Hex Hd, ¾-16 x ⅞ In.
42	51174	Brace
43	180072	*Screw, hex Hd, 5/16-18 x ⅝ In.
44	35497	Screw, Taptite, 5/16-18 x ½ In.
45	51149	Pin
46	51172	Channel

Key No.	Part No.	Description
47	51163	Depth Gauge Bar
48	51176	Frame, R.H.
49	9417711	*Carriage Bolt, ¼-20 x ½ In.
50	8260	Hairpin Cotter, 3/32 x 1⅞ In.
51	51697	Frame, L.H.
52	35144	Screw, Taptite, No. 10-24 x ⅝ In.
53	52598	Belt Cover
54	9426217	*Screw, Taptite, No. 10-16 x ½ In.
55	51194	Speed Nut, "U" Type
56	50877	V-Belt
57	24276	Key, Hi-Pro No. 506
58	998503	Set Screw, 5/16-18 x 5/16 In.
59	51170	Pulley, 7½ In.
60	50876	V-Belt
61	122089	*Screw, Hex Hd, 5/16-18 x 3 In.
62	51173	Bracket
63	51370	Strap, L.H.
64	51165	Spacer
65	51371	Strap, R.H.
66	51107	Chain Case Assembly
67	120393	*Washer, 11/32 In.
68	51108	Case, Chain
69	20257	Bearing
70	50511	Chain, No. 35
71	53265	Shaft & Sprocket Assembly
72	51120	Spacer, Long
73	51121	"O" Ring
74	51114	Bearing
75	51109	Hub, Sprockets & Bearing Assembly
76	51127	Spacer
77	51123	Bearing, Flange
78	51126	Washer, Felt
79	51579	Washer
80	51122	Retaining Ring
81	51115	Shaft & Sprocket Assembly
82	51125	Chain, No. 40
83	180091	Screw, Hex Hd, 5/16-18 x 2½ In.
84	120834	*Screw, Hex Hd, 5/16-18 x ½ In.
85	51155	Retainer
86	51153	"O" Ring
87	51154	Seal
88	51169	Inner Tine
89	51168	Outer Tine, R.H.
90	51167	Outer Tine, L.H.
91	62793	Owner's Manual (Not Illust.)

\*Standard Hardware Items - May Be Purchased Locally.

§Contact Engine Manufacturer's authorized service dealer (See Engine Manual) for parts and warranty.

# SELF-PROPELLED TILLER MODELS 2805-0400, 2805-0500 & 2805-0700

ALL UNNUMBERED  
ITEMS ARE INTERCHANGEABLE  
WITH OPPOSITE SIDE

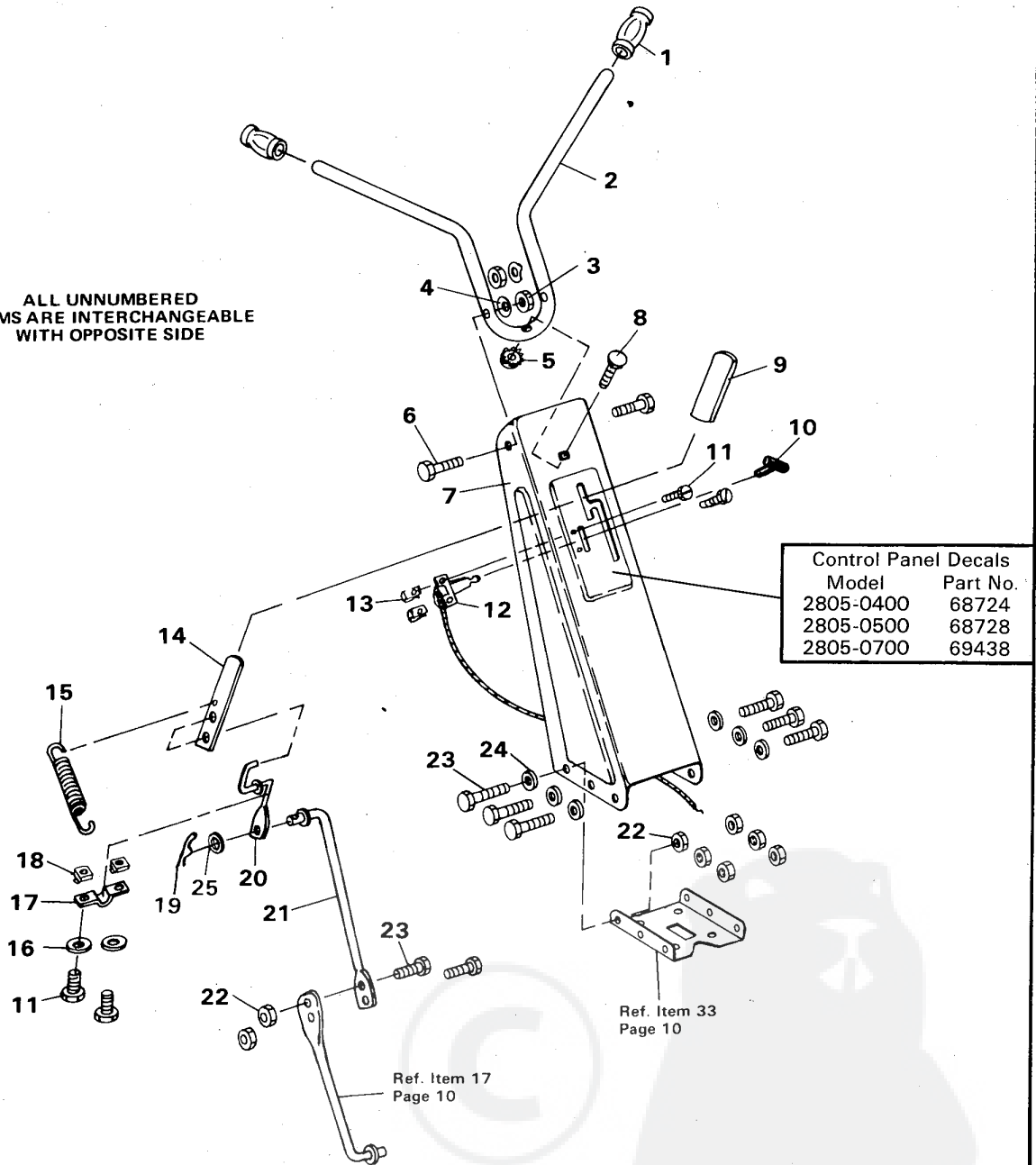

Key No.	Part No.	Description	Key No.	Part No.	Description
1	49938	Grip, Hand	13	49889	Nut, Tinnerman, No. 10-24
2	51184	Handle, Upper	14	51147	Lever, Shift
3	9413447	Locknut, 5/16-18 Thd	15	51150	Spring
4	8728	Formed Washer	16	9417373	*Washer, 13/64 In.
5	271184	Nut, Keps, 5/16-18 Thd.	17	51175	Retainer Bracket, Shift Arm
6	122027	*Screw, Hex Hd, 5/16-18 x 1 1/4 In.	18	51187	Nut, Retainer, No. 10-24 Thd
7	51139	Handle Panel Assembly	19	8260	Hairpin Cotter, 3/32 x 1 1/8 In.
8	120230	*Carriage Bolt, 5/16-18 x 1 1/4 In.	20	51146	Arm, Shift Lever
9	2540	Grip, Hand	21	56350	Rod, Shift
10	39486	Knob, Throttle Control	22	9424215	Locknut, 1/4-20 Thd
11	35291	Screw, Hex Slotted Hd, No. 10-24 x 1/2 In.	23	180016	Screw, Hex Hd, 1/4-20 x 1/2 In.
12	51185	Throttle Control Assembly	24	120392	*Flatwasher, 9/32 In.
			25	120394	*Flatwasher, 13/32 In.

\*Standard Hardware Items - May Be Purchased Locally.